

3 YEARS OPERATION & MAINTENANCE OF DGPS STATIONS FOR ROUND THE CLOCK SERVICE INCLUDING SECURITY TO THE CAMPUS

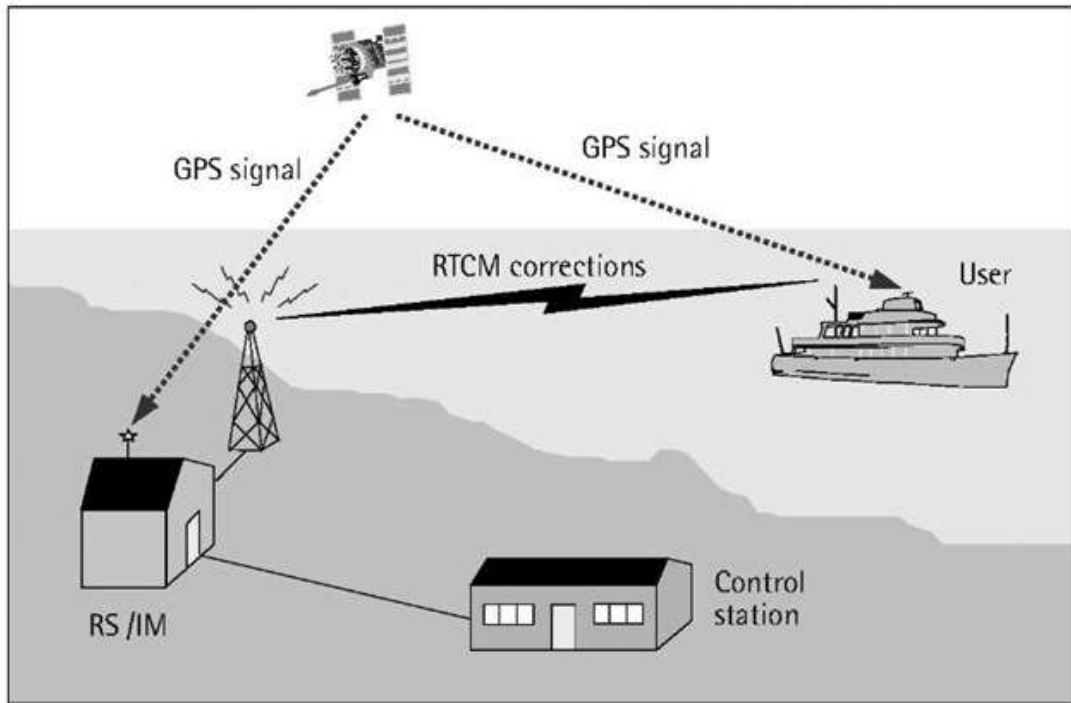

Tender Document
Tender No. IWAI/Hy/2(10)1/O&M/2014-15
August 2014



INLAND WATERWAYS AUTHORITY OF INDIA,
A-13, Sector-1, NOIDA-201 301

No. IWAI/Hy/2(10)1/O&M/2014-15

Date:

To

Sub: Tender document for Operation and Maintenance for round the clock service including security to DGPS station-reg.

Sir

The Inland Waterways Authority of India, Noida invites bid from Indian firm for providing manning service for operation and maintenance of DGPS stations at 6 different locations in National Waterway-1 and 2 for 24x7 services including security facility to the campus for a period of 3 years. The online bid and hard copy of completed bids are to be received in the office of the Hydrographic Chief, IWAI, A-13, Sector-1, Noida not later than 1500 Hours on or before [21st November 2014](#)

Yours faithfully

(Cdr.P.K.Srivastava)
Hydrographic Chief

Encl: as above.

CONTENTS

(e-Tender for Operation and Maintenance of DGPS stations round the clock service including security to the Campus)

SI No	DESCRIPTION	PAGE
1	Notice Inviting Tender	4
2	Instructions To The Tenderer	6
3	Details To Accompany Technical Bid	17
4	General Conditions Of Contract	18
5	Special Terms And Conditions Of Contract	29
6	Tender Form	31
7	Agreement Form	33
8	Performance Guarantee Form	35
9	Warranty Form	37
10	Manpower Specific Requirements.	38
11	Commercial Bid	45
Annexure-1	Questionnaire	47
Annexure-2	DGPS Station Instrument Details	49

TOTAL 52 (fifty two) PAGES

NIT FOR PUBLICATION IN NEWSPAPER



**INLAND WATERWAYS AUTHORITY OF INDIA,
A-13, Sector-1, NOIDA-201 301**

**Tender No.
IWAI/Hy/2(10)1/O&M/2014-15**

**e-Tender for Operation and
Maintenance of 6 DGPS stations in
NW-1 & NW-2**

Online bids are invited from reputed & experienced contractor/agency for operation & maintenance of DGPS stations for round the clock service including security to the campus. The details of NIT: - Tender document cost: Rs. 1,000/- Date of download of Tenders is 28.10.2014 to 20.11.2014 . Pre-bid meeting 05.11.2014 at 1130 hrs. Last date of online submission of e-tender: 21.11.2014 up to 1500 hrs. Date of opening: 21.11.2014 at 1530 hrs.

- **Detailed eligibility criteria and tender document along with Instruction to the Bidders can be seen at IWAI's website:**
www.iwai.nic.in &
<https://eprocure.gov.in/eprocure/app>,
- **However, online submission will be only through**
<https://eprocure.gov.in/eprocure/app>

HYDROGRAPHIC CHIEF

NOTICE INVITING TENDER
Tender No IWAI/Hy/2(10)1/O&M/2014-15

Bids in two sealed cover system (cover I-Technical bid and cover II- Financial bid) are invited from the interested and eligible tenderers to provide Overall maintenance, operation and security of DGPS Reference Stations (round the clock) for 3 years which is extendable further for another one year on the same terms and conditions, if needed for following locations:-

Schedule	Location	Period (w.e.f)	EMD
Schedule-A :	Swaroopganj (W Bengal)	February 2015	Rs.2.58 Lakhs
National	Bhagalpur (Bihar)	October 2014	
Waterway-1	Patna (Bihar)	February 2015	
Schedule-B :	Jogighoppa (Assam)	October 2014	Rs.3.02 Lakhs
National	Silghat (Assam)	May 2015	
Waterway-2	Dibrugarh (Assam)	October 2014	

Terms and Conditions:

1. Interested bidders may obtain non-transferable tender document by submitting non-refundable Demand draft for Rs. 1000/- (Rupees one thousand only) drawn from any Nationalized / schedule bank in favour of “Inland Waterways Authority of India Fund” payable at Noida/New Delhi.
2. Tender document will be available for sale w.e.f. 28.10.2014 to 20.11.2014. during working hours from the office of the Hydrographic Chief.
3. The tender document can also be downloaded from the website www.iwai.nic.in Detailed information and instructions to the bidders are available in the tender document. Those who are using downloaded tender document from the website may submit the cost of tender document in the form of separate DD along with technical bid, while submitting the bid.
4. A signed declaration stating that no alteration has been made in any form in the downloaded tender document is to be enclosed with the tender by the bidder for downloaded tenders.
5. Pre-bid meeting will be held on 05.11.2014 at 1130 hrs. at IWAI, Noida.
6. The completed bids as per terms and conditions mentioned in the tender document should be submitted on the above address latest by 1500 hrs on 21.11.2014. and shall be opened on the same day at 1530 hours.
7. The Hard Copy of original instruments in respect of cost of tender document, earnest money, and other documents in original as asked in this tender document must be delivered to the office of Hydrographic Chief on or before bid closing or opening date/time as mentioned in critical date sheet. Bidder shall likely to be liable for legal action for non-submission of original payment instrument like DD, etc., against the submitted bid. The Demand Draft attached/submitted for tender fee shall be non refundable.
8. The bidders may quote for any or all schedules.
9. IWAI reserves the right to accept or reject any or all bids without assigning any reasons and no correspondence shall be entertained in this regard.
10. Other terms and conditions are as per tender document.

Hydrographic Chief
I.W.A.I.

2. INSTRUCTIONS TO THE TENDERER

1. Inland Waterways Authority of India herein after referred to as “AUTHORITY” wishes to receive sealed tenders for “operation and Maintenance of DGPS Stations in NW-1 & NW-2”, which herein after referred as “service”. The prime objective of the work under this contract consists of providing prompt and efficient 24x7 operation and maintenance of Differential Global Positioning Systems reference station established at 6 locations for transmitting Position correction to GPS receivers fitted on board the various vessels which ply in the National Waterway -1 and 2.
2. **“TENDER DOCUMENT”**: Tender procedure and contract terms are prescribed in the tender documents. In addition to the invitation for tender, the tender documents include the following:-
 - (a) Notice Inviting Tender
 - (b) Instructions To The Tenderer
 - (c) Details To Accompany Technical Bid
 - (d) General Conditions Of Contract
 - (e) Special Terms And Conditions Of Contract
 - (f) Tender Form
 - (g) Agreement Form
 - (h) Performance Guarantee Form
 - (i) Warranty Form
 - (j) Manpower specific requirement
 - (k) Commercial Bid
 - (l) Questionnaire
 - (m) DGPS Station Instrument Details
3. The Tenderer is expected to examine the tender document carefully including all instructions, conditions, forms, special conditions, Manpower specific requirements etc. The Bidder has been advised to visit the site and satisfy himself about the site condition prior to quoting. Failure to furnish all information required by the tender document or submission of a tender not substantially responsive to the tender documents in every respect will result in “REJECTION OF TENDER BID” submitted by the individual Tenderer.
 - a. Canvassing in connection with tenders is strictly prohibited and the tenders submitted by the Tenderer who resort to any form of canvassing shall be summarily rejected.
 - b. Those Tenderer(s) whose near relatives are posted in any capacity in the Inland Waterways Authority of India (IWAI) shall not be permitted to bid. The prospective Tenderer shall also intimate the names of persons who are working with him in any capacity or subsequently employed by him & who are near relative to any officer in the IWAI or in the Ministry of Shipping.

Any breach of this condition by the Tenderer shall render him ineligible. By the term 'near relative' is meant wife, husband, parents and grandparents, children & grand children, brothers and sisters, uncles, aunts & corresponding in laws.

- c. No engineer of gazetted rank or other gazetted officer employed in engineering or administrative duties in an engineering Deptt. Of Govt. of India is allowed to work as a contractor for a period of two years after his retirement from Govt. service, without the prior permission of the government of India in writing. The contract is liable to be cancelled if either the contractor or any of his employees is found anytime to be such a person who had not obtained the permission of Govt. of India as aforesaid, before submission of the bid or engagement in the contractor's service.
4. The Chairman, IWAI reserves the right to reject any or all of the tenders received without assigning any reasons what so ever. He also reserves right for himself of accepting the whole or any part of the tender and Tenderer shall be bound to perform the same at the rates quoted. The tender in which, any of the prescribed conditions are not fulfilled or incomplete in any respect are liable to be rejected.
 5. At any time prior to the dead line for submission of tender, the Authority may for any reason, whether by its own initiation or in response to clarification requested by a prospective Tenderer, modify the tender document by amendments.
 - a. Pre-bid meeting will be held on 05.11.2014. at 1130 hrs. at IWAI, Noida. The decision taken during pred-bid meeting will replace / add the corresponding clauses / specifications already figured in the tender document and also form part of the specifications / other conditions of this tender document. The amendments shall be part of the tender document described at Clause-2 above and will be notified in writing or by e-mail to all prospective Tenderer, and would be dispatched with the bidding documents and will be binding on them.
 - b. In order to afford prospective Tenderer reasonable time in which to make amendment on this account in their tender document, the Authority may at its discretion fix fresh dead line for submission of bid.
 6. The tender document filled by the Tenderer and all correspondence and documents relating Tender and the bid exchanged by the Tenderer and the Authority shall be written in ENGLISH. Any document enclosed with the tender that is not in English shall be accompanied by the certified English translation.

7. EARNEST MONEY DEPOSIT (EMD)

The EMD shall be drawn in the form of Crossed Demand Draft (DD) from any Nationalized/ Schedule bank (Schedule I & II as per RBI guidelines) in favour of "INLAND WATERWAYS AUTHORITY OF INDIA FUND" payable at NOIDA / NEW DELHI. No other form of payment, e.g. Fixed Deposit, BG etc., shall be accepted

for EMD. No bidder shall be exempted from submission of EMD under any circumstances.

7.1 The successful Bidder(s) EMD will be converted into Security Deposit (SD) and the successful Bidder has to remit balance amount of SD in the form of Demand Draft (DD) / Bank Guarantee as per clause 9 of “General Conditions of the Contract”. However, the validity of BG shall be till expiry of the warranty / Guarantee period.

Those who are using downloaded tender document from the website shall submit the cost of tender document (Rs. 1000.00) in the form of separate DD along with EMD, while submitting the bid. The Bidders have options to quote for National Waterway-1 or 2 or both. Accordingly, EMD will be furnished alongwith technical bid.

Schedule	Location	Tender Cost	EMD (Lakhs)
Schedule “A”	National Waterway-1	Rs.1000/=	Rs.2.58
Schedule “B”	National Waterway-2		Rs.3.02
Schedule “A & B”	National Waterway-1 &2		Rs.5.60

7.2 The EMD may be forfeited if ,

- a] Tenderer withdraws his bid in part or in full or modifies his tenderer, during the period of bid validity specified on the bid form, or
- b] Make any modification in terms & conditions of tender, which is not acceptable to the Authority, then the Authority shall, without prejudice to any right or remedy, be at liberty to forfeit the EMD absolutely.
- c] The successful Tenderer fails to furnish in full all the information as required by the tender, withdraws his tender or refuses to sign the contract in accordance with Clause -15 of “Instructions to the Tenderer” on issue of letter of intent, or refuses to provide the Security Deposit in accordance with Clause 25 of “General Conditions of the Contract”.

7.3 The EMD will be returned to the unsuccessful Tenderer after finalization of the tender and no interest will be paid on EMD.

8. The bid shall not contain any erasure/over writing except as necessary to correct errors by the Tenderer in which case the person signing the bid shall initial such corrections(s).

8.1 Tender forms are not transferable and its cost is not refundable.

8.2 “Authority” will in no way be responsible for any expenditure incurred by the Tenderer in the preparation and submission of the tender.

9. Submission of Bid

Tender/Bid should be submitted in two covers viz. Envelope-1 (containing technical bid) and Envelope-2 (containing price bid) and both of these covers should be placed online in website <https://eprocure.gov.in/eprocure/app>

The first cover/envelope containing Part-1 shall be submitted online & hard copy along with the following documents (documents should be clearly annexed as per following serial number):-

- a) Scanned copy of Tender cost (Rs. 1,000/-) (Demand Draft in favour of IWAI fund payable at Noida).
- b) Scanned copy of Earnest Money Deposit as per clause 7 above.
- c) Scanned copy of Bank Solvency certificate from any nationalized /scheduled bank (as per clause 9.1.c).
- d) Scanned copy of Letter of Authority for signing and negotiation of bid.
- e) Scanned copy of duly filled "Tender Form".
- f) Scanned copy of duly filled up and signed tender acceptance letter.
- g) Scanned copy of Original bid document duly filled in and completed in all respects except prices, signed with rubber seal on each page as a proof of acceptance.
- h) Scanned copy of a signed declaration stating that no alteration has been made in any form in the downloaded tender document.
- i) Scanned copy of downloaded Minutes of the pre-bid meeting, sealed and signed as a proof of acceptance.
- j) Scanned copy of a declaration that Bidder have not been banned or de-listed by any Govt. or quasi Govt. agency or Public Sector Undertaking.
- k) Scanned copy of acceptance of payment terms clause 12 of "General Conditions of the Contract".
- l) Scanned copy of acceptance of "Terms of Reference for Overall maintenance, operation and security of DGPS Reference Stations (round the clock) in NW-1 & NW-2.
- m) Scanned copy of acceptance of guarantee clause 2 of "Special Conditions of the Contract".
- n) Scanned copy of acceptance to all tender terms & conditions to be confirmed.
- o) Scanned copy of Bidders Registration Certificate.
- p) Scanned copy of document in the respect of PAN, service tax, VAT number.
- q) Scanned copy of audit report / balance Sheet for the last three financial years (2014-15,2013-14 and 2012-13). Submitted Audit report / Balance Sheet should be clearly sealed & signed by the Auditor / Directors of the firm.
- r) Scanned copy of average annual financial turnover during last three years ending 31st March of the previous financial year, should be at least Rs. 39.00 lakhs for schedule A , Rs.46.00 lakhs and Rs.85.00 lakhs for both schedule. A statement is to be submitted clearly showing annual financial turnover for the years (2013-14 , 2012-13 & 2011-10).
- s) Scanned copies of similar work orders and performance certificates / job completion certificates for each individual item for which the bid is submitted, issued by the client during the past 7 years, for evaluation of financial & technical capabilities of

the bidders. Work orders and performance certificates / job completion certificates shall be in the name of bidder only, **clearly indicating the value of work.**

- t) Scanned copy of dully filled Questionnaire as in annexure-1
- u) Scanned copy of background of the organization with respect to similar experience and brief description of projects recently undertaken in the relevant field and list of the equipment maintained in various reputed Govt. / PSU's / Private sector organizations.
- v) The Bidder should have office in India to provide maintenance support. Scanned copy of addresses of Office and Service Center in India is to be provided.
- w) Scanned copy of list of any deviation from the enclosed conditions or contract, giving reference to the Article on which the Bidder proposes to deviate.
- x) Scanned copy of any other details which Bidder may feel relevant to carry out the present assignment.
- y) Scanned copy of duly filled details of Bank Account for Release of Payment through Electronic Fund Transfer System.

Note: -

1. The work experience of specialized firms / man power supplier providers in this field would be considered for evaluation.

2. The firm should be in existence for over 5 years in the trade with the operation and maintenance of similar machineries.

3. The firm must have expertise in preventive on-site maintenance and repair of marine equipment.

4. The Tenderer shall also submit the hard copies & soft copy of Tender in two sealed covers (apart from online copy) marked "Cover 1st" and "Cover 2nd". The Cover 1st shall contain the Earnest Money Deposit and technical bids. The Cover 2nd shall contain the Commercial bids. In case the first cover is not submitted with Earnest Money in a proper form, the second cover shall not be opened and rejected summarily. Both the Cover-1 & Cover-2 are to be placed in a single cover. Duly sealed covers containing the hard copies of technical and financial bids will be put in a separate single cover which should be sealed. The Second cover containing Part-2 shall be submitted along with the following documents:-

Price Bid (BoQ_XXXXX) as per format provided along with this tender.

In addition to online document, duly sealed covers containing the technical and financial bids will be put in a separate single cover which should be sealed and super scribed as **"Tender for Overall maintenance, operation and security of DGPS Reference Stations (round the clock) in NW-1 & NW-2" and "Don't Open before ----- at 1530 hrs"**.

The offer, complete in all respects, should be submitted by **1500 hours IST on ----- in the office of the Hydrographic Chief, Inland Waterways Authority of India, A-13, Sector-1, Noida-201301 (UP), India.**

“Authority” shall not be responsible for delay caused due to postal / courier or any other modes of delivery. Local Tenderer may, if so desire, deposit tenders in the tender box provided in the office for this purpose.

The Authority may at its discretion extend the dead line for the submission of bids in accordance with Clause – 5.b above, in which case all rights and obligation of the Authority and Tenderer previously subjected to the dead line will thereafter be subjected to the dead line as extended.

Late bids will be rejected and returned unopened to the Tenderer. Fax, E-mail and cable offers will not be considered under any circumstances. ***SUBMISSION OF HARD COPY OF TENDER IS MANDATORY.***

9.1 Technical Bid

The Envelope containing Technical bid will be sealed and super scribed **“Technical bid for Overall maintenance, operation and security of DGPS Reference Stations (round the clock) in NW-1 & NW-2”**.

The Tenderer shall submit the technical proposal keeping in view the operation and Maintenance of DGPS equipments and allied accessories at the venue of DGPS station and its net work. The list of equipments and its arrangement are placed annexure-2. **The technical proposal would include the following for evaluation of technical bids:**

- a. The Bank Solvency should be in the name of the Tenderer issued by banker with full address of issuing authority with validity. The value of Bank solvency shall not be less than for an amount as mentioned below:-

Schedule	Bank Solvency value
Schedule “A”	Rs.52.00 Lakhs
Schedule “B”	Rs.61.00 Lakhs
Schedule “A & B”	Rs.113.00 Lakhs

- b. Documentary evidence such as valid registration certificate for operation and maintenance of similar equipment and manpower supply for which the bidder intended to quote.
- c. The original tender document is to be duly filled in and submitted to the Authority along with technical bid, EMD and other documents in accordance with the instructions to the Tenderer.

It shall be absolutely necessary on the part of the Tenderer to sign the tender documents for all the components, parts. All pages of the bid shall be duly signed by the person/(s) signing the bid. The name of and position held by the person signing the bid must be typed or printed below the signature.

- d. The Tenderer will be required to give in writing a satisfactory assurance of its ability and intention to services pursuant to the contract within the time set forth therein.
- f. The bid shall remain valid for a period of 180 days from the date of opening the tender and contract value remains unchanged during contract period. No hike or revision is permitted.
- g. The Tenderer should have satisfactory service experience in operation and Maintenance of installed DGPS Equipment based on MF radio link in any other Organizations or for similar work. The names of the Department and places with addresses and Performance Certificates for those installations shall be furnished with tender documents.
- h. Copies of similar supply orders / performance certificates / job completion certificates for each individual item for which the bid is submitted, issued by the client during the past 7 years, for evaluation of financial & technical capabilities of the bidders.
- i. Average annual financial turnover during last three years ending 31st March of the previous financial year, should be at least for an amount as mentioned in the table given below:-

Schedule	Turnover
Schedule "A"	Rs. 39.00 lakhs
Schedule "B"	Rs.46.00 lakhs
Schedule "A & B"	Rs.85.00 lakhs

- j. Experience of having successfully completed similar works during last 7 years ending last day of month previous to the one in which this tender is invited should be either of following : (40-50-80)

Schedule	Details
Schedule "A"	(a) Three similar works each costing not less than Rs52.0 Lakhs.; or (b) Two similar works each costing not less than Rs. 65.0 Lakhs; or (c) One similar work completed not less than Rs. 104.0 Lakhs
Schedule "B"	(d) Three similar works each costing not less than Rs. 61.0Lakhs.; or (e) Two similar works each costing not less than Rs. 76.0Lakhs; or (f) One similar work completed not less than Rs. 121.0 Lakhs
Schedule "A & B"	(g) Three similar works each costing not less than Rs. 113.0 Lakhs.; or (h) Two similar works each costing not less than Rs. 141 Lakhs; or (i) One similar work completed not less than Rs. 225.0 Lakhs

- k. The tenderer should provide a list of the equipment installed in various reputed Govt. / PSU's / Private sector organizations or for operation of work.

- l. A proposal for overall maintenance, operation and security of DGPS Reference Station (round the clock) at each location for a period of 3 years from the date of signing agreement shall form part of the Tender. The work order will be issued initially for one year. Thereafter further extension of contract will be considered only after satisfactory performance of service which includes running and Maintenance of DGPS stations, keeping neat and tidy DGPS venue, manpower management, compliance of statutory requirement, etc. The performance certificate will be issued by Engineer In Charges representative in the field (i.e) IWAI Field Directors. The IWAI reserves the right to spilt the order for each locations and further extension of contract period on same term & conditions.
- m. The period of contract will be considered for the individual stations and would be undertaken by the successful bidder at various locations period as mentioned below:-

Location	Period
Swaroopganj (W Bengal)	February 2015
Bhagalpur (Bihar)	December 2014
Patna (Bihar)	February 2015
Jogighoppa (Assam)	December 2014
Silghat (Assam)	May 2015
Dibrugarh (Assam)	December 2014

- n. Valid latest Income Tax Return proof / Audit report / Balance Sheet for the last three years and Registration Certificate with attested copies as applicable shall be furnished with the technical bid. Copy of valid PAN Card is also to be submitted.
- o. The Tenderer must be registered with the following statutory authorities and must also furnish attested copies of supporting documents:-
- ESIC Registration
 - EPF Registration
 - PAN Registration
 - Service Tax Registration
 - Labour License
- p. The Tenderer shall give a declaration that they have not been banned or de-listed by any Govt. or quasi Govt. agency or Public Sector Undertaking.
- q. The firm should have infrastructure for operation and maintenance of GPS/DGPS Equipment in India with sufficient expertise to give back-up support and in operating and minor repairs of PCB, modules and units of the equipment for at least 10 years. A certificate from Main contractor/OEM supporting the claim of contractor shall be enclosed.
- r. All tenders are cautioned that tenders containing any deviations whatsoever from the terms and conditions, specifications as contained in the tender documents are liable to be rejected as non-responsive
- s. The technical proposal shall not contain any reference to the prices quoted.

Any other details which Tenderer may feel relevant to carry out the present assignment.

If there is any deviation from any condition, it should be clearly mentioned in the technical bid.

9.2 Financial Bid

- (a) Separate envelope containing financial bids should be sealed and superscripted as **“Price bid for Overall maintenance, operation and security of DGPS Reference Stations (round the clock) in NW-1 / NW-2”**. **Financial bid for each schedule to be sealed in a separately in order to evaluate separately.**
- (b) The Tenderer shall complete the schedule included herein stating the unit cost and total cost of manpower supply including management fee as indicated in the commercial bid form , complete in all respect, duly complying all requirements under the contract. **Prices quoted by the Tenderer shall remain firm and fixed and valid till the validity time.**
- (c) The rates quoted shall include cost for all essential and contingent expenditure incurred while performing their duties as mentioned in the following paragraph, which although not specifically mentioned in this contract, but are necessary for operation of the DGPS station. This shall include the cost of all required tools/tackles, plants, machinery and manpower etc. whatsoever applicable complete. Moreover, all the associated fittings, fixtures, accessories etc. are to be maintained to prevent any spoil/breakage etc. Other provisions as mentioned in the tender elsewhere are also included in the scope of work.
- (d) IWAI will provide necessary fuel, mobile oil and other consumables for running of DG sets. In addition, the payment for civil power supply will be borne by IWAI.
- (e) The Tenderer shall quote rate in figures as well as in words for amount tendered by him. Special care shall be taken to write the rates in figures and in words in such a way that interpolation is not possible. The total amount shall be written both in figures and in words. In case of figures, the word ‘Rs’ shall be written before the figures e.g. ‘Rs 2.15P’. In case of words the word ‘Rupees’ shall precede and the word ‘Paise’ shall be written at the end unless the rate is in whole rupee. The figures in word shall invariable be followed by the word ‘Only’. It would invariably be up to two decimal places. While quoting the rate in schedule of quantities in price schedule, the word ‘Only’ shall be written closely following the amount and it shall not be written in the next line.

- (f) The prices quoted shall be inclusive of service tax, insurance cover to the man power, ESI, Daily allowance, Travelling allowance to visiting Engineers and supervising staff, etc.
- (g) The bidder has to quote for salary of the staff/manpower and overhead charges/ management fee separately as mentioned in the Bill of Quantity for first year. The bidder has also to mention “percentage of Hike/escalation” required for forthcoming years (i.e) 2nd and 3rd year. The evaluation will be done overall for 3 year charges.

10. Bid Opening and Evaluation

The Authority shall open the technical bid in the presence of Tenderer representatives who choose to attend, at the opening time at the location prescribed for submission of bid under Clause-9 above.

Technical Bids will be evaluated and compared based on documents furnished as per Clause 9 of “Instructions to the Tenderer”, “Details to accompany tender bid” and “Manpower specific requirements”.

The Technical Evaluation shall be carried out in following areas to ascertain the quality of bid:-

Sl. No.	Area of Evaluation	Max Marks
1.	Presentation of documents and bid language	02
2.	Financial Capability of the bidder	10
3.	Details of project in hand and their status	03
4.	Technical Facilities, Resources & Project Management	10
5.	Details of Project Implementation Schedule pertaining to the Project	05
6.	Accreditation of any or all the partners by a quality assurance agency	02
7.	Experience in operation and maintenance of DGPS projects or similar Maritime offshore structure and machineries as pr prequalification criteria clause 9.1(j)	10
8.	Compliance of Technical man power requirement	50
9.	Any special features which enhances the capability of the system in future	08
	Total	100

Technical evaluation will be done by Technical Evaluation Committee (TEC). The commercial bids of those Tenderer failing to achieve marks less than 80% in technical evaluation shall not be considered and their commercial bids shall not be opened.

Price bids will be opened at a later date after evaluation of technical bids. The opening date for price bids will be informed to the Tenderer whose bids would qualify technically. Price bids will be evaluated and compared based on lowest prices quoted as per Clause 10 of “Instructions to the Tenderer” for individual item. No weightage carry over on technical evaluation shall be there at the time of financial evaluation. Overall maintenance, operation and security of DGPS Reference Station (round the clock) at each location will be compared for 5 years. Depending upon the satisfactory performance, the Overall maintenance, operation and security of DGPS

Reference Station (round the clock) at each locations may be extended further for 2 year on same terms & conditions and quoted / negotiated rates. Decision of “Authority” will be final in this regard.

11. Clarification of Bids

To assist in the examination, evaluation and comparison of bids the Authority shall at its discretion call the Tenderer for clarification on its bids including presentation. All responses to request for clarification shall be in writing within two days and no change in price or substance of the bid shall be sought offered or permitted. The Authority shall not be responsible for expenses for obtaining clarifications.

12. The Authority shall not bind itself to accept the lowest bid and reserves the right to split the order if necessary and also to accept or reject any or all bids or part thereof without assigning any reason whatsoever, prior to award of contract without thereby incurring any liability to the affected Tenderer or any obligation to inform the affected Tenderer of the ground for the Authority’s action.

13. The Authority reserves the right at the time of awards of order to split the order location-wise specified in the price schedule without any change in terms and conditions. The successful Tenderer will be bound to provide service at the same rate and terms & conditions.

14. The Authority will notify the successful Tenderer in writing that the bid has been accepted. The successful Tenderer will be required to enter into a contract with the Authority in the form given in these documents and has to submit Performance Guarantee as per Clause 27 of “General Conditions of the Contract”, within 10 days of award of work. Performance Guarantee(s) shall be kept valid till expiry of contract period.

15. The Authority shall forward a draft contract to the Tenderer along with award of work order. Within 10 days of receipt of such documents the successful Tenderer shall sign the contract on non-judicial stamp paper of Rs. 100/- under the terms and conditions as indicated in the “DRAFT CONTRACT” forwarded by the Authority. The contract shall be submitted in duplicate.

15.1 One copy of the Contract furnished to the successful Tenderer as aforesaid shall be kept by the successful Tenderer on each site in good order and the same shall at all reasonable time be available for inspection and use by the “Authority” or his representative or by other Inspecting officers of the Authority.

15.2 None of these documents shall be used by the successful Tenderer for any purpose other than that of this contract.

3. DETAILS TO ACCOMPANY TECHNICAL BID

Tenderer must submit his offer under this section with details of organisation of his establishment, registration, certificate, protect data sheet, experience, financial capabilities, etc. in evidence of their HR management, legal soundness in labour/staff management In addition to the parameters mentioned in product sheet, the Technical Evaluation Committee shall consider following points while evaluating Manpower specific requirement criteria of bid (Clause 10 of “Instructions to the Tenderer”). In addition, some other points may also be collected, which may be felt necessary by the Committee including a presentation on various technical aspects at Tenderer cost at Inland Waterways Authority of India, NOIDA.

- a) Tender cost (Rs. 1,000/-) (Demand Draft in favour of IWAI fund payable at Noida).
- b) Earnest Money Deposit as per clause 7 above.
- c) Bank Solvency certificate from any nationalized /scheduled bank (as per clause 9.1.c).
- d) Letter of Authority for signing and negotiation of bid.
- e) duly filled “Tender Form”.
- f) duly filled up and signed tender acceptance letter.
- g) Original bid document duly filled in and completed in all respects except prices, signed with rubber seal on each page as a proof of acceptance.
- h) a signed declaration stating that no alteration has been made in any form in the downloaded tender document.
- i) downloaded Minutes of the pre-bid meeting, sealed and signed as a proof of acceptance.
- j) a declaration that Bidder have not been banned or de-listed by any Govt. or quasi Govt. agency or Public Sector Undertaking.
- k) acceptance of payment terms clause 29 of “General Conditions of the Contract”.
- l) acceptance of “Terms of Reference for Overall maintenance, operation and security of DGPS Reference Stations (round the clock) in NW-1 & NW-2.
- m) acceptance of guarantee clause 2 of “Special Conditions of the Contract”.
- n) acceptance to all tender terms & conditions to be confirmed.
- o) Bidders Registration Certificate.
- p) copy of document in the respect of PAN, service tax, VAT number.
- q) copy of audit report / balance Sheet for the last three financial years (2014-15,2013-14 and 2012-13). Submitted Audit report / Balance Sheet should be clearly sealed & signed by the Auditor / Directors of the firm.
- r) copy of average annual financial turnover during last three years ending 31st March of the previous financial year, should be at least Rs. 30 lakhs. A statement is to be submitted clearly showing annual financial turnover for the years (2014-15,2013-14 and 2012-13).
- s) similar work orders and performance certificates / job completion certificates for each individual item for which the bid is submitted, issued by the client during the past 7 years, for evaluation of financial & technical capabilities of the bidders. Work orders and performance certificates / job completion certificates shall be in the name of bidder only, **clearly indicating the value of work.**
- t) Dully filled copy of Questionnaire as in annexure-1

4.GENERAL CONDITIONS OF CONTRACT

DEFINITIONS

In the contract, the following words & expressions shall, unless context otherwise requires, have the meaning thereby respectively assigned to them:

- (i) **IWAI/ Authority / Department / Owner** shall mean the Inland Waterways Authority of India, which invites tenders on behalf of the Chairman, IWAI and includes therein-legal representatives, successors and assigns.
- (ii) **Chairman:** means Chairman of Inland Waterways Authority of India.
- (iii) **Employer** means the Chairman, Inland Waterways Authority of India and his successors.
- (iv) **Engineer-In-Charge (EIC)** means the Engineer officer authorized to direct, supervise and be In-charge of the works for the purpose of this contract who shall supervise and be in charge of the work.
- (v) **Engineer-in-charge representative** shall mean any officer of the Authority nominated by the Engineer-in-charge for day to day supervision, checking, taking measurement, checking bills, ensuring quality control, inspecting works and other related works for completion of the project.
- (vi) **Contract:** means the documents forming the tender and acceptance thereof and the formal agreement executed between the competent authority on behalf of the Chairman, Inland Waterways Authority of India and the contractor, together within the documents referred to therein including these conditions, the specifications, designs, drawings and instructions issued from time to time by the Engineer-in-charge and all these documents taken together shall be deemed to form one contract and shall be complementary to one another.
- (vii) **Contract sum:** means the amount arrived at by multiplying the quantities shown in the schedule of quantities and price by the respective item rates as allowed.
- (viii) **Contractor:** means the successful Tenderer who is awarded the contract to perform the work covered under this tender document and shall be deemed to include the contractor's successors, executors, representatives or assignees as approved by the Engineer-in-charge.
- (ix) **Hydrographic Chief:** means the Hydrographic Chief of the Authority.
- (x) **Director** means the Director of the Authority, as the case may be.

- (xi) **Work Order** means a letter from the Authority conveying the acceptance of the tender/offer subject to such reservations as may have been stated therein.
- (xii) **Day:** means a calendar day beginning and ending at mid-night.
- (xiii) **Week:** means seven consecutive calendar days.
- (xiv) **Month:** means the one Calendar month.
- (xv) **Site** means the waterway and location as indicated in the document through which the works are to be executed.
- (xvi) **Work/works:** means work / works to be executed in accordance with the contract.
- (xviii) Schedules referred to in these conditions shall mean the relevant schedules annexed to the tender papers or the standard schedule of rates of the govt. mentioned with the amendments thereto issued up to the date of receipt of the tender.
- (xix) **District specifications** mean the specifications followed by the State Government in the area where the work is to be executed.
- (xx) **Tendered value** means the value of the entire work as stipulated in the letter of award.

INTERPRETATIONS

- a. Words imparting the singular only shall also include the plural; he includes she and vice-versa unless this is repugnant to the context.
- b. Heading and marginal notes in these General Conditions shall not be deemed to form part thereof or be taken into consideration in the interpretation of construction thereof of the contract.

1. General

- (i) The successful Tenderer (herein after called ‘Contractor’) shall satisfy himself in regard to the nature of service to be made, its scope, the conditions of contract, specifications, etc., included in the tender papers.
- (ii) The Tenderer (s) are advised to inspect and examine the site and its surroundings and satisfy themselves before submitting their tenders, in respect of the site conditions including but not restricting to the following which may influence or affect the work or cost thereof under the contract:
 - a) Source of extent of availability of suitable manpower, etc., required for work and Laws and Regulations governing their use and employment.

- b) Geological, meteorological, topographical, hydrological, morphological and other general features of the site and its surroundings as are pertaining to and needed for the performance of the work.
 - c) All other information pertaining to and needed for the work including information as to the risks, contingencies and other circumstances which may influence or affect the work or the cost thereof under this contract.
- (iii) The Tenderer shall note that information, if any in regard to the work site and local conditions as contained in these tender documents has been given merely to assist the Tenderer and is not warranted to be complete.
- (iv) For any item of work, the tendered rate shall be held to include all items as are clearly necessary for the proper execution of the work, notwithstanding the fact that any special items may not have been included in the specifications or shown on the drawings.
- (v) **DUTIES AND POWERS OF THE ENGINEER-IN-CHARGE REPRESENTATIVE**
- (a). The Engineer-in-Charge may, from time to time in writing, delegate to his representative any of the powers and authorities, vested in the Engineer-in-Charge and shall furnish to the Contractor a copy of all such written delegation of powers and authorities. Any written instruction or written approval given by the representative of the Engineer-in-Charge to the Contractor within the terms of such delegation shall bind the Contractor and the Authority as though it has been given by the Engineer-in-Charge.
 - (b) If the Contractor is dissatisfied with any decision of the representative of the Engineer-in-Charge, he will be entitled to refer the matter to the Engineer-in-Charge who shall thereupon confirm, reverse or vary such decision and the decision of the Engineer-in-Charge in this regard shall be final and binding on the Contractor.
 - (c) **URGENT WORKS:** If any urgent work (in respect where the decision of the Engineer-in-Charge shall be final and binding) becomes necessary, the contractor shall execute the same as may be directed, provided the directions are in accordance and confirmatory with provisions in contract.
- (d) **INSTRUCTION AND NOTICE**
- (i) Except as otherwise provided in this contract, all notices to be given on behalf of the Authority and all other actions to be taken on its behalf may be given or taken by the Engineer-in-Charge or any officer for the time being entrusted with the functions duties and powers of the Engineer-in-Charge.
 - (ii) All instructions, notices and communications etc. under the contract shall be given in writing and any such oral orders / instructions given shall be confirmed in writing and no such communication which is not given or confirmed in writing shall be invalid.
 - (iii) All instructions, notices and communications shall be deemed to have been duly given or sent to the contractor, if delivered to the contractor, his authorized agent, or left

at, or posted to, the address given by the contractor or his authorized agent or to the last known place of abode or business of the contractor or his agent of services by post shall be deemed to have been served on the date when in the ordinary course of post these would have been delivered to him and in other cases on the day on which the same were so delivered or left.

2. Subletting:

The contract shall not be assigned or sublet the work to 3rd party, which strictly not permitted under this contract. This shall be treated that the contractor is fail to complete the work and the work will be terminated with immediate effect with approval of Chairman, IWAI.

3. The contractor shall furnish adequate proof (along with the tender) to the effect to prove his capability in executing the work under the contract.

4. ARBITRATION

4.1 Except as otherwise provided herein before, all questions, disputes or difference in respect of which the decision has not been final and conclusive arising between the contractor and the authority in relating to or in connection with contract shall be referred for arbitration in the manner provided a under and to the sole arbitrator appointed as follows:

- (i) Either of the parties may give to the other notice in writing of the existence of such question dispute or difference.
- (ii) Within thirty (30) days of receipts of such notice from either party the Director / Dy. Director in charge of work at the time of such dispute shall send to the contractor a panel of three persons and there after the contractor within fifteen (15) days of receipt of such panel communicate to the Director / Dy. Director in charge the name of one of the person from such panel and such a person shall then be appointed a sole arbitrator by the Chairman “Authority”. However, the arbitrator so appointed shall not be an officer or the employee of the Inland Waterways Authority of India.
- (iii) Provided that if the contractor fails to communicate the selection of a name out of the panel so forwarded to him the Director / Dy. Director in charge than after the expiry at the aforesaid stipulated period the Chairman “Authority” shall without delay select one person from the aforesaid panel and appoint him as the sole arbitrator.

4.2 In the event of the arbitrator to whom the dispute is originally referred being transferred or vacating his office or being unable to act for any reason, then the Chairman shall appoint another person to act as sole arbitrator, such person shall be entitled to proceed with the reference from the stage at which, it was left by the predecessor.

- 4.3 The award of the arbitrator shall be final and binding the arbitrator shall decide in what proportion the arbitrator's fees, as well as the cost of Arbitration proceeding shall be borne by either party.
- 4.4 The arbitrator with the consent of the parties can enlarge the time, from time to time to make and publish his award.
- 4.5 The arbitrator shall give reasons for the award
- 4.6 The work under this contract shall continue during arbitration proceedings and no valid payments due from or payment by the authority shall be withheld on account of such proceedings except to the extent, which may be in dispute.
- 4.7 The Arbitration and Conciliation Act 1996 together with any statutory modifications or re-enactment thereof and the rules made there under for being in force shall apply to the arbitration proceeding under this Clause.
- 4.8 Arbitration proceedings shall be held at New Delhi.

NOTE: In case of contract with another public sector undertaking the Clause 4.1 to 4.8 shall stand deleted and the following arbitration Clause shall apply:

“Except as otherwise provided in case of a contract with a Public Sector Undertaking if at any time any question dispute or difference whatsoever arises between the parties upon or in relation to, or in connection with this agreement, the same shall be settled by arbitration in term of the Ministry of Industry, department of Public/enterprises O.M. No. 3/5/93-PMA dated 30.06.93 or any modification / amendments thereof.”

The Arbitrator shall have the power to enlarge the term to rate the award with the consent of the parties provided always that the commencement or continuation of the arbitration proceeding shall not result in cessation or suspension of any of other rights and obligations of the parties of any payments due to them hereunder.

The venue of the arbitration proceedings shall be at NOIDA/New Delhi. It is further clarified that both the parties to this agreement hereby undertake not to have recourse to civil to solve any of their dispute whatsoever, arising out of this agreement except through arbitration.

5. LAWS GOVERNING THE CONTRACT

- a. This contract shall be governed by, the laws of India for the time being in force.
- b. Irrespective of the place of delivery, the place of performance or place of payment under the contract, the contract shall be deemed to have been made at the place from which the acceptance of tender has been issued.
- c. Jurisdiction of Courts the courts of the place (New Delhi / NOIDA) from where the acceptance of tender has been issued shall alone have jurisdiction to decide any dispute arising out of or in respect of contract.

6. APPEAL

If the contractor desires to appeal against the decision of the Inspector against the rejection of any work as not being in accordance with the contract, he shall appeal to the Chairman within fourteen days after the Inspector's decision and if an appeal is so preferred, the decision of the Chairman on behalf of Authority shall be final and conclusive.

7. CHAIRMAN'S CERTIFICATE TO BE FINAL

Wherever in this contract provision is made for any question, arrangement, amount matter or things being settled, decided, certified or determined by the Chairman or by the Inspecting Authority or officer or by the representative or resting upon or being governed or controlled by or submitted to the judgment or opinion of them/him or any or them/their/his assessment, decision, certificate, determination judgment or opinion shall unless otherwise stated therein be final and conclusive for all purposes and shall be binding on the Authority and the contractor notwithstanding anything contained in this contract.

8. AUTHORITY AND THEIR STAFF NOT TO BE PERSONALLY LIABLE:

Nothing in these ports shall be deemed to or shall impose any personal liability of the Authority or their staff.

9. SECURITY DEPOSIT

9.1 Security Deposit including EMD already submitted will be 5% (five percent) of the contract value of the work. The EMD received from successful Tenderer will be converted as Security Deposit on signing of the agreement. **Balance Security Deposit (i.e. Total 5% SD deducting EMD submitted with technical bid) shall be paid in the form of Demand Draft before signing of Agreement.** Bank guarantee will not be accepted as security deposit

In addition, the Performance Guarantee shall be submitted in the form of DD/BG from a Nationalized within 10 days of award of work for an amount equal to 5% (five percent) of the contract value of the work. Performance Guarantee(s) shall be kept valid till expiry of Contract. (till completion of Operation and Maintenance period).

There shall not be any additional payment to the contractor for obtaining bank guarantees.

9.2 No claim shall lie against the purchase either in respect of interest or any depreciation in value of any security.

9.3 If the contractor fails or neglects to observe or perform any of his obligations under the contract, it shall be lawful for the Chairman or his duly authorized representative to forfeit either in whole or in part, the security deposit/encash the Performance Guarantee

furnished by the contractor. If the contractor duly performs and completes the contract in all respect and presents in absolute “**NO DEMAND CERTIFICATE**” in the prescribed form, the Chairman on behalf of authority shall refund the Performance Guarantee(s) and security deposit to the contractor after deducting all costs and other expenses that the purchaser may have incurred and all dues and other money including all losses and damages which the purchaser which is entitled to recover from the contractor.

(11) (a) Prices

The prices quoted by the Tenderer and accepted by the “AUTHORITY” shall remain firm and hold good till the completion of the works and no additional claims will be admissible on the account of any price variation of fluctuation in the market rates.

(b) Bid Prices

Tenderer may quote in Indian Rupees The payment to bidder will be made only in Indian Rupees. No provision exists for payments of foreign exchange to Tenderer.

The Tenderer shall indicate on the commercial bid the unit price and the total unit price of the service under this contract in the following manner:

- (1) Monthly salary of his manpower at various designation as per BIQ.
- (2) Management fee for each site
- (3) Over all service Tax of BIQ.

Any notified change in the service Tax (both increase and decrease) shall be to the “AUTHORITY” account. For such claims of variations, the Government notification as documentary evidence shall be produced by the Tenderer. Price variation due to any other cause shall be on contractor account.

12 .PAYMENT FOR OVERALL MAINTENANCE, OPERATION AND SECURITY OF DGPS REFERENCE STATION:-

50% amount of the total contract value of item of each site shall be paid after six month of deployment of manpower and balance 50% shall be paid after one year. In other words the payment shall be paid half yearly. The Period starts from date of deployment of manpower.

- i. Attendance register shall be submitted by the contractor monthly on or before the date fixed by the Engineer-in-charge for the personal deployed. The Engineer –in-Charge shall then arrange to have the bills verified with reference to the attendance register or any intermediate inspection thereof.
- ii. Payment on account for admissible shall be made the Engineer in Charge certifying the sum to which the contractor is considered entitled by way of payment for the personnel deployed , after deducting there from the amount already paid, the security deposit and such other amounts as may be withheld/deductible or recoverable in terms of the contract.

iii. TAX DEDUCTIOIN AT SOURCE

TDS at the applicable rate as per Income Tax Act / Rules shall be deducted from all the payment / advance made against the contract.

13. SYSTEM OF PAYMENT

Unless otherwise agreed in writing between Chairman on behalf of the Authority and the Contractor payment for the works shall be made by Chairman on behalf of Authority, through RTGS mode for the work completion. The contractor must submit the bills and necessary documents allowing 30 days from the date of submission for the payment.

14. Penalty / Liquidated Damages

- i) The “AUTHORITY” may, without prejudice to any other method of recovery, deduct the amount of such damages from any money in his hands, due or which may become due to the Contractor. The payment or deduction of such damages shall not relieve the Contractor from his obligation to complete the works or from any other of his obligations and liability under the contract.

- ii) **OVERALL, MAINTENANCE, OPERATION AND SECURITY OF DGPS REFERENCE STATION:-** The Contractor shall pay a sum equal to 0.05% of the cost of the value of the work for of the station for each day, if the station is not maintained or personnel as per Contract are not deployed on every such occasion provided that such sum will not exceed 10% of the Contract value for the site. If the contractor fails to maintain the station for more than 15 days, no payment shall be allowed for that quarter.

15. Force Majeure

(i) **Definition of Force Majeure**

“Force Majeure” means an exceptional event or circumstances:

- a) Which is beyond a Party’s control,
- b) Which such Party could not reasonably have provided against before entering into the Contract.
- c) Which, having arisen, such Party could not reasonably have avoided or overcome, and
- d) Which is not substantially attributable to the other Party?

Force Majeure shall include, but is not limited to, exceptional events or circumstances of the kind listed below, so long as conditions (a) to (d) above are satisfied:

- a) War, hostilities (whether war be declared or not), invasion, act of foreign enemies,
- b) Rebellion, terrorism, revolution, insurrection, military or usurped, or civil war,
- c) Riot, commotion, disorder, strike or lockout by persons other than the Contractor’s Personnel and other employees of the Contractor and Sub-Contractors.

- d) Munitions of war, explosive materials, ionizing radiation or contamination by radio-activity, except as may be attributable to the Contractor's use of such munitions, explosive, radiation or radio-activity, and
- e) Natural catastrophes such as unprecedented rain, earthquake, hurricane, typhoon or volcanic activity.
- f) Change in the Government licensing policy
- g) Any unforeseen event.

(ii) Notice of Force Majeure

If the Contractor is prevented from performing any of its obligations under the Contract by Force Majeure, then he shall give notice to the "AUTHORITY" of the event or circumstances constituting the Force Majeure and shall specify the obligation, the performance of which is or will be prevented. The notice shall be given within 15 days after the Contractor became aware, or should have become aware, of the relevant event or circumstances constituting Force Majeure.

The Contractor shall, having given notice, be excused performance of such obligations for so long as such Force Majeure prevents it from performing them.

NOTWITHSTANDING ANY OTHER PROVISION OF THIS CLAUSE, FORCE MAJEURE SHALL NOT APPLY TO OBLIGATIONS TO EITHER PARTY TO MAKE PAYMENTS TO THE OTHER PARTY UNDER THE CONTRACT.

16. WITHHOLDING AND LIEN IN RESPECT OF SUM CLAIMED

Whenever any claim or claims for payment of a sum of money arises out of or under the contract against the Contractor, the purchase shall be entitled to withhold and also have a lien to retain such sum or sums in whole or in part from the security, deposited by the Contractor and for the purpose aforesaid the purchase shall be entitled to withhold the said security deposit furnished and also have a lien over the same pending finalization or adjudication of any such claim. In the event of the security being insufficient to cover the claimed amount or amounts or if no security has been taken from the Contractor, the purchase shall be entitled of the such claimed amount or amounts referred to supra, from any sum or sums found payable or which at any time thereafter may become payable to the Contractor under the same contract or any other contract with the purchase or the government or any person contracting through the Chairman pending finalization adjudication of any such money so withheld or retained under the lien referred to above, by the purchaser will claim arising out of or under the contract is determined by the arbitrator.

17. OVER PAYMENTS AND UNDER PAYMENTS

17.1 Whenever any claim whatsoever for the payments of a sum of money to the Authority arises out of or under this contract against the contractor, the same may be deducted by the Authority from any sum then due or which at anytime thereafter may become due to the contractor under this contract and failing that under any other contract with the Authority or from any other sum whatsoever due to the contractor from the Authority or from the Authority or from his security deposit, or he shall pay the claim on demand.

17.2 The Authority reserves the right to carry out post – payment audit and technical examination of the final bill including all supporting vouchers, abstracts etc. The authority further reserves the right to enforce recovery of any over payment when detected not – withstanding the fact that the amount of the final bill may be included by one of the parties as an item of dispute before an arbitrator appointed under clause 4 of this contract and notwithstanding the fact that the amount of the final bill figures in the arbitration award.

17.3 If as a result of such audit and technical examination any over payment is discovered in respect of any work done by the contractor or alleged to have been done by him under contract, it shall be recovered by the Authority from the contractor by any of all of the methods prescribed above, and if any under payment is discovered, the amount shall be duly paid to the contractor by the Authority.

17.4 Provided that the aforesaid right of the Authority to adjust over-payment against amount due to the contractor under any other contract with the Authority shall not extend beyond the period of two years from the date of payment of the final bill or in case the final bill is a MINUS bill, from the date the amount payable by the Contractor under the MINUS final bill is communicated to the contractor.

17.5 Any sum of money due and payable to the Contractor (including the security deposit returnable to him) under the contract may be withheld or retained by way of lien by the Engineer-in-Charge or Authority against any claim of the Authority or such other person or persons in respect or payment of a sum of money arising out of or under any other contract made by the contractor with the Engineer-in-Charge or Authority or with such other person or persons. The sum of money so withheld or retained under this clause by the Engineer-in-Charge or Authority will be kept withheld or retained as such contract or any other contract is either mutually settled or determined by the arbitrator, if the contract is governed by the arbitration clause under the clause 22 or by the competent court hereinafter provided, as the case may be, and the contractor shall have no claim for interest or damages whatsoever on this account or any other ground in respect of any sum of money withheld or retained under this clause.

18. CONTRACT MATTERS TO BE TREATED AS CONFIDENTIAL

18.1 All documents, correspondence, decisions and orders concerning the contract shall be considered as confidential and/or restricted in nature by the contractor and he shall not divulge or allow access to them by any un-authorized person.

18.2 The contractor shall take necessary steps to ensure that all persons employed on any work in connection with this contract have noted that the Indian Official Secrets Act, 1923 (XIX of 1923) applies to them and shall continue so to apply even after the execution of such under the contract.

19. INDEMNITY

- (i) The Contractor shall not be liable for payment of any royalty, license fee or other expenses in respect of for making use of patents or designs with respect to which he is according to the terms of the contract, to be treated as an agent of the Government for the purpose of making use of the patent of trade mark for fulfillment of the contract.

20. CORRUPT PRACTICE

- (i)** The Contractor shall not offer or to give to any person in the employment of the purchaser or working under the orders of the Chairman any gift of consideration of any kind as an inducement or reward for doing or forbearing to do or for having done or forborne to do any act in relation to the obtaining or favour or disfavor to any person in relation to the contract or any other contract with the purchaser.

Any breach of the aforesaid condition by the contract, or any one employed, by him or acting on his behalf (whether with or without the knowledge of the Contractor) or the commission of any offence by the Contractor or by any one employed by him or acting on his behalf under chapter IX of the Indian Penal Code, 1860 or the preservation of Corporation Act, 1947 or any other Act enacted for the prevention of corruption by public servants shall entitled the Chairman on behalf of authority to cancel the contract and all or any other contracts with the Contractor and to recover from the Contractor the amount of any loss arising from such cancellation in accordance with the provisions of special condition and general condition.

- (ii)** Any dispute or difference in respect of either the interpretation effect or application of the above conditions or of the amount recoverable there under by the purchaser from the Contractor, shall be decided by the Chairman on behalf of authority.

5. SPECIAL TERMS AND CONDITIONS OF CONTRACT

1. General

- (i) All the future correspondences in this connection shall be addressed to the:

The Hydrographic Chief
Inland Waterways Authority of India
A-13, Sector – 1, NOIDA – 201 301 (U.P.)
Tel :0120) 2543931, 2522969,2527667
Fax (0120) 254 3973, 2544041, 2544005

- (ii) The “Authority” may terminate this contract at any time for unsatisfactory performance by the Contractor (s), for which “AUTHORITY” shall inform in writing and a proportionate amount, if any, shall be payable for that part of the supply only.

2. GUARANTEE FOR THE SERVICE FOR QUALIFIED PERSONAL FOR OPERATION AND MAINTENANCE

- (i) The manpower supplied under the contract shall be guaranteed that personal engaged for operation and maintenance of DGPS reference stations are qualified and experienced personal and they have valid educational and experience certificate for operation of equipment, instruments installed in the DGPS reference station. During the deployment period, the Contractor has to make all arrangement to rectify the defects ; this should be “free of cost at the ultimate destination”.
- (ii) Contractor shall warrant to the Authority that the services supplied under the contract will comply strictly with the contract shall be first class in every particular case and shall be free from defects. The Contractor further warrants to the Authority that all services by the Contractor for the purpose of the operation and maintenance will be of the most suitable grade, and for their intended purposes. The Contractor shall further warrant that the services to be carried out under this contract will confirm with generally accepted professional standards.
- (iii) On receipt of such notice, the Contractor shall promptly repair or replace the defective equipment or parts thereof.
- (iv) If the Contractor, having been notified, fails to remedy the defects (s) in accordance with the contract the Authority may proceed to take such remedial action as may be necessary at the Contractor expense. The Contractor warranty pursuant to this clause is without prejudice to any other rights or remedies, which the Authority may have against the Contractor under the contract.
- (v) The Contractor shall pay a sum equal to 0.05% of the cost of the Operation and Maintenance of the station for each day of the work that remains incomplete beyond

the stated period of 48 hours on every such occasion provided that such sum will not exceed 10% of the Contract value for the site. In case the Contractor fails to perform the preventive maintenance, which is to be carried out every quarter, the amount to be deducted as penalty shall be Rs.30,000/- for each quarter for the concerned station. If the contractor does not make visit for the two consecutive quarters, no payment shall be allowed.

(vi) Should it appear to the “AUTHORITY” at any time during the execution of the work that the maintenance /workmanship is unsatisfactory he shall have full powers to get the work done through some other contractor/firm as he may consider necessary for the proper execution of the work and shall debit the cost of such/expenses to the contractor which shall be the first charge upon the bill of the contractor.

a) Deployment of manpower

S. No.	Items	Period
1.	Award of work order	Zero date
2.	Submission of Performance Guarantee (5% of Contract Value)	Within ten days from the date of issuance of awarded of work order.
3.	Signing of agreement	Within ten days from the date of issuance of awarded of work order.
4.	Deployment of manpower at various stations as mentioned in BIQ	WITHIN 20 days FROM THE DATE OF ISSUANCE OF AWARD OF WORK ORDER 'OR' 7 days from the date of signing of agreement whichever is later.

6. TENDER FORM

To,

The Hydrographic Chief
Inland Waterways Authority of India
A-13, Sector – 1,
NOIDA – 201 301
U.P. India.

I/We have read the examined the following documents relating toas specified, of Inland Waterways Authority of India, Noida (IWAI):

- i. Tender notice
- ii. Instructions to the Tenderer
- iii. Details to Accompany Technical Bid
- iv. General Conditions of Contract
- v. Special Terms and Conditions of Contract
- vi. Tender Form
- vii. Warranty Form
- viii. Agreement Form
- ix. Performance Guarantee Form
- x. Manpower specific requirements

1. I/We hereby tender for the execution of the works referred to in the aforesaid document upon the terms and conditions contained or referred to therein and in accordance in all respects, with the specifications other terms and conditions of the contract and within the period of completion as stipulated in the tender document.

2. I/We agree to keep the tender open for acceptance for 180 days counted from the last date specified for the submission thereof and not to make any modifications in its terms and conditions, which are not acceptable to "Authority". We also agree that any terms or conditions in the tender at variance with the above stipulation will render the tender liable to rejection summarily.

3. Rs.....
.....(Rupees.....
..... (or) only as the case may be is attached herewith as Earnest Money.

4. If, after the tender is accepted, we fail to execute the contract deed within 10 days of the receipt of the order to do so, we agree that "Authority" shall without prejudice to any terms and conditions of the tender, forfeit the earnest money absolutely.

1. I/We undertake to commence the work within 20 (ten) days of the date of issue of the work order of "Authority" and to operate and maintenance whole of the system comprised in the contract OR 7 days from the date of signing of agreement whichever is later and fulfill all the terms and conditions and provisions of the aforesaid documents or in default thereof to forfeit the security at the hands of "Authority" the liquidated damages in terms of the contract.

2. Until a formal contract is prepared and executed this bid, together with your written acceptance thereof in your notifications of award shall constitute a part of the contract between us.

3. I/We understand that you are not bound to accept the lowest priced or any bid that you may receive.

Signature.....
 In the capacity of

.....
 Duly authorized to sign the
 Tender on behalf of (in block
 Capitals).....

.....

Witness.....
 Date.....
 Address.....

Postal Address.....

.....

Telephone No.....
 Telegraphic address.....
 E-mail.....

7. Agreement form

This agreement made on _____ day_year_____ between the Inland Waterways Authority of India (hereinafter called the `IWAI which expression shall unless excluded by or repugnant, to the context, be deemed to include heir, successors in office) on one part and M/S_____ (hereinafter called the CONTRACTOR which expression, shall unless excluded by repugnant to the context be deemed to include his heirs, executors, Administrators, representatives and assigns of successors in office) on the other part.

WHEREAS THE IWAI desirous of undertaking the works

_____ WHEREAS the contractor has offered to execute and complete such works and whereas IWAI has accepted the tender of the contractor and WHEREAS the contractor has furnished

_____ as security for the due fulfilment for all the conditions of this contract.

NOW IN THIS AGREEMENT WITNESSTH AS FOLLOWS

In this agreement words and expression shall have the same meaning as are respectively as assigned to them in the conditions of contract hereinafter referred to:

The following documents shall be deemed to form and be read and construed as part of this agreement VIZ.

1. Notice Inviting Tender
2. Instructions To The Tenderer
3. Details To Accompany Technical Bid
4. General Conditions Of Contract
5. Special Terms And Conditions Of Contract
6. Tender Form
7. Agreement Form
8. Performance Guarantee Form
9. Warranty Form
10. Manpower specific requirement
11. Commercial Bid
12. Questionnaire
13. DGPS Station Instrument Details

The contract agreement has been compiled by the IWAI from the original tender documents and all the correspondences from the tendering stage till acceptance. In the event of any difference arising from the completion of the contract, the original tender documents, contractors offer, minutes of meetings and correspondence between the party ended vide letter No._____ may be referred to by either party. These documents shall take precedence over the compiled documents.

The contractor hereby covenants with the IWAI to complete and maintain the “Works” in conformity in all respect, with the provisions of the agreement.

The IWAI hereby covenants to pay the contractor in consideration of such completion of works, the contract price at the time and in the manner prescribed by the contract.

IN WITNESS WHEREOF the parties hereunto have set their hands and seals on the day year first written.

For and on behalf of

For and on behalf of

(Inland Waterways Authority of India) Contractor

Signature _____

Signature _____

Name & Designation _____

Name & Designation _____

Stamp

Stamp

Witness:

Witness:

1) Signature _____

1) Signature _____

2) Name & Designation _____

2) Name & Designation _____

8. Performance Guarantee form
BANK GUARANTEE PROFORMA FOR FURNISHING
PERFORMANCE GURANTEE

To
The Chairman
Inland Waterways Authority of India
A-13, Sector-1
Noida- 201301

In consideration for the Chairman, Inland Waterways Authority of India hereinafter called „the Authority” having agreed, under the terms and conditions of the Agreement dated made between..... and ...for the due fulfillment of the said Agreement by the Contractor of the terms and conditions contained in the said Agreement, on production of Bank Guarantee for Rs..... (Rupees.....) at the request of..... Contractor(s), We (Bank) do hereby undertake to pay to the Authority an amount not exceeding Rs..... against any loss or damage caused to or suffered, or would be caused to or suffered by the Authority by reason of any breach of the said Contractor(s) of any of the terms or conditions contained in the said Agreement.

2. We..... do hereby undertake to pay the amount due and payable under this Guarantee without any demur, merely on a demand from the Authority stating that the amount claimed is due by way of loss or damage caused to or would be caused to or suffered by the authority by reason of breach by the said contractor(s) of any of the terms or conditions contained in the said Agreement or by reason of the contractor(s)“s failure to perform the said Agreement,. Any such demand made on the Bank shall be conclusive as regards the amount due and payable by the Bank under this guarantee. However, our liability under this guarantee shall be restricted to an amount not exceeding Rs.....

3. We undertake to pay the authority any money so demanded notwithstanding any dispute or disputes raised by the contractor(s) / suppliers(s) in any suit or proceeding pending before any court or Tribunal relating thereto liability under this present being absolute and unequivocal.

The payment so made by us under this Bond shall be valid discharge of our liability for payment there under and the contractor(s) / supplier(s) shall have no claim against us for making such payment.

4. We, further agree that the guarantee herein contained shall remain in full force and effect during the period that would be taken for the performance of the said Agreement and that it shall continue to be enforceable till all the dues of the Authority under or by virtue of the said Agreement have been fully and its claim satisfied or discharge or till..... Certify that the terms

and conditions of the said Agreement have been fully and properly carried out by the said Contactor(s) and accordingly discharges this Guarantee after..... years from the date of completion of the said contract unless a demand or claim under this Guarantee is served in writing on the bank but before the expiry of the said period of years in which case it shall be enforceable against the bank notwithstanding the fact that the same is enforced after the expiry of the said period ofyears.

5. We,.....further agree with the Authority that the Authority shall have the fullest liberty without our consent and without affecting in any manner our obligations hereunder to vary any of the terms and conditions of the said Agreement or to extend time of performance by the said Contractor(s) from time to time or to postpone for any time or from time to time any of the powers exercisable by the Authority against the said Contactor(s) and to forbear or enforce any of the terms and conditions relating to the said Agreement and we shall not be relieved from our liability by reason of any such variation, or extension being granted to the said Contractor(s) or for any forbearance, act or omission on the part of the Authority or any indulgence by the Authority to the said Contractor(s) or by any such matter or thing whatsoever which under the law relating to sureties would, but for the provision, have effect of so relieving us.

6. It shall not be necessary for the Authority to proceed against the Contractor before proceeding against the Bank and the Guarantee herein contained shall be enforceable against the Bank notwithstanding any security which the Authority may have obtained or obtain from the Contactor shall at the time when proceedings are taken against the Bank hereunder be outstanding or unrealized.

7. Notwithstanding anything contained herein above our liability under the guarantee is restricted to Rs..... and shall remain in force until.....Unless a claim or suit under this guarantee is filed with us on or before..... ALL OUR RIGHTS UNDER THE GUARANTEE SHALL BE FORFEITED and the bank shall be relieved and discharged from all liabilities therein.

8. This Guarantee will not be discharged due to the change in the constitution of the Bank or the Contractor(s) / supplier(s).

9. We,..... lastly undertake not to revoke this Guarantee during its currency except with the previous consent of the Authority in writing.

Dated thedate of.....200... for..... (indicate the name of Bank)

Signature.....

Name of the Officer..... (in Block Capitals) Designation of

Code No.....

Name of the Bank and Branch.

With complete address ,Phone, fax and e-mail.

9. Warranty form

M/s (hereinafter referred to as the tenderer) having carefully studied all the tender documents pertaining to the contract for “operation and maintenance of DGPS reference stations” and the local conditions having undertaken to execute the said works.

DO HEREBY WARRANT THAT:-

1. The Tenderer is familiar with all the requirements of the Contract.
2. The Tenderer has investigated the work site & also visited IWAI office and satisfied himself regarding the nature of work, and local conditions that may affect the work or its performance.
3. The Tenderer shall mobilize the necessary equipment, qualified & experienced manpower as per tender conditions.
4. The Tenderer is satisfied that the work may be performed and completed as required in the Contract.
5. The Tenderer accepts all risks directly or indirectly connected with the performance of the Contract.
6. The Tenderer has/had/have no collusion with other Tenderer, with any of the men of the Engineer-in-Charge or with any other person in Authority to execute. The said works according to the terms and conditions of the said Contract.
7. The Tenderer has not been influenced by any statement of promise of the Authority or E-I-C but only the Contract Documents.
8. The Tenderer is financially solvent.
9. The Tenderer is experienced and competent to perform the Contract to the satisfaction of the E-I-C.
10. The Tenderer is familiar with all General and Special Laws, Acts, Ordinances, Rules and Regulations of the Municipalities, District, State and Central Govt., that may affect the work, its performance or personnel employed therein.
11. I/We hereby give undertaking that the information, certificates and documents furnished by me/us with my/our offer and subsequently regarding works mentioned are true, correct, valid and complete to the best of my/us knowledge and nothing has been concealed/distorted any material as mentioned above I/We am/are agreeable for termination of Contract between me/us an Inland Waterways Authority of India regarding works mentioned in the tender without any notice, reason or compensation and non-issue of tender documents in future.

For and on behalf of the Tenderer

10. Manpower specific requirements

1. Overall maintenance, operation and security of DGPS reference stations (round the clock) at each location (Swaroopganj, Bhagalpur, Patna in NW-1 and at Jogighopa, Silghat & Dibrugarh IN NW-2) is to be provided by the Contractor.

2. No. of persons to be deployed under the charge of an Engineer are as follows:-
 - (i) Assistant Engineer (Engineer-In Charge) – 1 no for NW-1 and 2 separately
 - (ii) Technical Assistant – 3 nos. (on eight hours shift)
 - (iii) Security Guard – 3 nos. (on eight hours shift)
 - (iv) Attendant – 1 no.

3. The contractor shall provide the personnel as required above for overall maintenance, operation and security of DGPS Reference Stations (round the clock) at each location.
 - (i) The minimum qualification and essential / desirable experience for each technical personnel to be engaged shall be as follows:

Sr. No.	Name of Posts	No. of Posts	Qualification & Experience
1.	Assistant Engineer	1 no. for each waterway for monthly visit	Degree in Electronics & Telecommunication having 3 years experience in works related to DGPS Stations/power house/ cellular transmission /similar experience
2.	Technical Assistant	3 nos. (on eight hours shift)	Diploma in Electronics & Telecommunication having 3 years experience in works related to DGPS Stations/power house/ cellular transmission /similar experience
3.	Security Guard	3 nos. (on eight hours shift)	Having experience in similar nature of works for minimum 3 years
4.	Attendant	1 no.	Minimum 8 th class pass out capable of doing routine office works.

- (ii) Above personal are to be deployed from the date of signing of agreement.
- (iii) As 3 nos. Security Guards (3 nos) have been provided in the tender, hence it is the responsibility of the Contractor to provide the security arrangement for the whole installation area. However, IWAI will give necessary introductory letters to concerned local authorities indicating that the Contractor is providing security arrangement for and on behalf of IWAI.
- (iv) If any foreigner is employed by the contractor to work within the site the later shall ensure that such foreigner possesses the necessary special permit issued by the Civil Authorities in writing and also comply with the instructions issued therefore from time to time. The Contractor shall also take prior approval of the Authority before deploying any foreigner for the above work. In the event of any lapse in this regard on the part of such foreigner the contractor shall be personally held responsible for the lapse & Authority shall not be liable in any event.
- (v) No staff will take leave without prior permission and unless reliever is provided by the contractor for the above staff.
- (vi) The contractor shall issue an Identity card to each staff/worker and copy of same should be submitted to IWAI within three days of his deployment.
- (vii) The contractor shall maintain a muster roll and register of wages and has to submit the copy of same to IWAI within 10th date of every month.
- (viii) The workers/staff deployed should posses saving bank account number of Nationalized Bank and monthly wages are to be credited directly into their accounts. The documentary proof of payment paid to the workers/staff , , contribution and the employees contribution (PF, ESI, Bonus and Group Insurance) to the State insurance Scheme as per “the Employees State insurance Act 1948” as amended from time to time are to be submitted alongwith bill. For site engineers copy of PAN Card alongwith copy of Form 16 is to be submitted.
- (ix) The first aid box shall be kept in charge of person who shall be readily available during the working hours .
- (x) The fire extinguishers shall also be provided at Porta cabins (instrument & accommodation),Coil huts, Generators room.
- (xi) The contractor shall provided uniforms at his own expenditure to his staff and the staff should wear the uniform in neat and tidy condition while performing the duties.

4. DUTIES AND RESPONSIBILITIES:

- (i) **Assistant Engineer:** (BE/B-Tech in IT, Electronics , Computer) He shall be the Site Engineer and Incharge of the DGPS Station. He shall carry out routine checks ,tests on the equipments and all appurtenant and shall ensure that the

same are running satisfactorily. He shall ensure that the attendance records and all necessary registers/ proforma are updated. He shall remain present during the routine inspection of DGPS Station by Engineer In Charge of IWAI or his representative . In case of any shortfall/mishap he should promptly inform the concerned office and inform to the CAMC service provider on emergency basis. He should visit all DGPS stations under same National Waterway (NW-1 or NW-2). Minimum one visit is required for routine check in addition to any emergency /break down condition. He shall accompany the survey team once in 3 months to ensure that the equipments and DGPS Station are working well within their intended capacity and are receiving DGPS signals with corrections accurately. He shall stay within the premises of DGPS Station during inspection period. He shall not leave the premises without the prior permission of Engineer In charge of IWAI or his representative. No separate allowance for his field visit is permitted.

- (ii) **Technical Assistant:**(min 10+2, with knowledge of DG Set maintenance) shall operate the DGPS Station in 8 hours shifts and shall ensure that all the equipment's are in order. He shall operate DG set in the case of power supply break down. He shall monitor and should keep record of the output voltage of DG , RPM of DG, and the frequency of the O/P line , also He will maintain proper log book and history book for all machinery and equipment including dusting and oiling. In case of any of problem the Engineer In charge of DGPS Station is to be informed immediately and station should be shut down in case of heavy storm and rain by taking prior approval of DGPS site incharge. The shifts shall be rotated on fortnightly basis by the Engineer In Charge of DGPS Station. He shall stay within the premises of DGPS Station (provision for accommodation has been catered by IWAI). He shall not leave the premises without the prior permission of Engineer In charge of DGPS Station.

- (iii) **Security Guards:** They should be Physically fit and shall ensure the safety and security of the DGPS Station premises . They shall ensure that no unauthorized person enters the DGPS premises. In case of any trespass or any attempt of forceful entry he shall promptly inform the Engineer In charge of DGPS Station who in turn shall contact the concerned police station. The Engineer In Charge /representative of IWAI should also be intimated in writing within 12 hours of the incident. The deployed men shall be on 8 hours basis shifts which will be rotated on fortnightly basis by the Engineer In Charge of DGPS Station under intimation to IWAI . He shall stay within the premises of DGPS Station (provision for accommodation has been catered into by IWAI). He shall not leave the premises without the prior permission of Engineer In charge of DGPS Station

- (iv) **Attendant:** He shall ensure that the DGPS station is being kept tidy .He shall also work as a peon for delivery and receiving official document from IWAI office's as on when required

5. Monitoring of work:-

A monthly progress report containing Log book of DG sets, DGPS stations operating hours, Tool & Plant register, copy of attendance register duly signed by Assistant Engineer is to be submitted to respective field Director.

6. The contractor shall furnish and deliver copy of certified monthly attendance report to the Engineer-in-Charge of the personnel employed on the works. The contractor shall also submit on the 4th and 19th of every month for the period of second half of the preceding month and first half of the current month respectively to the Engineer-in-Charge, a true statement in respect of the following:

- (i) Any accidents if occurred during the said fortnight showing the circumstances under which they happened and the extent of damage and injury caused by them and,
- (ii) The Contractor shall pay to personnel employed by him either directly consolidated wages not less than wages as per State minimum labour wages and subsequent amendments if made from time to time.
- (iii) The Contractor shall in respect of personnel employed by him either directly comply with or cause to be complied with the contract labour (Regulation and Abolition) Act 1970 and Rules framed there under in regard to all matters provided therein.

7. The Contractor shall comply with the provision of all the Acts Laws, any Regulation or Bye Laws of any Local or other Statutory Authority if applicable in relation to the execution of works. Such as:

- (i) Payment of wages Act. 1936 (Amended)
- (ii) Minimum wages Act. 1948 (Amended).
- (iii) The Contract Labour (Regulation & Abolition) Act, 1970 with Rules framed there under as amended.
- (iv) Workmen Compensation Act. 1923 as amended by Amendment Act No. 65 of 1976.
- (v) Employer's Liability Act 1938 (Amended)
- (vi) The Industrial Employment (Standing orders) Act. 1946 (Amended).
- (vii) The Industrial Disputes Act. 1947 (Amended)

- (viii) Payment of bonus Act. 1965 if applicable and Amended Act No. 43 of 1977 and No. 48 of 1978 and any amended thereof:
 - (ix) The Personal Injuries (Compensation Insurance) Act. 1963 and any modifications thereof and rules made there under from time to time. The Contractor shall take into account all the above and financial liabilities in his quoted rates and nothing extra, whatsoever, shall be payable to him on this account.
 - (x) and all other applicable laws of the land.
8. The Contractor shall be liable to pay his contribution and the employees contribution to the State Insurance Scheme in respect of all personnel employed by him for the execution of the contract, in accordance with the provision of “the Employees State Insurance Act 1948” as amended from time to time. In case the Contractor fails to submit full details of his account of personnel employed and the contribution payable the Engineer-in-Charge shall recover from the running bills of the contribution and amount of contribution as assessed by him. The amount so recovered shall be adjusted against the actual contribution payable for Employees State Insurance.
9. The Engineer-in-Charge shall on a report having been made by an inspecting officer as defined in the Contract Labour (Regulation and Abolition) Act and Rules or on his own in his capacity as Principal Employer, have the power to deduct from the amount due to the contractor any sum required or estimated to be required for making good the loss suffered by staff/worker(s) by reason of non-fulfillment of the conditions of the Contract for the benefit of staff/Workers, non-payment of wages or of deduction made from him for wages which are not justified by the terms of the contract or non observance of the said Act and Rules framed there under with amendments made from time to time.
10. The Contractor shall indemnify the Authority against any payments to be made under and for observance of the Regulation Laws, Rules as stipulated in Clause-6 above without prejudice to his right to claim indemnity. In the event of the contractor’s failure to comply with the provisions of all the Act/Laws stipulated in Clause-6 or in the event of decree or award or order against the contractor having been received from the competent authority on account of any default or breach or in connection with any of the provisions of the Act/Laws/Rules mentioned in Sub-Clause 5 above, the Engineer-in-Charge without prejudice to any other right or remedy under the contract shall be empowered to deduct such sum or sums from the Bill of the contractor or from his security deposit or from other payment due under this contract or any other contract to satisfy within a reasonable time the provisions of the various Act/Laws/Rules/Codes as mentioned under Sub-Clause above, on the part of the contractor under the contract on behalf of and at the expenses of the contractor and make payment and/or provide

amenities/facilities/services accordingly. In this regard, the decision of the Engineer-in-Charge shall be conclusive and binding on the contractor.

11. In the event or the Contractor committing a default or breach of any of the provisions of the aforesaid Contract's Labour (Regulation and Abolition) Act and Rules as amended from time to time or furnishing any information or submitting or filling any form/Register/Slip under the provisions of these Regulations which is materially incorrect then on the report of the Inspecting officer as defined in the relevant Acts and Rules as referred in Clause 6 above, the Contractor shall without prejudice to any other liability pay to the Authority as liquidated damages for every default, breach or furnishing, making, submitting, filling materially incorrect statement as may be fixed by the Engineer-in-Charge. The decision of the Engineer in Charge in this respect shall be final & binding.
12. The Contractor shall at his own expenses Comply with or cause to be complied with the Provisions/Rules provided for welfare and health of Contract Labour in the Contract Labour (Regulation and Abolition) Act and other relevant Acts and Rules framed there under or any other instructions issued by the Authority in this regard for the protection of health and for making sanitary arrangements for workers employed directly or indirectly on the works. In case, the contractor fails to make arrangements as aforesaid, the Engineer-in-Charge shall be entitled to do so and recover the cost thereof from the contractor.
13. In the event of any injury, disability or death of any personnel in or about the work employed by the contractor, contractor shall at all time indemnify and save harmless the Authority against all claims, damages and compensation under the Workmen Compensation Act. 1923 as amended from time to time or in other Law for the time being in force and Rules there-under from time to time and also against all costs, charges and expenses of any smooth action by proceedings arising out of such accidents or injury, disability or death of a workmen and against all sum or sums which may with the consent of the contractor be paid to compromise or compound any claim in this regard. If any award, decree or order is passed against the contractor for recovery of any compensation under the Workmen Compensation Act, 1923, for any injury, disability or death of a workman by any competent court, the said sum or sums shall be deducted by the Engineer-in-Charge from any sum then due or that may become due to the contractor or from his security deposit or sale thereof in full or part under the contract or any other contract with the Authority towards fulfillment of the said decree, award or orders.
14. The Contractor shall obtain License/Registration under the Contract Labour Act 1970, if considered necessary after the issue of work order.

15. RISK OR LOSS DAMAGE TO THE AUTHORITY PROPERTY.

In case of any damage caused to the Authority's Assets due to negligence and carelessness by the Contractor employee/staff. The Contractor has to compensate for such losses.

15. (i) Only the experienced and qualified personnel shall be deployed for all categories of personnel having the valid degree/diploma (or as mentioned in clause 1(b) above) certificates issued by the University/Institution and same shall be produced in original attested at IWAI office for each personnel offered by the Contractor for verification.

(ii) The Contractor shall employ for the execution of the works only such persons as are skilled and experienced in their respective trades and Engineer-in-Charge shall be at liberty to object to and require the Contractor to remove from the works any persons employed by the Contractor for the execution of the works who, in the opinion of the Engineer-in-Charge, misconduct himself or is incompetent or negligent in the proper performance of his duties. The Contractor shall forthwith comply with such requisition and such person shall not be again employed upon the works without permission of the Engineer-in-Charge.

(iii) The Contractor shall remove any person, if the Director finds him unsuitable and replace him with suitable substitute within 10 days of written intimation in that regard by the Director.

(iv) IWAI reserve the right to terminate the contract of manpower supply any time before expiry of stipulated period by issue of one month's notice to the Contractor. For such foreclosure, no compensation for reduction in scope shall be payable to the Contractor.

(v) Engagement with IWAI shall not confer any right on an individual for preference in employment in IWAI or for his continuation in subsequent years.

**11. Commercial Bid.
Schedule A**

Overall maintenance, operation and security of DGPS Reference Stations at Swaroopganj,
Bhagalpur, Patna (National Waterway-1)

Sr. No.	Name of Posts	Unit	Total Requirement/ waterway	Monthly payment /fee (RS)	Months	Annual Payment
	1st year					
1.	Assistant Engineer for monthly inspection -1 No/waterway	Person	1		12	
2.	Technical Assistant(on eight hours shift) 3 persons/station x 3 stations	Person	9		12	
3.	Security Guard(on eight hours shift) 3 persons/station x 3 stations	Person	9		12	
4.	Attendant 1 person/station x 3 stations	Person	3		12	
5	Management fee to the contractor including profit	Fee			12	
	Sub Total					
	Service Tax					
	First year O&M Charge					
	Second year O&M Charge (to be indicated as percentage of 1 year amount)				%	
	Third year O&M Charge (to be indicated as percentage of 1 year amount)				%	
				Total Contract Value		

. (Rs. In word)

Schedule B

Overall maintenance, operation and security of DGPS Reference Stations at Jogighoppa, Silghat and Dibrugarh (National Waterway-2)

Sr. No.	Name of Posts	Unit	Total Requirement/ waterway	Monthly payment /fee (RS)	Months	Annual Payment
	1st year					
1.	Assistant Engineer for monthly inspection -1 No/waterway	Person	1		12	
2.	Technical Assistant(on eight hours shift) 3 persons/station x 3 stations	Person	9		12	
3.	Security Guard(on eight hours shift) 3 persons/station x 3 stations	Person	9		12	
4.	Attendant 1 person/station x 3 stations	Person	3		12	
5	Management fee to the contractor including profit	Fee			12	
	Sub Total					
	Service Tax					
	<u>Fist year</u> O&M Charge					
	<u>Second year</u> O&M Charge (to be indicated as percentage of 1 year amount)				%	
	<u>Third year</u> O&M Charge (to be indicated as percentage of 1 year amount)				%	
				Total Contract Value		

. (Rs. In word)

Questionnaire
Detailed Information on Contractors Experience and Financial viability

General :

1. Name & Address of the firm :

2. Status of the firm: (Private/Govt/Public Undertaking)

3. Registered office address:

Telephone..... Fax.....

4. Director's/Owners Name:

5. No. of employees working in the office : Skilled Unskilled

Permanent
Temporary

6. Qualifications & experience of the Director and other key staff proposed to engaged for above survey

7. Authorised capital of the company (in Rs. Lakhs only)

8. Have you been registered with any Govt. /Public Sector Organisation. (Yes/No), if so furnish the details

Technical :

Give details in a statement form of the work carried out by the firm during last 5 years.

- a) Type of similar Work done.
- b) Cost of each work done.
- c) Furnish details regarding target dates and actual dates of completion of works

with names and address of clients.

d) Please indicate the field of specialization of the firm/company in brief.

Relevant Experience :

a) Details of personnel.

b) Detailed bio data of personnel proposed to be deployed and state if they are presently employed in your firm.

c) Furnish list of similar job on hand along with deployment schedule

DGPS STATION INSTRUMENT DETAILS

A. Qualitative Specifications for Differential Global Positioning System (DGPS)

1. Preamble.

The Specifications pertain to the design of existing reference DGPS base stations and service as per RTCM SC-104 V 2.3 standard for differential NAVSTAR Satellites. Also the specifications pertain to a DGPS reference station and Integrity Monitor with PC using Marine MF DGPS data link to broadcast differential corrections. The DGPS system is used for requirements in marine and land application as mentioned below.

2. Configuration.

- 2.1 The DGPS Reference stations is consisting of two parallel systems each consisting of GPS receiver with antenna, a computerized data processor with computer, Modulator and interfacing equipment. The configuration is operating in service/main and standby mode shall automatically takeover. In addition, the configuration will select either main or standby transmitter depending on their serviceability status.
- 2.2 The DGPS reference station configuration is having Receiver Autonomous Integrity Monitor to provide timely warning to users, when the system falls out of tolerance limits. The Integrity monitor is consisting of DGPS Beacon Receiver, Navigator Receiver similar to reference station i.e. switchable to reference station, integrity monitor PC with monitor and system software. In addition, a local audio/visual alarm will be provided to alert the operator on duty in case of failure as mentioned above.
- 2.3 The Beacon control software at reference station will be able to log system performance data, which can be accessed remotely, if required from remote control and monitoring station.
- 2.4 The base station control software should have facility to generate reports at user definable intervals like week, month of user-defined parameters like logs, alarms, failures, etc. A provision for storing these data on hard disk for a period of three months is to be made. This is required to evaluate the performance of the system at a later date.
- 2.5 The engineering services shall form the part of this tender .
- 2.6 A provision at each reference station is existing to interface the system with a Central Remote Control and Monitor station.

- 2.7 If, due to any reason(s) the system is not performing within tolerance limits and beacon control system is not to bring the system back to normal operating state, an audio/visual warning will be relayed to operator on duty for attracting his attention.
- 2.8 Each DGPS reference station transmits correction via DGPS Beacon. A built in integrity monitor will continuously monitor the quality and reliability of transmission.
- 2.9. The public mains supply and stand by Diesel Alternator (DA) sets will be provided by the “Authority” at the station. The DGPS Reference Station shall be in continuous service (i.e. 24 hrs. Per day) throughout the life span of equipment.

The broadcast reliability is required to be better than 99%. The broadcast coverage is considered as area where the mariner gets DGPS service. In the coverage area, the broadcast signal level shall give better than 99.5% availability over 1 year, 99.85% continuity over a period of 3 hours and accuracy of better than 5m.

SL NO.	ITEM-DESCRIPTION	DETAILS
1.	WHIP ANTENNA	74 FT. ANTENNA , FOR TRANMISSION (MAKE VALCOM)
2.	ATU (ANTENNA TUNING UNIT)	for transmitting the RTCM signal and turning the impedance according with the frequency (320KHz.) (MAKE NAUTEL)
3.	RECEIVERS	<p>(a) 3 nos. GPS receiver for receiving and generating correction factor for corrected GPS signal.(MX 9525R)(RS1, RS2, IM)</p> <p>(b) 3 nos. choke ring antenna for receiving GPS signal from Satellite.</p> <p>(MX-Marine)</p> <p>(c) 2 nos. Modulator for modulating the signal and send the corrected signal to transmitter. (MX 9525M)</p> <p>(d) 1 nos. Beacon receiver for receiving what signal is sending.(MX 41R)</p> <p>(e) 1 nos. Tx controller which activate or deactivate RS1/RS2.</p>

		(f) 1 nos. desktop computer for controlling and monitoring the whole operation with BSC Software. (g) 1 nos. DMP Type Printer.
4.	Transmitter	1 nos. transmitter for power-up the signal and send to ATU unit. (MAKE Nautel)
5.	POWER BACKUP	(a) 1 nos. 5kva ups (10nos. 26 ah batteries) for transmitter and ATU Unit. (b) 1 nos. 3kva ups (6 nos. 26ah batteries) for backup receiver unit. (MAKE Hykon)
6.	AC unit	(a) 1.5 ton AC for cooling the instrument room. (b) 1 ton AC for cooling the Accommodation room. (MAKE LG)
7.	DG Sets	2 nos. (15Kva, 3 phase)DG set for Supply Power to DGPS Station.(MAKE Escort)

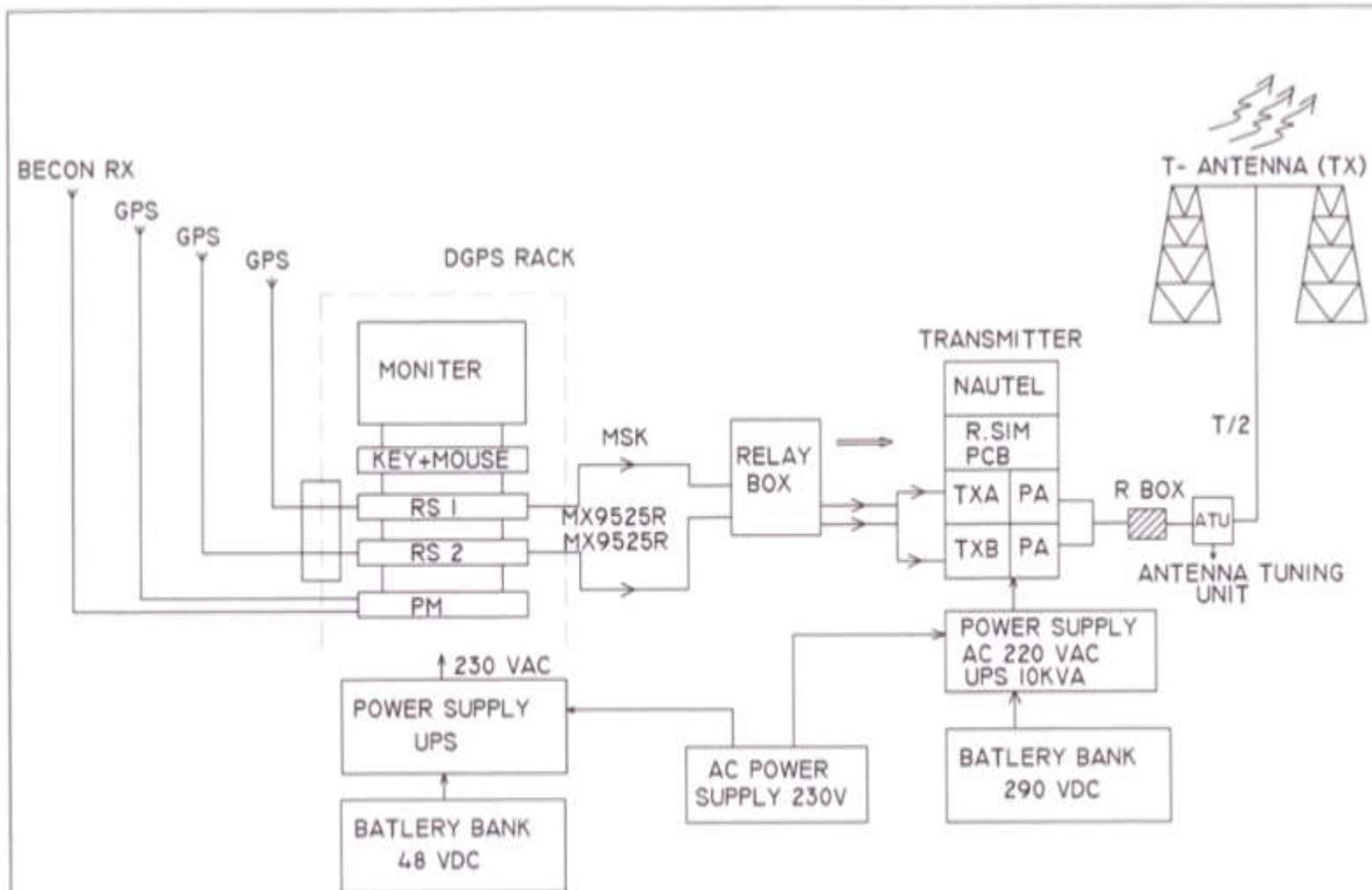

Tx A= TRANSMITTER A
 Tx B= TRANSMITTER B
 RS1= REFERENCE STATION 1
 RS2= REFERENCE STATION 2
 I M= INTEGRITY MONITOR

DGPS BHAGALPUR BLOCK DIAGRAM
DIFFERENTIAL GLOBAL POSITIONING SYSTEM
 FREQUENCY = 300 KHZ SERIAL No. - BI99