

Responses to pre-bid queries regarding Haldia MMT EOT

Queries regarding RFP

S No	Bidder name	S No as per bidder	Page no	Article no	Text provided in document	Queries with justification (if any)	IWAI response to bidders
1	Adani Logistics	1	8	1.1.1	The Estimated Project Cost ("Project Cost") of the terminal is approximately Rs.47.5 Crore	Please indicate the detailed break-up of the Estimated Project Cost.	Please refer Annexure I
2	Adani Logistics	2	9 13	1.2.4 2.1.8	In case a bank guarantee is provided, its validity period shall not be less than <u>180 (one hundred and eighty) days</u> from the Bid Due Date, <u>inclusive</u> of a claim period of 60 (sixty) days and may be extended as may be mutually agreed between the Authority and the Bidder from time to time.	Request you to please edit as below: In case a bank guarantee is provided, its validity period shall not be less than <u>120 (one hundred and eighty) days</u> from the Bid Due Date, <u>exclusive</u> of a claim period of 60 (sixty) days and may be extended as may be mutually agreed between the Authority and the Bidder from time to time.	No change, bid conditions prevail.

S No	Bidder name	S No as per bidder	Page no	Article no	Text provided in document	Queries with justification (if any)	IWAI response to bidders
3	Adani Logistics	3	9	1.2.7 (d)	The Concession Agreement period shall be for 10 (ten) years from the date of start of commercial operations ("COD") extendable by 5 (five) years.	Since, this terminal requires long term investments in specialized equipment the cost of which cannot be recovered completely within 10 years with 5 years extension. Typical debt period for the said equipment varies from 8-10 years. Thus it is not possible to fully utilize, depreciate and earn a decent return on capital within 10 years with 5 years extension. We request you to please agree for the following: "The Concession Agreement period shall be for 15 (fifteen) years from the date of start of commercial operations ("COD") extendable by 5 (five) years"	No change, bid conditions prevail
4	Adani Logistics	4	11	1.4	Pre-Bid Conference	Please suggest whether the pre-bid will be conducted through a Video Conference or at IWAI Noida office. Since, there are travel restrictions in our office which may remain in force for next 2 months, it is requested to keep it through Video Conferencing.	Please refer Corrigendum 2 to the bid.

S No	Bidder name	S No as per bidder	Page no	Article no	Text provided in document	Queries with justification (if any)	IWAI response to bidders
5	Adani Logistics	5	15	2.2.1 (a)	such that the sum total of (i), (ii) and (iii) is more than INR 118.8 crore (INR One hundred and eighteen crore and Eighty lakh only) cumulatively during the past 5 (five) financial years; and	<p>This project is of National Importance and will help in boosting the image of Inland Waterways in India. It must be noted that Govt. of India though IWAI has invested Rs 452 Crore in making this terminal and thus the eligibility criteria mentioned for the selection of the Concessionaire is a complete mismatch considering only minor additional investment of Rs 47.5 Crore.</p> <p>We believe, while making the eligibility criteria, the investment of Govt. of India shall also be taken into account and the operator must possess an experience of managing this scale of infrastructure.</p> <p>We request you to please keep the eligibility as under: 2.2.1 (a) "such that the sum total of (i), (ii) and (iii) is more than <u>INR 1,250 crore (INR One thousand Two Hundred and Fifty Crore)</u> cumulatively during the past 5 (five) financial years; and"</p> <p>2.2.1 (a) (iv) "An experience providing seaport terminal (containers, dry bulk, liquid bulk or general cargo)/ CFS/ ICD/ inland waterway terminal (containers, dry</p>	No change, bid conditions prevail.
6	Adani Logistics	6	15,16	2.2.1 (a) (iv)	An experience providing seaport terminal (containers, dry bulk, liquid bulk or general cargo)/ CFS/ ICD/ inland waterway terminal (containers, dry bulk, liquid bulk or general cargo) services and should have handled at least 5,372,500 (Five million three hundred seventy-two thousand and five hundred only) MT of cargo or 358,167 (Three hundred fifty-eight thousand one hundred	<p>We request you to please keep the eligibility as under: 2.2.1 (a) "such that the sum total of (i), (ii) and (iii) is more than <u>INR 1,250 crore (INR One thousand Two Hundred and Fifty Crore)</u> cumulatively during the past 5 (five) financial years; and"</p> <p>2.2.1 (a) (iv) "An experience providing seaport terminal (containers, dry bulk, liquid bulk or general cargo)/ CFS/ ICD/ inland waterway terminal (containers, dry</p>	No change, bid conditions prevail.

S No	Bidder name	S No as per bidder	Page no	Article no	Text provided in document	Queries with justification (if any)	IWAI response to bidders
					and sixty seven only) Twenty Foot Equivalent Units ("TEUs") cumulatively during the past 5 (five) financial years. For calculation purpose, the conversion rate of 1TEU=15 MT shall be used.	bulk, liquid bulk or general cargo) services and should have handled at least <u>15 million</u> (fifteen million only) MT of cargo or <u>1 million</u> (one million only) Twenty Foot Equivalent Units ("TEUs") cumulatively during the past 5 (five) financial years. For calculation purpose, the conversion rate of 1TEU=15 MT shall be used." 2.2.1 (b) "Financial Capacity: The Bidder shall have a minimum Net Worth ("Financial Capacity") of INR 250 crore (INR two hundred and fifty crore only) at the close of the financial year immediately preceding the Bid Due Date."	
7	Adani Logistics	7	16	2.2.1 (b)	Financial Capacity: The Bidder shall have a minimum Net Worth ("Financial Capacity") of INR 23.8 crore (INR Twenty three crore and eighty lakh only) at the close of the financial year immediately preceding the Bid Due Date.	3.1.2 9 (c) "The capital cost of the project should be more than INR 100 crore (INR Hundred crore only)"	No change, bid conditions prevail.

S No	Bidder name	S No as per bidder	Page no	Article no	Text provided in document	Queries with justification (if any)	IWAI response to bidders
8	Adani Logistics	8	30	3.1.2 (c)	The capital cost of the project should be more than INR 9.5 crore (INR Nine crore and fifty lakh only)		No change, bid conditions prevail.
9	Adani Logistics	9	20	2.5.1	The Bidders are encouraged to submit their respective Bids after visiting the Project site and ascertaining for themselves the site conditions, traffic, location, surroundings, climate, availability of power, water and other utilities for construction, access to site, handling and storage of materials, weather data, applicable laws and regulations, and any other matter considered relevant by them.	At present, in view of the COVID-19 travel restrictions, we may not be able to make the site visits for the technical evaluation. Please furnish the details such as dedicated/ common user facility, maximum permitted utilization limits of the utilities, service provider, any fixed charges to be paid per annum with/ without usage etc. for water, electricity and sewer connection. Any other charges to be paid to the local authorities. It is requested that the detailed specifications of the terminal equipment to be furnished to us including but not limited to type, make, standard, brochures, technical specifications, maintenance schedule, warranty period, defect liability period etc.	Please refer corrigenda regarding extension of bid schedule

S No	Bidder name	S No as per bidder	Page no	Article no	Text provided in document	Queries with justification (if any)	IWAI response to bidders
10	Adani Logistics	10	25	2.12	The Bidder shall provide documents mentioned in Articles 2.12.2(b), 2.12.2(c), 2.12.2(d), 2.12.2(e), 2.12.2(h) in original to the address provided in Article 2.12.3. The envelope shall then be sealed in an outer envelope which shall also be marked in accordance with Articles 2.12.2 and 2.12.3.	Please suggest whether the hard copies of the bids are to be submitted before the Due Date. In current situation, there are delays in postage/ courier. In view of this, it is requested that the bid shall be processed and evaluated in soft copies and delays in receipt of hard copies shall not result in disqualification of the bid.	Soft copy submission of bid documents. Hard copies (of required documents) to be submitted latest by Bid Due Date
11	Adani Logistics	11	30	3.1.1	O&M, development and construction projects in the following sectors would be considered as Eligible Projects.	Since this is a Equip, Operate and Transfer (EOT) model, it doesn't seem a fit to include construction projects for eligibility. We request you to please revise it as below:	No change, bid conditions prevail.
12	Adani Logistics	11	15	2.2.1 (ii) (a)	Paid for, or received payments for, construction of Eligible Projects as specified in Article 3.1; and/or	"O&M and development projects in the following sectors would be considered as Eligible Projects". 2.2.1 (a) (ii) "Deleted"	No change, bid conditions prevail.

S No	Bidder name	S No as per bidder	Page no	Article no	Text provided in document	Queries with justification (if any)	IWAI response to bidders
13	Adani Logistics	12	72	Annex XII	Brief Description of Multimodal Terminal at Haldia	Please clarify, the number of MHC (s) required to be deployed by the Concessionaire. As per the RFP, it is mentioned as 2 nos. whereas, 25. Annexure III: Scope of Work on Page 100 of the DCA it is stated as 1 nos.	Please refer Annexure I (of this document) Please refer Annexure III (of Draft Concession Agreement) Please refer amendment 9

14	HIPL	1	7	1.1.1	<p>The estimated project cost (“Estimated Project Cost”) of the Project at the Terminal is approximately INR 47.5 crore (INR Forty seven crore and fifty lakh only).</p> <p>Additionally, the Authority is investing approximately INR 452.2 crore (INR Four hundred fifty two crore and twenty lakh only) and is expected to invest approximately INR 19 crore (INR Nineteen crore only) on railway connectivity.</p>	<ol style="list-style-type: none"> 1. Authority to provide the detailed break up of Estimated Project Cost of INR 47.5 cr. Please note that as per Scope of Work, Annexure III of Concession Agreement , the Terminal Equipment Phase shall include addition of 1 MHC and 10 Dumper Trucks which as per DPR Sec 16.1 would cost INR 20 cr. 2. Authority to confirm that the cost of INR 47.5 cr does not include any land acquisition and land development cost, as the entire land area acquisition and development should be the Concessioneing Authority's responsibility. 3. Please clarify on the current status of investment of INR 452.2 cr along with the detailed break up of the cost. Apart from the INR 452.2 cr of investment has Authority incurred any other costs towards Terminal's Assets. 4. Please provide the current status (including land acquisition) and the estimated project timelines for rail connectivity. 5. The provision of rail connectivity should be part of obligation of Concessioneing Authority under the Concession Agreement. Please confirm 	<ol style="list-style-type: none"> 1. Please refer Annexure 1 2. Total project cost of INR 47.5 crore does not include land cost 3. Infrastructure development is at advanced stages of completion. Please refer Annexure 1. 4. Land has been leased from KOPT. Rail connectivity development shall be completed in 24 months after award of EPC contract for the same. 5. No change, bid conditions prevail.
----	------	---	---	-------	------------------------------------------------------------------------------------------------------------------------------------------------------------------------------------------------------------------------------------------------------------------------------------------------------------------------------------------------------------------------------------------------------------------------	---------------------------------------------------------------------------------------------------------------------------------------------------------------------------------------------------------------------------------------------------------------------------------------------------------------------------------------------------------------------------------------------------------------------------------------------------------------------------------------------------------------------------------------------------------------------------------------------------------------------------------------------------------------------------------------------------------------------------------------------------------------------------------------------------------------------------------------------------------------------------------------------------------------------------------------------------------------------------------------------------------------------------------------------------------------------------------------------------------------------------------------------	------------------------------------------------------------------------------------------------------------------------------------------------------------------------------------------------------------------------------------------------------------------------------------------------------------------------------------------------------------------------------------------------------------------------------------------------------------------

S No	Bidder name	S No as per bidder	Page no	Article no	Text provided in document	Queries with justification (if any)	IWAI response to bidders
15	HIPL	2	7	1.1.7	The scope of work for the Concessionaire shall comprise responsibility the following: (a) To operate, manage and maintain Terminal infrastructure (b) To equip Terminal infrastructure for augmenting Terminal capacity to 3.07 mmtpa	Please provide details of current capacity of the existing terminal (Terminal's Assets) both at berth side and back up area. Please provide details on any existing operations being carried out at the Terminal including commodities and historical volumes handled.	Please refer DPR for design and capacity details of Terminal Operations have not been commenced at the Terminal.
16	HIPL	3	7	1.1.5 & 2.2.3	The Selected Bidder shall be required to incorporate an SPV under the Companies Act, 2013	In case of a single Bidder /Applicant , Special Purpose Vehicle would not be necessary . Authority requested to consider and relax the requirement of formation of SPV for single Bidder accordingly.	No change, bid conditions prevail.

S No	Bidder name	S No as per bidder	Page no	Article no	Text provided in document	Queries with justification (if any)	IWAI response to bidders
17	HIPL	4	9	1.2.7(b)	<p>The Selected Bidder shall pay a Royalty (“Royalty”) in terms of INR per metric ton (“MT”) of Riverine Cargo (“Riverine Cargo”) handled at the Terminal to the Authority (“Bid Parameter”).</p> <p>Additionally, for Non-Riverine Cargo (“Non-Riverine Cargo”) handled at the Terminal, the Selected Bidder shall pay to the Authority a royalty amounting to the Royalty quoted for Riverine cargo plus a premium of 20% (twenty percent) on Royalty quoted for Riverine cargo</p>	<p>Please confirm the royalty amount quoted as bid parameter would be the applicable royalty (INR per mT) payable commencing from COD</p> <p>Authority requested to keep the Royalty payment structure conditions for non-riverine cargo similar to riverine cargo</p>	<p>All royalty payments (for riverine and non-riverine cargo) shall be applicable from COD</p>

S No	Bidder name	S No as per bidder	Page no	Article no	Text provided in document	Queries with justification (if any)	IWAI response to bidders
18	HIPL	5	10	1.2.7 (e)	The Concessionaire shall pay to the Authority a cargo volume-based payment commensurate to Royalty quoted for riverine cargo as given in Article 1.2.7 (b) for the period commencing from the COD till the end of the Agreement Period or on termination whichever is earlier	It is anticipated that in the initial years the traffic at the terminal would be quite low owing to competitive factors from other modes of transportation and the evolving hinterland. As such , payment of Royalty from the COD would impact the viability of the project. Thus for the benefit of the project, Authority is requested provide Royalty moratorium for first 4 years.	No change, bid conditions prevail
19	HIPL	6	9	1.2.7 (d)	The Concession Agreement period shall be for 10 (ten) years from the date of start of commercial operations (“COD”) extendable by 5 (five) years	As the gestation period for inland waterway project is likely to be higher owing to limited traffic potential in initial years, Authority is requested to grant Concession Period for at least 20 years from COD with a provision for further extension by 5 years to allow for a sufficient period for return on investment.	No change, bid conditions prevail

S No	Bidder name	S No as per bidder	Page no	Article no	Text provided in document	Queries with justification (if any)	IWAI response to bidders
20	HIPL	7	10	1.2.9	The Concessionaire shall, in consideration of its investment and services, be entitled to levy and recover Tariff from the users of the Project Facilities and Services.	Please provide definition of Project Facilities and Services	Please refer Article 1 of Draft Concession Agreement
21	HIPL	8	10	1.3	Schedule of Bidding Process	Authority to note that Bidder would require to study this project in great detail and also carry out necessary site visits and studies (commercial, technical etc) for which a minimum time frame of about 90 days is required. Further, clarity obtained after reply to queries are received by the Bidder would play a key role in the process of carrying out the evaluation. Hence, Authority is requested to extend the Bid Due Date to at least 3 months from the date of issue of written responses to Bidder's queries following the last Pre-Bid Meeting.	Please refer Corrigendum 3

S No	Bidder name	S No as per bidder	Page no	Article no	Text provided in document	Queries with justification (if any)	IWAI response to bidders
22	HIPL	9	15	2.1.15	<p>1. Bidder shall be liable for disqualification and forfeiture of Bid Security if any legal, financial or technical adviser of the Authority in relation to the Project is engaged by the Bidder, its Members or any Associate thereof</p> <p>2. Nor will this disqualification apply where such adviser is engaged after a period of 3 (three) years from the date of commercial operation of the Project.</p>	<p>1. Authority requested to provide the names of all its advisors related to the Project</p> <p>2. Authority requested to reduce this period to one year from the COD</p>	<p>1. Please refer Annexure 17</p> <p>2. Please refer amendment 3</p>

S No	Bidder name	S No as per bidder	Page no	Article no	Text provided in document	Queries with justification (if any)	IWAI response to bidders
23	HIPL	10	15	2.2.1	<p>Technical Capacity: For demonstrating the technical capacity and experience (“Technical Capacity”), the Bidder shall, during the past 5 (five) financial years preceding the Bid Due Date, shall have:</p> <p>(i) Collected and appropriated revenues from O&M of Eligible Projects in sectors specified in Article 3.1; and/or</p> <p>(ii) Paid for, or received payments for, construction of Eligible Projects as specified in Article 3.1; and/or</p> <p>(iii) Paid for development of Eligible Projects specified in Article 3.1</p> <p>such that the sum total of (i), (ii) and (iii) is more than INR 118.8 crore (INR One hundred and</p>	<p>Please confirm that the Bidder need not necessarily demonstrate capacity and experience in all the criteria indicated under 2.2.1 (i), 2.2.1(ii) and 2.2.1 (iii). That any combination of experience mentioned in (i), (ii) and (iii) such that the sum total of them is more than INR 118.8 crore (INR One hundred and eighteen crore and Eighty lakh only) cumulatively during the past 5 (five) financial years along with 2.2.1 (iv) will suffice. And accordingly only the relevant certificates need to be attached as per 2.2.2</p>	<p>Bidder to demonstrate cumulative minimum experience of INR 56.25 crore under 2.2.1 (i), 2.2.1(ii) and 2.2.1 (iii).</p> <p>Only relevant certificates need to be attached.</p>

S No	Bidder name	S No as per bidder	Page no	Article no	Text provided in document	Queries with justification (if any)	IWAI response to bidders
					eighteen crore and Eighty lakh only) cumulatively during the past 5 (five) financial years; and		

S No	Bidder name	S No as per bidder	Page no	Article no	Text provided in document	Queries with justification (if any)	IWAI response to bidders
24	HIPL	11	16	2.2.2 (b)	Certificates from its statutory auditors specifying the revenue of the Bidder in respect of the Eligible Projects specified in Article 2.2.1(a) (iii) above.	The clause may be reworded as " Certificates from its statutory auditors specifying the revenue of the Bidder in respect of the Eligible Projects specified in Article 2.2.1(a) (i) above"	Please refer amendment 2
25	HIPL	12	19	2.2.9	For the avoidance of doubt, financial year shall, for the purposes of a Bid hereunder, mean the accounting year followed by the Bidder in the course of its normal business.	Please confirm , in case an Associate of Bidder follows calender year as the financial year, the Technical and Financial capacity of such an Associate, as per Sec 2.2.1 (a) & 2.2.1 (b), for the corresponding calendar years would be acceptable.	Applicant may provide financial details as per financial year followed in its country
26	HIPL	13	21	2.6.2	The Authority reserves the right to reject any Bid and appropriate the Bid Security if: (a) at any time, a material misrepresentation is made or uncovered, or	Kindly define what constitutes "material misrepresentation"	Please refer Article 5.3 (b) of RFP

S No	Bidder name	S No as per bidder	Page no	Article no	Text provided in document	Queries with justification (if any)	IWAI response to bidders
27	HIPL	14	26	2.12.2 (g)	Copies of Bidder's duly audited balance sheet and profit and loss account for the preceding 5 (five) years;	Please confirm if the Bidder is incorporated within the preceding 5 (five) years then submission of audited financials from such year of incorporation would be accepted as criteria for evaluation.	A self certificate in this regard may be asked from the applicant that its Associate/Parent company is older than 5 years and holds more than 51% shareholding and its financial statements are being shared
28	HIPL	15	26	2.12.2	The envelope comprising individual envelopes for Technical Bid and Financial Bid respectively shall clearly bear the following identification: "Bid for Proposal: Multimodal Terminal Project at Haldia"	Please confirm that the Financial Bid as per format mentioned in Annexure I need not be submitted in hard copy (original).	Bids to be submitted as per provisions of Article 2.12 of RFP 1. Financial bid shall not be submitted in hard copy 2. Annexure I (of RFP) containing Financial Bid shall be submitted as a separate envelop in soft copy over eprocure platform

S No	Bidder name	S No as per bidder	Page no	Article no	Text provided in document	Queries with justification (if any)	IWAI response to bidders
29	HIPL	16	31	3.2.2	In case the annual accounts for the latest financial year are not audited and therefore the Bidder cannot make it available, the Bidder shall give an undertaking to this effect and the statutory auditor shall certify the same.	Please provide the suggested format (if any) of the undertaking and the Statutory Auditor certificate	The undertaking may be provided in appropriate format by bidder
30	HIPL	17	50	Annexure IV	In case the Bid Due Date falls within 6 (six) months of the close of the latest financial year, refer to Article 2.2.9.	Please confirm in case the audited financials are not available for latest financial year, the Bidder can submit the Net Worth corresponding to the financial year preceding the latest financial year	Confirmed as per 2.2.9 of RFP

S No	Bidder name	S No as per bidder	Page no	Article no	Text provided in document	Queries with justification (if any)	IWAI response to bidders
31	HIPL	18	72	Annexure XII	Brief Description of Multimodal Terminal at Varanasi	<p>Please provide a AUTO CAD file drawing of the layout map of the 61 acres of envisaged total area.</p> <p>Please confirm that the entire envisaged land area had been acquired/taken on lease. If not please provide the status and expected timeline of completion of acquisition/leasing of pending parcels.</p>	Please refer Annexure 3 (to this document)
32	IRC	1	9	1.2.7.(d)	The Concession Agreement period shall be for 10 (ten) years from the date of start of commercial operations ("COD") extendable by 5 (five) years.	Due to high capital investment and other practical considerations regarding cargo and logistics development etc., request a concession period of 30 years and, thereafter, option for first right of refusal.	No change, bid conditions prevail

S No	Bidder name	S No as per bidder	Page no	Article no	Text provided in document	Queries with justification (if any)	IWAI response to bidders
33	IRC	2	10	1.2.7.(e)	The Concessionaire shall pay to the Authority a cargo volume-based payment commensurate to Royalty quoted for riverine cargo as given in Article 1.2.7 (b) for the period commencing from the COD till the end of the Agreement Period or on termination whichever is earlier.	Request concessionaire to pay Royalty commencing from 4th anniversary of the COD as in the case of Multi Modal Terminal Varanasi tender.	No change, bid conditions prevail

S No	Bidder name	S No as per bidder	Page no	Article no	Text provided in document	Queries with justification (if any)	IWAI response to bidders
34	IRC	3	11	1.4.1	<p>Pre-Bid Conference :</p> <p>1.4.1 A pre-Bid conference of the interested Bidders shall be convened at the designated date, time and place. The date, time and venue of the pre-bid conference shall be:</p> <p>Date: 15 June 2020 (29 June 2020 as per Corr. 1)</p> <p>Time: 1500 hours IST</p> <p>Venue: Inland Waterways Authority of India, Head Office, Project Management Unit – 2nd Floor, A-13, Sector 1, Noida, Uttar Pradesh – 201301</p>	<p>As already requested in our e-mail dated 29.05.2020, kindly confirm your acceptance of our request for arranging video conferencing for conducting the Pre-Bid conference on <u>29th June, 2020 at 1500 hours IST</u> in view of the worsening pandemic situation and the associated restriction in travel, quarantine etc.</p>	<p>Please refer Corrigendum 3</p>

S No	Bidder name	S No as per bidder	Page no	Article no	Text provided in document	Queries with justification (if any)	IWAI response to bidders
35	IRC	4	15	2.2.1.(a).(iv)	<p>Eligibility of Bidders : Technical Capacity :</p> <p>An experience providing seaport terminal (containers, dry bulk, liquid bulk or general cargo)/ CFS/ ICD/ inland waterway terminal (containers, dry bulk, liquid bulk or general cargo) services and should have handled at least 5,372,500 (Five million three hundred seventy-two thousand and five hundred only) MT of cargo ...</p>	<p>Our experience is of handling dry bulk cargo at Haldia Dock Complex of Kolkata Port Trust which are riverine ports. So are inland waterway terminals. Therefore, handling dry bulk cargo at HDC should be accepted in terms of this clause. Kindly confirm.</p>	<p>Please refer amendment 1</p> <p>Final decision may be taken by Technical Evaluation Committee after receiving necessary documents furnishing information about project.</p>

S No	Bidder name	S No as per bidder	Page no	Article no	Text provided in document	Queries with justification (if any)	IWAI response to bidders
36	IRC	5	23	2.7.2	The draft Concession Agreement and the Feasibility Report provided by the Authority as part of the Bidding Documents shall be deemed to be part of this RFP.	Should this be submitted with all pages signed? As per Article 2.11.2, for printed and published documents, only the cover shall be initialled. Can the Draft Concession Agreement (DCA), Detailed Project Report (DPR), Environment Management Plan (EMP) be treated as printed and published documents so that signing the cover page only would suffice. Kindly confirm.	No change, bid conditions prevail.
37	IRC	6	30	3.1.1.(a)	<p>Details on Eligible Projects :</p> <p>O&M, development and construction projects in the following sectors would be considered as Eligible Projects</p> <p>(a) Inland waterway terminal (handling containers, dry bulk, break-bulk, liquid bulk or general cargo), seaport cargo terminal (handling containers, dry bulk,</p>	KoPT and Haldia are riverine ports. So are inland waterway terminals. Therefore, handling dry bulk cargo at HDC should be accepted in terms of this clause. Kindly confirm.	<p>Please refer amendment 1</p> <p>Final decision may be taken by Technical Evaluation Committee after receiving necessary documents furnishing information about project.</p>

S No	Bidder name	S No as per bidder	Page no	Article no	Text provided in document	Queries with justification (if any)	IWAI response to bidders
					breakbulk, liquid bulk or general cargo)		
38	IRC	7	30	3.1.2.(a)	For a project to qualify as an Eligible Project, following are the conditions: (a) A development project should have been undertaken as a PPP project on BOT, BOLT, BOO, BOOT or other similar basis for providing its output or services to a public sector entity or for	BOO is a public-private partnership (PPP) project model in which a private organisation builds, owns and operates some facility for a public sector entity. Our MHC project at Haldia Dock Complex (a public sector entity) is for : Supply (delivery at site, installation & commissioning), operation and maintenance of different cargo handling equipment at berth no. 13 of HDC, KoPT. Therefore, this should be treated as a development project as PPP project and	Final decision may be taken by Technical Evaluation Committee after receiving necessary documents furnishing information about project.

S No	Bidder name	S No as per bidder	Page no	Article no	Text provided in document	Queries with justification (if any)	IWAI response to bidders
					providing non-discriminatory access to users in pursuance of its charter, concession or contract, as the case may be. For the avoidance of doubt, a project which constitutes a natural monopoly such as an airport or port should normally be included in this category even if it is not based on a long-term agreement with a public entity;	on BOO basis as specified in this clause. Kindly confirm.	
39	IRC	8	30	3.1.2.(d)	The entity claiming O&M experience shall, during the last 5 (five) financial years preceding the Bid Due Date, have collected and appropriated O&M revenues from users availing of non-discriminatory access to or use of fixed project assets, such as revenues from users of	In our case, the Port collects all applicable charges including that for O&M for the cargo handling from users, who have non-discriminatory access to use our berth at the port, and passes on the cargo handling charges to us which should satisfy this clause. Kindly confirm.	Final decision may be taken by Technical Evaluation Committee after receiving necessary documents furnishing information about project.

S No	Bidder name	S No as per bidder	Page no	Article no	Text provided in document	Queries with justification (if any)	IWAI response to bidders
					airports, ports and railway infrastructure.		
40	IRC	9	34	4.5.3	The Concessionaire shall pay Royalty to the Authority for the period commencing from the COD till the end of Agreement Period or on termination whichever is earlier.	Request concessionaire to pay Royalty commencing from 4th anniversary of the COD as in the case of Multi Modal Terminal Varanasi tender.	No change, bid conditions prevail.
41	IRC	10	37	6.1	A Pre-Bid Conference of the interested parties shall be convened at the designated date, time and place. A maximum of five representatives of each Bidder shall be allowed to participate on production of authority letter from the Bidder.	Same as query given in Sl. No. 3 above.	Please refer Corrigendum 3

S No	Bidder name	S No as per bidder	Page no	Article no	Text provided in document	Queries with justification (if any)	IWAI response to bidders
42	IRC	11	38	7.3	It shall be deemed that by submitting the Bid, the Bidder agrees and releases the Authority, its employees, agents and advisors, irrevocably, unconditionally, fully and finally from any and all liability for claims, losses, damages, costs, expenses or liabilities in any way related to or arising from the exercise of any rights and/ or performance of any obligations hereunder and the Bidding Documents, pursuant hereto, and/ or in connection with the Bidding Process and waives, to the fullest extent permitted by applicable law, and waives any and all rights and/ or claims it may have in this respect,	The following should also be included in the Contract : "Consequential Damages : Notwithstanding any provision of the Contract to the contrary, neither party shall be liable to the other for any kind of special, incidental, indirect and/or consequential damages whatsoever, such as but not limited to loss of use, loss of profits, loss of production and contracts irrespective of the legal basis for any such claim."	No change, bid conditions prevail.

S No	Bidder name	S No as per bidder	Page no	Article no	Text provided in document	Queries with justification (if any)	IWAI response to bidders
					whether actual or contingent, whether present or in future.		

S No	Bidder name	S No as per bidder	Page no	Article no	Text provided in document	Queries with justification (if any)	IWAI response to bidders
43	IRC	12	42	Annexure -I Clause 30	I/ We hereby submit the following Bid for undertaking the aforesaid Project in accordance with the Bidding Documents and the Concession Agreement: I/ We offer a Royalty of INR(INR.....) in terms of INR per metric ton ("MT") of riverine cargo handled at the Terminal.	Since the Price Bid would be submitted separately, we should keep Royalty amount of INR Per MT of riverine cargo as blank. Kindly confirm.	Duly filled in Annexure I (carrying the financial bid) of RFP shall be submitted in a separate envelope and only in soft copy. It shall not be submitted as part of technical bid.
44	IRC	A1	9	1.2.7.(d)	The Concession Agreement period shall be for 10 (ten) years from the date of start of commercial operations ("COD") extendable by 5 (five) years.	Earlier we requested for 30 years concession period with option for first right of refusal thereafter. In case granting 30 years concession period is not possible, request a concession period of 15 years and, thereafter, option for first right of refusal.	No change, bid conditions prevail.

S No	Bidder name	S No as per bidder	Page no	Article no	Text provided in document	Queries with justification (if any)	IWAI response to bidders
45	IRC	A2	48	Annexure -III : Technical Capacity of the Bidder : "Note"	For conversion of US Dollars to INR, the rate of conversion shall be daily exchange rates published by the Reserve Bank of India for the Bid Due Date. In case of any other currency, the same shall first be converted to US Dollars, and the amount so derived in US Dollars shall be converted into INR at the aforesaid rate. The conversion rate of such currencies to US Dollars shall be the daily representative exchange rates published by the International Monetary Fund for the relevant date.	The Bid Due Date as per Corrigendum 3 is 11th August, 2020. Since we have to get the relevant documents certified by the statutory auditors, it may not be possible to get the RBI exchange rate up to this due date. The same is applicable for IMF exchange rate to get the Euro/USD daily. Also what is the "relevant date" for IMF exchange rate. Kindly clarify.	No change, bid conditions prevail

S No	Bidder name	S No as per bidder	Page no	Article no	Text provided in document	Queries with justification (if any)	IWAI response to bidders
46	IRC	A3	15	2.2.1	<p>In case of a Consortium, the combined technical capacity and net worth of those Members, who have and shall continue to have an equity share of at least 26% (twenty six per cent) each in the SPV, should satisfy the above conditions of eligibility, provided that each such Member shall, for a period of 4 (four) years from COD of the Project, hold equity share of not less than 26% (twenty six percent) of the subscribed and paid up equity of the SPV and 5% (five per cent) of the Total Project Cost specified in the Concession Agreement.</p>	<p>Assuming Bidder is a Consortium having 2 member companies (A) and (B) :</p> <p>Company (A) meets all the eligible criteria except adequate revenue to meet the sum of INR 118.8 crore in terms of Article 2.2.1.(a).</p> <p>Company (B) has the required revenue to make up the above shortfall except meeting the project capital cost of INR 9.50 crore in terms of Article 3.1.2.(c).</p> <p>Thus, the member companies (A) and (B) together satisfy the requirement of the "Technical Capacity" as per Articles 2.2.1 and 3.1 . We assume that the Consortium formed by member companies (A) and (B) would satisfy the above conditions of the tender. Kindly clarify.</p>	<p>Each project being furnished to demonstrate technical qualification of the bidding entity should individually satisfy all criteria for eligible projects as given in Article 3 of RFP.</p>

S No	Bidder name	S No as per bidder	Page no	Article no	Text provided in document	Queries with justification (if any)	IWAI response to bidders
47	IRC	A4	19	2.2.9	Notwithstanding anything to the contrary contained herein, in the event that the Bid Due Date falls within 6 (six) months of the closing of the latest financial year of a Bidder, it shall ignore such financial year for the purposes of its Bid and furnish all its information and certification with reference to 5 (five) years or 1 (one) year, as the case may be, preceding its latest financial year. For the avoidance of doubt, financial year shall, for the purposes of a Bid hereunder, mean the accounting year followed by the Bidder in the course of its normal business.	Can the stipulation of "Bid Due Date falls within 6 (six) months of the closing of the latest financial year of a Bidder" be amended to 3 (three) months to enable us to include performance figure of F.Y. 2019-20 into the "Technical Capacity" in terms of Article 2.9.1 (Page 24) : Amendment of RFP. Kindly clarify.	No change, bid conditions prevail

S No	Bidder name	S No as per bidder	Page no	Article no	Text provided in document	Queries with justification (if any)	IWAI response to bidders
48	IRC	A5	73	Annexure XII Item-4 Brief Description of MMT	<p>The Least Available Depth (LAD) along stretches of NW-1 are as follows:</p> <p><u>Section</u> <u>LAD(m)</u> Haldia- Barh 3.0 Barh- Ghazipur 2.5 Ghazipur-Varanasi 2.2</p>	<p>The Least Available Depth (LAD) along the stretches of NW-1 as published in River Notice of IWAI website as measured in June, 2020 in Ghazipur and Varanasi MMT are 1.2 m and 1.3 m respectively.</p> <p>We assume that necessary dredging work by the Authority is in progress. By when would the required LAD be available. Kindly clarify.</p>	<p>LAD in the channel varies seasonally. Said LAD already exists in several months every year.</p> <p>Dredging works have been initiated for stretches required and is a periodic activity.</p>
49	Five Star Logistics	1	9	1.2.7.c	<p>The Selected Bidder shall pay a Royalty ("Royalty") in terms of INR per metric ton ("MT") of Riverine Cargo ("Riverine Cargo") handled at the Terminal to the Authority ("Bid Parameter"). Additionally, for Non-Riverine Cargo ("NonRiverine Cargo") handled at the Terminal, the Selected Bidder shall pay to the Authority a</p>	<p>Considering that the cargo handling rates are widely varying, it may be difficult to quote a single Royalty on per ton basis. It may be considered to have the bidding done on Revenue Share basis in percentage. The bidder quoting highest percentage of revenue share will be the selected bidder and the selected bidder (Concessionaire) will pay on the accepted percentage on the Gross Revenue to be earned by the Concessionaire by operating the project.</p>	<p>No change, bid conditions prevail.</p>

S No	Bidder name	S No as per bidder	Page no	Article no	Text provided in document	Queries with justification (if any)	IWAI response to bidders
					royalty amounting to the Royalty quoted for Riverine cargo plus a premium of 20% (twenty percent) on Royalty quoted for Riverine cargo. For avoidance of doubt it may be clarified that Bidders shall quote a single amount for Royalty in terms of INR per MT as their Bids, however, the Concessionaire shall pay Royalty on Riverine Cargo as well as Royalty with additional premium on NonRiverine Cargo.		
50	Five Star Logistics	2	9	1.2.7.d	The Concession Agreement period shall be for 10 (ten) years from the date of start of commercial operations (“COD”) extendable by 5 (five) years.	It is requested that the Concession Agreement period be extended to 20 years with 5 years extension instead of 10 years with 5 year extension. The Successful Bidder will be expending considerable time and effort to generate and sustain traffic to the terminal. Having a longer Concession Agreement Period will allow for higher returns	No change, bid conditions prevail.

S No	Bidder name	S No as per bidder	Page no	Article no	Text provided in document	Queries with justification (if any)	IWAI response to bidders
51	Five Star Logistics	3	15	2.2.1	Alternatively, the successful bidder may be required to enter into an operation & maintenance (O&M) agreement with an entity having equivalent experience.	The Technical Capacity stipulated in 2.2.1 (a) (iv) should not be binding The successful bidder should be allowed to enter into an O & M contract post award of the contract Please clarify	No change, bid conditions prevail.

S No	Bidder name	S No as per bidder	Page no	Article no	Text provided in document	Queries with justification (if any)	IWAI response to bidders
52	Five Star Logistics	4	16	2.2.1.a	<p>Technical Capacity: For demonstrating the technical capacity and experience (“Technical Capacity”), the Bidder shall, during the past 5 (five) financial years preceding the Bid Due Date, shall have:</p> <p>(i) Collected and appropriated revenues from O&M of Eligible Projects in sectors specified in Article 3.1; and/or</p> <p>(ii) Paid for, or received payments for, construction of Eligible Projects as specified in Article 3.1; and/or</p> <p>(iii) Paid for development of Eligible Projects specified in Article 3.1</p> <p>such that the sum total of (i), (ii) and (iii) is more than INR 118.8 crore (INR One hundred and</p>	<p>The Project cost is projected at Rs47.5 Crores</p> <p>The sum of 2.2.1 (a) should be equal to the Project Cost projected Rs 47.5 Crores</p> <p>How has the figure of Rs 118.8 Cr arrived at</p>	<p>No change, bid conditions prevail.</p>

S No	Bidder name	S No as per bidder	Page no	Article no	Text provided in document	Queries with justification (if any)	IWAI response to bidders
					eighteen crore and Eighty lakh only) cumulatively during the past 5 (five) financial years; and		

S No	Bidder name	S No as per bidder	Page no	Article no	Text provided in document	Queries with justification (if any)	IWAI response to bidders
53	Five Star Logistics	5	16	2.2.1.a.iv	<p>An experience providing seaport terminal (containers, dry bulk, liquid bulk or general cargo)/ CFS/ ICD/ inland waterway terminal (containers, dry bulk, liquid bulk or general cargo) services and should have handled at least 5,372,500 (Five million three hundred seventy-two thousand and five hundred only) MT of cargo or 358,167 (Three hundred fifty-eight thousand one hundred and sixty seven only) Twenty Foot Equivalent Units ("TEUs") cumulatively during the past 5 (five) financial years. For calculation purpose, the conversion rate of 1TEU=15 MT shall be used.</p>	<p>Please also include "Riverine" Terminal as well along with Seaport Terminals</p> <p>5,372,500 (Five million three hundred seventy-two thousand and five hundred only) MT of cargo or 358,167 (Three hundred fifty-eight thousand one hundred and sixty seven only) Twenty Foot Equivalent Units ("TEUs") cumulatively during the past 5 (five) financial years. For calculation purpose, the conversion rate of 1TEU=15 MT shall be used.</p> <p>Please explain how this figure has been arrived at</p>	<p>Please refer amendment 1</p> <p>Please refer annexure 8</p>

S No	Bidder name	S No as per bidder	Page no	Article no	Text provided in document	Queries with justification (if any)	IWAI response to bidders
54	Five Star Logistics	6	17	2.2.1	The Consortium may include a member with at least ten per cent equity participation and having relevant experience in operation and maintenance (O&M). Alternatively, the successful bidder may be required to enter into an operation & maintenance (O&M) agreement with an entity having equivalent experience.	Please clarify what is meant by "relevant experience"	Please refer Articles 2 and 3 of RFP.
55	Five Star Logistics	7	19	2.2.8	then the selection of such foreign Bidder or in the event described in sub Article (b) above, the selection of the Bidder shall be subject to approval of the Authority from national security and public interest perspective. The decision of the Authority in this behalf shall be	Please clarify that no "Security Clearance" is required for Indian Entities who are not coming under Clause 2.2.8	Security clearances shall be conducted as per Applicable Law

S No	Bidder name	S No as per bidder	Page no	Article no	Text provided in document	Queries with justification (if any)	IWAI response to bidders
					conclusive and binding on the Bidder.		

S No	Bidder name	S No as per bidder	Page no	Article no	Text provided in document	Queries with justification (if any)	IWAI response to bidders
56	OSL	1	8	1.2.1	<p>The Authority has adopted a single-stage bidding process (referred to as the “Bidding Process”) for selection of the Bidder for award of the Project as given in Article 1.1.4 of this document.</p> <p>The Government of India has issued guidelines (see Annexure XI-of RFP) for qualification of Bidders seeking to acquire stakes in any public sector enterprise through the process of disinvestment. These guidelines shall apply mutatis mutandis to this Bidding Process. The Authority shall be entitled to disqualify a Bidder in accordance with the aforesaid guidelines at any stage of the Bidding Process. Bidders must satisfy</p>	Kindly Elaborate on disqualification guidelines.	Please refer Articles 2 and 3 of RFP.

S No	Bidder name	S No as per bidder	Page no	Article no	Text provided in document	Queries with justification (if any)	IWAI response to bidders
					themselves that they are qualified to bid, and should give an undertaking to this effect in the form at Annexure I		

57	OSL	2	9	1.2.7 (b)	<p>The Selected Bidder shall pay a Royalty (“Royalty”) in terms of INR per metric ton (“MT”) of Riverine Cargo (“Riverine Cargo”) handled at the Terminal to the Authority (“Bid Parameter”).</p> <p>Additionally, for Non-Riverine Cargo (“Non-Riverine Cargo”) handled at the Terminal, the Selected Bidder shall pay to the Authority a royalty amounting to the Royalty quoted for Riverine cargo plus a premium of 20% (twenty percent) on Royalty quoted for Riverine cargo.</p> <p>For avoidance of doubt it may be clarified that Bidders shall quote a single amount for Royalty in terms of INR per MT as their Bids, however, the Concessionaire shall pay Royalty on Riverine Cargo as well as Royalty with additional premium on Non-Riverine Cargo.</p>	<p>Kindly provide adopted policies considered for categorization of Riverine and Non-riverine Cargo and the basis for levying additional premium of 20% Royalty on Non-Riverine Cargo.</p> <p>Non-riverine cargo , this term is not very clear as it is not used in the marine industry in India, please clarify with an example.</p>	<p>Please refer Article 1 of Draft Concession Agreement for definitions</p>
----	-----	---	---	------------------	-----------------------------------------------------------------------------------------------------------------------------------------------------------------------------------------------------------------------------------------------------------------------------------------------------------------------------------------------------------------------------------------------------------------------------------------------------------------------------------------------------------------------------------------------------------------------------------------------------------------------------------------------------------------------------------------------------------------------------------------------------------------------	-----------------------------------------------------------------------------------------------------------------------------------------------------------------------------------------------------------------------------------------------------------------------------------------------------------------------------------------------------	-----------------------------------------------------------------------------

S No	Bidder name	S No as per bidder	Page no	Article no	Text provided in document	Queries with justification (if any)	IWAI response to bidders
58	OSL	3	10	1.2.7 (e)	The Concessionaire shall pay to the Authority a cargo volume-based payment commensurate to Royalty quoted for riverine cargo as given in Article 1.2.7 (b) for the period commencing from the COD till the end of the Agreement Period or on termination whichever is earlier.	Is any MGT prescribed or formulated for considering while bidding including the basis thereof ?	Please refer Article 7 of Draft Concession Agreement
59	OSL	4	10	1.2.9	The Concessionaire shall, in consideration of its investment and services, be entitled to levy and recover Tariff from the users of the Project Facilities and Services.	Is there any pre-approved Tariff prescribed with provisions of escalation if any?	Please refer Article 8 and Annexure XIV of Draft Concession Agreement
60	OSL	5	10	1.3	Pre-Bid conference on 15 June 2020	Looking into ongoing global pandemic / Lockdown, shall the pre-bid conference be postponed ?	Please refer Corrigendum 3

61	OSL	-	7	1.1.1	<p>The Inland Waterways Authority of India (“Authority”) is engaged in the development of Multimodal Terminal located at Haldia in the state of West Bengal (the “Terminal”). The estimated project cost (“Estimated Project Cost”) of the Project at the Terminal is approximately INR 47.5 crore (INR Forty seven crore and fifty lakh only). Additionally, the Authority is investing approximately INR 452.2 crore (INR Four hundred fifty two crore and twenty lakh only) and is expected to invest approximately INR 19 crore (INR Nineteen crore only) on railway connectivity</p>	<p>Kinldy clarify if there are any additional charges to be paid. Who shall provide the Engine for shutting etc. Will royalty be applicable.</p>	<p>Concessionaire shall be responsible for expenses as per provisions of the Draft Concession Agreement</p>
----	-----	---	---	-------	-------------------------------------------------------------------------------------------------------------------------------------------------------------------------------------------------------------------------------------------------------------------------------------------------------------------------------------------------------------------------------------------------------------------------------------------------------------------------------------------------------------------------------------------------------------------------------------------	--------------------------------------------------------------------------------------------------------------------------------------------------	-------------------------------------------------------------------------------------------------------------

S No	Bidder name	S No as per bidder	Page no	Article no	Text provided in document	Queries with justification (if any)	IWAI response to bidders
62	OSL	9	7	1.1.2	he Authority has decided to engage an entity ("Concessionaire") to equip, operate and transfer the Terminal on 'Equip, Operate and Transfer' ("EOT") basis. These and other allied activities shall be referred to as the ("the Project")	Bidders need to know the details for bid preparation and quote competitively Kindly define 'other allied activities'	Please refer Annexure III of Draft Concession Agreement
63	OSL	10	15	2.2.2(a)	In case a particular job/contract has been executed by the Bidder (as part of a Consortium), it should further support its claim for the share in work done for that particular job/contract by producing a certificate from its statutory auditor or client, and	In case the bidder has experience in development of Eligible Projects specified in Article 3.1 as part of a Consortium, can the Bidder claim the revenue earned/appropriated as well as volume handled to the extent of its shareholding in the Eligible Project ? Can this be applied to 2.2.2 (b) and (c) ?	The same project may be quoted to establish experience for O&M revenue and cargo volume handled.

S No	Bidder name	S No as per bidder	Page no	Article no	Text provided in document	Queries with justification (if any)	IWAI response to bidders
64	OSL	11	18	2.2.7(d)	In case the Bidder is a Consortium, each Member should substantially satisfy the qualification requirements to the extent specified herein.	For enabling selection of right entity as member in the Consortium Kindly quantify the words 'substantially satisfy'	Submitting all necessary information to support technical and financial bids shall be responsibility of bidders.

65	SAPL	1	15	2.2	<p>2.2 Eligibility of Bidders</p> <p>2.2.1 To be eligible for qualification, a Bidder shall fulfil the following conditions of eligibility:</p> <p>(a) Technical Capacity: For demonstrating the technical capacity and experience (“Technical Capacity”), the Bidder shall, during the past 5 (five) financial years preceding the Bid Due Date, shall have:</p> <p>(i) Collected and appropriated revenues from O&M of Eligible Projects in sectors specified in Article 3.1; and/or</p> <p>(ii) Paid for, or received payments for, construction of Eligible Projects as specified in Article 3.1; and/or</p> <p>(iii) Paid for development of Eligible Projects specified in Article 3.1 such that the sum total of (i), (ii) and (iii) is more than INR 118.8 crore (INR One hundred and eighteen crore and Eighty lakh</p>	<p>Background</p> <p>As per Finance Act, 2015 (Act. No. X) published through Bangladesh Gazette dated June 30, 2015, it has now become mandatory for the taxpayer companies in Bangladesh to maintain a uniform income year beginning on 1st July and ending, after expiry of 12 months period, on 30th June of the following Gregorian calendar year. In compliance with the change promulgated in the Finance Act 2015, the taxpayer companies have to follow the uniform income year effective from July 01, 2016. But before that, the taxpayer companies of Bangladesh had the liberty to choose their financial year according to their operational convenience and Summit Alliance Port Limited (hereinafter referred to as ‘SAPL’) used to follow January-December as its Income year. Accordingly until 2015 SAPL’s financial year was January-December, but after the promulgation of the change as stated above in conjunction with guideline notified by the Bangladesh Securities and Exchange Commission (BSEC) as published on April 27, 2016, we, as a Publicly Listed Company, had to change our Income Year as well and for the first year, Income year was extended for 18 (eighteen) months ended on 30th June 2017 which was then audited, authenticated by the Board and approved by the Shareholders of the Company in the relevant AGM after the</p>	<p>Financial year will be considered as per Applicable Law for the relevant applicant.</p> <p>Final decision may be taken by Technical Evaluation Committee after receiving necessary documents furnishing information.</p>
----	------	---	----	-----	--------------------------------------------------------------------------------------------------------------------------------------------------------------------------------------------------------------------------------------------------------------------------------------------------------------------------------------------------------------------------------------------------------------------------------------------------------------------------------------------------------------------------------------------------------------------------------------------------------------------------------------------------------------------------------------------------------------------------------------------------------------------------------------------------------------------------------------	------------------------------------------------------------------------------------------------------------------------------------------------------------------------------------------------------------------------------------------------------------------------------------------------------------------------------------------------------------------------------------------------------------------------------------------------------------------------------------------------------------------------------------------------------------------------------------------------------------------------------------------------------------------------------------------------------------------------------------------------------------------------------------------------------------------------------------------------------------------------------------------------------------------------------------------------------------------------------------------------------------------------------------------------------------------------------------------------------------------------------------------------------------------------------------------------------------------------------------------------------------------------------------------------------------------------------------------------------------------------------	-----------------------------------------------------------------------------------------------------------------------------------------------------------------------------------------------------------------------------

				<p>only) cumulatively during the past 5 (five) financial years; and</p> <p>(iv) An experience providing seaport terminal (containers, dry bulk, liquid bulk or general cargo)/ CFS/ ICD/ inland waterway terminal (containers, dry bulk, liquid bulk or general cargo) services and should have handled at least 5,372,500 (Five million three hundred seventy-two thousand and five hundred only) MT of cargo or 358,167 (Three hundred fifty-eight thousand one hundred and sixty seven only) Twenty Foot Equivalent Units ("TEUs") cumulatively during the past 5 (five) financial years. For calculation purpose, the conversion rate of 1TEU=15 MT shall be used.</p> <p>(b) Financial Capacity: The Bidder shall have a minimum Net Worth ("Financial Capacity") of</p>	<p>closing of the new financial year. Therefore, for the last 5 years, our audited Financials Statements were prepared for the Income year as shown the table below (started with the latest audited financial year):</p> <p>+J46</p> <p>Query</p> <p>In view of the facts stated above, in filling up the tender schedules, Audited figures/ data for the last five income years comprise of 66 months' Accounts as explained in the Table above. Hope this presentation, complying with the changes made by the Country's regulators, will meet your requirement.</p> <p>In the event you are of a different view we shall be obliged to have your kind guidance to enlighten us as to how we shall calculate past 5 years data to meet the tender requirement i.e. how many months we will consider while calculating past 5 years data.</p> <p>We can however prepare 2014-15, 2015-16 and 2016-17 (all with 12 month period of Income year) but that will be prepared based on our accounting records but not audited.</p>	
--	--	--	--	-------------------------------------------------------------------------------------------------------------------------------------------------------------------------------------------------------------------------------------------------------------------------------------------------------------------------------------------------------------------------------------------------------------------------------------------------------------------------------------------------------------------------------------------------------------------------------------------------------------------------------------------------------------------------------------------------------------------------------------------------------------------------------	---------------------------------------------------------------------------------------------------------------------------------------------------------------------------------------------------------------------------------------------------------------------------------------------------------------------------------------------------------------------------------------------------------------------------------------------------------------------------------------------------------------------------------------------------------------------------------------------------------------------------------------------------------------------------------------------------------------------------------------------------------------------------------------------------------------------------------------------------------------------------------------------------------------------------------------------------------------------------------------------------------------------------------	--

				<p>INR 23.8 crore (INR Twenty three crore and eighty lakh only) at the close of the financial year immediately preceding the Bid Due Date.</p> <p>In case of a Consortium, the combined technical capacity and net worth of those Members, who have and shall continue to have an equity share of at least 26% (twenty six per cent) each in the SPV, should satisfy the above conditions of eligibility, provided that each such Member shall, for a period of 4 (four) years from COD of the Project, hold equity share of not less than 26% (twenty six percent) of the subscribed and paid up equity of the SPV and 5% (five per cent) of the Total Project Cost specified in the Concession Agreement.</p> <p>The Consortium may include a member with</p>		
--	--	--	--	-----------------------------------------------------------------------------------------------------------------------------------------------------------------------------------------------------------------------------------------------------------------------------------------------------------------------------------------------------------------------------------------------------------------------------------------------------------------------------------------------------------------------------------------------------------------------------------------------------------------------------------------------------------------------------------------------------------------------------------------------------------------	--	--

					<p>at least ten per cent equity participation and having relevant experience in operation and maintenance (O&M). Alternatively, the successful bidder may be required to enter into an operation & maintenance (O&M) agreement with an entity having equivalent experience.</p>		
--	--	--	--	--	---------------------------------------------------------------------------------------------------------------------------------------------------------------------------------------------------------------------------------------------------------------------------------------------	--	--

S No	Bidder name	S No as per bidder	Page no	Article no	Text provided in document	Queries with justification (if any)	IWAI response to bidders
66	Ripley	1	1.3	Schedule of Bidding Process		<p>It is requested to extend the date of pre bid conference at Noida considering the present pandemic situation due to COVID-19.</p> <p>Kindly revised the date of Pre Bid Conference and Bid Due date.</p>	Please refer Corrigendum 3

S No	Bidder name	S No as per bidder	Page no	Article no	Text provided in document	Queries with justification (if any)	IWAI response to bidders
67	Ripley	2	1.2.7	Royalty		<p>The Selected Bidder shall pay a Royalty ("Royalty") in terms of INR per metric ton ("MT") of Riverine Cargo. Additionally, for Non-Riverine Cargo handled at the Terminal, the Selected Bidder shall pay to the Authority a royalty amounting to the Royalty quoted for Riverine cargo plus a premium of 20% (twenty percent) on Royalty quoted for Riverine cargo.</p> <p>It may be submitted that there are various types of cargo to be handled at the Terminal with different tariff.</p> <p>The Royalty in terms of INR per metric ton (MT) may be reviewed.</p> <p>It may also request to reduce the premium percentage from 20 % to 10 %.</p>	No change, bid conditions prevail

S No	Bidder name	S No as per bidder	Page no	Article no	Text provided in document	Queries with justification (if any)	IWAI response to bidders
68	Bothra Group	1	-	-	-	Bidding process be deferred by 2 months	Please refer corrigenda regarding extension of bid schedule
69	HIPL	AA5	16	2.2.2	It was stated in the pre bid meeting held on July 10,2020 that if Bidder submits certificates from more than one Auditor Certificate towards requirement as per Clause 2.2.2 of the RFP, the bidder would be required to provide letter providing explanation.	Authority requested to provide the format(if any) of such letter. Further, please confirm that such a letter would form part of Annexure V	The undertaking may be provided in appropriate format by bidder

S No	Bidder name	S No as per bidder	Page no	Article no	Text provided in document	Queries with justification (if any)	IWAI response to bidders
70	ICT	1			Clause 1.1.1 (Page No. 8) The Estimated Project Cost ("Project Cost") of the terminal is approximately Rs.47.5 Crore	It is requested to share the detailed break-up of estimated project cost	Please refer Annexure 1 (to this document)
71	ICT	2			Clause 1.2.7 (d) (Page No. 9) The Concession Agreement period shall be for 10 (ten) years from the date of start of commercial operations ("COD") extendable by 5 (five) years.	<ul style="list-style-type: none"> · Terminal requires to be equipped with specialized equipment which cannot be recovered fully within 10 years. Typical debt period for the said equipment varies from 8-10 years. · Thus, it is not possible to fully utilize, depreciate and earn a decent return on capital within 10 years with 5 years extension. In lieu of this, we request for "The Concession Agreement period shall be for 15 (fifteen) years from the date of start of commercial operations ("COD") extendable by 5 (five) years" 	This is as per appraisal and approval of SFC.

S No	Bidder name	S No as per bidder	Page no	Article no	Text provided in document	Queries with justification (if any)	IWAI response to bidders
72	ICT	3			<p>Clause 2.5.1 (Page No. 20) Site visit and verification of information The Bidders are encouraged to submit their respective Bids after visiting the Project site and ascertaining for themselves the site conditions, traffic, location, surroundings, climate, availability of power, water and other utilities for construction, access to site, handling and storage of materials, weather data, applicable laws and regulations, and any other matter considered relevant by them.</p>	<ul style="list-style-type: none"> · In view of the COVID-19 travel restrictions, we may not be able to make the site visits for the technical evaluation. · It is requested that the detailed specifications of the terminal equipment to be furnished to us include type, make, standard, brochures, technical specifications, maintenance schedule, warranty period, defect liability period etc. · Apart from above, other details like status of the connectivity (Road & Rail), backup area, draft available at berths and channel may also be provided 	Please refer corrigenda regarding extension of bid schedule

S No	Bidder name	S No as per bidder	Page no	Article no	Text provided in document	Queries with justification (if any)	IWAI response to bidders
73	ICT	4			Annexure XII (Page 72) Brief Description of Multimodal Terminal at Haldia	<ul style="list-style-type: none"> · As per the RFP, it is mentioned as 2 nos. whereas, 25. · Annexure III: Scope of Work on Page 100 of the DCA it is stated as 1 nos. Please clarify, the number of MHC/ MHC's required to be deployed by the Concessionaire 	Please refer amendment 9
74	ICT	5			Clause 2.13 (Page 26) Bid Due Date	<ul style="list-style-type: none"> · In view of the present conditions of COVID-19, it is requested to extend the bid due date by 2 months after replies to pre-bid queries. 	Please refer corrigenda regarding extension of bid schedule
75	AM Enterprises				-	<ol style="list-style-type: none"> 1. Can a successful bidder (single company) or consortium(say consisting of 2 member companies) add a JV partner at a later date, after being awarded the LOA, from a financial(investor)/ O&M experience perspective? 2. If the previous question (question 1) is in affirmative, then how is the partner added? 	Response to this query shall be shared in second set of responses to pre-bid queries.

76	IRC		48	Annexure III : Note	<p>\$\$ For conversion of US Dollars to INR, the rate of conversion shall be daily exchange rates published by the Reserve Bank of India for the Bid Due Date. In case of any other currency, the same shall first be converted to US Dollars, and the amount so derived in US Dollars shall be converted into INR at the aforesaid rate. The conversion rate of such currencies to US Dollars shall be the daily representative exchange rates published by the International Monetary Fund for the relevant date.</p>	<p>On the Bid Due Date, as per Article 2.13 of the RFP, we have to upload the Bid before 1500 hours IST.</p> <p>We had imported our project materials from Germany and paid for the same in Euro calling for two conversions; Euro/USD and USD/INR. As per Note of Annexure III under reference, we have to collect USD/INR as well as Euro/USD conversion rates from RBI and IMF respectively in the morning of Bid Due Date. The above situation gives the bidder practically two hours time in the morning of Bid Due Date to collect the rates from RBI/IMF, complete filling up item 5 of Annexure V based on the collected conversion rates and then get it certified from the statutory auditor and then upload the documents. Considering the limited time available, this would be extremely difficult if not impossible.</p> <p>To ascertain the eligibility of a development project in terms of minimum capital cost, the same Note given in a recent tender of Syama Prasad Mookerjee Port (SMP), reads as follows :</p> <p>"\$\$ For conversion of US Dollars to Rupees, the rate of conversion shall be Rupees 75.97 (Rupees Seventy-Five & Ninety-Seven Paisa) to a US Dollar. In case of any other currency, the same shall first</p>	Please refer amendment no 14
----	-----	--	----	---------------------	-------------------------------------------------------------------------------------------------------------------------------------------------------------------------------------------------------------------------------------------------------------------------------------------------------------------------------------------------------------------------------------------------------------------------------------------------------------------------------------------------------------------------	------------------------------------------------------------------------------------------------------------------------------------------------------------------------------------------------------------------------------------------------------------------------------------------------------------------------------------------------------------------------------------------------------------------------------------------------------------------------------------------------------------------------------------------------------------------------------------------------------------------------------------------------------------------------------------------------------------------------------------------------------------------------------------------------------------------------------------------------------------------------------------------------------------------------------------------------------------------------------------------------------------------------------------------------------------------------------------------------------------------------------------------------------------------------------------------------------------------------------------------------------------	------------------------------

					<p>be converted to US Dollars as on the date 60 (sixty) days prior to the Application Due Date, and the amount so derived in US Dollars shall be converted into Rupees at the aforesaid rate. The conversion rate of such currencies shall be the daily representative exchange rates published by the International Monetary Fund for the relevant date. "</p> <p>We request a similar model for this Note to facilitate submission of Bid by the bidders having imported equipment in their eligible project. Kindly confirm.</p>	
--	--	--	--	--	-------------------------------------------------------------------------------------------------------------------------------------------------------------------------------------------------------------------------------------------------------------------------------------------------------------------------------------------------------------------------------------------------------------------------------------------------------------------------------------------------------------------------------------	--

Queries regarding DCA

S No	Bidder name	S No as per bidder	Page no	Article no	Text provided in document	Queries with justification (if any)	IWAI response to bidders
1	Adani Logistics	12	11	1.1	<p>“Total Project Cost” means the lowest of –</p> <p>(a) The capital cost of the Project for Concessionaire as set forth in the Financial Package including capital cost incurred by Concessionaire for development/equipment of Terminal infrastructure</p> <p>(b) The actual capital cost of the Project for Concessionaire upon completion including capital cost incurred by Concessionaire for development/equipment of Terminal infrastructure</p> <p>(c) A sum of INR 47.5 crore (INR Forty-seven crore and fifty lakh) only</p>	<p>It appears to be a typo, it should be the “highest” (not the lowest) of the three elements mentioned.</p> <p>‘Total Project Cost’ may increase due to reasons beyond the Concessionaire control. Considering that the financial risk is carried by the Concessionaire, the “lowest” is not acceptable.</p>	No change, bid conditions prevail

S No	Bidder name	S No as per bidder	Page no	Article no	Text provided in document	Queries with justification (if any)	IWAI response to bidders
2	Adani Logistics	13	19	3.1.2 (b) 6.4.4	Obtaining "Applicable Permits" as may be required for commencement of Expansion Phase as set out in Annexure XIII. Obtain Applicable Permits, comply with Applicable Laws and Applicable Permits and give priority to safety in its development/ equipment and planning activities in order to protect life, health, property and environment;	Obtaining Environment Clearance, Approval from Central Empowered Committee constituted by the Supreme Court for the Terminal and Forest Clearance shall be the responsibility of the Concessing Authority. Kindly confirm.	No change, bid conditions prevail
3	Adani Logistics	14	31	5	Independent Engineer and Independent Surveyor	Concessionaire is responsible for the operations, maintenance, management and development of the terminal and in no	No change, bid conditions prevail

S No	Bidder name	S No as per bidder	Page no	Article no	Text provided in document	Queries with justification (if any)	IWAI response to bidders
4	Adani Logistics	15	110	Annex. V 3.	Role and functions of the Independent Surveyor	case shall be responsible for the unsuccessful passage of the vessels through the channel.	No change, bid conditions prevail
5	Adani Logistics	16	31	5.6 (a) & (b)	(a) Concessionaire has taken an informed decision about the size of the vessel and volume of cargo that can pass through the waterway by checking the LAD information updated weekly by the Authority on their website or any other source of information used in the future. (b) Concessionaire has adhered to the waterway channel as declared by the Authority in their navigational charts updated periodically.	Suggested Amendments: "Article 5: Independent Engineer" "Article 5.6: Deleted" "Annexure V: Terms of Reference for Independent Engineer" "Annexure V point 3 : Deleted"	No change, bid conditions prevail

S No	Bidder name	S No as per bidder	Page no	Article no	Text provided in document	Queries with justification (if any)	IWAI response to bidders
6	Adani Logistics	17	28	6.7.3 6.7.4	Annexure XI	It shall be Annexure XII	Please refer amendments 7 and 8
7	Adani Logistics	18	127	Annex VIII, 4.4.1	(a) removal of disabled vessel from channel; (c) vessel accidents in and around the vicinity of the Terminal;	Please provide us a map of the terminal representing its water limits and the length, width and hydrostatic data of the concerned channel within the ambit of this Clause. Also, please clarify whether there is any wreck or any unseen obstruction below the water which can restrict safe access of vessels to the Haldia MMT.	Please refer Annexure 2 (of this document)
8	Adani Logistics	19	35	7.1.9 7.3.4	The Concessionaire shall install, operate and maintain such computer system and network (such as Electronic Data Interchange and Terminal Community System) and follow such protocol as the Concessioning	Please suggest who will be responsible for developing this – Concessionaire or Concessioning Authority	Concessioning Authority shall be responsible for development of Terminal Community System All other responsibilities in this regard shall be of Concessionaire

S No	Bidder name	S No as per bidder	Page no	Article no	Text provided in document	Queries with justification (if any)	IWAI response to bidders
					<p>Authority may specify from time to time. The Terminal Community System would be developed by the Concessions Authority.</p>		
9	Adani Logistics	20	35	7.1.12 (a)	Minimum Guaranteed Cargo	<p>As you appreciate, any Concessionaire need some time to get acquainted with the system, its operating standards and training of manpower. The MGT clause shall be exempted for the first three anniversaries and should be applicable from the 4th year of operations. Please include non-riverine cargo also for calculation of the MGT.</p>	No change, bid conditions prevail

S No	Bidder name	S No as per bidder	Page no	Article no	Text provided in document	Queries with justification (if any)	IWAI response to bidders
10	Adani Logistics	21	42	9.2.1	All such payments shall be exclusive of applicable taxes which the Concessionaire will pay over and above Royalty payments.	Please define the taxes applicable on Royalty Payments	Bidders may self-evaluate taxes applicable
11	Adani Logistics	22	42	9.2.3	Royalty for each month shall be paid on or before the 7th (seventh) day of the following month.	We understand that the Concessionaire shall pay the Royalty on actual cargo handled Vs minimum monthly guarantee whichever is higher. In few months, Actual cargo handled may be lesser than the monthly minimum guarantee and vice versa. There is a possibility that the payments made as Royalty is more than the actual dues. Please add a provision that the Minimum Guaranteed and Actual Cargo handled by the Concessionaire shall be reconciled on half	No change, bid conditions prevail

S No	Bidder name	S No as per bidder	Page no	Article no	Text provided in document	Queries with justification (if any)	IWAI response to bidders
						yearly basis for issuance of the credit note.	
12	Adani Logistics	20	31	Article 6.9	Liquidated Damages	To be equitable, the provision regarding Liquidated Damages shall be made applicable also to the Concessioneing Authority in case of failure to fulfil its obligations under the Concession Agreement.	No change, bid conditions prevail

S No	Bidder name	S No as per bidder	Page no	Article no	Text provided in document	Queries with justification (if any)	IWAI response to bidders
13	Adani Logistics	21	38	Article 7.2.2	Liability for draft maintenance along NW-1	The liability of the Concessioning Authority for draft maintenance shall be independent of the Concessionaire's commitment to meet MGT. In any case, the MGT should be reduced proportionately.	No change, bid conditions prevail
14	Adani Logistics	22	100	Annex III	Scope of Work	Please clarify the number of MHC (s) required to be deployed by the Concessionaire. As per Annexure XII: Brief Description of Multimodal Terminal at Haldia of the RFP, it is mentioned as 2 nos. whereas, 25. Annexure III: Scope of Work on Page 100 of the DCA it is stated as 1 nos.	Please refer Annexure I (of this document) Please refer Annexure III (of Draft Concession Agreement) Please refer amendment 9
15	Adani Logistics	23	Page 153 of Bid Documents	Annexure 1	Project Site	Besides the CAD drawing, a brief description of the project site may please be incorporated mentioning inter- alia the	Please refer Annexure 3 (of this document)

S No	Bidder name	S No as per bidder	Page no	Article no	Text provided in document	Queries with justification (if any)	IWAI response to bidders
						approximate area of land being handed over.	
16	Adani Logistics	24	158	Annexure IV	Performance Standards	The Key Performance Indicators 1 & 2 should be related to 'Total Available Hours' and NOT to Total Deployed Hours. Alternatively, it may be clarified that the 'Total Deployed Hours' includes idle time of equipment for want of requirements by / demand from users.	Please refer amendment 12
17	Adani Logistics	25	158 - 159	Annexure IV	Performance Standards	It is our understanding that the Key Performance Indicators 3 & 4 relate only to ship-to-shore handling of containers and cargo. Kindly confirm.	These KPIs pertain to water-side productivity

S No	Bidder name	S No as per bidder	Page no	Article no	Text provided in document	Queries with justification (if any)	IWAI response to bidders
18	Adani Logistics	26	159	Annexure IV	Performance Standard at Sl. No.5 – Average turnaround time of trucks	The Average turnaround time of 120 minutes may be specified only in respect of container trucks. For trucks carrying bulk, break-bulk and bagged cargoes, the average turnaround time will have to be much higher. Moreover, this performance standard may be related only to trucks moving riverine cargo.	Please refer amendment 11
19	HIPL	19	7		THIS CONCESSION AGREEMENT is made at _____ on the _____ day of _____ BETWEEN:	Authority has used the term "Equip, Operate and Transfer Agreement" on first page of Agreement . It is presumed that the two terms "Equip, Operate and Transfer Agreement" and "Concession Agreement" means the same and are used interchangeably. Please confirm.	Confirmed

S No	Bidder name	S No as per bidder	Page no	Article no	Text provided in document	Queries with justification (if any)	IWAI response to bidders
20	HIPL	20	12	1.1	Debt Due : all accrued interest, financing fees and charges payable on or in respect of the debt referred to in sub-article (a) above upto the Transfer Date but excluding (i) any interest, fees or charges that had fallen due one year prior to the Transfer Date, and (and (ii) penal interest or charges, payable under the Financing Documents to any Senior Lender.	Authority should consider exclusion of all accrued interest, financing fees and charges that had fallen due six month prior to the Transfer Date. This is as per the standards adopted in Model Concession Agreement	No change, bid conditions prevail
21	HIPL	21	17	1.1	Project Site” means the area demarcated in Annexure I including the waterfront (which shall include adjacent channel stretch of 700 meters on both sides of terminal from center point at coordinates 22o 03' 38" N and 88o 08' 26" E) existing berth, land together	Please provide the to-scale AUTO CAD drawing, layout and coordinates of the Project Site along with details of boundary demarcation and location of items under Terminal's Assets. We understand that the pdf format of layout and boundary has been provided (I-525/	Please refer Annexure 2 (of this document)

S No	Bidder name	S No as per bidder	Page no	Article no	Text provided in document	Queries with justification (if any)	IWAI response to bidders
					with buildings, structures if any.....	HT/ 204 and I-525/HT/233)	
22	HIPL	22	16	1.1	“Project” means the design, finance, construction, operation, maintenance, and marketing and providing of the Project Facilities and Services at Multimodal Terminal at Haldia, West Bengal, India; in accordance with the provisions of this Agreement.	<ol style="list-style-type: none"> 1. Please define the term Project Facilities and Services. 2. Please confirm that the responsibility of design , finance and construction for the Terminal's Assets (as defined in Article 24:Annexure II) is not the responsibility of the Concessionaire and hence the same may be specifically mentioned in the definition of Project 	<ol style="list-style-type: none"> 1. Please refer Article 1.1 of DCA 2. Concessionaire shall be responsible for operation, maintenance and management of Terminals's Assets as per Articles 2.4 and 6.4

S No	Bidder name	S No as per bidder	Page no	Article no	Text provided in document	Queries with justification (if any)	IWA response to bidders
23	HIPL	23	17	1.1	<p>“Project Facilities and Services” means the facilities and services as set out under the Scope of Work, to be provided by the Concessionaire during the Concession Period, in accordance with this Agreement.</p>	<p>The Annexure III Scope of Work does not explicitly define the term "Project Facilities and Services". Authority may please advise on the definition of Project Facilities and Services in the context of Terminal, Terminal's Assets and Terminal Equipment Phase</p>	<p>Please refer Article 1.1 of Draft Concession Agreement</p> <p>Please refer Annexure 1 (of this document)</p> <p>Please refer Annexure III (of Draft Concession Agreement)</p>

S No	Bidder name	S No as per bidder	Page no	Article no	Text provided in document	Queries with justification (if any)	IWAI response to bidders
24	HIPL	24	19	1.1	Total Project Cost means the lowest of	<p>1. The Total Project Cost should be considered as the highest instead of lowest of (a), (b) and (c) in order to consider the case when actual cost exceeds the one set forth in the Financial Package and the estimated cost of INR 47.5 cr. Authority requested to modify the clause accordingly.</p> <p>2. It is stated that as estimated by the Concessing Authority the Project Cost is INR 47.5 cr. Authority to provide the breakup of sum of INR 47.5 cr and baseline year of its estimation.</p> <p>3. Authority to advise on what is implied by "development/equipment of Terminal infrastructure"</p>	<p>1. No change, bid conditions prevail</p> <p>2. Please refer Annexure 1 (of this document)</p> <p>3. Please refer Article 1.1 of DCA</p> <p>4. Please refer Annexure 1 (of this document)</p> <p>5. Please refer base cost data given in the DPR</p>

S No	Bidder name	S No as per bidder	Page no	Article no	Text provided in document	Queries with justification (if any)	IWAI response to bidders
						5. Authority requested to provide the baseline data and report based on which the total cost of INR 47.5 cr has been estimated for the project.	

S No	Bidder name	S No as per bidder	Page no	Article no	Text provided in document	Queries with justification (if any)	IWA response to bidders
25	HIPL	25	24	2.4.2	The Concessionaire shall at its costs, charges and expenses make such development and improvements in the Project Site and Terminal's Assets as may be necessary or appropriate for implementing the Project and providing Project Facilities and Services in accordance with the Agreement, Applicable Laws and Applicable Permits.	Authority may clarify that apart from the Scope of Works what other development and improvements works by Concessionaire are foreseen for the Project Site and Terminal Assets.	Concessionaire shall fulfill its development, maintenance and management obligations as per provision of the DCA

S No	Bidder name	S No as per bidder	Page no	Article no	Text provided in document	Queries with justification (if any)	IWAI response to bidders
26	HIPL	26	25	2.7.1	Acceptance of the Project Site and Terminal's Assets	<p>1. Authority to confirm that a joint site inspection would be conducted and the following be carried out by the Concessioneing Authority before Concessionaire accepts the possession of Project Site and Terminal's Assets</p> <p>1. Rectification of all equipment basis the outcome of the joint inspection to restore them in good order acceptable to the Concessionaire</p> <p>2. Provide all equipment warranties</p> <p>3. Provide list and details of all spares to be provided as part of Terminal's Assets</p> <p>4. Confirm that any third party shall vacate and there shall be no claims of employees of any third party</p>	<p>1 & 2) Please refer Amendment 5</p> <p>3 & 4) Details shall be shared with successful bidder</p> <p>5) Please refer Article 2.8 of Draft Concession Agreement</p>

27	HIPL	27	27	3.1.2 (b)	<p>Obtaining “Applicable Permits” as may be required for commencement of Terminal Equipmnt Phase as set out in Annexure XIII.</p>	<p>1. It may be noted that obtaining Applicable permits, as listed in Annexure XIII, should be the responsibility of the Concessioneing Authority.</p> <p>2. While Article 3.1.2 refers to Applicable Permits as set out in Annexure III as CP to be fulfilled by the Concessionaire, Article 3.2.1 refers to the same Annexure III as CP to be fulfilled by the Concessioneing Authority. Authority requested to clarify further and provide complete set of the approvals /permits required for the Terminal Asset, Terminal Equipment Phase and Project Facilities and Services indicating the entity responsible for obtaining them (Concessionaire or the Concessioneing Authority)</p> <p>3. Please provide the status of list of list of clearances/permits as</p>	<p>i. Permits/Clearances already obtained shall be shared with Concessionaire</p> <p>ii. IWAI shall assist Concessionaire in obtaining additional permits/clearance</p> <p>iii. All permits/clearances shall be maintained by Concessionaire</p>
----	------	----	----	-----------	-----------------------------------------------------------------------------------------------------------------------------------	---------------------------------------------------------------------------------------------------------------------------------------------------------------------------------------------------------------------------------------------------------------------------------------------------------------------------------------------------------------------------------------------------------------------------------------------------------------------------------------------------------------------------------------------------------------------------------------------------------------------------------------------------------------------------------------------------------------------------------------------------------------------------	--------------------------------------------------------------------------------------------------------------------------------------------------------------------------------------------------------------------------------------------------

					<p>mentioned in Annexure XIII. Please also provide copies of all other clearances and permits that it has already obtained or is in the process of obtaining</p> <p>4. Obtaining of Environment Clearance, CRZ and Forest Clearance for the Project (Terminal's Assets and Terminal Equipment Phase) should be responsibility of the Concessioneing Authority. Authority requested to provide copy of the Environment Clearance, copy of Consent to Establish and Consent to Operate for Terminal's Assets and the Terminal Equipment Phase</p>	
--	--	--	--	--	-------------------------------------------------------------------------------------------------------------------------------------------------------------------------------------------------------------------------------------------------------------------------------------------------------------------------------------------------------------------------------------------------------------------------------------------------------------------------------------------------------------------------------------------------	--

S No	Bidder name	S No as per bidder	Page no	Article no	Text provided in document	Queries with justification (if any)	IWAI response to bidders
28	HIPL	28	26	3	Conditions Precedent	Conditions Precedent should also include a joint site inspection to be carried out by both the Concessionaire and the Concessioneing Authority and observations and results agreed upon by both the parties. Authority requested to include the same in this clause.	Please refer amendment 5
29	HIPL	29	27	3.1.2 (a)	Submission to Concessioneing Authority of its Financing Plan and Financing Documents for the Project and demonstrating Financial Close for verification of the terms and conditions of the Agreement	Please clarify while the Terminal Equipment Phase has to be developed within 4 years from COD the submission of Financing Plan and Documents is required to be complied with within 90 days of Appointed Date. Hence, Authority to exclude this from list of Conditions Precedent of the Concessioneaire.	Please refer Article 3.1.2 for separate timelines set out for Conditions Precedent for Terminals Equipment Phase.

30	HIPL	30	27	3.2.2	Handing over physical possession of the Project Site and Terminal's Assets, free from all encumbrances, after receipt of performance guarantee from the Concessionaire	<p>1. Please provide detailed AUTO CAD version of the Project Site and Terminal's Assets showing all the key components of the Terminal's Assets along with their specifications whose physical possession would be handed over to the Concessionaire.</p> <p>2. Please advise on details of the land area that would be handed over to the Concessionaire without any encumbrance as per Clause 3.2.2 and Article 24 (Annexure II). Such description should include land map, details on area acquired/taken on lease, details of any area pending acquisition details of obstruction, details of any ongoing litigation, neighbouring human habitation and required soil development.</p> <p>3. Please advise on the</p>	<p>1. Please refer Annexure 2 (of this document)</p> <p>2. Please refer Annexure 3 (of this document)</p> <p>3. Permits and Clearances already acquired will be shared with successful bidder. For other details, Articles 2.7 and 2.8 of DCA may be referred.</p>
----	------	----	----	-------	------------------------------------------------------------------------------------------------------------------------------------------------------------------------	----------------------------------------------------------------------------------------------------------------------------------------------------------------------------------------------------------------------------------------------------------------------------------------------------------------------------------------------------------------------------------------------------------------------------------------------------------------------------------------------------------------------------------------------------------------------------------------------------------------------------------------------------------------------------------------------------------------------------	--------------------------------------------------------------------------------------------------------------------------------------------------------------------------------------------------------------------------------------------------------------------

						<p>detailed process for handing over of the physical possession of the Project Site and Terminal's Assets. Authority to provide all certification with regard to compliance to all construction and safety standards for the civil structures and equipment. Authority also requested to provide details of warranties of all civil components and equipment and how these would be applicable to the Concessionaire after the physical handover.</p>	
--	--	--	--	--	--	-------------------------------------------------------------------------------------------------------------------------------------------------------------------------------------------------------------------------------------------------------------------------------------------------------------------------------------------------------------------------------------------------------------------------------------------------------	--

S No	Bidder name	S No as per bidder	Page no	Article no	Text provided in document	Queries with justification (if any)	IWAI response to bidders
31	HIPL	31	30	4	Performance Guarantee	Authority is requested to reduce the Performance Guarantee to 5% of the estimated Project Cost of INR 47.5 cr in line with the Model Concession Agreement for Major Ports.	No change, bid conditions prevail
32	HIPL	32	31	5.4	The Independent Engineer selected pursuant to the aforesaid process shall be appointed within 90 (Ninety) Days of the date of this Agreement	Please advise on the duration of appointment for the Independent Engineer commencing from the appointment date of the Independent Engineer.	Independent Engineer and Independent Surveyor shall be engaged till the termination of concession agreement.
33	HIPL	33	31	5.5	The scope of work of Independent Engineer shall inter-alia include work of certification of Performance Parameters as stipulated in this Concession Agreement	Please provide the definition of Performance Parameters	Performance Parameters shall include conditions of performance such as KPIs as per various provisions of DCA. This is not an exhaustive list.

S No	Bidder name	S No as per bidder	Page no	Article no	Text provided in document	Queries with justification (if any)	IWAI response to bidders
34	HIPL	34	31	5.6 (a)	Concessionaire has taken an informed decision about the size of the vessel and volume of cargo that can pass through the waterway by checking the LAD information updated weekly by the Authority on their website or any other	Authority , requested to note that the Concessionaire is not the entity which decides on the size of the vessel and volume of cargo as these are decision taken by the barge operator basis volume of cargo from clients or shippers and hence the clause may be removed /suitably modified.	No change, bid conditions prevail
35	HIPL	35	33	6.1.1	The Concessionaire shall at its cost, charges and expenses, prepare the detailed technical report (the "DTR") including traffic study and operational design for Development/Equipment Works in conformity with the Scope of Work for the Terminal Equipment Phase.	Please clarify on the timelines of submission of DTR for the Terminal Equipment Phase. Authority , requested to remove traffic study as requirement to be submitted as part of DTR. The DTR should include the design and technical aspects of the Terminal Equipment Phase	No change, bid conditions prevail DTR submission timelines shall be as per Article 3.1.2 of Draft Concession Agreement

S No	Bidder name	S No as per bidder	Page no	Article no	Text provided in document	Queries with justification (if any)	IWAI response to bidders
36	HIPL	36	34	6.3.1	Terminal Equipment Phase: The Concessionaire shall promptly commence and complete the works, including installation of equipment in accordance with the conditions of the Terminal Equipment Phase.....	<p>Please provide the definitions of Terminal Equipment Phase and timeline for commencement of the Terminal Equipment Phase</p> <p>How is this different from the term Development/Equipment Phase</p>	Terminal Equipment Phase shall entail development/construction/equipment works towards the Project as given in Annexure III of Draft Concession Agreement
37	HIPL	37	35	6.4.8	the Concessionaire may, at its cost, interrupt and divert the water or the road traffic or Terminal traffic, adjacent to the Project Site if such interruption and diversion is imperative for efficient progress of Development/Equipment Works and conforms to Good Industry Practice	Please clarify which water body and road does this clause refer to.	Bidders are encouraged to perform their own due diligence

S No	Bidder name	S No as per bidder	Page no	Article no	Text provided in document	Queries with justification (if any)	IWAI response to bidders
38	HIPL	38	35	6.5 & 7.3	Obligations of the Concessioneing Authority	<p>1. The Obligations of the Concessioneing Authority should also include assisting the Concessionaire or Contractor, on a best effort basis, to import into India items of equipment and materials as per requirement for the Expansion Phase of the Project.</p> <p>2. The obligation of the Concessioneing Authority should also include the completion of expansion of approach road to the terminal to 4 lane and the railway linkage to the IWT terminal.</p> <p>3. The Obligation of the Concessioneing Authority , should include dredging and maintenance of LAD at Berthing pocket, turning circle radius, channel and a channel</p>	<p>1. No change, bid conditions prevail</p> <p>2. No change, bid conditions prevail</p> <p>3. Concessioneing Authority shall undertake dredging at berth pocket along with the channel</p>

S No	Bidder name	S No as per bidder	Page no	Article no	Text provided in document	Queries with justification (if any)	IWAI response to bidders
						width sufficient for design vessel size with draft 2.5 m, adequate mooring system, berthing infrastructure including berth fixtures like fenders and navigational aids and facilities complying with best industry practices during the Concession Period. Please confirm.	

S No	Bidder name	S No as per bidder	Page no	Article no	Text provided in document	Queries with justification (if any)	IWAI response to bidders
39	HIPL	39	34	6.3.1	<p>The Concessionaire shall promptly commence and complete the works, including installation of equipment in accordance with the conditions of the Terminal Equipment Phase and shall also obtain from the Independent Engineer a certificate as to completion of development/equipment of Project Facilities and Services in accordance with provisions of this Agreement ("Completion Certificate") not later than 24 months from the date of commencement of the Terminal Equipment Phase.</p>	<p>Please provide the timeline of the commencement date of Terminal Equipment Phase and DTR submission for the same.</p>	<p>DTR to be submitted as per timelines provided in Article 3.1.2 of the Draft Concession Agreement</p>

S No	Bidder name	S No as per bidder	Page no	Article no	Text provided in document	Queries with justification (if any)	IWAI response to bidders
40	HIPL	40	37	6.7.5	Without prejudice to the foregoing, if the Concessionaire fails to complete any Construction Works on account of Force Majeure or for reasons solely attributable to the Concessing Authority, the Concessing Authority may, in its discretion, reduce the scope of Project and require the Concessionaire to pay 80% (eighty percent) of the sum saved due to such reduction of scope	The reduction in the scope of project would definitely have an adverse impact on the project and if a situation as contemplated in this article arises on account of Force Majeure or for reasons solely attributable to the Concessing Authority then such a situation be treated an Event of Default of Concessing Authority. Any reduction of scope leads to reduction in capacity, earnings and therefore any payments to the Concessing Authority does not arise and hence this clause should be deleted	No change, bid conditions prevail

S No	Bidder name	S No as per bidder	Page no	Article no	Text provided in document	Queries with justification (if any)	IWAI response to bidders
41	HIPL	41	37	6.8.1	<p>The Concessing Authority may, notwithstanding anything to the contrary contained in this Agreement, require the provision of additional works and services which are not included in the scope of the Project as contemplated by this Agreement (“Change of Scope”). Provided no such Change of Scope shall be made in the Terminal Equipment Phase if it is in the reasonable judgment of the parties hereto likely to delay the Scheduled Project Completion Date.</p>	<p>A change in scope may potentially result in complications in addition to increasing costs for the Concessionaire in completing the project (Terminal Equipment Phase) within the specified time period. This could lead to unnecessary disputes on where such an implementation results in delay. Hence, this Article should be deleted.</p> <p>Please advise on the definition of Scheduled Project Completion Date</p>	<p>No change, bid conditions prevail.</p> <p>Scheduled Project Completion Date shall imply completion date as indicated by Concessionaire. It shall occur before 4th anniversary of COD.</p>

S No	Bidder name	S No as per bidder	Page no	Article no	Text provided in document	Queries with justification (if any)	IWAI response to bidders
42	HIPL	42	39	6.9	the Concessionaire shall pay to the Concessioneing Authority liquidated damages at the rate of 0.1% (zero point one percent) of the Performance Guarantee for every day of delay in fulfilling specified obligations on or before a Milestone Date....	Please advise on the definition of Milestone Date	Milestone Date may be presented by Concessionaire and approved by Concessioneing Authority before initiating expansion phase
43	HIPL	43	40	7.1	In addition to any of its other obligations under this Agreement, the Concessionaire shall manage, operate, maintain and repair the Project Facilities and Services, entirely at its cost, charges, expenses and risk in accordance with the provisions of this Agreement	Please confirm that the Concessionaire is not expected and required to bear any costs on areas which are not within the Project Site and Terminal's Assets	The Concessionaire shall have to bear expenses as per Scope of Work and obligations as laid out in the DCA.

S No	Bidder name	S No as per bidder	Page no	Article no	Text provided in document	Queries with justification (if any)	IWAI response to bidders
44	HIPL	44	40	7.1.1 (d)	Be free to deploy higher capacity equipment/facilities/ technology, etc. and induct new technology and carry out value engineering for improved productivity and/or improved utilization and/or cost saving of Project assets during the concession period;	While the Concessioiare, in its own interest, would try to maximise operational efficiency , but the same cannot be an obligation and hence Authority requested to delete this clause	No change, bid conditions prevail
45	HIPL	45	40	7.1.1 (f)	Minimize disruption to traffic in the event of accidents or other incidents affecting the safety and use of the Project Facilities and Services ..	The clause may be reworded as " Minimize disruption to traffic in the event of accidents or other incidents affecting the safety within the Project Facilities and Services .."	No change, bid conditions prevail

46	HIPL	46	41	7.1.2	Marine and Terminal Services	<p>1. Under the Model Concession Agreement provision of Marine services as defined under 7.1.2(a) is the obligation of the Concessioneing Authority. Hence , Marine and Terminal Services should be included as the Concessioneing Authority's obligation and responsibility. Further , such services should be provided by the Concessioneing Authority on 24x7 basis.</p> <p>2. If the operator /Concessionaire is expected to carry out Marine Services , the charges towards Pilotage, Towage, Berth Hire , mooring and other berthing ancillary services from the users of the terminal should also be entitlement of the Concessionaire. Authority please confirm.</p> <p>3. Further, Authority to advise on</p> <ul style="list-style-type: none"> - Anticipated largest vessel that will call at the terminal 	<p>1. Pilotage in river channel shall be provided by IWAI as given in Schedule I (Annexure XIV of Concession Agreement)</p> <p>2.. Pilotage for berthing/unberthing for a stretch of 700 m on either side of quay from the central point shall be provided by Concessionaire as per tariff which will be notified as schedule IV on lines of Schedule III (Annexure XIV of Concession Agreement)</p> <p>3. Bidders may perform their own due diligence.</p> <p>4. Pilotage/Towage shall be responsibility of Concessionaire</p> <p>5. The Concessionaire shall have the right of providing priority berthing in view of any volume commitment</p> <p>6. Same as S No. 2 above</p>
----	------	----	----	-------	------------------------------	--------------------------------------------------------------------------------------------------------------------------------------------------------------------------------------------------------------------------------------------------------------------------------------------------------------------------------------------------------------------------------------------------------------------------------------------------------------------------------------------------------------------------------------------------------------------------------------------------------------------------------------------------------------------------------------------------------------------------------------------------------------------------------------------------------------------------------------	-----------------------------------------------------------------------------------------------------------------------------------------------------------------------------------------------------------------------------------------------------------------------------------------------------------------------------------------------------------------------------------------------------------------------------------------------------------------------------------------------------------------------------------------------------------------------------------------------------------------------------------------------------------------------------------

						<ul style="list-style-type: none">- The certification/ training/ experience that a pilot would require- Legislation/ guidelines for vessel pilot exemption- Any suggested type of towage that is required.- Recommendation of Authority for any particular type of craft or Concessionaire can exercise its own discretion <p>4. Authority requested to clarify whether the Concessionaire has to bear additional cost towards arranging of pilotage /towage vessels for providing such services.</p> <p>5. Please elaborate on what is meant by priority berthing norms and the sailing schedule in 7.1.2(a)</p> <p>6. Please provide details on within what distance limit the Concessionaire needs to provide pilotage and towage services at the waterfront on the Project Site. It is expected that IWAI would be</p>	
--	--	--	--	--	--	---------------------------------------------------------------------------------------------------------------------------------------------------------------------------------------------------------------------------------------------------------------------------------------------------------------------------------------------------------------------------------------------------------------------------------------------------------------------------------------------------------------------------------------------------------------------------------------------------------------------------------------------------------------------------------------------------------------------------------------------------------------------------------------------------------------------------------------------------------------------	--

						providing with necessary navigational aids and equipment.	
--	--	--	--	--	--	-----------------------------------------------------------	--

S No	Bidder name	S No as per bidder	Page no	Article no	Text provided in document	Queries with justification (if any)	IWAI response to bidders
47	HIPL	47	41	7.1.2 (c)	Provide for/put in place arrangements for provision of supporting Project Infrastructure other than those covered under the Concession Agreement	Authority to provide clarification on the description of supporting Project Infrastructure	Bidders shall perform their own due diligence to evaluate need of additional supporting infrastructure
48	HIPL	48	41	7.1.2 (d)	Provide office space of 500 sq. ft. for the Concessions Authority within the Terminal Administrative Building	<p>1. Please provide details of total floor space area of the as-built Terminal Administrative Building</p> <p>2. It may be noted that the Administrative Building would be required for purpose of various office use for the Concessionaire and hence Concessions Authority should arrange for an alternate office space for its own use</p>	<p>1. Please refer Annexure 4 (of this document)</p> <p>2. No change, bid conditions prevail</p>

S No	Bidder name	S No as per bidder	Page no	Article no	Text provided in document	Queries with justification (if any)	IWAI response to bidders
49	HIPL	49	42	7.1.5	Removal and/or Replacement of Assets	<p>1. Please confirm that the asset being handed over (Terminal's Assets) has a life of more than 15 years (which is the Concession Period including extension thereof)</p> <p>2. Please provide details of assets which may have to be replaced, considering age and useful life, by the Concessionaire within the Concession Period.</p>	Bidder/Selected Concessionaire may perform own due diligence
50	HIPL	50	43	7.1.10	The Concessionaire may make his own arrangements for security of Project Site and Terminal Assets. The Concessionaire shall abide by the security regulations and procedures prescribed by the Concessions Authority or a competent Government Concessions	Our understanding is that the waterfront security is the responsibility and obligation of the Concessions Authority. Please confirm.	Security in navigation channel shall not be responsibility of Concessionaire

S No	Bidder name	S No as per bidder	Page no	Article no	Text provided in document	Queries with justification (if any)	IWAI response to bidders
					Authority from time to time.		

S No	Bidder name	S No as per bidder	Page no	Article no	Text provided in document	Queries with justification (if any)	IWAI response to bidders
51	HIPL	51	43	7.1.12	The Concessionaire shall endeavor to achieve a minimum annual riverine cargo throughput as per below schedule starting from COD	<p>1. Please clarify on what conversion factors should be used to convert container traffic for computation of traffic handled for the purpose of meeting minimum throughput.</p> <p>2. Authority is requested to remove requirement of Minimum Annual Riverine Cargo from COD to third year operations.</p> <p>3. Authority may note that the Concessionaire has limited control on cargo and hence it cannot guarantee such high minimum throughput during the period of operations. Authority requested to consider reduction of the Minimum Guaranteed Cargo as failure to maintain the same for 3 years triggers an Event of</p>	<p>1. As per Bill of Laden</p> <p>2 and 4. Concessionaire shall endeavour but not be mandated to pay Royalty commensurate with minimum annual riverine cargo as per slabs in Article 7.1.12 (a) upto 10th year of COD</p> <p>3. No change, bid conditions prevail</p>

S No	Bidder name	S No as per bidder	Page no	Article no	Text provided in document	Queries with justification (if any)	IWAI response to bidders
						<p>Default</p> <p>4.Please confirm that Concessionaire is not obliged to pay Royalty commensurate with minimum annual riverine cargo as per slabs in Article 7.1.12 (a) from COD upto 10th year of operations.</p>	

S No	Bidder name	S No as per bidder	Page no	Article no	Text provided in document	Queries with justification (if any)	IWAI response to bidders
52	HIPL	52	45	7.1.16	Cargo Visibility	Please clarify on what does the term end-to-end visibility of cargo implies. Concessionaire can provide visibility of cargo either when it is received at or loaded from the Terminal. Authority requested to modify the clause accordingly.	As IWT entails multimodal transportation, cargo visibility is important from a cargo tracking perspective.
53	HIPL	53	45	7.1.18	Compliance with the Environment Management Plan	The Concessionaire should only be responsible only for compliance with EMP for within the boundary of the Terminal Assets and the project area that is being handed over by the Concessioneing Authority. Authority requested to incorporate the same in the clause accordingly.	Confirmed that EMP compliance shall be maintained for boundary of Project Site and facilities, waterfront and Terminal Assets

S No	Bidder name	S No as per bidder	Page no	Article no	Text provided in document	Queries with justification (if any)	IWAI response to bidders																					
54	HIPL	54	45	7.1.19	The Concessionaire shall take over operation and maintenance of the Waste Reception & Treatment Facility infrastructure at the Terminal from the Concessioneing Authority on COD to provide waste reception services to vessels as per Schedule IV of Ministry of Shipping Notification dated 13 July 2016.	<p>1. Authority requested to provide details of Waste Reception and Treatment Facility infrastructure. The same is not listed in Annexure II (Terminal's Assets) of the Agreement.</p> <p>2. Authority requested to provide copy of Schedule IV of Ministry of Shipping Notification dated 13 July 2016.</p> <p>3. Please confirm that Waste Reception and Treatment Facility infrastructure would be provided by the Concessioneing Authority before handover</p>	<p>1. Details of facilities proposed to be provided are given below:</p> <table border="1"> <thead> <tr> <th>S No</th> <th>Equipment</th> <th>Qty. for MMT Haldia</th> </tr> </thead> <tbody> <tr> <td>1</td> <td>Truck Mounted Sewer Suction Machine of 6000 Lit</td> <td>1</td> </tr> <tr> <td>2</td> <td>Truck Mounted Oil Suction Machine of 2000 Lit</td> <td>1</td> </tr> <tr> <td>3</td> <td>Ride-on type Road Sweeping Machine with Hydraulic Drive Model</td> <td>1</td> </tr> <tr> <td>4</td> <td>Truck Mounted Refuse Compactor 7 m³</td> <td>1</td> </tr> <tr> <td>5</td> <td>Garbage Bins of 1100 Lit suitable for lifting by Garbage Tipper</td> <td>2</td> </tr> <tr> <td>6</td> <td>Garbage Bins of 60 Lit</td> <td>24</td> </tr> </tbody> </table>	S No	Equipment	Qty. for MMT Haldia	1	Truck Mounted Sewer Suction Machine of 6000 Lit	1	2	Truck Mounted Oil Suction Machine of 2000 Lit	1	3	Ride-on type Road Sweeping Machine with Hydraulic Drive Model	1	4	Truck Mounted Refuse Compactor 7 m ³	1	5	Garbage Bins of 1100 Lit suitable for lifting by Garbage Tipper	2	6	Garbage Bins of 60 Lit	24
S No	Equipment	Qty. for MMT Haldia																										
1	Truck Mounted Sewer Suction Machine of 6000 Lit	1																										
2	Truck Mounted Oil Suction Machine of 2000 Lit	1																										
3	Ride-on type Road Sweeping Machine with Hydraulic Drive Model	1																										
4	Truck Mounted Refuse Compactor 7 m ³	1																										
5	Garbage Bins of 1100 Lit suitable for lifting by Garbage Tipper	2																										
6	Garbage Bins of 60 Lit	24																										

S No	Bidder name	S No as per bidder	Page no	Article no	Text provided in document	Queries with justification (if any)	IWAI response to bidders
							<p>2. Please refer Annexure 12</p> <p>3. Waste Reception and Treatment Facility infrastructure would be provided by the Concessioning Authority</p>
55	HIPL	55	45	7.2	Rights of the Concessionaire	Please advise on the provisions related to Unclaimed Cargo	The Concessionaire shall dispose-off unclaimed cargo in accordance with Applicable Law.
56	HIPL	56	46	7.2.1	However, if there is a requirement to offer preferential or priority berthing to any one or more barge operators or vessel owners/operators to optimize the use of Project Facilities and Services, it shall be done based on volume commitments from the Concessionaire's client.	Please note that preferential or priority berthing shall be done on basis of scheduled services being provided to the client and not volume commitment. Authority to accordingly modify this clause.	No change, bid conditions prevail

S No	Bidder name	S No as per bidder	Page no	Article no	Text provided in document	Queries with justification (if any)	IWAI response to bidders
57	HIPL	57	46	7.3.2	If the Authority is not in a position to provide the same, the Concessionaire shall not be entitled to any relaxation on the grounds that its request for additional land, utilities and services was not accepted by the Concessions Authority.	The requirement of additional land, utilities and services is towards the intent of the Concessionaire to maximise the traffic at the terminal and hence if the Authority is not in a position to provide such additional requirements , the Concessionaire should be entitled to relaxation	No change, bid conditions prevail
58	HIPL	58	46	7.3	Obligations of the Concessions Authority	Authority to confirm that maintaining LAD at channel, turning circle and berth pocket , adequate turning circle radius throughout the year for vessels with design draft of 2.5 m should be obligation of the Concessions Authority	Concessions Authority shall endeavour to maintain LAD at channel, berth pockets, adequate turning circle as per Article 7.3.3 of DCA

S No	Bidder name	S No as per bidder	Page no	Article no	Text provided in document	Queries with justification (if any)	IWAI response to bidders
59	HIPL	59	47	7.3.3	The Concessing Authority shall endeavour to provide the Least Available Depth ("LAD") along NW-1 as follows:	As availability of LAD is critical aspect in the waterway operations Authority may consider modifying this clause as The Concessing Authority shall ensure to provide the Least Available Depth ("LAD") along NW-1 as follows:	No change, bid conditions prevail
60	HIPL	60	47	7.3.4	The Terminal Community System would be developed by the Concessing Authority	<p>Please share the description and technical specification for Terminal Community system to be operated/installed by the Concessing Authority. Please confirm if this is a part of the Terminal's Assets.</p> <p>Clause 7.1.9 states that the Concessionaire shall install, operate and maintain such computer system and network (such as Electronic Data Interchange and Terminal Community System). Please clarify as this is in</p>	<p>Terminal shall require computer systems and networks apart from Terminal Community System</p> <p>Concessing Authority shall be responsible for development of Terminal Community System</p>

S No	Bidder name	S No as per bidder	Page no	Article no	Text provided in document	Queries with justification (if any)	IWAI response to bidders
						contradiction with Clause 7.3.4 and confirm that installation , maintenance and operation of Terminal Community System is responsibility of Concessioneing Authority	

61	HIPL	61	47	7.5	<p>Utilities and Services by the Concessionaire</p> <p>The Concessions Authority shall, during the Concession Period, provide access to the Concessionaire for all infrastructure facilities and utilities including water, electricity and telecommunication facilities necessary for the implementation, operations and management of the Project Facilities and Services in accordance with this Agreement, at rates and on terms no less favourable to the Concessionaire than those generally available to commercial customers availing substantially equivalent facilities and utilities.</p>	<p>1. Please clarify what would be the access/take off point for water and telecommunication facilities. If there is any requirement for construction of transmission/pipeline to draw such facilities from the access point to the site the Authority should consider this as an obligation of the Concessions Authority.</p> <p>2. Please indicate the rated capacities of the utilities and services that would be made available and whether these are sufficient to meet the capacity of 3.08 mmtpa.</p> <p>3. As an obligation of Concessions Authority under the Agreement, Authority to also ensure the adequacy of the utilities and services provided by it to the Concessionaire in order to enable the Concessionaire to perform its obligation</p>	<p>1. Please refer Article 7.5 of Draft Concession Agreement</p> <p>2. Please refer as-built layout provided in Annexure 2</p> <p>3. Please refer Article 7.5 of Draft Concession Agreement</p> <p>4 & 5. Standard tariff rates of respective utility provider shall be applicable</p>
----	------	----	----	-----	------------------------------------------------------------------------------------------------------------------------------------------------------------------------------------------------------------------------------------------------------------------------------------------------------------------------------------------------------------------------------------------------------------------------------------------------------------------------------------------------------------------------------------------------------------------------------------------------------	-----------------------------------------------------------------------------------------------------------------------------------------------------------------------------------------------------------------------------------------------------------------------------------------------------------------------------------------------------------------------------------------------------------------------------------------------------------------------------------------------------------------------------------------------------------------------------------------------------------------------------------------------------------------------------------------------------------------------------------------------------------------	--------------------------------------------------------------------------------------------------------------------------------------------------------------------------------------------------------------------------------------------------------------------------------------------

					<p>under the Concession Agreement.</p> <p>4. Please provide the present applicable rates for providing utilities and services i.e. water, electricity and telecommunication facilities.</p> <p>5. Authority to confirm the rates and terms should be no less favourable to the Concessionaire than those generally available to commercial customers availing substantially equivalent facilities and utilities and from the same service providers.</p>	
--	--	--	--	--	----------------------------------------------------------------------------------------------------------------------------------------------------------------------------------------------------------------------------------------------------------------------------------------------------------------------------------------------------------------------------------------------------------------------------------------------------------	--

S No	Bidder name	S No as per bidder	Page no	Article no	Text provided in document	Queries with justification (if any)	IWAI response to bidders
62	HIPL	62	48	7.5 (c)	The Concessionaire may, at its cost, make alternate arrangements for power including but not limited to installation of generators, subject to obtaining Applicable Permits, if any.	Please consider the following modification The Concessionaire may, at its cost and option, make alternate arrangements for power including but not limited to installation of generators, subject to obtaining Applicable Permits, if any.	No change, bid conditions prevail
63	HIPL	63	49	8.1.1	Levy and Recovery of Tariff: The Concessionaire shall levy and recover Tariff from the users of the Project Facilities and Services as per Annexure XIV. The tariff document as per Annexure XIV prescribes the maximum tariff that can be levied by the Concessionaire ("Ceiling Tariff").	Please confirm that the tariff applicable to non-riverine cargo are not regulated and Concessionaire can independently decide on tariff charges for the above category of traffic	Ceiling Tariffs (and mechanism for revision) as given in Proposed Schedule IV (Annexure XIV of DCA) shall be mutually agreed between Concessionaire and Concessions Authority. Concessions Authority shall get the same notified.

S No	Bidder name	S No as per bidder	Page no	Article no	Text provided in document	Queries with justification (if any)	IWAI response to bidders
64	HIPL	64	49	8.1.2	The Ceiling Tariff shall be revised every year based on a variation in the Wholesale Price Index ("WPI"). Such revision shall be based on indexation against 60% (sixty percent) of the variation in the WPI for a relevant year beginning 1st January and ending 31st December.	<p>1. Please advise, in case the Concessionaire desires to increase the Tariff by more than 60% of variation in WPI , what should be the guiding provision. The escalation of Ceiling Tariff should be left open to the Concessionaire to decide basis its own assessment of the competitive scenario.</p> <p>2. While 8.1.2 defines the applicable escalation of Royalty based on predetermined rate of 60% of the variation of WPI, 8.1.3 brings the revised Ceiling Tariff under purview of regulations as per Section 17 of the Inland Waterways Authority Act, 1985. Please clarify which of 8.1.2 and 8.1.3 would be the final guiding principle for determining</p>	<p>1. No change, bid conditions prevail.</p> <p>2. Under powers vested in IWAI as per Section 17 of the Inland Waterways Authority Act, 1985, Concessioning Authority determines (and notify) escalation mechanism for Ceiling Tariffs for this Concession Agreement. Concessioning Authority has adopted escalation mechanism recommended by Model Concession Agreement for Major Ports (January 2018) for tariff. Therefore, tariff escalation shall be based on indexation against 60% (sixty percent) of the variation in the WPI for a relevant year beginning 1st January and ending 31st December.</p>

S No	Bidder name	S No as per bidder	Page no	Article no	Text provided in document	Queries with justification (if any)	IWAI response to bidders
						escalation as Section 17 of the Inland Waterways Authority Act, 1985 states the requirement of approvals from Central Government for tariff fee and charges.	

S No	Bidder name	S No as per bidder	Page no	Article no	Text provided in document	Queries with justification (if any)	IWAI response to bidders
65	HIPL	65	49	8.1.3	The revised Ceiling Tariff shall be regulated as per Section 17 of the Inland Waterways Authority Act, 1985. Such revised Ceiling tariff will become applicable after the same has been notified by the Concessioneing Authority.	Please provide copy of the regulations referred to here	Please refer Annexure 5 (of this document)
66	HIPL	66	50	9.1.1	The Concessionaire shall, as consideration for the use, in its capacity as a bare licensee of the Project Site and the equipment comprised in the Terminal's Assets, made available in accordance with Article 2.4, pay to the Concessioneing Authority the sum of Re 1	Please clarify the provision for escalation of License Fee	As per bid provisions, there shall be no escalation on License Fee

S No	Bidder name	S No as per bidder	Page no	Article no	Text provided in document	Queries with justification (if any)	IWAI response to bidders
67	HIPL	67	50	9.1.2	Any delay in payment of the amount in the preceding Article 9.1.1 shall entail payment of interest @ 10 Year GSec plus 6% (Six percent) per annum on the amount outstanding.	The interest rate of 10 Year Gsec plus 6% per annum is substantially high. Accordingly, Authority requested to reconsider and reduce the rate to 10 Year Gsec plus 2% per annum	No change, bid conditions prevail
68	HIPL	68	50	9.2.1	The Concessionaire shall make payments to the Concessioneing Authority an amount equivalent to the quoted Royalty plus a premium of 20% (twenty percent) on quoted Royalty for Non-Riverine cargo handled during the previous month. Such payments shall commence from 2nd (second) month (pertaining to previous month) after COD until Termination.	Authority requested to keep the Royalty amount for non-riverine cargo similar to riverine cargo	No change, bid conditions prevail

S No	Bidder name	S No as per bidder	Page no	Article no	Text provided in document	Queries with justification (if any)	IWAI response to bidders
69	HIPL	69	50	9.2.3	Royalty for each month shall be paid on or before the 7th (seventh) day of the following month.	The Royalty would be paid on or before the 7th (seventh) day of the following month subject to receiving of invoice from Authority. Please confirm.	No change, bid conditions prevail
70	HIPL	70	50	9.2.4	Royalty amounts remaining unpaid on respective due dates would carry interest @ 10 year GSec plus 6% (Six percent) per annum from the due date till the date of payment.	The interest rate of 10 Year Gsec plus 6% per annum is substantially high. Accordingly, Authority requested to reconsider and reduce the rate to 10 Year Gsec plus 2% per annum	No change, bid conditions prevail
71	HIPL	71	51	9.3.2	The Concessing Authority may, at its own cost, appoint a firm of chartered accountants duly licensed to practice in India and empaneled by CAG ("Additional Auditor") to conduct a special audit of the cargo throughput and the financial statements,	Authority to clarify on the scope of special audit with respect to the financial statements, document and other supporting evidence.	Scope of special audit regarding cargo throughput and financial statements shall depend on Performance of Concessionaire No change, bid conditions prevail

S No	Bidder name	S No as per bidder	Page no	Article no	Text provided in document	Queries with justification (if any)	IWAI response to bidders
					documents and supporting evidences thereto as may be mandated by the Concessioneing Authority		
72	HIPL	72	51	9.3.3	Further, the Concessionaire shall reimburse all costs, charges and expenses related to Special Audit	The costs, charges and expenses of the Special Audit should be borne by the Concessioneing Authority. Authority requested to suitably modify the clause	No change, bid conditions prevail
73	HIPL	73	51	9.4	Withdrawals and appropriations during the Concession Period, at any relevant time, from the Escrow Account shall be in the following order of priority:	Authority requested to relax the requirement of an Escrow Ac as the Concessionaire is required to submit a Performance Guarantee towards its obligations and performance under the Concession Agreement.	No change, bid conditions prevail

S No	Bidder name	S No as per bidder	Page no	Article no	Text provided in document	Queries with justification (if any)	IWAI response to bidders
74	HIPL	74	51	9.4.1	Withdrawals and appropriations during the Concession Period, at any relevant time, from the Escrow Account shall be in the following order of priority:	Payment towards Concessionaire's debt service obligations under Financing documents should have precedence in order of priority to payment of Royalty and other sums payable to the Concessing Authority and liquidated damages, if any; Authority may note that the same is according to the provisions of the Model Concession Agreement of Ports	Please refer Amendment no. 10 and Amendment no. 15

S No	Bidder name	S No as per bidder	Page no	Article no	Text provided in document	Queries with justification (if any)	IWAI response to bidders
75	HIPL	75	58	12.1.3 (ii)	<p>Insurance Cover & Insurance Companies: The Concessionaire shall insure all insurable Terminal's Assets and Project Facilities and Services and all insurable risks associated with Project to the extent advisable in accordance with Good Industry Practice ("Insurance Cover"). Insurance of IWAI assets to be taken with zero deductible franchise to ensure maximum proceeds.</p>	<p>1. Please note that as per standard industry practice zero deductible policy is not required for Insurance Cover. More so the premium of zero deductible cover would be disproportionately high and hence difficult to bear for the Concessionaire. Authority requested to consider relaxing the requirement of zero deductible policy.</p> <p>2. Authority to further confirm, that insurance of all Terminal's Assets and Project Facilities and Services associated with Project would be done at replacement cost of such assets.</p>	No change, bid conditions prevail

S No	Bidder name	S No as per bidder	Page no	Article no	Text provided in document	Queries with justification (if any)	IWAI response to bidders
76	HIPL	76	59	12.1.4	Indemnification	The Concession Agreement should also include indemnification to be provided by the Concessioneing Authority to keep indemnified and otherwise save harmless, the Concessionaire, its agents and employees. Accordingly please incorporate the necessary clause.	No change, bid conditions prevail
77	HIPL	77	60	12.1.6	The Concessionaire shall engage the Management Contractor and execute the Management Contract, thereby entrusting the Management Contractor with the responsibilities of operating and managing the Project Facilities and Services in the manner envisaged under the Request for Proposal	Authority requested to delete this clause as the requirement of Management Contractor is not necessary.	No change, bid conditions prevail

S No	Bidder name	S No as per bidder	Page no	Article no	Text provided in document	Queries with justification (if any)	IWAI response to bidders
78	HIPL	78	61	12.2	General Rights, Duties and Obligations of the Concessioneing Authority	Authority requested to grant exclusivity and not operationalize any additional terminal to handle riverine cargo for both captive and commercial purpose within a radial distance of 100 km from the Project Site during the period of Concession	No change, bid conditions prevail

S No	Bidder name	S No as per bidder	Page no	Article no	Text provided in document	Queries with justification (if any)	IWAI response to bidders
79	HIPL	79	64	13	<p>In the alternative to the aforesaid, subject to the Concessionaire taking necessary measures to mitigate the impact or the likely impact of Change in Law on the Project, if as a direct consequence of a Change in Law, the Concessionaire is obliged to incur Additional Cost in any accounting year, any such Additional Cost above a sum of INR 2.4 crore (INR Two crore and forty lakh only) may at the option of the Concessioneing Authority be borne by the Concessioneing Authority. It is clarified that Additional Cost upto INR 2.4 crore (INR Two crore and forty lakh only) in any accounting year shall</p>	<p>It may be noted that additional cost of INR 2.4 cr is likely to be comparable to or more than revenue in initial few years. Thus, an onus on the Concessionaire to bear such amount additional cost would have negative impact on the viability of the Project. Hence , Authority is requested to reduce the threshold of the Additional cost to INR 0.6 cr.</p>	<p>No change, bid conditions prevail</p>

S No	Bidder name	S No as per bidder	Page no	Article no	Text provided in document	Queries with justification (if any)	IWA response to bidders
					be borne by the Concessionaire;		
80	HIPL	80	69	14.4.1 (f)	Insufficient LAD on NW-1 for a period of 7 (seven) Days or more as communicated by the Authority through a public notification.	Authority to note that Insufficiency of LAD for period of 7 days on more than one occasion would potentially impact the project viability and hence such an event should be treated as Event of Default of the Concessioneing Authority	No change, bid conditions prevail

S No	Bidder name	S No as per bidder	Page no	Article no	Text provided in document	Queries with justification (if any)	IWAI response to bidders
						and not a Force Majeure as indicated in this Clause	
81	HIPL	81	72	15.1.1 (iii)	Delay of more than 180 (one hundred and eighty) Days from any Milestone Date in achieving any of the performance obligations set forth for the relevant Milestone Date or the Date of Commercial Operations is delayed for more than 180 (one hundred and eighty) Days from the Scheduled Project Completion Date;	<p>1. Please advise on the definition of Milestone Date ,Date of Commercial Operations and Scheduled Completion Date</p> <p>2. Authority is requested to consider Concessionaire Event of Default only in case of delay in Date of Commercial Operations and not on all Milestone Dates as stated here.</p>	<p>1. Milestone Date may be presented by Concessionaire and approved by Concessioneing Authority before initiating expansion phase</p> <p>Date of Commercial Operations shall imply the date of commencement of operations after fulfilment or waiver of Conditions Precedent</p> <p>Scheduled Project Completion Date shall imply completion date as indicated by Concessioniare. It shall occur before 4th anniversary of COD.</p> <p>2. No change, bid conditions shall prevail</p>

S No	Bidder name	S No as per bidder	Page no	Article no	Text provided in document	Queries with justification (if any)	IWAI response to bidders
82	HIPL	82	72	15.1.1(vii)	Minimum annual riverine cargo throughput as per Article 7.1.12 is not met in at least 3 (three) years between the 4th (fourth) year and 8th (eighth) year of Concession Period	The proviso in Clause 15.1.1 (vi) should also be applicable to 15.1.1 (vii) i.e. "Provided, the Concessionaire shall not be deemed to be in default if such non achievement is due to a substantial change in economic policies including the policy regarding import/export of a particular commodity as a result of which the throughput could not be achieved;". Authority requested to modify this clause accordingly.	No change, bid conditions prevail
83	HIPL	83	81	17.1.2	Provided, no compensation shall be payable to the Concessionaire if the Concessionaire fails to maintain Insurance Cover as contemplated under Article 12 of this Concession Agreement.	It is not understood how is maintaining insurance cover relevant to compensation for Termination due to Concessionaire Event of Default. Authority requested to clarify and consider suitably modifying the clause.	No change, bid conditions prevail

S No	Bidder name	S No as per bidder	Page no	Article no	Text provided in document	Queries with justification (if any)	IWAI response to bidders
84	HIPL	84	80	17.1.2	<p>Termination due to Concessionaire Event of Default If the termination is after the Date of Commercial Operation, due to a Concessionaire Event of Default, the compensation payable by the Concessioneing Authority to the Concessionaire shall be the lowest of:</p> <p>(a) the Book Value; (b) 90% (ninety percent) of Debt Due; (c) the Total Project Cost;</p>	<p>1. One would find that there would be steady reduction in the amount of debt due over a period of time. Therefore in such cases the use of debt due may not be an appropriate compensation especially if it is meant to be "lowest of". It may be further noted that if the actual capital cost of the Project is materially higher than INR 47.5 Cr than the Total Project Cost shall not be an appropriate compensation. Therefore Authority is suggested to consider highest of the book value , debt due, Total Project Cost as the compensation payable to the Concessionaire</p> <p>2. Please advise on the compensation payable to the Concessionaire in</p>	No change, bid conditions prevail

S No	Bidder name	S No as per bidder	Page no	Article no	Text provided in document	Queries with justification (if any)	IWAI response to bidders
						case of termination before the Date of Commercial Operation	

S No	Bidder name	S No as per bidder	Page no	Article no	Text provided in document	Queries with justification (if any)	IWAI response to bidders
85	HIPL	85	81	17.2	In the event of expiry of Concession Agreement by efflux of time (the Concession Agreement having run its full course), the Concessionaire shall hand over/ transfer peaceful possession of the Project Site including land, Terminal's Assets and the Project Facilities and Services free of cost and Encumbrance.	The Concessionaire shall hand over/ transfer peaceful possession of the Project Site including land, Terminal's Assets and the Project Facilities and Services free of cost except for all moveable assets that were procured by the Concessionaire which the Concessionaire shall be entitled to remove from site free of any costs. Please confirm	No change, bid conditions prevail
86	HIPL	86	84	18.2.4	transfer technology and up-to-date know-how relating to operation and maintenance of the Terminal's Assets and/or the Project Facilities and Services	Please specify what is implied by transfer of technology and up to date know-how.	At the end of concession period, Concessionaire shall be obliged to update/train Concessioning Authority personnel in the use of any technology implemented (hardware and software) for smooth transfer of operations.
87	HIPL	87	97	23, Annexure I	Please refer to the attached CAD drawing for Project site's details including Terminal and Passenger pontoon jetty.	Please share Auto CAD drawing version of Project site which shall also show details of, layout plan, boundary of the site , various	Please refer Annexure 2 (of this document)

S No	Bidder name	S No as per bidder	Page no	Article no	Text provided in document	Queries with justification (if any)	IWAI response to bidders
						components listed in Terminal's Assets and the road/rail connectivity.	

88	HIPL	88	98	Annexure II	<p>The following is the list of Terminal's assets to be handed over to the Concessionaire.</p>	<p>Authority requested to provide clarification on the following</p> <ol style="list-style-type: none"> 1. Please provide all as-built drawings along with details of specifications/standards and quantity/dimensions of all the Immoveable and moveable assets as included in Annexure II including the spec and number of forklifts, barge loaders, weighbridge, front end loader and the conveyor silo system. 2. Please advise on the status of construction and installation of the various moveable/immoveable assets as listed in Annexure II 4. Please advise on the completed back up area including warehousing, sheds, storage yards, internal roads which would be part of the Terminal's Assets to be handed over to the Concessionaire. Further, please confirm that the developed back up area is 	<p>1 & 4 & 10) Please refer Annexure 2 (of this document)</p> <p>2) Physical progress is 89%</p> <p>5) Please refer Annexure 3 (of this document)</p> <p>6) Please refer Annexure 4 (of this document)</p> <p>7 &8) Please refer DPR</p> <p>9) Please refer IWAI website</p>
----	------	----	----	-------------	------------------------------------------------------------------------------------------------	----------------------------------------------------------------------------------------------------------------------------------------------------------------------------------------------------------------------------------------------------------------------------------------------------------------------------------------------------------------------------------------------------------------------------------------------------------------------------------------------------------------------------------------------------------------------------------------------------------------------------------------------------------------------------------------------------------------------------------------------------------------------------------------------------------------------------------------------------	------------------------------------------------------------------------------------------------------------------------------------------------------------------------------------------------------------------------------------------------------------------------------------------

						<p>sufficient for capacity of 3.07 mmtpa.</p> <p>5. Details of any obstruction/encroachments on the land area to be handed over by Authority</p> <p>6. Please provide details of Buildings in the Terminal's Assets. The Concessionaire should be provided with Administrative building, security office, power substation, weigh bridge cabin, water pump station, control room with systems. etc</p> <p>7. Please provide the current capacity at the 4 berths and back up yard with the Equipments as provided by the Concessioning Authority under Terminal's Assets</p> <p>8. Please provide details of S No 6 ; Water System</p> <p>9. Please provide the location of the minor bridges.</p> <p>10. Please provide layout of internal roads as would be provided to Concessionaire</p>	
--	--	--	--	--	--	----------------------------------------------------------------------------------------------------------------------------------------------------------------------------------------------------------------------------------------------------------------------------------------------------------------------------------------------------------------------------------------------------------------------------------------------------------------------------------------------------------------------------------------------------------------------------------------------------------------------------------------------------------------------------------------------------------------------------------------------------------------------------------------------	--

S No	Bidder name	S No as per bidder	Page no	Article no	Text provided in document	Queries with justification (if any)	IWAI response to bidders
89	HIPL	89	98	Annexure II , Terminal's Assets	Roads	<p>1. Please provide the current width and estimated timeline when the approach road to the site would be expanded to 4 lane.</p> <p>2. Also please confirm that expansion of the approach road would be obligation of the Concessioneing Authority.</p> <p>3. Please provide the final layout of all internal roads that would be completed by Authority and handed over to Concessionaire</p>	<p>Two-lane road has been constructed by IWAI</p> <p>Please refer Annexure 2 (of this document)</p>

S No	Bidder name	S No as per bidder	Page no	Article no	Text provided in document	Queries with justification (if any)	IWAI response to bidders
90	HIPL	90	100	Annexure III, Point 2	the design, planning, procurement and installation of equipment at Terminal to increase design capacity of Terminal to at least 3.07 mmtpa;	<p>1. Authority confirm that the only equipment to be procured/installed by Concessionaire are MHC - 1 nos. and Dumper Trucks - 10 nos.</p> <p>2. Please confirm that the Terminal Assets along with equipment to be provided by Concessionaire as per Annexure II, Point 4 is sufficient to guarantee capacity of 3.07 mmtpa in all respect both on the berth side and back up area.</p> <p>3. Authority requested to provide details of capacity of Terminal on an as is basis currently.</p>	<p>1. Details of equipment to be provided by Concessionaire may be found in DPR (which is provided as Annexure XVI of DCA). The Concessionaire may opt for alternate equipment and such provisions are given in Annexure III of DCA on Scope of Work</p> <p>2. Berthside capacity of Terminal is 3.07 mmtpa</p> <p>3. Haldia MMT development is at advanced stages of completion. The terminal is not operational.</p>

S No	Bidder name	S No as per bidder	Page no	Article no	Text provided in document	Queries with justification (if any)	IWAI response to bidders
91	HIPL	91	100	Annexure III	Scope of Work : Terminal Equipment Phase	<p>1. Please provide break up of the estimated project cost of INR 47.5 cr as per the items to be constructed/development to be carried out during the Terminal Equipment Phase by the Concessionaire</p> <p>2. Please confirm that the only immovable assets/movable assets/equipment to be provided by the Concessionaire at the Project Site is one Mobile Harbour Crane and 10 dumper trucks and that these together with the Terminal's Assets provided by the Concessioneing Authority is sufficient to meet overall capacity of 3.07 mmtpa</p>	<p>1. Please refer Annexure 1 to this document</p> <p>2. Please refer Annexure III and Annexure XVI of Draft Concession Agreement</p>

S No	Bidder name	S No as per bidder	Page no	Article no	Text provided in document	Queries with justification (if any)	IWAI response to bidders
92	HIPL	92	101	26, Annexure IV	Performance Standards and Damages	It is important that just as the Concession Agreement specifies the performance standards and liquidated damages and penalties for the Concessionaire the same principle should be adopted and applied for the Concessions Authority in case it fails to meet its performance and the Concessionaire be suitably compensated on account of such failure. Such Performance Standards requirement of the Concessions Authority should not be limited only to LAD maintenance but should also include stipulations in providing of utilities and supporting infrastructure, navigational aid and any other facilities (not under the scope of the Concessionaire) whose	No change, bid conditions prevail

S No	Bidder name	S No as per bidder	Page no	Article no	Text provided in document	Queries with justification (if any)	IWAI response to bidders
						failure can impact the performance of the Concessionaire.	
93	HIPL	93	103	26, Annexure IV	Average turnaround time of trucks (operational)	It may be noted that 120 mins would be applicable only to handling of containers. Trucks with bagged/break bulk cargo that has to be destuffed in smaller units would take much longer time to turnaround. Authority	Please refer amendment 11

S No	Bidder name	S No as per bidder	Page no	Article no	Text provided in document	Queries with justification (if any)	IWAI response to bidders
						requested to modify the requirement accordingly.	
94	HIPL	94	106	26, Annexure IV	The induced performance shortfall for the Concessionaire will be used to calculate a notional penalty per day which would have been paid by the Concessionaire if there was equal operational performance shortfall only for the duration when LAD was not available beyond 48 hours.	IWAI to be paid penalty in cases of disruptions of more than 48-hour period on failure to meet LAD commitment. However, no such allowance is given to Concessionaire on LD calculations for not meeting performance standards during the said 48-hour period. The threshold duration of shortfall for calculation of penalty should be same for Concessioneing Authority and Concessionaire.	No change, bid conditions prevail

S No	Bidder name	S No as per bidder	Page no	Article no	Text provided in document	Queries with justification (if any)	IWAI response to bidders
95	HIPL	95	107	26, Annexure IV	Before 2nd anniversary of the COD, the Concessing Authority shall not be liable to pay any penalty for shortfall in LAD	Authority to revise Clause 26 to exempt the Concessionaire from paying penalty due to performance shortfall for the first two years from COD to keep the terms for the Concessionaire and Concessing Authority symmetrical.	No change, bid conditions prevail
96	HIPL	96	105	Annexure IV	Calculation of penalty in case of shortfall in LAD maintenance: The Concessing Authority shall be liable for such penalty only in stretches upstream of Tribeni which is located at a chainage distance of 193 km on National Waterway-1.	<p>1. Please advise what is meant by the 'stretches upstream of Tribeni' with details of the end points of this chainage on NW 1</p> <p>2. As there could be traffic from stretch south of Tribeni. I.e. Between Tribeni and Haldia, Authority should be liable for penalty for failure of maintenance of LAD (as per 7.3.3.)for the entire waterway stretch between Varanasi and Haldia in order to ensure maximum traffic</p>	<p>1. Stretches from Varanasi to Tribeni. For chainage data, refer to river notices on IWAI website</p> <p>2. Authority will assist the Concessionaire on best effort basis to assure LAD downstream of Tribeni'</p>

S No	Bidder name	S No as per bidder	Page no	Article no	Text provided in document	Queries with justification (if any)	IWAI response to bidders
						movement over the waterway.	

S No	Bidder name	S No as per bidder	Page no	Article no	Text provided in document	Queries with justification (if any)	IWAI response to bidders
97	HIPL	97	105	Annexure IV	<p>Independent Surveyor shall validate/ certify that unsuccessful passage is not due to Concessionaire default subject to the following conditions:</p> <p>i. Concessionaire has taken an informed decision about the size and draft of the vessel and volume of cargo that can pass through National Waterway-1 by duly checking the LAD information updated periodically by the Authority on their website or any other source of information used in the future.</p> <p>ii. Concessionaire has adhered to the National Waterway-1 channel as declared by the Authority in their navigational charts updated periodically.</p>	<p>1. Please note that the Concessionaire is not the entity that decides the size and draft of vessels as it does not have any control on barge operations.</p> <p>2. Similarly , as Concessionaire is not in control of barge movement in NW-1 channel and hence there is no question of it adhering to navigational charts as provided by IWAI.</p> <p>Authority, accordingly requested to delete this clause.</p>	No change, bid conditions prevail

S No	Bidder name	S No as per bidder	Page no	Article no	Text provided in document	Queries with justification (if any)	IWAI response to bidders
98	HIPL	98	105	Annexure IV	<p>Concessionaire will immediately communicate such instance to the Concessions Authority. The Concessions Authority will then have 48 (forty eight) hours to rectify the shortfall in LAD to ensure passage of vessel.</p>	<p>Complains about such instances of unsuccessful passage should not be left alone to the Concessionaire , rather any transporter , barge operator or cargo owner using NW 1 channel should be entitled to bring such instances to the notice of IWAI. This would be required so that stakeholders using the waterway are not hesitant to use larger vessels thus impacting the drive for traffic maximisation.</p>	<p>No change, bid conditions prevail</p>

S No	Bidder name	S No as per bidder	Page no	Article no	Text provided in document	Queries with justification (if any)	IWAI response to bidders
99	HIPL	99	106	Annexure IV	<p>Calculation of penalty in case of shortfall in LAD maintenance</p> <p>As also given above regarding Performance Standards for Concessionaire, liability for penalty shall be capped at 50% of Royalty payable by Concessionaire for cargo carried by vessel which was unable to pass due to LAD shortfall.</p> <p>For avoidance of doubt, it may be stated that the maximum liability for penalty as calculated above shall be the upper cap of Royalty that the Concessioning Authority shall forgo.</p>	<p>Please clarify as the two paragraphs does not seem to be consistent. While as per the first paragraph the liability for penalty shall be capped at 50% of Royalty payable by Concessionaire , as per the second paragraph it is the upper cap of Royalty the Concessioning Authority shall forgo. Request elaborate with an example.</p>	<p>Penalty for Concessioning Authority is capped at 50% of Royalty payable for cargo carried by vessel which was unable to pass due to LAD shortfall.</p> <p>Concessioning Authority shall be liable for penalty in the form of forgoing royalty amount as stated above.</p>

S No	Bidder name	S No as per bidder	Page no	Article no	Text provided in document	Queries with justification (if any)	IWAI response to bidders
100	HIPL	100	105	Annexure IV	<p>Calculation of penalty in case of shortfall in LAD maintenance: Penalty component shall be capped at 50% of Royalty for the vessel unable to pass due to shortfall in LAD which shall be calculated on the basis of Royalty per MT to be paid by Concessionaire and volume of cargo carried by the vessel which was delayed due to LAD shortfall.</p>	<p>While in case of LAD shortfall , the Concessioning Authority is liable to pay penalty basis the Royalty payable on the volume of cargo carried by the affected vessel, in case of performance KPI shortfall by Concessionaire the penalty is calculated based on Royalty of the respective quarter. We believe that the calculation of penalty for both parties should be consistent w.r.t time interval considered for computation</p>	<p>No change, bid conditions prevail</p>

S No	Bidder name	S No as per bidder	Page no	Article no	Text provided in document	Queries with justification (if any)	IWAI response to bidders
101	HIPL	101	110	27. Annexure V, 3.1	<p>i. Concessionaire has taken an informed decision about the size of the vessel and volume of cargo that can pass through the waterway by checking the LAD information updated weekly by the Authority on their website or any other source of information used in the future.</p> <p>ii. Concessionaire has adhered to the waterway channel as declared by the Authority in their navigational charts updated periodically.</p>	<p>1. Please note that the Concessionaire is not the entity that decides the size and draft of vessels as it does not have any control on barge operations.</p> <p>2. Similarly , as Concessionaire is not in control of barge movement in NW-1 channel and hence there is no question of it adhering to navigational charts as provided by IWAI.</p> <p>Authority, accordingly requested to delete this clause.</p>	No change, bid conditions prevail
102	HIPL	102	110	Annexure VI	Escrow Agreement	The Escrow Agreement shall be subject to the Escrow Bank agreeing to all terms of the Escrow Agreement .	Please refer Amendment no 10 and Amendment no 15

S No	Bidder name	S No as per bidder	Page no	Article no	Text provided in document	Queries with justification (if any)	IWAI response to bidders
103	HIPL	103	115	Annexure VI, 4.1	Withdrawals during Concession Period	<p>As per the Model Concession Agreement and also as per Clause 9.4 the following two payments should precede payments to Concessioneing Authority and towards its debt service obligations under the Financing Documents</p> <p>(e) all development/implement ation expenses relating to the Project/Project Facilities and Services, in accordance with the Budget and subject to limits if any set out under the Financing Documents;</p> <p>(f) all expenses relating to operations and management of the Project/Project Facilities and Services, in accordance with the Budget and subject to limits if</p>	Please refer amendment 10

S No	Bidder name	S No as per bidder	Page no	Article no	Text provided in document	Queries with justification (if any)	IWAI response to bidders
						any set out under the Financing Documents; Authority requested to modify the Clause accordingly.	

S No	Bidder name	S No as per bidder	Page no	Article no	Text provided in document	Queries with justification (if any)	IWAI response to bidders
104	HIPL	104	118	Annexure VI, 6.1.2	Upon occurrence of an Escrow Default, the consequences thereof shall be dealt with under and in accordance with the provisions of the Concession Agreement.	Please clarify the clause in the Concession Agreement which provides such provisions applicable during occurrence of an Escrow Default.	Please refer Article 15.1.1
105	HIPL	105	127	30, Annexure VIII, 2.1	The Concessionaire shall, at all times during the Concession Period, at its own risk, cost, charges and expenses, performance and pay for maintenance repairs, and renewals of various type of assets and equipment in the Concessionaire premises and /or the project or any parts thereof, whether due to use and operations or due to deterioration of materials and /or parts, so that on the expiry or	Please note that if any deterioration occur to the structure of any asset which was part of the Terminal's Assets handed over to Concessionaire before COD, either owing to inferior designs or bad workmanship , the Concessionaire will not be responsible for the handing over of the structure in its original condition(other than normal wear and tear) , at the expiry of the Concession period.	No change, bid conditions prevail

S No	Bidder name	S No as per bidder	Page no	Article no	Text provided in document	Queries with justification (if any)	IWA response to bidders
					<p>termination of Concession Period, the same shall except normal wear and tear be in good working condition as it were at the time of commencement of the Concession Period.</p>		
106	HIPL	106	129	30, Annexure VIII, 4.3	<p>The facility shall be designed such that in the event a fault occurs, a limited service can be provided within a few minutes by isolation of the affected area or equipment, to the extent possible.</p>	<p>Please provide drawings/ plans for Restoration of services</p>	<p>Concessionaire may prepare its own plan suitably</p> <p>Please refer Annexure 13 and Annexure 14</p>

S No	Bidder name	S No as per bidder	Page no	Article no	Text provided in document	Queries with justification (if any)	IWAI response to bidders
107	HIPL	107	129	30, Annexure VIII, 4.4.1 (h)	The Concessionaire shall procure and ensure that appropriate contingency arrangements are in place at the Terminal to deal with the following events in accordance with applicable guidelines of IWAI:	Please note that the Concessionaire shall ensure appropriate contingency arrangements only in situations and cases where the listed events have occurred inside the area handed over to the Concessionaire (Project Site and Terminal's Assets). The Concessionaire cannot be held responsible for events occurring outside the above mentioned area.	No change, bid conditions prevail
108	HIPL	108	129	30, Annexure VIII, 4.4.2	The Concessionaire shall procure and ensure that the emergency alarm bells are installed and operated to link the terminal control Facility to the Terminal in charge	Please clarify the term "terminal control Facility". Does the existing Terminal's Assets consist of alarm bells ?	Any suitable facility with setup/facility for monitoring incoming/outgoing vessels meeting industry standards.

S No	Bidder name	S No as per bidder	Page no	Article no	Text provided in document	Queries with justification (if any)	IWAI response to bidders
109	HIPL	109	139	32, Annexure X	Monitoring Arrangement	Authority requested to change the frequency of issuance of such report to six months. Further, as the purpose of the Monitoring Report is to update the status of key milestones and obligations Authority should reduce this list comprising 36 items to list of maximum of 10 items consisting of the key KPIs relevant to inland waterways terminal	No change, bid conditions prevail
110	HIPL	110	142	32, Annexure X	Monitoring Arrangement: Compliance of Obligations of the Concessioneing Authority Grant approvals/ consents sought by the Concessionaire as required under the agreement	The obligation of Concessioanire should include Grant , obtaining and maintaining of approvals/ consents sought by the Concessionaire as required to perform its obligation under the agreement. Authority requested to modify the clause accordingly.	No change, bid conditions prevail

S No	Bidder name	S No as per bidder	Page no	Article no	Text provided in document	Queries with justification (if any)	IWAI response to bidders
111	HIPL	111	147	Annexure XI	<p>This Guarantee shall be unconditional and irrevocable and shall remain in full force and effect until Scheduled Project Completion Date and for a period of twelve months thereafter unless discharged/released earlier by the Board in accordance with the provisions of the Concession Agreement.</p>	<p>Please clarify as Clause 4.1 is not in line with this clause in Annexure XI. As per Clause 4.1 the Performance Guarantee shall be effective from COD till the end of the Concession Period whereas as per Annexure XI, the Performance Guarantee shall remain in full force and effect until Scheduled Project Completion Date and for a period of twelve months thereafter.</p> <p>Further, please provide definition of Scheduled Project Completion Date.</p> <p>It is advised that the Performance Gurantee should remain in force till the completion of the Terminal Equipment Phase and not for the enire Concession Period.</p>	Please refer amendment 13

S No	Bidder name	S No as per bidder	Page no	Article no	Text provided in document	Queries with justification (if any)	IWAI response to bidders
112	HIPL	112	151	Annexure XIII	Applicable Permits	Please also include Environmental Clearance, Forest Clearance and Consent to Establish (for both Air and Water) in the list of permits in Annexure XIII	No change, bid conditions prevail
113	HIPL	113	163	Annexure XIV	Proposed Schedule IV	<p>Please confirm that the Concessionaire is entitled to levy and collect all three category of charges defined in the Proposed Schedule IV i.e. Cargo Related Charges, Vessel Related Charges and Miscellaneous Charges</p> <p>As Concessionaire is responsible for providing Marine and Terminal Services (as per Clause 7.1.2) it should be entitled to collect the vessel related charges. Please confirm.</p>	Concessionaire shall be entitled to collect charges as given in proposed Schedule IV of Annexure XIV (of DCA)

S No	Bidder name	S No as per bidder	Page no	Article no	Text provided in document	Queries with justification (if any)	IWAI response to bidders
114	IRC	13	23	2.2.1	<p>The Concession hereby granted is for a period of 10 (ten) years commencing from the COD during which the Concessionaire is authorized and obliged to implement the Project and to provide Project Facilities and Services as per Scope of Work in accordance with the provisions hereof.</p> <p>Provided that:</p> <p>(a) In the event of the Concession being extended by the Concessions Authority beyond the said period of 10 (ten) years in accordance with the provisions of this Agreement, the Concession Period shall include the period by which the Concession is so extended, and</p> <p>(b) In the event of an</p>	<p>Due to high capital investment and other practical considerations regarding cargo and logistics development etc., request a concession period of 30 years with an option for first right of refusal thereafter. Kindly confirm.</p>	<p>No change, bid conditions prevail</p>

S No	Bidder name	S No as per bidder	Page no	Article no	Text provided in document	Queries with justification (if any)	IWAI response to bidders
					<p>early termination of this Agreement by either Party in accordance with the provisions hereof, the Concession Period shall mean and be limited to the period commencing from the COD and ending with the date of termination of this Agreement.</p>		

S No	Bidder name	S No as per bidder	Page no	Article no	Text provided in document	Queries with justification (if any)	IWAI response to bidders
115	IRC	14	26	3.1.1.(b) & (c)	<p>(b) Furnishing of copies (certified as true copies by a director of the Concessionaire) of the constituent documents of the Concessionaire;</p> <p>(c) Furnishing of all resolutions adopted by the Board of Directors of the Concessionaire (certified as true copies by a director of the Concessionaire) authorizing the execution, delivery and performance by the Concessionaire, of each of the Bidding Documents;</p>	<p>Does these Articles mean Board of Directors of SPV or the bidding company? Kindly clarify.</p>	<p>Power of Attorney shall have to be accorded by Board of Directors of bidding entity</p>

S No	Bidder name	S No as per bidder	Page no	Article no	Text provided in document	Queries with justification (if any)	IWAI response to bidders
116	IRC	15	30	4.1	<p>The Concessionaire shall for due performance of its obligations towards the Project as given in this Agreement provide to Concessions Authority an unconditional and irrevocable bank guarantee, within 15 (fifteen) days of execution of this Agreement, in favour of the Concessions Authority, encashable and enforceable at Noida, Uttar Pradesh, substantially in the form set forth in Annexure XI (the "Performance Guarantee"). The Performance Guarantee shall be for a sum of INR 4.8 crore (INR Four crore and eighty lakh</p>	<p>In view of several liquidated damages clause in various Articles (Article 7.6 etc.) of the agreement e.g. liability for shortfall of performance, it is requested Performance Guarantee for a sum of INR 2.0 crore be accepted instead of INR 4.8 crore. Kindly confirm.</p>	<p>No change, bid conditions prevail</p>

S No	Bidder name	S No as per bidder	Page no	Article no	Text provided in document	Queries with justification (if any)	IWAI response to bidders
					only) effective from COD till the end of the Concession Period.		

117	IRC	16	33	6.1.1	<p>The Concessionaire shall at its cost, charges and expenses, prepare the detailed technical report (the "DTR") including traffic study and operational design for Development/Equipment Works in conformity with the Scope of Work for the Terminal Equipment Phase.</p>	<p>The assumptions and basis for planning and designing for increasing capacity of terminal as per scope of work have to be finalised before a DTR could be prepared. As per Annexure XII of RFP, 2 nos. Mobile Harbour Cranes and 10 nos. Dumpers are required for a terminal capacity of 3.07 MMTPA whereas as per Annexure III : Scope of Work of DCA, 1 no. Mobile Harbour Crane and 10 nos. Dumpers are required for the above purpose. There are five alternative layouts with different cargo packages as given in the DPR. These aspects should be finalised to have a clarity of thoughts. Cargo, its source and associated logistics should be developed. Only after finalisation of the above, operational design for equipment etc. can be done. In view of the above, the time frame for preparing the DTR and</p>	No change, bid conditions prevail
-----	-----	----	----	-------	----------------------------------------------------------------------------------------------------------------------------------------------------------------------------------------------------------------------------------------------------------------------------	---------------------------------------------------------------------------------------------------------------------------------------------------------------------------------------------------------------------------------------------------------------------------------------------------------------------------------------------------------------------------------------------------------------------------------------------------------------------------------------------------------------------------------------------------------------------------------------------------------------------------------------------------------------------------------------------------------------------------------------------------------------------------------------------------------------------------------	-----------------------------------

						<p>execution of the work to attain capacity of 3.07 MMTPA as given in Clause 3 of Article 25 Annexure III - Scope of Work of DCA should be kept flexible which can be finalised by mutual discussion between concessionaire and concessioning authority in due course.</p>	
--	--	--	--	--	--	----------------------------------------------------------------------------------------------------------------------------------------------------------------------------------------------------------------------------------------------------------------------------	--

S No	Bidder name	S No as per bidder	Page no	Article no	Text provided in document	Queries with justification (if any)	IWAI response to bidders
118	IRC	17	34	6.3.1	<p>Terminal Equipment Phase</p> <p>The Concessionaire shall promptly commence and complete the works, including installation of equipment in accordance with the conditions of the Terminal Equipment Phase and shall also obtain from the Independent Engineer a certificate as to completion of development/equipment of Project Facilities and Services in accordance with provisions of this Agreement ("Completion Certificate") not later than 24 months from the date of commencement of the</p>	<p>Query given in Sr. No. 16 above should be considered.</p>	<p>No change, bid conditions prevail</p>

S No	Bidder name	S No as per bidder	Page no	Article no	Text provided in document	Queries with justification (if any)	IWAI response to bidders
					Terminal Equipment Phase.		

S No	Bidder name	S No as per bidder	Page no	Article no	Text provided in document	Queries with justification (if any)	IWAI response to bidders
119	IRC	18	35	6.5.2	<p>Obligations of the Concessioning Authority :</p> <p>make available all records of sub-soil investigations carried out on its behalf in the Terminal's Assets, if requested by the Concessionaire. It is clarified that the Concessionaire shall be solely responsible for determining the adequacy or otherwise of such investigations and will not in reliance of such records, be entitled to claim any relief under this Agreement.</p>	<p>Most of the Terminal Assets are at various stages of construction foundation of which must have been designed based on soil investigation report. In view of above, Concessionaire's responsibility for determining adequacy or otherwise of such investigation at this advanced stage of the project is not understood. Kindly clarify.</p>	<p>Concessionaire shall need to peruse reports of studies performed by Concessioning Authority. If additional information is required, Concessionaire shall perform its own studies.</p>

S No	Bidder name	S No as per bidder	Page no	Article no	Text provided in document	Queries with justification (if any)	IWAI response to bidders
120	IRC	19	39	6.9 liquidated damages at the rate of 0.1% (zero point one percent) of the Performance Guarantee for every day of delay in fulfilling specified obligations on or before a Milestone Date including a delay in obtaining the Completion Certificate or the Provisional Certificate on or before the Scheduled Project Completion Date.	0.1% of the Performance Guarantee for every day of delay appears to be high. Request LD should be on slabs e.g., beginning with INR 5000 for first week, INR 7500 for second week, INR 10000 for third week, INR 25000 for fourth week and so on. Kindly confirm.	No change, bid conditions prevail
121	IRC	20	41	7.1.2.(b)	Marine and Terminal Services : (b) Concessionaire share provide pilotage and towage services at the waterfront on the Project Site	These services could be hired. Kindly confirm,	Pilotage for berthing/unberthing for a stretch of 700 m on either side of quay from the central point shall be provided by Concessionaire as per tariff which will be notified as schedule IV on lines of Schedule III (Annexure XIV of Concession Agreement) Please also refer Article 12.1.6 of Draft Concession Agreement

S No	Bidder name	S No as per bidder	Page no	Article no	Text provided in document	Queries with justification (if any)	IWAI response to bidders
122	IRC	21	41	7.1.2.(d)	Marine and Terminal Services : (d) Provide office space of 500 (Five hundred) square feet for the Concessioning Authority within the Terminal Administrative Building	We understand from DPR, Terminal Administrative Building will be constructed by the Concessioning Authority. In view of this, kindly clarify.	Terminal Administrative Building shall be part of Terminal's Assets handed over to Concessionaire. Concessionaire shall provide office space for Concessioning Authority in the Terminal Administrative Building

123	IRC	22	43	7.1.12.(a)	<p>Minimum Guaranteed Cargo :</p> <p>The Concessionaire shall endeavor to achieve a minimum annual riverine cargo throughput as per below schedule starting from COD.</p>	<p>Since this is a new terminal and no past cargo data are available, committing minimum guaranteed cargo appears to be difficult.</p> <p>As per the DPR, Alternative 1 has been selected as the preferred Alternative for Haldia MMT which considers fly ash as the major cargo - 2.71 MTPA (88%) out of total cargo of 3.08 MTPA.</p> <p>IWAI has three existing jetties at Haldia for loading fly ash and one more jetty has been planned at Kolaghat. Loading of fly ash must be stopped at all the three Haldia jetties and the proposed Kolaghat jetty. Even then, we may fall short of targetted fly ash quantity.</p> <p>We, therefore, suggest that the operation be carried out for 10 years with 30 years concession period without any</p>	<p>No change, bid conditions prevail</p> <p>This is as per appraisal and approval of SFC</p>
-----	-----	----	----	------------	---------------------------------------------------------------------------------------------------------------------------------------------------------------------------	--------------------------------------------------------------------------------------------------------------------------------------------------------------------------------------------------------------------------------------------------------------------------------------------------------------------------------------------------------------------------------------------------------------------------------------------------------------------------------------------------------------------------------------------------------------------------------------------------------------------------------------------------------------------------------------------------------------------------------------------------------	----------------------------------------------------------------------------------------------

						<p>stipulation of minimum guaranteed cargo and, thereafter, this concept can be introduced based on mutual discussion on prevailing situation at that point of time. Kindly confirm.</p>	
--	--	--	--	--	--	------------------------------------------------------------------------------------------------------------------------------------------------------------------------------------------	--

S No	Bidder name	S No as per bidder	Page no	Article no	Text provided in document	Queries with justification (if any)	IWAI response to bidders
124	IRC	23	44	7.1.13	Indemnity against claims for loss of goods	The following clause should be added : "Consequential Damages : Notwithstanding any provision of the Contract to the contrary, neither party shall be liable to the other for any kind of special, incidental, indirect and/or consequential damages whatsoever, such as but not limited to loss of use, loss of profits, loss of production and contracts irrespective of the legal basis for any such claim."	No change, bid conditions prevail
125	IRC	24	45	7.1.16	Cargo visibility : The Concessionaire shall provide end-to-end visibility of cargo to all users by use of adequate technologies.	Kindly clarify.	As IWT entails multimodal transportation, cargo visibility is important from a cargo tracking perspective. Concessionaire shall operate necessary technological components (hardware and software) for providing tracking of cargo at the MMT to cargo owners and/or freight forwarders

S No	Bidder name	S No as per bidder	Page no	Article no	Text provided in document	Queries with justification (if any)	IWAI response to bidders
126	IRC	25	47	7.3.3	Maintenance of Least Available Depth : The Concessioneing Authority shall endeavour to provide the Least Available Depth ("LAD") along NW-1 as follows:	The draft at the floating jetty at Haldia Dock Complex for unloading barges is 8 m. Request LAD of 6/8 m be also maintained from Haldia Dock Complex to MMT Haldia to enable barges being unloaded at Haldia Dock Complex to come up to MMT, Haldia for unloading and subsequent onward despatch from MMT. This is expected to improve cargo availability at Haldia MMT considerably.	Historical hydrographic data has shown that LAD of 6m is found at Haldia MMT with some tidal variation.
127	IRC	26	48	7.5.1.(c)	The Concessionaire may, at its cost, make alternate arrangements for power including but not limited to installation of generators, subject to obtaining Applicable Permits, if any.	Since all utilities are being provided by the Concessioneing Authority, request installation of generators also be provided by them.	No change, bid conditions prevail

S No	Bidder name	S No as per bidder	Page no	Article no	Text provided in document	Queries with justification (if any)	IWAI response to bidders
128	IRC	27	49	8.1.2	The Ceiling Tariff shall be revised every year based on a variation in the Wholesale Price Index ("WPI"). Such revision shall be based on indexation against 60% (sixty percent) of the variation in the WPI for a relevant year beginning 1st January and ending 31st December.	A suitable diesel price variation clause should be included. Kindly confirm.	No change, bid conditions prevail
129	IRC	28	50	9.2.1 Such payments shall commence from 2nd (second) month (pertaining to previous month) after COD till the end of Concession Period or on termination whichever is earlier.	Request payment of Royalty to commence from end of 4th anniversary of COD in line with similar provision in the MMT Varanasi. Kindly confirm.	No change, bid conditions prevail

S No	Bidder name	S No as per bidder	Page no	Article no	Text provided in document	Queries with justification (if any)	IWAI response to bidders
130	IRC	29	58	12.1.3.(ii)	<p>Insurance :</p> <p>Insurance Cover & Insurance Companies: The Concessionaire shall insure all insurable Terminal's Assets and Project Facilities and Services and all insurable risks associated with Project to the extent advisable in accordance with Good Industry Practice ("Insurance Cover"). Insurance of IWAI assets to be taken with zero deductible franchise to ensure maximum proceeds.</p>	<p>We do not have insurable interest in Terminal's Assets procured and installed by IWAI and, as such, it is desirable that insurance of Terminal's Assets be arranged by IWAI. If, however, IWAI reimburses the insurance premium to us, we can arrange insurance with IWAI permission.</p>	<p>No change, bid conditions prevail</p>

S No	Bidder name	S No as per bidder	Page no	Article no	Text provided in document	Queries with justification (if any)	IWAI response to bidders
131	IRC	30	59	12.1.4	<p>Indemnification : The Concessionaire shall, during pendency of this Concession Agreement and thereafter, until all claims and demands in respect to acts and omissions during the Concession Period as described hereunder are duly settled, indemnify and keep indemnified and otherwise save harmless, the Concessions Authority, its agents and employees, from and against all claims, demands made against and/or loss caused and/or damages suffered and/or cost,</p>	<p>Following clause to be added : "Consequential Damages : Notwithstanding any provision of the Contract to the contrary, neither party shall be liable to the other for any kind of special, incidental, indirect and/or consequential damages whatsoever, such as but not limited to loss of use, loss of profits, loss of production and contracts irrespective of the legal basis for any such claim."</p>	No change, bid conditions prevail

S No	Bidder name	S No as per bidder	Page no	Article no	Text provided in document	Queries with justification (if any)	IWAI response to bidders
132	IRC	31	59/60	12.1.6	<p>Engagement of Contractors :</p> <p>The Concessionaire shall engage the Management Contractor and execute the Management Contract, thereby entrusting the Management Contractor with the responsibilities of operating and managing the Project Facilities and Services in the manner envisaged under the Request for Proposal. A copy of the Management Contract shall be provided to the Concessioning Authority and the same shall not be amended, substituted or revoked without prior written consent of the</p>	<p>Apart from Management Contractor, Operation & Maintenance Contractors, Fabrication Contractors, Original Equipment Manufacturers etc. have to be contracted for carrying out various jobs for smooth operation of the project. For removing any doubt, we seek a confirmation that this would be allowed as per this Article.</p>	No change, bid conditions prevail

S No	Bidder name	S No as per bidder	Page no	Article no	Text provided in document	Queries with justification (if any)	IWAI response to bidders
					Concessioneing Authority.		

S No	Bidder name	S No as per bidder	Page no	Article no	Text provided in document	Queries with justification (if any)	IWAI response to bidders
133	IRC	32	61	12.1.7.(b)	<p>Condition Survey : The Concessionaire shall as security for performance of its obligation in preceding sub-Article (a), submit to the Concessions Authority a guarantee issued by a scheduled bank in India for a sum of INR 4.8 crore (INR Four crore and eighty lakh only), 2 (two) years prior to the expiry of the Concession Period. In the event of Concessionaire's failure to provide such guarantee, the same shall be deemed to be a Concessionaire Event of Default and the Concessions Authority shall accordingly be entitled to terminate this Agreement in</p>	<p>Suggest one Performance Bank Guarantee under Article 4.1 should suffice as the bank guarantee amount would be continuously maintained by topping up any amount encashed as per Article 4.3. Kindly confirm.</p>	<p>No change, bid conditions prevail</p>

S No	Bidder name	S No as per bidder	Page no	Article no	Text provided in document	Queries with justification (if any)	IWA response to bidders
					accordance with Article 15. This shall be over and above the Performance Guarantee submitted in accordance with Article 4.		
134	IRC	33	69	14.4.1.(f)	Insufficient LAD on NW-1 for a period of 7 (seven) Days or more as communicated by the Authority through a public notification.	This is contrary to Annexure IV of DCA : Performance Standards and damages : Calculation of penalty in loss of shortfall in LAD maintenance. Kindly clarify.	LAD shortfall for a period less than 7 days (after establishment of case) shall not be Force Majeure

S No	Bidder name	S No as per bidder	Page no	Article no	Text provided in document	Queries with justification (if any)	IWAI response to bidders
135	IRC	34	72	15.1.1.(v)	<p>The Concessionaire Event of Default :</p> <p>Concessionaire's failure to perform or discharge any of its obligations under any other Project Contract, which has or is likely to affect the Project/the Project Facilities and Services, materially;</p>	Kindly clarify.	Material default for any contract (including contracts wherein Concessioning Authority is not a signing party) having a bearing on EOT agreement may be construed as event of default for EOT Agreement

S No	Bidder name	S No as per bidder	Page no	Article no	Text provided in document	Queries with justification (if any)	IWAI response to bidders
136	IRC	35	72	15.1.1.(vi)&(vii)	<p>(vi) Concessionaire fails to achieve Minimum Guaranteed Cargo for a consecutive period of 3 (three) years starting 11th (eleventh) onwards, in the event that Concession Period is extended by 5 (five) years. Provided, the Concessionaire shall not be deemed to be in default if such non achievement is due to a substantial change in economic policies including the policy regarding import/export of a particular commodity as a result of which the throughput could not be achieved;</p> <p>(vii) Minimum annual riverine cargo throughput as per Article 7.1.12 is not</p>	<p>Since this is a new terminal and no past cargo data are available, committing minimum guarantee cargo appears to be difficult. We suggest that the operation be carried out for 10 years with 30 years concession period without any stipulation of minimum guaranteed cargo and, thereafter, this concept can be introduced based on mutual discussion on prevailing situation at that point of time. Kindly confirm.</p>	<p>No change, bid conditions prevail</p>

S No	Bidder name	S No as per bidder	Page no	Article no	Text provided in document	Queries with justification (if any)	IWAI response to bidders
					met in at least 3 (three) years between the 4th (fourth) year and 8th (eighth) year of Concession Period;		

S No	Bidder name	S No as per bidder	Page no	Article no	Text provided in document	Queries with justification (if any)	IWAI response to bidders
137	IRC	36	79	16.5.2	Notwithstanding anything contained in this Concession Agreement, except for ensuring the deposit of the compensation payable to the Concessionaire in accordance with Article 17 in the Escrow Account, the Concessioning Authority shall not, as a consequence of termination or otherwise, have any obligation whatsoever to any third party including but not limited to obligations as to compensation for loss of employment,	The following clause should be added : "Consequential Damages : Notwithstanding any provision of the Contract to the contrary, neither party shall be liable to the other for any kind of special, incidental, indirect and/or consequential damages whatsoever, such as but not limited to loss of use, loss of profits, loss of production and contracts irrespective of the legal basis for any such claim."	No change, bid conditions prevail

S No	Bidder name	S No as per bidder	Page no	Article no	Text provided in document	Queries with justification (if any)	IWAI response to bidders
138	IRC	A6	163	Annexure XIV :	Proposed Schedule IV	We assume that all the service charges listed in proposed Schedule IV including terminal charges, vessel related charges, storage charges in warehouse and open yard, miscellaneous charges etc. would be collected by the Commissionaire which would constitute their revenue. Kindly clarify.	Tariffs mentioned in proposed tariff schedule IV shall be collected by Concessionaire as part of Concessionaire revenue

S No	Bidder name	S No as per bidder	Page no	Article no	Text provided in document	Queries with justification (if any)	IWAI response to bidders
139	IRC	A7	164	Annexure XIV :	Item v .(b).(i) : Fly Ash : Composite charge for loading/unloading on to vessel by pneumatic means, movement to yard or truck and loading/unloading on/from Truck : Rs. 45 per MT	<p>Considering the O & M cost estimate given in the DPR, the rate of Rs.45 per MT appears to be low. Also, table 18.6 of DPR (page 382) reveals that a modest IRR of 6.40% was based on a much higher cargo handling rate. For Haldia MMT, Fly Ash appears to be a major cargo. Also, we have to pay "Royalty" to the Concessioning Authority from this revenue.</p> <p>In view of the above considerations, there appears to be scope for reviewing the handling charges of Fly Ash.</p> <p>Clarification solicited.</p>	Bidder may indicate suitable numerical modification for the tariff as per format shared in Corrigendum 4 to the tender documents.
140	Five Star Logistics	1	16	1	Non-riverine cargo means cargo other than Riverine Cargo. Quantities of such cargo will be ascertained as	Please clarify in detail what is meant by this with description if possible	If either (or both) incoming and outgoing cargo logistics is through inland waterway transportation for a cargo parcel, the parcel shall be considered as riverine cargo

S No	Bidder name	S No as per bidder	Page no	Article no	Text provided in document	Queries with justification (if any)	IWAI response to bidders
					per Goods Receipt document.		
141	Five Star Logistics	2	16	1	Riverine cargo means cargo transported to and/or from the Terminal through waterways. For the avoidance of doubt, it is clarified that in the event cargo imported into the Terminal has been processed and exported, such cargo shall be treated as Riverine Cargo in the event either the import or export is through waterways.	Please clarify in detail what is meant by this with description if possible Will cargo lighterage from Sandheads / Sagar / Other Lighterage points be allowed at the Terminal	Response to this query shall be shared in second set of responses to pre-bid queries.
142	Five Star Logistics	3	32	5.7	The costs and expenses of the Independent Engineer and Independent Surveyor for their services shall be borne by the Concessioning	What are the expected annual costs for the Independent Engineer and Independent Surveyor	Bidders are encouraged to perform their own due diligence regarding costs

S No	Bidder name	S No as per bidder	Page no	Article no	Text provided in document	Queries with justification (if any)	IWAI response to bidders
					Authority and Concessionaire, equally.		
143	Five Star Logistics	4	36	7.1. 12.c	In the event that minimum annual riverine cargo throughput is not met as per slabs in Article 7.1.12 (a) in at least 3 (three) years between the 4th (fourth) year and 8th (eighth) year of concession, it shall be considered as case for Termination of contract as a Concessionaire Event of Default.	Please confirm that during initial Concession Period of 10 years, the failure to achieve MGT will not require the Concessionaire to pay Royalty for the shortfall quantity in achieving MGT.	<ul style="list-style-type: none"> i. Till 10th year, Concessionaire shall pay Royalty based on actual throughput only ii. MGC achievement to be monitored for Concession Period extension request iii. If MGC slabs are not met in at least 3 years between 4th and 8th year of concession it shall be a case for Concessionaire Event of Default

S No	Bidder name	S No as per bidder	Page no	Article no	Text provided in document	Queries with justification (if any)	IWAI response to bidders
144	Five Star Logistics	5	38	7.2.1	<p>Preferential and priority berthing The Concessionaire shall manage and operate Project Facilities and Services on a 'first come - first serve', common-user basis, open to any and all barge operators, importers, exporters, shippers, consignees and receivers; and refrain from indulging in any unfair or discriminatory practice against any user or potential user thereof. However, if there is a requirement to offer preferential or priority berthing to any one or more barge operators or vessel owners/operators to optimize the use of Project Facilities and Services, it shall be done based on volume</p>	<p>Since the Concessionaire is responsible for fulfilling MGT. Hence the Concessionaire should be allowed to have his own priority norms and strategies to attract cargo and not solely on the grounds of volume commitment only</p>	<p>Concessionaire shall have the option of offering priority berthing to clients basis volume commitments</p>

S No	Bidder name	S No as per bidder	Page no	Article no	Text provided in document	Queries with justification (if any)	IWAI response to bidders
					commitments from the Concessionaire's client.		

S No	Bidder name	S No as per bidder	Page no	Article no	Text provided in document	Queries with justification (if any)	IWAI response to bidders
145	Five Star Logistics	6	40	7.6.1	<p>In the event the Concessioneing Authority, whether from the review of reports submitted by the Concessionaire or otherwise, observes that Project Facilities and Services fall short of the Performance Standards, the Concessioneing Authority shall issue a demand notice to the Concessionaire seeking liquidated damages. The liquidated damages shall be calculated in accordance with Annexure IV of this Agreement. The liquidated damages shall be payable within 30 (thirty) days of the date of issue of notice. On failure of the Concessionaire to pay the same,</p>	<p>The basis for arriving at the Threshold parameters given at Annexure IV against which performance will be evaluated may be clarified. Besides, these parameters appear to be stiff. Hence these may be reviewed.</p>	<p>No change, bid conditions prevail</p>

S No	Bidder name	S No as per bidder	Page no	Article no	Text provided in document	Queries with justification (if any)	IWA response to bidders
					Concessioneing Authority shall recover the amount from the Performance Bank Guarantee provided by the Concessionaire.		
146	Five Star Logistics	7	41	8.1.1	The Concessionaire shall levy and recover Tariff from the users of the Project Facilities and Services as per Annexure XIV. The tariff document as per Annexure XIV prescribes the maximum tariff that can be levied by the Concessionaire ("Ceiling Tariff").	Please mention clearly which tariffs the Concessionaire will be authorised to charge out of all the charges given in different schedules at Annexure XIV for providing different services under this project.	Please refer Annexure XIV of Draft Concession Agreement

S No	Bidder name	S No as per bidder	Page no	Article no	Text provided in document	Queries with justification (if any)	IWAI response to bidders
147	Five Star Logistics	8	43	7.1.10	The Concessionaire may make his own arrangements for security of Project Site and Terminal Assets. The Concessionaire shall abide by the security regulations and procedures prescribed by the Concessioneing Authority or a competent Government Concessioneing Authority from time to time.	What are the security regulations and procedures currently prescribed. Please provide a copy	Security arrangements may be made as per Applicable Law
148	Five Star Logistics	9	45	7.1.16	The Concessionaire shall provide end-to-end visibility of cargo to all users by use of adequate technologies.	Please clarify what is meant by this and how this is to be done	As IWT entails multimodal transportation, cargo visibility is important from a cargo tracking perspective. Concessionaire shall operate necessary technological components (hardware and software) for providing tracking of cargo at the MMT to cargo owners and/or freight forwarders

S No	Bidder name	S No as per bidder	Page no	Article no	Text provided in document	Queries with justification (if any)	IWAI response to bidders
149	Five Star Logistics	10	49	8.1.1	The Concessionaire shall levy and recover Tariff from the users of the Project Facilities and Services as per Annexure XIV. The tariff document as per Annexure XIV prescribes the maximum tariff that can be levied by the Concessionaire (Ceiling Tariff).	Please clarify what all charges are to be collected by the successful bidder and what charges are to be retained by the successful bidder and what charges are to be collected on behalf of IWAI	Please refer Annexure XIV of Draft Concession Agreement
150	Five Star Logistics	11	49	8.1.2	The Ceiling Tariff shall be revised every year based on a variation in the Wholesale Price Index (WPI). Such revision shall be based on indexation against 60% (sixty percent) of the variation in the WPI for a relevant year beginning 1st January and ending 31st December.	Please clarify the date of notification of the tariff From what date will WPI indexation be considered	Ceiling tariff will be notified by IWAI as per mutual agreement between IWAI and bidders Ceiling tariff will be indexed to 60% of variation in WPI annually Details on reference dates for WPI are mentioned in Article 8.1.2 of Draft Concession Agreement

S No	Bidder name	S No as per bidder	Page no	Article no	Text provided in document	Queries with justification (if any)	IWAI response to bidders
151	Five Star Logistics	12	49	8.1.3	The revised Ceiling Tariff shall be regulated as per Section 17 of the Inland Waterways Authority Act, 1985. Such revised Ceiling tariff will become applicable after the same has been notified by the Concessioneing Authority.	If the Tariff is not notified before the readiness of commencement of operations at the terminal what will be the consequences of the same	<ul style="list-style-type: none"> i. Indicative ceiling tariff provided in proposed tariff schedule in Annexure XIV of DCA ii. Modifications, if any, to be mutually agreed between IWAI and potential bidders iii. Updated tariff schedule with modified ceiling tariff shall be notified by IWAI iv. Ceiling tariff will be indexed to 60% of variation in WPI annually

S No	Bidder name	S No as per bidder	Page no	Article no	Text provided in document	Queries with justification (if any)	IWAI response to bidders
152	Five Star Logistics	13	50	9.2.1	<p>Payments of Royalty The Concessionaire shall pay to the Authority Royalty equal to INR ___per MT on Riverine cargo handled during the previous month (Royalty). Such payments shall commence from 2nd (second) month (pertaining to previous month) after COD till the end of Concession Period or on termination whichever is earlier. The Concessionaire shall also make payments to the Concessions Authority an amount equivalent to the quoted Royalty plus a premium of 20% (twenty percent) on quoted Royalty for Non-Riverine cargo handled during the previous month. Such</p>	<p>After COD the equipment implementation phase is 24 months Please clarify how Royalty payment can start from 2nd month after COD</p>	<p>On a monthly basis, Concessionaire shall pay Royalty for cargo handled in the previous month.</p> <p>In 2nd month after COD, Concessionaire shall pay Royalty for cargo handled in 1st month after COD.</p>

S No	Bidder name	S No as per bidder	Page no	Article no	Text provided in document	Queries with justification (if any)	IWA response to bidders
					<p>payments shall commence from 2nd (second) month (pertaining to previous month) after COD till the end of Concession Period or on termination whichever is earlier. All such payments shall be exclusive of applicable taxes which the Concessionaire will pay over and above Royalty payments.</p>		

S No	Bidder name	S No as per bidder	Page no	Article no	Text provided in document	Queries with justification (if any)	IWAI response to bidders
153	Five Star Logistics	14	262	4.4	<p>Petroleum products and Edible oil (in drums)</p> <p>Petroleum products in drums shall be coming to the terminal in barges which will be unloaded onto the berth using mobile harbour crane. The unloaded drums will be loaded onto trucks using forklifts and will be transported to the storage yard. Then it will be unloaded from trucks using forklifts and stored in the storage yard. Later, the drums will be loaded onto the trucks using forklift and transported to the hinterland. It is to be noted that edible oil being the export commodity, reverse handling process will be followed.</p>	<p>If the Successful Bidder wishes to make arrangements to handle liquid cargo by pipeline directly to and from vessel directly please confirm that there is no restriction on the same and that no prior permission will have to be take from KoPT or IWAI for making arrangement for the same.</p> <p>Please also confirm that what the traiff for handling liquid cargo by pipeline will be.</p>	Please refer Annexure III of Draft Concession Agreement

S No	Bidder name	S No as per bidder	Page no	Article no	Text provided in document	Queries with justification (if any)	IWAI response to bidders
154	Five Star Logistics	1				Please clarify if IWAI is giving any cargo exclusivity to this terminal and for what period	No cargo exclusivity to Haldia MMT
155	Five Star Logistics	2				Please clarify if IWAI will set up / come up / allow / give license for with any similar competing facility	IWAI has no plans of constructing any new facility in vicinity of Haldia MMT
156	Five Star Logistics	3				Please clarify if KoPT will set up / come up / allow / give license for with any similar competing facility	IWAI is not aware of any plan of KoPT for construction of new facility in vicinity of Haldia MMT
157	Five Star Logistics	5				Is there any restriction / arrangement with Kolkata Port Trust regarding handling of Vessels / Cargo at the terminal	Response to this query shall be shared in second set of responses to pre-bid queries.
158	Five Star Logistics	6				Environmental Clearance granted or not If not – status of application If yes – copy of clearance	Please refer Annexure 7 (of this document)

S No	Bidder name	S No as per bidder	Page no	Article no	Text provided in document	Queries with justification (if any)	IWAI response to bidders
159	Five Star Logistics	7				Does International Ship and Port Facility Security (ISPS) Code need to be followed If yes - please confirm if no - what code to be followed	Concession shall be monitored as per Applicable Law
160	Five Star Logistics	8				Does Safety of Life at Sea (SOLAS) Code need to be followed	Concession shall be monitored as per Applicable Law
161	Five Star Logistics	9				Does Convention for Prevention of Marine Pollution (MARPOL) Code need to be followed	Concession shall be monitored as per Applicable Law
162	Five Star Logistics	10				Does Customs need to be posted at the terminal Who will provide for the same IWAI or Successful Bidder Who will be paying for the same and what is the expected annual cost	Preventive Department of Customs shall be stationed at the Terminal Cost of Customs facility shall not be borne by IWAI
163	Five Star Logistics	11				Will Terminal Operating System (TOS) provided by IWAI or is it to be arranged by Successful Bidder	Terminal Operation System shall not be provided by Concessioneing Authority

S No	Bidder name	S No as per bidder	Page no	Article no	Text provided in document	Queries with justification (if any)	IWAI response to bidders
164	Five Star Logistics	12				Who will be responsible for calling of vessels to the terminal.	Bidders are encouraged to perform their own due diligence
165	Five Star Logistics	13				Will River Pilots be required for bringing vessels from Sagar to the Terminal What size of vessels will require River Pilots Will vessels calling at the terminal be awarded any priority.	Bidders are encouraged to perform their own due diligence Please refer Article 7.1.2. of Draft Concession Agreement
166	Five Star Logistics	14				What types of vessels which can be handled – Foreign / Coastal / IWT /	Response to this query shall be shared in second set of responses to pre-bid queries.
167	Five Star Logistics	15				What is the maximum Beam / LOA/ DWT of vessel that can be handled at the terminal	Channel width at Terminal shall be 45 m
168	Five Star Logistics	16				Loading & Unloading of what categories of vessels is allowed at the terminal	Inland vessels, coastal vessels and river sea vessels

S No	Bidder name	S No as per bidder	Page no	Article no	Text provided in document	Queries with justification (if any)	IWAI response to bidders
169	Five Star Logistics	17				What cargos are allowed to be handled at the Terminal	Concessionaire shall be permitted to handle riverine and non-riverine cargo at the Terminal
170	Five Star Logistics	18				What cargos are not allowed to be handled at the terminal	Concessionaire shall be permitted to handle riverine and non-riverine cargo at the Terminal
171	Five Star Logistics	19				No equipment of Rake Loading / Unloading has been provided in the DPR What is the plan for loading and unloading of rakes	Separate engineering studies have been performed for Railway connectivity Railway equipment shall not lie under purview of EOT concessionaire
172	Five Star Logistics	20				Will the successful bidder be allowed to set up a Container Freight Station (CFS) at the terminal	Concessionaire shall be permitted to handle riverine and non-riverine cargo at the Terminal

S No	Bidder name	S No as per bidder	Page no	Article no	Text provided in document	Queries with justification (if any)	IWAI response to bidders
173	Five Star Logistics	21				<p>What is the proposed draft at the terminal</p> <p>Will any dredging be required to achieve this</p> <p>If required when will the dredging be completed</p> <p>Who will be responsible for maintaining the draft</p> <p>Can the successful tenderer increase the draft at the terminal and in the turning circle to accommodate larger vessels</p>	<p>Concessioneing Authority shall endeavour to maintain LAD at channel, berth pockets, adequate turning circle as per Article 7.3.3 of DCA</p>
174	Five Star Logistics	22				<p>What is the projected date for completion of Railway Line and Siding</p> <p>If it is not completed by the projected date what are the consequences since the cargo throughput will be reduced for the successful bidder.</p>	<p>Railway layout plan completed by M/s RITES in consultation with Southern Railway</p> <p>Railway connectivity development shall be completed with 24 months of awarding EPC contract for the same</p>

S No	Bidder name	S No as per bidder	Page no	Article no	Text provided in document	Queries with justification (if any)	IWAI response to bidders
175	Five Star Logistics	23				<p>IWAI is currently operating 3 other jetties in Halida Port for loading of Fly Ash</p> <p>What will be the position of these jetties after the commissioning of this terminal</p> <p>Will they continue to operate or will they cease to operate</p> <p>What will happen to the private operators currently operating these terminals</p> <p>What happens if these private operators continue to operate</p>	<p>Fly ash handling at floating jetties (in vicinity of Haldia MMT) shall be discontinued prior to Commercial Operation Date</p>
176	Five Star Logistics	24				<p>Could you please provide a copy of the Hydrography Chart between the proposed IWAI Terminal and the Haldia Port Lock Gate</p>	<p>Please refer Annexure 9 (of this document)</p>

177	OSL	7	105	26	<p>The Concessing Authority shall be liable for penalty to the Concessionaire at a specific location/stretch in event of LAD shortfall discovered by unsuccessful passage of vessel through waterway as certified/ validated by the Independent Surveyor. The Concessing Authority shall be liable for such penalty only in stretches upstream of Tribeni which is located at a chainage distance of 193 km on National Waterway-1. For avoidance of doubt, it is stated that the Concessing Authority shall not be liable for such penalty in stretches downstream of Tribeni. The Concessing Authority shall also be liable for such penalty in the 7 km long connecting channel</p>	<p>As IWAI is responsible for the dredging of the approach channel of 7 km connecting between the terminal and National Waterways, please advise the route map which will be used to connect with. The approach channel of Haldia MMT for which the LAD of 3 m is to be maintained the cost of dredging and maintenance the depth in the channel and a depth of 4 m on the Berth /Terminal and the channel marking is to be carried out by IWAI / Kopt at their time and cost without putting any restriction on the movement of vessels to and fro from the terminal ? for the tenure of this tender</p>	<p>Concessing Authority shall endeavour to maintain LAD at channel, berth pockets, adequate turning circle as per Article 7.3.3 of DCA</p>
-----	-----	---	-----	----	----------------------------------------------------------------------------------------------------------------------------------------------------------------------------------------------------------------------------------------------------------------------------------------------------------------------------------------------------------------------------------------------------------------------------------------------------------------------------------------------------------------------------------------------------------------------------------------------------------------------------------------------------------------------------------------	-----------------------------------------------------------------------------------------------------------------------------------------------------------------------------------------------------------------------------------------------------------------------------------------------------------------------------------------------------------------------------------------------------------------------------------------------------------------------------------------------------------------------------------------------------------------------------------------------------------	--------------------------------------------------------------------------------------------------------------------------------------------

				<p>between the Terminal and National Waterway-1.</p> <p>Independent Surveyor shall validate/ certify that unsuccessful passage is not due to Concessionaire default subject to the following conditions:</p> <p>i. Concessionaire has taken an informed decision about the size and draft of the vessel and volume of cargo that can pass through National Waterway-1 by duly checking the LAD information updated periodically by the Authority on their website or any other source of information used in the future.</p> <p>ii. Concessionaire has adhered to the National Waterway-1 channel as declared by the Authority in their</p>		
--	--	--	--	---------------------------------------------------------------------------------------------------------------------------------------------------------------------------------------------------------------------------------------------------------------------------------------------------------------------------------------------------------------------------------------------------------------------------------------------------------------------------------------------------------------------------------------------------------------------------------------------------------------------------------------------	--	--

					navigation charts updated periodically.		
--	--	--	--	--	--------------------------------------------	--	--

S No	Bidder name	S No as per bidder	Page no	Article no	Text provided in document	Queries with justification (if any)	IWAI response to bidders
178	OSL	8	283	6.2.1.2	Table 6.3 Dredge depths required Table 6.3 Dredge depths required Description Barge Draft (m) 2.5 Under keel clearance (@20%) (m) 0.5 Allowance for siltation (m) 1 Channel depth required (m) 4 Tidal window (MLWS) (m) 0.8 Dredge level below CD 3.2		Concessioning Authority shall endeavour to maintain LAD at channel, berth pockets, adequate turning circle as per Article 7.3.3 of DCA
179	Ripley	1	1.1	Definition		“Exclusivity Period” shall have the meaning ascribed to it in Article 12.2.2. It may be noted that the Clause -12.2.2 referred under definition of Exclusivity Period is not relevant with the Exclusivity Period	Please refer amendment 4

S No	Bidder name	S No as per bidder	Page no	Article no	Text provided in document	Queries with justification (if any)	IWAI response to bidders
180	Ripley	2		PERMITS AND CLEARANCES		Kindly provide the list of applicable Clearances/Permits to be obtained by Concessioneing Authority and Concessionaire to be mentioned clearly.	Permits/Clearances already obtained shall be shared with Concessionaire IWAI shall assist Concessionaire in obtaining additional permits/clearance All permits/clearances shall be maintained by Concessionaire

S No	Bidder name	S No as per bidder	Page no	Article no	Text provided in document	Queries with justification (if any)	IWAI response to bidders
181	Ripley	3	7.1.12	Minimum Guaranteed Cargo		<p>We refer that the MGC given in the article has been set higher as compared to the potential of the cargo traffic which is possible to commit for the proposed IWT terminal. MGC provision is only for the purpose of invoking the Event of Default and there is no compensatory payment for revenue share due to shortfall in achieving the MGC. Hence there is no point in setting the high MGC. We suggest that the MGC numbers should be revised as follows:</p> <p>SN Period from the date of MGT (Million Tons per commencement of annum)</p> <p>commercial operation</p> <p>1 0 to 5 years 0.614 (20% of capacity)</p> <p>2 6 to 10 years 1.535 (50% of capacity)</p>	No change, bid conditions prevail

S No	Bidder name	S No as per bidder	Page no	Article no	Text provided in document	Queries with justification (if any)	IWAI response to bidders
						3 11 years onward 2.149 (70% of capacity)	

S No	Bidder name	S No as per bidder	Page no	Article no	Text provided in document	Queries with justification (if any)	IWAI response to bidders
182	Ripley	4	Annexure III:	Scope of Work		<p>Operation and Maintenance Operation and maintenance of the terminal's assets as mentioned in Annexure II handed over to the Concessionaire by the Concessioneing Authority in accordance with the provisions of this Agreement, applicable laws and applicable permits. Kindly confirm whether the maintenance of terminal's assets handed over to the Concessionaire can be outsourced to any other company.</p>	Please refer Article 12.1.6 of Draft Concession Agreement.
183	Ripley	5		General		<p>Kindly confirm that what will be the strategy of IWAI regarding existing IWAI jetties at Patikhali for loading Fly Ash to the Barges.</p>	Fly ash handling at floating jetties (in vicinity of Haldia MMT) shall be discontinued prior to Commercial Operation Date

S No	Bidder name	S No as per bidder	Page no	Article no	Text provided in document	Queries with justification (if any)	IWAI response to bidders
184	Ripley	6		General		Kindly confirm the specification like LOA, DWT etc. of the Barges can be accommodated at the proposed MMT IWT at Haldia	Channel width at Terminal shall be 45 m Further details are available in DPR
185	Ripley	7		General		Kindly confirm that whether transshipped/ lighterage cargo can be handled at the proposed MMT IWT at Haldia. If yes, any charges we have to pay directly to the Port authority.	Response to this query shall be shared in second set of responses to pre-bid queries.
186	Ripley	8		General		Kindly confirm the draft at jetty pocket of the proposed Terminal & Channel.	Concessioning Authority shall endeavour to maintain LAD at channel, berth pockets, adequate turning circle as per Article 7.3.3 of DCA
187	Ripley	9		General		Kindly share the traffic report by M/s Hamburg Port Consulting GmbH and M/s Universal Transport Consultancy GmbH for the proposed MMT terminal.	Please refer Annexure 6 (of this document).

S No	Bidder name	S No as per bidder	Page no	Article no	Text provided in document	Queries with justification (if any)	IWAI response to bidders
188	Ripley	10	6.2.1.4	Channel Length		Kindly provide the drawing of the approach channel which is approximately about 7.00 km.	Please refer Annexure 10 (of this documents)
189	Ripley	11		General		Kindly share the copy of Environment Clearance of the proposed MMT	Please refer Annexure 7 (of this document).
190	Ripley	12		General		It is seen from the similar RFP of Varanasi Terminal that there is a provision of payment of Royalty by the Concessionaire after 4th years of the COD. It is requested to implement the similar Clause of Royalty payment in Haldia MMT to increase the viability of the project.	No change, bid conditions prevail
191	HIPL	AA6	28	3.3.31	The aforesaid Conditions Precedent shall be complied within 90 (Ninety) days of the Appointed Date.	Please confirm that conditions precedent mentioned in Article 3.1.2 need not be complied within 90 days of the Appointed Date.	As mentioned in Article 3.1.2 of Draft Concession Agreement, conditions precedent for Terminal Equipment Phase shall be satisfied no later than 60 days prior to the start of development/equipment works

S No	Bidder name	S No as per bidder	Page no	Article no	Text provided in document	Queries with justification (if any)	IWAI response to bidders
192	HIPL	AA7	98	Annexure II	Item No. 18: Conveyors, Silos, Transfer Towers, Electrical, Automation, Fire Fighting, Barge Loader	Please clarify the automation systems that would be provided by Concessioning Authority as part of Terminal's Assets.	Please refer Annexure II of Draft Concession Agreement
193	HIPL	AA8	101	Annexure IV	Calculation of penalty in case of shortfall in LAD maintenance: The Concessioning Authority shall be liable for such penalty only in stretches upstream of Tribeni which is located at a chainage distance of 193 km on National Waterway-1.	Authority requested to share the historical LAD for previous 3 years downstream of Tribeni upto Haldia including LAD at Haldia MMT.	Please refer Annexure 11 (of this document)
194	HIPL	AA1	-	-	It was stated in the pre bid meeting held on Jul 10,2020 that IWAI would cease operations at its 3 existing jetties at Haldia.	Please confirm that the cessation of operations at the existing operational IWAI jetties would be a condition precedent of the Concessioning Authority prior to the Commercial Operation Date for the Haldia MMT	Fly ash handling at floating jetties (in vicinity of Haldia MMT) shall be discontinued prior to Commercial Operation Date

S No	Bidder name	S No as per bidder	Page no	Article no	Text provided in document	Queries with justification (if any)	IWAI response to bidders
195	HIPL	AA2	-	-	Charges payable to KoPT	Please advise on the various charges (wharfage, pilotage etc) that are payable to KoPT by vessels (foreign flagged or otherwise) plying to or from the Haldia MMT.	Response to this query shall be shared in second set of responses to pre-bid queries.
196	HIPL	AA3	-	-	Tariff at existing operational IWAI jetties at Haldia	Please share the current applicable scale of rates at the existing operational IWAI jetties at Haldia.	Please refer Schedule I and Schedule II of Tariff Regulations
197	HIPL	AA4	-	-	Customs	Please advise on the custom clearance facility at the terminal	Haldia is a notified Port of Call under PIWT&T and therefore, Customs facilities shall be provided as in the cases of other riverine Ports of Call. can be used for transshipment purposes as well.

S No	Bidder name	S No as per bidder	Page no	Article no	Text provided in document	Queries with justification (if any)	IWAI response to bidders
198	ICT				<p>Clause 1.1 (Page 11) “Total Project Cost” means the lowest of – (a) The capital cost of the Project for Concessionaire as set forth in the Financial Package including capital cost incurred by Concessionaire for development/equipment of Terminal infrastructure (b) The actual capital cost of the Project for Concessionaire upon completion including capital cost incurred by Concessionaire for development/equipment of Terminal infrastructure (c) A sum of INR 47.5 crore (INR Forty seven crore and fifty lakh) only</p> <p>Article 3 Clause 3.1.1 (i) Insurance requirement: The Concessionaire</p>	<ul style="list-style-type: none"> · Total Project Cost may increase due to reasons beyond the Concessionaire control. Considering that the financial risk is carried by the Concessionaire, the “lowest” may be changed to “Highest”. · The proposed project will be given under O&M contract and for O&M contracts all insurances are maintained by the Authority. Therefore, necessary corrections may be made to the DCA. 	No change, bid conditions prevail

S No	Bidder name	S No as per bidder	Page no	Article no	Text provided in document	Queries with justification (if any)	IWAI response to bidders
					shall, at its cost and expense, purchase and maintain insurances as are prudent....		
199	ICT				Clause 3.1.2 (b) (Page 19) & Clause 6.4.4 Obtaining "Applicable Permits" as may be required for commencement of Expansion Phase as set out in Annexure XIII. Obtain Applicable Permits, comply with	<ul style="list-style-type: none"> · Obtaining Environment Clearance, Approval from Central Empowered Committee shall be the responsibility of the Concessioneing Authority. Kindly confirm. 	<ul style="list-style-type: none"> i. Permits/Clearances already obtained shall be shared with Concessionaire ii. IWAI shall assist Concessionaire in obtaining additional permits/clearance iii. All permits/clearances shall be maintained by Concessionaire

S No	Bidder name	S No as per bidder	Page no	Article no	Text provided in document	Queries with justification (if any)	IWAI response to bidders
					Applicable Laws and Applicable Permits and give priority to safety in its development/ equipment and planning activities in order to protect life, health, property and environment;		
200	ICT				Article 5 (Page 31) Independent Engineer and Independent Surveyor Clause 5.6 (a) Concessionaire has taken an informed decision about the size of the vessel and volume of cargo that can pass through the waterway by checking the LAD information updated weekly by the Authority on their website or any other source of information used in the future. (b) Concessionaire has	<ul style="list-style-type: none"> · Concessionaire is responsible for the operations, maintenance, management and development of the terminal and in no case, shall be responsible for the unsuccessful passage of the vessels through the channel, therefore 5.6 may be deleted. · The Independent Surveyor may not be required on full time basis. It is requested to have a panel of surveyors with pre-determined rate 	Please refer amendment 6.

S No	Bidder name	S No as per bidder	Page no	Article no	Text provided in document	Queries with justification (if any)	IWAI response to bidders
					<p>adhered to the waterway channel as declared by the Authority in their navigational charts updated periodically.</p>	<p>contracts. Independent Surveyors may be appointed on case to case basis depending on the availability of the surveyors.</p>	

S No	Bidder name	S No as per bidder	Page no	Article no	Text provided in document	Queries with justification (if any)	IWAI response to bidders
201	ICT				<p>Clause 7.1.9 (Page 35) The Concessionaire shall install, operate and maintain such computer system and network (such as Electronic Data Interchange and Terminal Community System) and follow such protocol as the Concessioning Authority may specify from time to time. Clause 7.3.4 The Terminal Community System would be developed by the Concessioning Authority.</p>	<ul style="list-style-type: none"> · We understand that Authority is developing PCS for Inland Waterways and terminal community system will be part of this PCS which is being developed by the authority. · It is requested to give clarity on the above and suggest who will be responsible for developing the terminal community system – Concessionaire or Concessioning Authority. · What happens to the TCS etc after the expiry of the Concession Period. 	<p>Concessioning Authority shall be responsible for development of Terminal Community System</p> <p>All other responsibilities in this regard shall be of Concessionaire</p> <p>As per Article 18.2.4 of Draft Concession Agreement, it shall be an obligation of the Concessionaire to "transfer technology and up-to-date know-how relating to operation and maintenance of the Terminal's Assets and/or the Project Facilities and Services" to the Concessioning Authority at the end of concession period</p>

S No	Bidder name	S No as per bidder	Page no	Article no	Text provided in document	Queries with justification (if any)	IWAI response to bidders
202	ICT				<p>Clause 7.1.9 (Page 35) In addition, the Concessionaire shall install, operate and maintain an automated Gate Management System to ensure transparent and accurate reporting of total cargo throughput at the entry and exit gate of the terminal. The Concessionaire shall ensure live access of Gate Management System to the Concessions Authority. The system shall report the entry time, exit time, type of cargo and quantity of cargo carried by the vehicle exiting the terminal</p>	<ul style="list-style-type: none"> · The capital cost for installing the automated gate management system including software cost is very high. · This cost is not considered in the capital cost of the project which is required to be included in the capital cost of the project. · What happens to the gate management system after the expiry of the Concession period. 	<p>Capital cost for installing gate management system is not included in Total Project Cost because the system does not contribute to the terminal capacity of 3.07 mmtpa</p> <p>As per Article 18.2.4 of Draft Concession Agreement, it shall be an obligation of the Concessionaire to "transfer technology and up-to-date know-how relating to operation and maintenance of the Terminal's Assets and/or the Project Facilities and Services" to the Concessions Authority at the end of concession period</p>

S No	Bidder name	S No as per bidder	Page no	Article no	Text provided in document	Queries with justification (if any)	IWAI response to bidders
203	ICT				Clause 7.1.2 Marine and Terminal Services (b) Concessionaire share provide pilotage and towage services at the waterfront on the Project Site	· It is requested that pilotage and towage services should be under the obligation of the Concessioning Authority.	No change, bid conditions prevail
204	ICT				Clause 9.2.1 (Page 42) All such payments shall be exclusive of applicable taxes which the Concessionaire will pay over and above Royalty payments.	· Please indicate the taxes and rate applicable on Royalty Payments	Bidders may self-evaluate taxes applicable
205	ICT				Annexure IV (Page 102/450) Performance Standard at Sl. No.3 & 4	· We understand that that the Key Performance Indicators 3 & 4 relate only to ship-to-shore handling. Kindly confirm our understanding	These KPIs pertain to water-side productivity

S No	Bidder name	S No as per bidder	Page no	Article no	Text provided in document	Queries with justification (if any)	IWAI response to bidders
206	ICT				Annexure IV (Page 159) Performance Standard at Sl. No.5 – Average turnaround time of trucks	<ul style="list-style-type: none"> · The Average turnaround time of 120 minutes may be specified only in respect of container trucks moving within the terminal. For trucks carrying bulk, break-bulk and bagged cargoes, the average turnaround time will have to be much higher. · This performance standard may be related only to trucks moving riverine cargo. 	Please refer amendment 11.
208	ICT					<ul style="list-style-type: none"> · Kindly confirm that users of the proposed “Multimodal Terminal” will not have to pay any wharfage to Kolkata Port Trust. 	Response to this query shall be shared in second set of responses to pre-bid queries.

S No	Bidder name	S No as per bidder	Page no	Article no	Text provided in document	Queries with justification (if any)	IWAI response to bidders
209	ICT				Table 16.6 O&M Cost Estimates (Page 375/450) For calculating O&M cost estimates, the unit cost is taken as Rs. 6.50	<ul style="list-style-type: none"> · Electricity tariff for commercial usage outside port by WESEB is Rs. 7.90 per unit & in case the power is taken from Kolkata Port the tariff is ~ Rs. 13 per unit. · Kindly clarify which electricity rates will be applicable to concessionaire. 	Standard tariff rates of respective utility provider shall be applicable
210	ICT				-	The rates are subject to revision every year depending upon 60% of the WPI variation. It is not clear that it will be interpreted to mean that if there is a decline in WPI, rates will be reduced as per the clause. It is, therefore, requested to make it as "WPI increase", instead of variation, as in the case of TAMP rates.	No change, bid conditions prevail

Queries regarding DPR

S No	Bidder name	S No as per bidder	Page no	Article no	Text provided in document	Queries with justification (if any)	IWAI response to bidders
1	IRC	37 38	282 300	6.1 of DPR 7.1.1 of DPR (Ref Art. 7.3 of DPR)	<p>Traffic Forecast : As the IWT sector is in a nascent stage, the diversion of traffic to IWT would depend on the government policies and several other factors.</p> <p>Alternative Terminal Layouts : Alternative I</p>	<p>In 2020 dry bulk fly ash quantity indicated as 1381163 Tons. Fly ash loading in all the three jetties at Haldia and the proposed jetty at Kolaghat must be stopped. Even then, the figure given in the Table is considerably higher than the current quantity of fly ash available at Haldia.</p> <p>Alternative I has been recommended and selected as a preferred alternative for MMT Haldia as per Article 7.3 : Recommended Terminal Layout which considers 2.71 MTPA (88%) of fly ash out of a total cargo of 3.08 MTPA.</p> <p>We suggest issues related to cargo availability, minimum guarantee of cargo etc. be decided after operation of the terminal</p>	Bidders are requested to carry out their own due diligence.

S No	Bidder name	S No as per bidder	Page no	Article no	Text provided in document	Queries with justification (if any)	IWAI response to bidders
						for 10 years with a 30 years concession period on mutual discussion based on situation prevailing at that point of time.	
2	IRC	39	359	14.1.2 of DPR	External Connectivity : Proposed Rail Connectivity : Rail connectivity from the existing main railway line is proposed for future rail borne traffic as shown in Drawing I-525/HT/210.	This is considered vital for cargo development. Kindly confirm whether the proposed rail connectivity could be completed within 1 year.	Railway layout plan completed by M/s RITES in consultation with Southern Railway Railway connectivity development shall be completed with 24 months of awarding EPC contract for the same

S No	Bidder name	S No as per bidder	Page no	Article no	Text provided in document	Queries with justification (if any)	IWAI response to bidders
3	IRC	40	360	14.2.2.1 of DPR	<p>Proposed road connectivity : Approach Road :</p> <p>The truck traffic movement for Haldia MMT is expected to be initially 600 trucks / day which is expected to increase to 800 trucks / day. This will lead to queuing in the approach road of the terminal and hence the existing two lane road will not be sufficient to handle such truck movement. Therefore, the existing two lane road will be widened to four lane road along with the development of an additional bridge to cater the terminal traffic.</p> <p>The widening of approach road providing access to the terminal is</p>	<p>The proposed approach road is vital for cargo development. Kindly confirm earliest date by which the proposed widening of approach road providing access to the terminal would be completed.</p>	<p>IWAI shall provide two lane connecting road</p>

S No	Bidder name	S No as per bidder	Page no	Article no	Text provided in document	Queries with justification (if any)	IWAI response to bidders
					planned considering the site flexibility		
4	IRC	41	367	16.2 of DPR Item 8.3	Conveyor system with fixed hopper & foundation	It appears a belt conveyor is being provided for conveying fly ash from silo to berths. We suggest a pneumatic conveying system for this purpose. Kindly clarify.	Belt Conveyor system is available from Berth to silos.

S No	Bidder name	S No as per bidder	Page no	Article no	Text provided in document	Queries with justification (if any)	IWAI response to bidders
5	HIPL	114	262	Annexure XVI, Exec Summary, Sec 2	The traffic potential of Haldia MMT as provided by M/s Hamburg Port Consulting GmbH, the traffic consultant is presented below.	<p>Please share all reports on studies and investigation pertaining to the Project that has been carried out by the authority including but not limited to Market Study, Bathymetry , Soil Investigation etc</p> <p>As built drawings, Mooring Analysis Report, Hydraulic Study, details of the fire-fighting equipment / facilities, to be also shared by IWAI, as these would be essential for the bidder to evaluate the project.</p> <p>Further, request to share details of source of water and intake system for the fire-fighting system, local navigation chart, illumination design drawings.</p>	Please refer Annexures 2, 15 and 16 (to this document)

S No	Bidder name	S No as per bidder	Page no	Article no	Text provided in document	Queries with justification (if any)	IWAI response to bidders
6	HIPL	115	263	Annexure XVI, Exec Summary, Sec 3	However, for flyash the design vessel has been considered as 1500 DWT, since these vessels will be primarily used for flyash export to Bangladesh via Sundarbans.	Please provide the LAD in the waterway channel travelling to Bangladesh thru the Sundarbans.	LAD data is available on IWAI Portal (LADIS)
7	HIPL	116	263	Annexure XVI, Exec Summary Sec 4.1	Fly ash shall be coming to the terminal through bulkers and loaded to the silos pneumatically by pumps. Then it will be loaded to barges by barge loaders through pipe conveyor system. The handling of fly ash shall be carried out using bulkers discharging fly ash either into the silos or directly into the barges.	Please provide the as-built silo configuration and pipe conveyor system that would be handed over to the Concessionaire as part of Terminal's Assets . Please advise on the capacity of the existing silos and the pipe conveyor system and confirm it is sufficient to handle the 2.71 mmtpa of fly ash at berths 1&2.	Capacity of Silos: 1200 MT X 8 nos. Space available for future addition of silos. No pipe conveyor system only belt conveyor system is there.

S No	Bidder name	S No as per bidder	Page no	Article no	Text provided in document	Queries with justification (if any)	IWAI response to bidders
8	HIPL	117	264	Annexure XVI, Exec Summary Sec 5	Layout of Haldia MMT	<p>Please share detailed AUTO CAD version of the layout indicating the boundary co-ordinates and location of berths, silos, piping & conveyor system, buildings, roads and other back up yard infrastructure components that would be handed over as Terminal's Assets to the Concessionaire</p> <p>Please confirm if there is any waterbody within the Project Site</p>	Please refer Annexure 2 (to this document)
9	HIPL	118	264	Annexure XVI, Exec Summary Sec 5 and Sec 6.2.1.2	It is considered that to maintain the turning/berthing/holding area at about 3.2m below CD, the further annual maintenance dredging will be about 0.5Mm ³ /year. Similarly the further annual maintenance dredging requirement for the access channel is	Please confirm that the Concessioning Authority would ensure LAD for design vessel draft of 2.5 m at berth pocket, turning circle and channel all throughout the year and carry out required capital and annual maintenance dredging.	Concessioning Authority shall endeavour to maintain LAD at channel, berth pockets, adequate turning circle as per Article 7.3.3 of DCA

S No	Bidder name	S No as per bidder	Page no	Article no	Text provided in document	Queries with justification (if any)	IWAI response to bidders
					assessed to be about 1.8Mm ³ /year.		
10	HIPL	119	266	Annexure XVI, Exec Summary Sec 7.1	The existing ground level varies from +4.95 m CD to +8.21 m CD. It is proposed to provide the formation level of +7.80m CD within the terminal area.	Please confirm that the site formation level of +7.8 m CD would be carried out by Concessioning Authority before handover of Terminal's Assets.	Yes, Site formation level is +7.8 m CD.

S No	Bidder name	S No as per bidder	Page no	Article no	Text provided in document	Queries with justification (if any)	IWAI response to bidders
11	HIPL	120	267	Annexure XVI, Exec Summary Sec 7.6	<p>The existing approach road to the terminal will be retained. However, the existing riverside road leading to Tata chemicals factory will fall under the terminal area. It will have to be closed for terminal operation. Therefore, it is proposed to develop a 15 m wide diversion road for the same, on the western side of the terminal.</p>	<p>Please share details of the existing approach road indicating its extent and layout w.r.t the Project site boundary.</p> <p>Please clarify how would the berth trestle be linked to the Terminal across this existing riverside road along with status of necessary clearances to be obtained</p> <p>Please provide the timelines when the road to Tata Chemicals would be closed and can be made available to the Concessionaire for approach to berth area</p> <p>Please share the layout of the diversion road planned on the western side of the Terminal</p>	<p>Approach Road is shown in Drawing No. HT 206 of DPR.</p> <p>Existing riverside road between terminal and Berth has been closed and approaches including steel bridges (4 nos.) have been constructed to connect with the terminal.</p> <p>Road to TATA Chemicals has already been diverted. New Road is under construction and nearing completion.</p> <p>Layout of the diversion road is shown in the Drawing No. HT 206 of DPR.</p>

S No	Bidder name	S No as per bidder	Page no	Article no	Text provided in document	Queries with justification (if any)	IWAI response to bidders
12	HIPL	121	271	Annexure XVI, Sec 2.2	<p>The multi-cargo Inland Water Transport (IWT) terminal is proposed in an area of 61 acres adjacent to Haldia Dock. The land belongs to Kolkata Port Trust and has already been handed over to IWAI on a long term lease basis.</p>	<p>Please provide the date of expiry of the Lease period.</p> <p>Please confirm that the entire area of 61 acres of the Project Site is on leased land which is contiguous and without any obstruction/ encroachments / pending litigations.</p> <p>Please confirm the Lease rentals for the project land of 61 acres would be borne by Authority throughout the Conession Period.</p>	<p>Lease period is for 30 years w.e.f. 02.11.2015</p> <p>Entire area of 61 Acres is on lease.</p> <p>Lease rentals shall be paid by IWAI</p>

S No	Bidder name	S No as per bidder	Page no	Article no	Text provided in document	Queries with justification (if any)	IWAI response to bidders
13	HIPL	122	277	Annexure XVI, Sec 2.7	Two ammonia pipelines of M/s Tata Chemical, being maintained by M/s Sanjana Cryogenic, pass through the proposed terminal site. It is proposed to relocate these pipelines into a 40 m wide pipeline corridor adjacent to the river bank. The pipeline will be laid above ground in the pipeline corridor.	<p>Please provide the estimated timeline of relocation of these pipelines and the entity that would be responsible to implement this project.</p> <p>Please clarify whether there would be any operational challenges at the Project Site and Project Facilities and Services due to the presence of these two pipelines.</p> <p>Please clarify if there is any clearance to be obtained before commercial operation of the Terminal in which case obtaining the same should be a Condition Precedent for the Concessioining Authority.</p>	<p>Pipeline has already been relocated.</p> <p>Indicative list of applicable permits and clearances to be sought have been included in Annexure XIII of DCA</p>

S No	Bidder name	S No as per bidder	Page no	Article no	Text provided in document	Queries with justification (if any)	IWAI response to bidders
14	HIPL	123	281	Annexure XVI, Sec 5.1	Design Vessel Size : It is assured that LAD of 3.0 m shall be maintained by IWAI for movement of vessels in Haldia-Farakka stretch	It is mentioned in section 6.2.1.2 of Detailed Project Report that the maximum draft available is 1.5 m within 200 m of the river bank which contradicts the minimum LAD of 3.0 m available as per Sec 5.1 of Detailed Project Report and Clause 7.3.3 . of the Concession Agreement. Please clarify and confirm that LAD would be made available to the Concessionaire for design vessel of 2.5 m in Haldia-Farakka stretch	LAD of 3.0 m between Haldia-Farakka stretch is envisaged under JMVP.
15	HIPL	124	290	Annexure XVI, Sec 6.2.4.3	Based on the above cargo handling arrangements for various commodities, the cargo handling rates assumed are presented in table below:	Please provide the basis of the calculation for the Cargo Handling rates. Does this consider all the Material Handling System/Equipment as defined in Section 8.2.5 of the Detailed Project Report.	Cargo handling rates have been considered keeping in view all equipment mentioned in Table 8.2. But IWAI is not procuring 2 MHC and 10 Dumper trucks.

S No	Bidder name	S No as per bidder	Page no	Article no	Text provided in document	Queries with justification (if any)	IWAI response to bidders
16	HIPL	125	291	Annexure XVI,, Sec 6.2.4.5	The productive cargo handling hours on an average in a day when the vessels are at berth has been taken as 20 hours to account for shift changes, equipment position changes and for any unplanned stoppages.	Please note that he terminal being on inland waterway , typically operations can be caried out only during one shift or maximum 2 shifts owing to challenges in night navigation in the channel	We do not envisage any challenge in Night Navigation or Operation of the Terminal.
17	HIPL	126	298	Annexure XVI, 6.3.2.6 & 9.7	As the mode of transport of the commodities to / from the terminal is by road, a welldeveloped internal and external road network is required. Adequate area is provided for internal road network running throughout the whole terminal.	Please provide the layout of network of internal roads to be provided by the Concessioning Authority as part of Terminal's Assets. Please confirm that the Concessionaire is not required to build any additional internal roads for achieving the capacity of 3.07 mmtpa	Layout of Internal Road is available in Drawing No. HT 204.
18	HIPL	127	299	Annexure XVI, 6.3.2.8	A 10 m wide green belt is proposed along the boundary of the proposed IWT terminal	Please confirm that Green Belt as per requirement of the Environment Management Plan would be developed by Concessioning Authority	Yes.

S No	Bidder name	S No as per bidder	Page no	Article no	Text provided in document	Queries with justification (if any)	IWAI response to bidders
						before handover of Terminal's Assets	
19	HIPL	128	299	Annexure XVI, 6.3.2.9	A network of covered storm water drain with setting pond will be provided. Run off from the storage areas will be routed through collection pits.	Please provide the as-built layout of the Storm Water Drainage that would be provided by Concessioneing Authority as part of the Terminal's Assets	Storm Water Drainage layout to be provided to successful bidder
20	HIPL	129	306	Annexure XVI, Sec 8.3	The layout plan is enclosed as Drawing I-525/HT/209.	Please share the AutoCAD file of the layout plan	Please refer Annexures (to this document)
21	HIPL	130	359	Annexure XVI, Sec 14.2.1	During the site visit and as per topography survey, it is observed that there is an existing approach road which is well connected from the round circle junction to the proposed Haldia terminal. The existing road is a two lane road for a stretch of 800m having a width of 7m.	Please provide the end point co-ordinates of the extent of the 800 m existing approach road, its width, any existing railway crossings and where does it connect to the nearest highway.	There is 830 m approach road from entry gate of terminal to nearestt main road which connects to NH 41 at 5.3 KM distance.

S No	Bidder name	S No as per bidder	Page no	Article no	Text provided in document	Queries with justification (if any)	IWAI response to bidders
22	HIPL	131	360	Annexure XVI, Sec 14.2.2	Therefore, the existing two lane road will be widened to four lane road along with the development of an additional bridge to cater the terminal traffic	<p>Please clarify the estimated timeline for 4 laning expansion of the existing road that connects the site to NH 41.</p> <p>Also confirm that this additional 4 lane road would be constructed by the Concessioning Authority within the proposed timeline and would be its obligation under the Concession Agreement</p>	IWAI shall provide two lane connecting road
23	HIPL	A1	305, 400	Annexure XVI, Sec 8.2.1 & Dwg I-525 HT-204	Storage Areas	<p>Authority to confirm that the demarcated storage areas as shown in Dwg I-525 HT-204 including the area for storage of oil drums, fly ash silos, fertiliser shed, storage of aggregates and Future Storage area would be completely constructed and handed over to Concessionaire as part of Terminal's Assets prior to COD. Further, Authority to</p>	<p>Covered Shed for fertilizer, fly ash silos, storage areas for oil drums and storage of aggregates have been constructed by IWAI.</p> <p>Future storage area is for future construction. Not in the scope of present DPR.</p>

S No	Bidder name	S No as per bidder	Page no	Article no	Text provided in document	Queries with justification (if any)	IWAI response to bidders
						provide the build specification of these storage areas.	

S No	Bidder name	S No as per bidder	Page no	Article no	Text provided in document	Queries with justification (if any)	IWAI response to bidders
24	OSL	6	DPR Page-31	6.1	Traffic Forcast	<p>Has the traffic forcast taken into consideration the existing as well as futuristic competing facilities in and around the proposed Terminal. Will IWAI prevail upon operators of such competing facilities in order to ensure exclusivity, be it Government , Non-Government for diversion of those traffic being currently handled at present and likely to be handled in future.</p> <p>If IWAI / KOPT builds an second terminal/ Jetty within 75 - 100 kms radius, the viability of this terminal may be compromised for us, please advice. Will the cargo guarantee volume be lowered for the cargo which shifts ? or how will it be dealt ?</p> <p>Would we be allowed to Discharge Lighterage Cargo from barges orginating</p>	<p>Bidders are requested to carry out their own due diligence.</p> <p>No change, bid conditions prevail</p>

S No	Bidder name	S No as per bidder	Page no	Article no	Text provided in document	Queries with justification (if any)	IWAI response to bidders
						from Sandheads / Sagour / Diamond Harbour / Coastal	

Environmental observations

S No	Bidder name	Text provided in document	Queries with justification (if any)	IWAI response
1	Adani Logistics	Obligations of the Concessionaire Obtain Applicable Permits, comply with Applicable Laws and Applicable Permits and give priority to safety in its development/equipment and planning activities in order to protect life, health, property and environment;	What all Environment permissions has been obtained till date Need Copies of the Environment Permission & Compliance status for following 1. Environment & CRZ Clearance 2. Latest Compliance report of CRZ Clearance obtained for the project vide MoEF&CC letter dated 06.11.2017 3. WBCZMA Recommendation letter (for CRZ) dated 24.01.2017 & compliance of the recommendations 4. CER (Corporate Environment Responsibility) obligation & status 5. Forest & Wild Life Clearance (If applicable) 6. Consent to Establish & Consent to Operate from State Pollution Control Board under Air Act & Water Act 7. Hazardous Waste Authorization 8. Bio-medical Waste Authorization (if applicable) 9. A copy of Latest Compliance report of all the Environment Permission obtained (EC & CRZ, Forest, Wildlife. CTE, CTO, Environment Statement [Form V), Hazardous Waste Return (Form IV), E-Waste Return [Form 3] etc) 10. EIA & CRZ Status Report	Available copy of clearances: 1. CRZ Clearance & WBCZMA 2. Latest compliance report of CRZ Clearance & WBCZMA (jan-june 2019). 3. CER status included in CRZ compliance report 4. Consent to Establish & Consent to Operate for the batching plant in accordance with the provisions of the Water (Prevention and Control of Pollution) Act, 1974; 5. Consent to Establish & Consent to operate for the batching plant in accordance with the provisions of the Air (Prevention and Control of Pollution) Act, 1981; 6. Hazardous waste Authorization applied in SPCB 7. Copy of latest compliance reports are available. Copies shall be shared with successful bidder.

S No	Bidder name	Text provided in document	Queries with justification (if any)	IWAI response
			11. Any other obligation from Environment perspective and its compliance status	

S No	Bidder name	Text provided in document	Queries with justification (if any)	IWAI response
2	Adani Logistics	<p>Obligations of the Concessionaire (Berth & Terminal Operation)</p> <p>Obtain, maintain and comply with Applicable Permits and comply with the Applicable Laws including those relating but not limited to Terminal side safety, health, environment and labour;</p>	<p>Comments as above point 6.4.4</p>	<p>Available copy of clearances:</p> <ol style="list-style-type: none"> 1. CRZ Clearance & WBCZMA 2. Latest compliance report of CRZ Clearance & WBCZMA (jan-june 2019). 3. CER status included in CRZ compliance report 4. Consent to Establish & Consent to Operate for the batching plant in accordance with the provisions of the Water (Prevention and Control of Pollution) Act, 1974; 5. Consent to Establish & Consent to operate for the batching plant in accordance with the provisions of the Air (Prevention and Control of Pollution) Act, 1981; 6. Hazardous waste Authorization applied in SPCB 7. Copy of latest compliance reports are available. <p>Copies shall be shared with successful bidder.</p>
3	Adani Logistics	<p>Compliance with the Environment Management Plan</p> <p>The Concessionaire shall fully comply with the Environment Management Plan ("EMP") provided by the Concessioning Authority</p>	<p>EMP Compliance for Construction stage shall be removed including Environment Monitoring requirement for construction stage from the EMP requirement as provide in Annexure XV</p> <p>Kindly submit a compliance status of Construction stage EMP in order to</p>	<p>Compliance reports shall be shared with successful bidder</p>

S No	Bidder name	Text provided in document	Queries with justification (if any)	IWAI response
		during all times. Detailed provisions of the EMP are given in Annexure XV of this document.	understand Compliance Status and future obligation	
4	Adani Logistics	<p>Operation and maintenance of Waste Reception & Treatment Facility</p> <p>The Concessionaire shall take over operation and maintenance of the Waste Reception & Treatment Facility infrastructure at the Terminal from the Concessioning Authority on COD to provide waste reception services to vessels as per Schedule IV of Ministry of Shipping Notification dated 13 July 2016.</p>	<p>No detail of Waste Reception & Treatment Facility</p> <p>Need to understand what Waste Reception & Treatment Facility has been developed at site and its technical details (Capacity, Coverage of waste, permission for the same etc).</p> <p>Has this been reflected in Consents obtained from State Pollution Control Board?</p> <p>A copy of Schedule IV of Ministry of Shipping Notification dated 13 July 2016 and the is also needed</p>	Please refer S. No. 54 of Queries regarding DCA

S No	Bidder name	Text provided in document	Queries with justification (if any)	IWAI response
5	Adani Logistics	<p>Salient environmental features of Haldia Terminal</p> <p>1. Ecological environment</p> <p>Critically Polluted Area: Haldia was declared by CPCB a “Critically Polluted Area (CPA’s) by Advt. No. B-29012/ESS/CPA/2010. However, the moratorium has now been lifted vide MoEF Office Memorandum N. J - 11013/5/2010 -IA. II (i) dated 17.09.2013. The proposed project is identified as vital infrastructure requirement of the Haldia Dock complex for its economy, better serviceability to end customer and to improve the primary / secondary logistic cost.</p>	<p>We do understand that CPA moratorium has been lifted but is there any restriction on account of area being in CPA earlier or any compliance obligation on account of this and any restriction for activity from SPCB/CPCB?</p>	<p>No restriction due to CPA.</p>
6	Adani Logistics	<p>It will be essential for contractor to comply with applicable regulations and World Bank safeguard requirements</p>	<p>We do understand that contractor is expected to comply with EMP including Environment Monitoring & submit a quarterly compliance report and EMP has been framed in line to World Bank safeguard requirements. Just want a clarity on this point that there is no further obligation from Environment side apart from complying with EMP, applicable</p>	<p>Concessionaire shall perform all obligations as per DCA and EMP</p>

S No	Bidder name	Text provided in document	Queries with justification (if any)	IWAI response
			Environmental regulations & submitting the EMP compliance report on quarterly basis	
7	Adani Logistics	1.1 Impact Climate Ensuring survivability of trees planted under greenbelt minimum 70% survival rate and create additional GHG sink by planting additional trees	Has Green belt has already developed during construction stage? Need to understand how many plantation has been carried out so far including details of compensatory plantation. Permissions obtained. Species planted and survival rate as on date.	Greenbelt is being developed on site and 1800 no. of saplings have been planted including compensatory plantation. Survival rate is 90%.
8	Adani Logistics	1.1 Impact Climate Adopting all energy efficiency measures e.g the terminal building should have a platinum rated for Green building provisions	Whose responsibility? It should have been ensured during design and construction stage as per the document	Shall be provided by IWAI
9	Adani Logistics	1.1 Impact Climate Street lighting solar lighting provisions (on 1:3 ratio of minimal needs) along with solar power generation § Comments as above system should also be provided as to meet the other power requirements of the terminal	Comments as above	Shall be provided by IWAI

S No	Bidder name	Text provided in document	Queries with justification (if any)	IWA response
		thus reducing dependence on power grid supply.		
10	Adani Logistics	<p>2. Air Quality</p> <p>2.1 Air pollution due to due to vehicular movement& loading and unloading areas</p> <p>2.1.3. Thick green belt shall be developed as per the provision already made in design (3 acres' green belt area) and maintained all along the periphery and along the roads. The green belt shall be developed in canopy shape with local species of broad leaf variety. Species selected for development of green belt shall also be tolerant to expected pollutants and shall have the ability to adsorb the pollutants. Suggested species are suitable for different areas are also listed under CPCB guidelines for green</p>	<p>Has Green belt has already developed during construction stage?</p> <p>Need clarity on this part as we need to develop or maintain the developed greenbelt. Clause needs to be modified accordingly.</p>	<p>Greenbelt is being developed on site and 1800 no. of saplings have been planted including compensatory plantation. Survival rate is 90%.</p>

S No	Bidder name	Text provided in document	Queries with justification (if any)	IWA response
		<p>Belt development.</p> <p>2.1.9 Green belt planted should be maintained and survival rate of plantation should be maintained to minimum 70%</p>		
11	Adani Logistics	<p>2. Air Quality</p> <p>2.1 Air pollution due to due to vehicular movement& loading and unloading areas</p> <p>Upgrading the land vehicle fleet with lesspolluting trucks and vehicles, and using alternative fuels and fuel mixture</p>	What do we mean by use of alternate fuels & fuel mixture? For what purpose?	Bidders are encouraged to perform their own due diligence

S No	Bidder name	Text provided in document	Queries with justification (if any)	IWAI response
12	Adani Logistics	<p>Noise Quality</p> <p>2.1 Noise due to Operation</p> <p>2.1.2 Provision of thick green belt along the boundary and roads which will act as noise buffer</p> <p>2.1.4 Provision of thick green belt along the boundary and roads which will act as noise buffer (REPEAT)</p>	<p>Has Green belt has already developed during construction stage?</p> <p>Need clarity on this part as we need to develop or maintain the developed greenbelt. Clause needs to be modified accordingly</p>	<p>Greenbelt is being developed on site and 1800 no. of saplings have been planted including compensatory plantation. Survival rate is 90%.</p>
13	Adani Logistics	<p>Land and soil</p> <p>3.1 Soil erosion at embankment during heavy rainfall.</p> <p>3.1.1 Periodic checking to be carried to monitor the soil erosion along the River Banks at and near terminal area</p>	<p>Will it be visual check?</p>	<p>Periodic monitoring will be required through NABL accredited lab</p>
14	Adani Logistics	<p>3.2 Soil contamination</p> <p>3.2.1 Fuel shall be stored in HDPE containers on paved surfaces only to prevent spillage of fuels on the soil and thus soil contamination.</p> <p>3.2.2 Edible oil and POL shall be stored in HDPE drums on paved surface.</p>	<p>Storage area with paved surface available for storing of fuel & edible oil POL?</p>	<p>Storage area is available for used oil and there is no e-waste generated on site.</p>

S No	Bidder name	Text provided in document	Queries with justification (if any)	IWAI response
15	Adani Logistics	3.2 Soil contamination 3.2.5 Used oil from DG sets and other equipment shall be stored in HDPE containers in isolated location on paved surfaces and shall be disposed through authorized vendors only and shall not be dumped in open	Waste Storage yard/area developed with paved surface for storage of Used Oil other Hazardous Waste, Solid Waste?	Please refer Annexure 2
16	Adani Logistics	3.2 Soil contamination 3.2.6 Room shall be provided for storage of E-waste at site and this waste shall be sold to authorized vendors periodically and shall not be dumped in open.	Room for E-waste storage available?	Please refer Annexure 2
17	Adani Logistics	3.2 Soil contamination 3.2.7 Bio- medical waste likely to be generated at first aid centre shall be disposed of following the bio medical waste disposal rules	First Aid Centre/OHC available at site? BMW Authorization obtained?	First aid center is available at site. BMW Authorization is not required.
18	Adani Logistics	3.2 Soil contamination 3.2.8 Dredged soil shall be tested for toxicity prior disposal, if toxic it shall not be disposed off back in water and should be send for	Do we have obtained Membership with Haldia Dock TSDf facility? Or have any tie up with them?	Not applicable for Haldia MMT at this stage

S No	Bidder name	Text provided in document	Queries with justification (if any)	IWA response
		disposal to TSDF of Haldia Dock Complex		
19	Adani Logistics	<p>3.2 Soil contamination</p> <p>3.2.10 Vessel waste reception facility should be available at the terminal site incase maintenance facility is not in place. The waste should be received from the vessel in proper segregated and packed form. This waste should be treated and disposed within the terminal site only but in case it is not feasible, tie ups with Government and authorized private agencies can be made for handling, treatment, storage and disposal of this waste. Also fee can be imposed on the vessel operator for letting them dispose their waste at terminal/maintenance facilities.</p>	Vessel Waste reception facility available at site? Kindly provide details (Facilities available, area, and other relevant details of the same)	Please refer S. No. 54 of Queries regarding DCA

S No	Bidder name	Text provided in document	Queries with justification (if any)	IWA response
20	Adani Logistics	<p>4. Water resources/Flooding and Inundation</p> <p>4.2 Water logging due to blockage of drains, culverts or streams</p> <p>4.2.4 Storm water drains provided in parking & road areas shall be provided with oil & grease traps</p>	Storm water drains developed in parking & road areas?	Construction of Storm water drains is in progress
21	Adani Logistics	<p>4. Water resources/Flooding and Inundation</p> <p>4.3 Waste Water Treatment & Conservation</p> <p>4.3.1 Provision of storm water harvesting system at site. Surface storm water shall be collected in collection pond at the site and will be retained for 30 min. This water can be again used for dust suppression purpose within the site. Roof top rain water should be collected in separate collection pond and should be used for horticulture and cleaning purpose at site.</p>	Storm water harvesting system developed? Collection pond for roof top rain water collection available?	Collection pond is available for roof top rain water collection

S No	Bidder name	Text provided in document	Queries with justification (if any)	IWA response
22	Adani Logistics	<p>4. Water resources/Flooding and Inundation</p> <p>4.3 Waste Water Treatment & Conservation</p> <p>4.3.3 Toilets to be provided with running water facility to prevent open defecation.</p>	Toilets available?	Toilets are available on site
23	Adani Logistics	<p>4. Water resources/Flooding and Inundation</p> <p>4.3 Waste Water Treatment & Conservation</p> <p>4.3.4 Sewage generated at terminal site shall be treated in house. STP of 30 KLD shall be provided for treatment of sewage and treated water shall be reused in green belt development and dust suppression. No waste/wastewater shall be discharged in river or dumped into the ground</p>	STP available at Site?	30 KLD STP is being constructed on site

S No	Bidder name	Text provided in document	Queries with justification (if any)	IWA response
24	Adani Logistics	<p>4. Water resources/Flooding and Inundation</p> <p>4.3 Waste Water Treatment & Conservation</p> <p>4.3.5 Water conservation fixtures shall be installed in toilets and kitchen area. Some of the water conservation fixtures which can be installed are dual flushing cisterns, sensor taps, low water urinals etc.</p>	These fixtures have been installed?	Please refer Annexure 2
25	Adani Logistics	4.3.8 Dredged soil shall be tested for toxicity, if toxic shall not be disposed off back in water or river banks and should be send for disposal to approved TSDF of Haldia Dock Complex.	Do we have obtained Membership with Haldia Dock TSDF facility? Or have any tie up with them?	Not applicable for Haldia MMT at this stage
26	Adani Logistics	4.3.10 Oil should be stored in leak proof containers and storage area should be provided with facility of collecting the oil in case of spillage. The storage facility should be so designed that spilled oil shall not enter the storm water and sewage drains or storm water storage	<p>Storage area with paved surface available at site for storage of Oil?</p> <p>Oil & grit separators provided in storm water drain?</p>	Storage area is available for used oil

S No	Bidder name	Text provided in document	Queries with justification (if any)	IWA response
		pits. Oil storage facility should be contained. Oil & grit separators should be provided in the storm water drains in these areas		
27	Adani Logistics	<p>5. Flora and Fauna</p> <p>a. Terrestrial Flora & Fauna</p> <p>5.a.1 Thick green belt in area of 3 Acre will be developed at site by the time operation starts at the project site. This will improve the ecology of the area and will provide the habitat to avifauna.</p> <p>5.a.2 70% survival of the plantation shall be maintained. The tree survival audit to be conducted at least once in a year to assess the effectiveness</p>	<p>Thick green belt has been developed?</p> <p>Need to understand how many plantation has been carried out so far area coverage, number) including details of compensatory plantation. Permissions obtained. Species planted and survival rate as on date.</p>	<p>Greenbelt is being developed on site and 1800 no. of saplings have been planted including compensatory plantation. Survival rate is 90%.</p>

S No	Bidder name	Text provided in document	Queries with justification (if any)	IWA response
28	Adani Logistics	<p>5. Flora and Fauna b. Impact on Aquatic Flora & Fauna due to vessel movement & discharge of waste c. Impact Due to Oil spillage</p> <p>7. STP should be provided at site for treatment of sewage generated. No sewage should be allowed to enter in the river. Treated water from STP should be reused completely at site and should not be discharged into river</p> <p>13. Propeller guards should be provided for all the vessels to minimize the propeller inflicted injuries and scars to the aquatic organisms.</p>	STP available at site?	30 KLD STP is being constructed on site
29	Adani Logistics	<p>5. Flora and Fauna b. Impact on Aquatic Flora & Fauna due to vessel movement & discharge of waste c. Impact Due to Oil spillage</p> <p>15. Nesting grounds, breeding & spawning</p>	Kindly provide the details of all such nesting grounds, breeding & spawning ground	Please refer Annexure 18

S No	Bidder name	Text provided in document	Queries with justification (if any)	IWA response
		<p>grounds shall be identified and project activities shall be minimized in those areas</p>		
30	Adani Logistics	<p>6. Safety 6.4 Accidents Risks Due to Movement of Vessels and other hazards associated with site</p> <p>Employment should preferably be given to local people. Women should be given equal opportunity for work.</p> <p>Development activities should be carried out in the nearby areas for development of area</p> <p>Fishing activity should not be restricted in the river.</p> <p>Alternate provision for fishermen should be given in</p>	<p>These are related to Social, CSR and not Accidental Risk due to movement of vessels.</p>	<p>SIA has been conducted on site and no fishermen community is being impacted.</p>

S No	Bidder name	Text provided in document	Queries with justification (if any)	IWA response
		case fishing activity is restricted.		
31	Adani Logistics	<p>Environment monitoring operation phase Construction Stage Environment Monitoring requirement may be removed from EMP Need Monitoring details of Construction Stage (Parameters Monitored, Location, Frequency, Agency. Reports etc) Environment Monitoring Matrix for Operation stage says Surface Water Quality Monitoring frequency as quarterly however EMP</p>	<p>In EMP point also it should be made quarterly in line to Environment Monitoring Matrix.</p>	<p>Frequency of surface water monitoring in operation phase will be on every quarter.</p>

S No	Bidder name	Text provided in document	Queries with justification (if any)	IWAI response
		(Operation Stage) point 4.3 bullet 9 says Monitoring of surface water quality shall be carried out on monthly basis to check the level of pollutants and effectiveness of proposed EMP –		

Amendments

S No	Document	Article no.	As per bid document	To be read as
1	RFP	2.2.1.(a).(iv)	<p>Eligibility of Bidders : Technical Capacity :</p> <p>An experience providing seaport terminal (containers, dry bulk, liquid bulk or general cargo)/ CFS/ ICD/ inland waterway terminal (containers, dry bulk, liquid bulk or general cargo) services and should have handled at least 5,372,500 (Five million three hundred seventy-two thousand and five hundred only) MT of cargo ...</p>	<p>Eligibility of Bidders : Technical Capacity :</p> <p>An experience providing seaport terminal (containers, dry bulk, liquid bulk or general cargo)/ CFS/ ICD/ inland waterway terminal/riverine terminal (containers, dry bulk, liquid bulk or general cargo) services and should have handled at least 5,372,500 (Five million three hundred seventy-two thousand and five hundred only) MT of cargo ...</p>
2	RFP	2.2.2 (b)	<p>Certificates from its statutory auditors specifying the revenue of the Bidder in respect of the Eligible Projects specified in Article 2.2.1(a) (iii) above.</p>	<p>Certificates from its statutory auditors specifying the revenue of the Bidder in respect of the Eligible Projects specified in Article 2.2.1(a) (i) above.</p>

S No	Document	Article no.	As per bid document	To be read as
3	RFP	2.1.15	<p>A Bidder shall be liable for disqualification and forfeiture of Bid Security if any legal, financial or technical adviser of the Authority in relation to the Project is engaged by the Bidder, its Members or any Associate thereof, as the case may be, in any manner for matters related to or incidental to such Project during the Bidding Process or subsequent to the (i) issue of the LOA or (ii) execution of the Concession Agreement. In the event any such adviser is engaged by the Selected Bidder or Concessionaire, as the case may be, after issue of the LOA or execution of the Concession Agreement for matters related or incidental to the Project, then notwithstanding anything to the contrary contained herein or in the LOA or the Concession Agreement and without prejudice to any other right or remedy of the Authority, including the forfeiture and appropriation of the Bid Security or Performance Security, as the case may be, which the Authority may have thereunder or otherwise, the LOA or the Concession Agreement, as the case may be, shall be liable to be terminated without the Authority being liable in any manner whatsoever to the Selected Bidder or Concessionaire for the same. For the avoidance of doubt, this disqualification shall not apply where such adviser was engaged by the Bidder, its Member or Associate in the past but its assignment expired or was terminated prior to the Bid Due Date. Nor will this disqualification apply where such adviser is engaged after a period of 3 (three) years from the date of commercial operation of the Project.</p>	<p>A Bidder shall be liable for disqualification and forfeiture of Bid Security if any legal, financial or technical adviser of the Authority in relation to the Project is engaged by the Bidder, its Members or any Associate thereof, as the case may be, in any manner for matters related to or incidental to such Project during the Bidding Process or subsequent to the (i) issue of the LOA or (ii) execution of the Concession Agreement. In the event any such adviser is engaged by the Selected Bidder or Concessionaire, as the case may be, after issue of the LOA or execution of the Concession Agreement for matters related or incidental to the Project, then notwithstanding anything to the contrary contained herein or in the LOA or the Concession Agreement and without prejudice to any other right or remedy of the Authority, including the forfeiture and appropriation of the Bid Security or Performance Security, as the case may be, which the Authority may have thereunder or otherwise, the LOA or the Concession Agreement, as the case may be, shall be liable to be terminated without the Authority being liable in any manner whatsoever to the Selected Bidder or Concessionaire for the same. For the avoidance of doubt, this disqualification shall not apply where such adviser was engaged by the Bidder, its Member or Associate in the past but its assignment expired or was terminated prior to the Bid Due Date. Nor will this disqualification apply where such adviser is engaged after a period of 1 (one) year from the date of commercial operation of the Project.</p>

S No	Document	Article no.	As per bid document	To be read as
4	DCA	1.1	"Exclusivity Period" shall have the meaning ascribed to it in Article 12.2.2	-
5	DCA	3.1.1 (j)	-	A joint site inspection shall be carried out by both the Concessionaire and the Concessing Authority and observations and results agreed upon by both the parties
6	DCA	5.4	<p>The Independent Engineer and Independent Surveyor selected pursuant to the aforesaid process shall be appointed within 90 (Ninety) Days of the date of this Agreement.</p> <p>The Independent Engineer and Independent Surveyor shall discharge its duties and functions substantially in accordance with the terms of reference set forth in Annexure -V.</p> <p>The Independent Engineer and Independent Surveyor shall submit regular periodic reports (at least once every month) to the Concessing Authority in respect of its duties and functions set forth in Annexure -V.</p>	<p>The Independent Engineer and Independent Surveyor selected pursuant to the aforesaid process.</p> <p>Independent Engineer shall be appointed within 90 (Ninety) Days of the date of this Agreement.</p> <p>Independent Surveyor shall be empaneled within 90 (Ninety) Days of the date of this Agreement through an empanelment process mutually agreed between Concessing Authority and Concessionaire. Services of the empaneled Independent Surveyor shall be availed in an event of unsuccessful vessel passage due to insufficient LAD is reported to the Concessing Authority. Payments to Independent Surveyor shall be made as per pre-decided rates only for the period when services of Independent Surveyor were availed. The Independent Engineer and Independent Surveyor shall discharge its their duties and functions substantially in accordance with the terms of reference set forth in Annexure -V. The Independent Engineer and Independent Surveyor shall submit regular periodic reports (at least once every month) to the Concessing Authority in respect of its duties and functions set forth in Annexure -V.</p>

S No	Document	Article no.	As per bid document	To be read as
7	DCA	6.7.3	<p>Upon completion of Development/Equipment Works and the Independent Engineer determining all the Tests to be successful, it shall forthwith issue to the Concessionaire and the Concessioneing Authority a Completion Certificate substantially in the form set forth in Annexure XI;</p>	<p>Upon completion of Development/Equipment Works and the Independent Engineer determining all the Tests to be successful, it shall forthwith issue to the Concessionaire and the Concessioneing Authority a Completion Certificate substantially in the form set forth in Annexure XII;</p>
8	DCA	6.7.4	<p>The Independent Engineer may, at request of the Concessionaire, issue a provisional certificate of completion substantially in the form set forth in Annexure XI (“Provisional Certificate”) if the Tests are successful and the Project can be safely and reliably placed in commercial operation though certain works or things forming part thereof are outstanding and not yet complete. The Provisional Certificate shall have appended thereto a list of outstanding items signed jointly by the Independent Engineer and the Concessionaire (“Punch List”) to be completed by the Concessionaire within a stipulated time. All items in the Punch List shall be completed by the Concessionaire within 90 (ninety) Days of date of issue of the Provisional Certificate or such other extended period that the Concessioneing Authority may in its sole discretion determine, failing which the Provisional Certificate shall lose its validity and the Concessioneing Authority shall be entitled to terminate this Agreement;</p>	<p>The Independent Engineer may, at request of the Concessionaire, issue a provisional certificate of completion substantially in the form set forth in Annexure XII (“Provisional Certificate”) if the Tests are successful and the Project can be safely and reliably placed in commercial operation though certain works or things forming part thereof are outstanding and not yet complete. The Provisional Certificate shall have appended thereto a list of outstanding items signed jointly by the Independent Engineer and the Concessionaire (“Punch List”) to be completed by the Concessionaire within a stipulated time. All items in the Punch List shall be completed by the Concessionaire within 90 (ninety) Days of date of issue of the Provisional Certificate or such other extended period that the Concessioneing Authority may in its sole discretion determine, failing which the Provisional Certificate shall lose its validity and the Concessioneing Authority shall be entitled to terminate this Agreement;</p>

S No	Document	Article no.	As per bid document	To be read as																		
9	DCA	Annexure III Terminal Equipment Phase, para 4	<p>As per DPR shared in Annexure XVI with this Agreement, design capacity of Terminal can be increased to at least 3.07 mmtpa by introducing the following equipment:</p> <table data-bbox="531 467 993 570"> <thead> <tr> <th>S No</th> <th>Equipment</th> <th>Number</th> </tr> </thead> <tbody> <tr> <td>1</td> <td>Mobile harbor crane</td> <td>1</td> </tr> <tr> <td>2</td> <td>Dumper trucks</td> <td>10</td> </tr> </tbody> </table>	S No	Equipment	Number	1	Mobile harbor crane	1	2	Dumper trucks	10	<p>As per DPR shared in Annexure XVI with this Agreement, design capacity of Terminal can be increased to at least 3.07 mmtpa by introducing the following equipment:</p> <table data-bbox="1222 467 1684 570"> <thead> <tr> <th>S No</th> <th>Equipment</th> <th>Number</th> </tr> </thead> <tbody> <tr> <td>1</td> <td>Mobile harbor crane</td> <td>2</td> </tr> <tr> <td>2</td> <td>Dumper trucks</td> <td>10</td> </tr> </tbody> </table>	S No	Equipment	Number	1	Mobile harbor crane	2	2	Dumper trucks	10
S No	Equipment	Number																				
1	Mobile harbor crane	1																				
2	Dumper trucks	10																				
S No	Equipment	Number																				
1	Mobile harbor crane	2																				
2	Dumper trucks	10																				

S No	Document	Article no.	As per bid document	To be read as
10	DCA	Annexure VI, Article 4.1	<p>At the beginning of every month, or at such shorter intervals as the Senior Lenders' Representative and the Concessionaire may by written instructions determine, the Escrow Bank shall withdraw amounts from the Escrow Account and appropriate them in the following order by depositing such amounts in the relevant Sub-Accounts for making due payments in a month:</p> <ul style="list-style-type: none"> (a) all taxes due and payable by the Concessionaire; (b) towards License Fee; (c) towards Royalty and other sums payable to the Concessioning Authority and liquidated damages, if any; (d) towards its debt service obligations under the Financing Documents; (e) all development/implementation expenses relating to the Project/Project Facilities and Services, in accordance with the Budget and subject to limits if any set out under the Financing Documents; (f) all expenses relating to operations and management of the Project/Project Facilities and Services, in accordance with the Budget and subject to limits if any set out under the Financing Documents; (g) towards any reserve requirements in accordance with the Financing Documents; <p>and the Concessionaire shall be at liberty to withdraw any sums outstanding in the escrow account after all the aforesaid payments due in any</p>	<p>At the beginning of every month, or at such shorter intervals as the Senior Lenders' Representative and the Concessionaire may by written instructions determine, the Escrow Bank shall withdraw amounts from the Escrow Account and appropriate them in the following order by depositing such amounts in the relevant Sub-Accounts for making due payments in a month:</p> <ul style="list-style-type: none"> (a) for all taxes due and payable by the Concessionaire; (b) towards payment of license fees; (c) all development/equipment expenses relating to Project Facilities and Services, subject to limits if any set out under Financing Documents; (d) all expenses relating to operation and maintenance of Project Facilities and Services, subject to limits if any set out under Financing Documents; (e) towards Concessionaire's debt service obligations under Financing documents; (f) towards payment of Royalty and other sums payable to the Concessioning Authority and liquidated damages, if any; (g) towards any reserve requirements in accordance with Financing Documents; and <p>and the Concessionaire shall be at liberty to withdraw any sums outstanding in the escrow account after all the aforesaid payments due in any Quarter have been made and/or adequate reserves have been created in respect thereof for that Quarter.</p>

S No	Document	Article no.	As per bid document	To be read as
			Quarter have been made and/or adequate reserves have been created in respect thereof for that Quarter.	

S No	Document	Article no.	As per bid document	To be read as
11	DCA	Annexure IV, 6	<ul style="list-style-type: none"> • Frequency: Quarterly • Actual average turnaround of trucks = $\Sigma(\text{Gate out time} - \text{Gate in time}) / \text{total number of trucks}$ Wherein: Gate-in time means time at which the driver enters terminal gate Gate-out time means time of reception of documentation which would allow the truck to exit the terminal	<ul style="list-style-type: none"> • Frequency: Quarterly • Actual average turnaround of trucks = $\Sigma(\text{Gate out time} - \text{Gate in time or Parking out time whichever is later}) / \text{total number of trucks}$ Wherein: Gate-in time means time at which the driver enters terminal gate Gate-out time means time of reception of documentation which would allow the truck to exit the terminal
12	DCA	Annexure IV, 2	<ul style="list-style-type: none"> • Frequency: Quarterly • Actual equipment availability = $(1 - ((\text{Planned maintenance hours} + \text{downtime hours}) / \text{total deployed hours})) \times 100$ Wherein: Planned maintenance hours is the actual number of preventive maintenance hours during which the equipment was not running Downtime hours is the actual number of hours during which the equipment was not running due to failure of the equipment Total deployed hours is the total number of hours for which an equipment is given to the operations team	<ul style="list-style-type: none"> • Frequency: Quarterly • Actual equipment availability = $(1 - ((\text{Planned maintenance hours} + \text{downtime hours}) / \text{total calendar hours})) \times 100$ Wherein: Planned maintenance hours is the actual number of preventive maintenance hours during which the equipment was not running Downtime hours is the actual number of hours during which the equipment was not running due to failure of the equipment

S No	Document	Article no.	As per bid document	To be read as
13	DCA	Annexure XI	This Guarantee shall be unconditional and irrevocable and shall remain in full force and effect until Scheduled Project Completion Date and for a period of twelve months thereafter unless discharged/released earlier by the Board in accordance with the provisions of the Concession Agreement.	The Performance Guarantee shall be for a sum of INR 4.8 crore (INR Four crore and eighty lakh only) effective from COD till the end of the Concession Period.
14	RFP	Annexure III : Note	For conversion of US Dollars to INR, the rate of conversion shall be daily exchange rates published by the Reserve Bank of India for the Bid Due Date. In case of any other currency, the same shall first be converted to US Dollars, and the amount so derived in US Dollars shall be converted into INR at the aforesaid rate. The conversion rate of such currencies to US Dollars shall be the daily representative exchange rates published by the International Monetary Fund for the relevant date.	For conversion of US Dollars to Rupees, the rate of conversion shall be INR [75 (INR Seventy five)] to a US Dollar. In case of any other currency, the same shall first be converted to US Dollars as on the date 60 (sixty) days prior to the Application Due Date, and the amount so derived in US Dollars shall be converted into Rupees at the aforesaid rate. The conversion rate of such currencies shall be the daily representative exchange rates published by the International Monetary Fund for the relevant date

S No	Document	Article no.	As per bid document	To be read as
15	DCA	Article 9.4.1	<p>9.4.1. Withdrawals and appropriations during the Concession Period, at any relevant time, from the Escrow Account shall be in the following order of priority:</p> <ul style="list-style-type: none"> (a) for all taxes due and payable by the Concessionaire; (b) towards payment of license fees; (c) all development/equipment expenses relating to Project Facilities and Services, subject to limits if any set out under Financing Documents; (d) all expenses relating to operation and maintenance of Project Facilities and Services, subject to limits if any set out under Financing Documents; (e) towards payment of Royalty and other sums payable to the Concessioneing Authority and liquidated damages, if any; (f) towards Concessionaire’s debt service obligations under Financing documents; (g) towards any reserve requirements in accordance with Financing Documents; and the Concessionaire shall be at liberty to withdraw any sums outstanding in Escrow Account after all the aforesaid payments due in any Quarter have been made and/or adequate reserves have been created in respect thereof for that Quarter. Provided, upon issuance of Termination Notice and/or suspension of the Concessionaire in accordance with provisions of this Agreement, withdrawal from the Escrow Account shall be made only in accordance with written instructions of the Concessioneing Authority and the Senior Lenders. 	<p>9.4.1. Withdrawals and appropriations during the Concession Period, at any relevant time, from the Escrow Account shall be in the following order of priority:</p> <ul style="list-style-type: none"> (a) for all taxes due and payable by the Concessionaire; (b) towards payment of license fees; (c) all development/equipment expenses relating to Project Facilities and Services, subject to limits if any set out under Financing Documents; (d) all expenses relating to operation and maintenance of Project Facilities and Services, subject to limits if any set out under Financing Documents; (e) towards Concessionaire’s debt service obligations under Financing documents; (f) towards payment of Royalty and other sums payable to the Concessioneing Authority and liquidated damages, if any; (g) towards any reserve requirements in accordance with Financing Documents; and the Concessionaire shall be at liberty to withdraw any sums outstanding in Escrow Account after all the aforesaid payments due in any Quarter have been made and/or adequate reserves have been created in respect thereof for that Quarter. Provided, upon issuance of Termination Notice and/or suspension of the Concessionaire in accordance with provisions of this Agreement, withdrawal from the Escrow Account shall be made only in accordance with written instructions of the Concessioneing Authority and the Senior Lenders.

S No	Document	Article no.	As per bid document			To be read as		
			S No	Event Description	Date	S No	Event Description	Date
16	RFP	1.3	4.	Bid due date	15 July 2020	4.	Bid due date	16 November 2020
			5.	Bid opening date	16 July 2020	5.	Bid opening date	17 November 2020
			6.	Letter of Award (LOA)	31 August 2020	6.	Letter of Award (LOA)	31 December 2020
			7.	Validity of Bids	120 (One hundred and twenty) days	7.	Validity of Bids	120 (One hundred and twenty) days
			8.	Signing of Concession Agreement (“Appointed Date”)	30 September 2020	8.	Signing of Concession Agreement (“Appointed Date”)	1 February 2021

List of Annexures*

S No	Annexure Number	Description
1	Annexure 1	Cost breakup
2	Annexure 2	As-built layout of terminal
3	Annexure 3	Land details
4	Annexure 4	Terminal Administrative Building
5	Annexure 5	Section 17 of the Inland Waterways Authority Act, 1985
6	Annexure 6	HPC traffic study report
7	Annexure 7	EC for Haldia MMT
8	Annexure 8	Conversion rate for 1 TEU
9	Annexure 9	Hydrography Chart between the proposed IWAI Terminal and the Haldia Port Lock Gate
10	Annexure 10	Drawing of the approach channel for Haldia MMT
11	Annexure 11	Historical hydrographic data
12	Annexure 12	Schedule IV of Ministry of Shipping Notification dated 13 July 2016
13	Annexure 13	Disaster management plan
14	Annexure 14	Crisis management plan
15	Annexure 15	Bathymetry study
16	Annexure 16	Soil investigation study
17	Annexure 17	List of advisors to IWAI
18	Annexure 18	Details of nesting grounds etc.

* Please refer all corrigenda sequentially for annexures

Annexures

Annexure 1: Breakup of total project cost

Item	Unit	Value
Mobile harbor crane (2 Nos)	INR crore	38.7
Dumper truck (10 Nos)	INR crore	3.5
Total equipment cost (base year)	INR crore	42.2
Base year	-	2016
Current year	-	2020
Cost escalation	%	3%
Total Project Cost (nominal terms)	INR crore	47.5

Annexure 2: Copy of as-built layout (in PDF) of Terminal

This page has been intentionally left blank. Please turn over to next page.

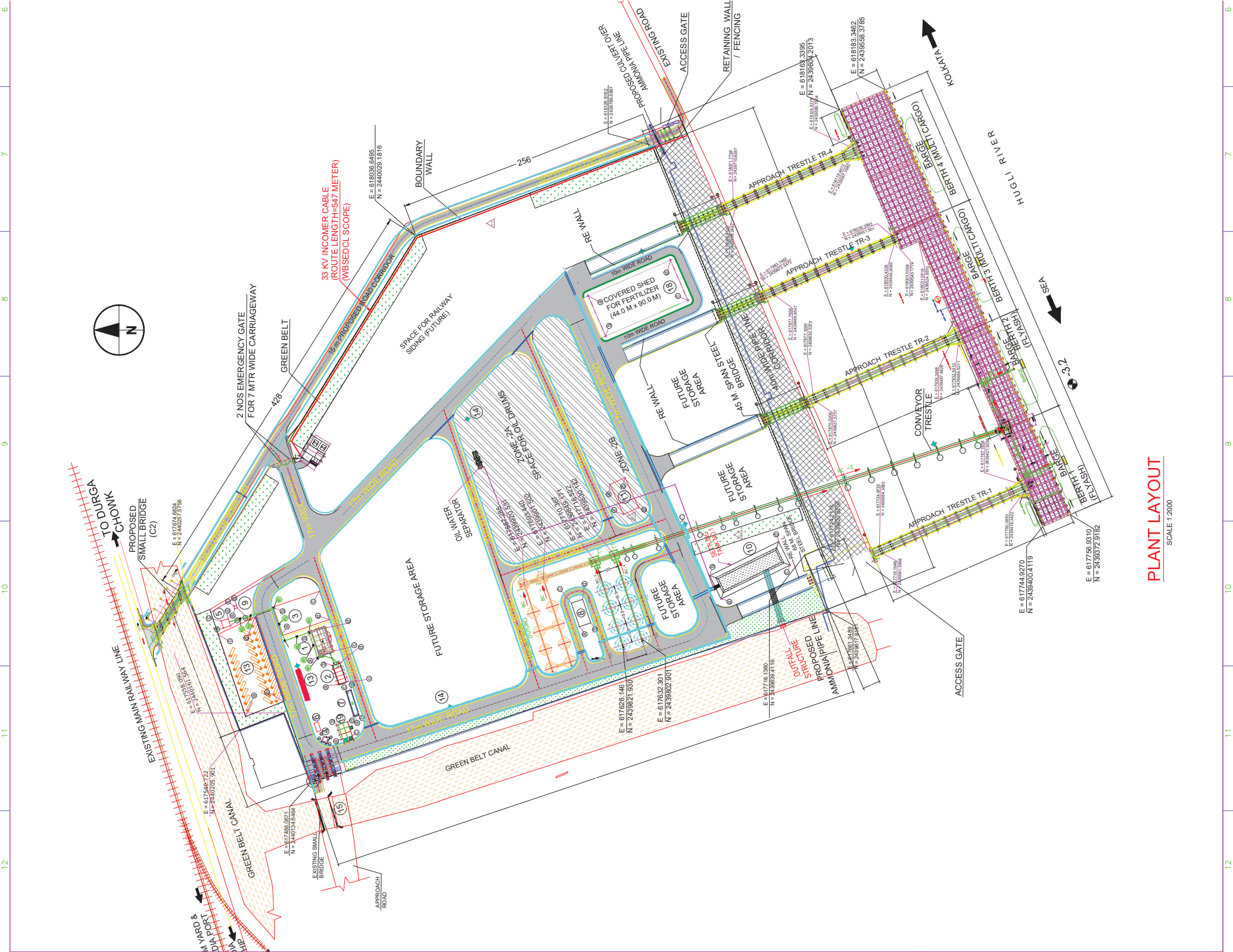

PLANT LAYOUT

SCALE 1:200

12 11 10 9 8 7 6

6 7 8 9 10 11 12

Annexure 3: Land details

This page has been intentionally left blank. Please turn over to next page.

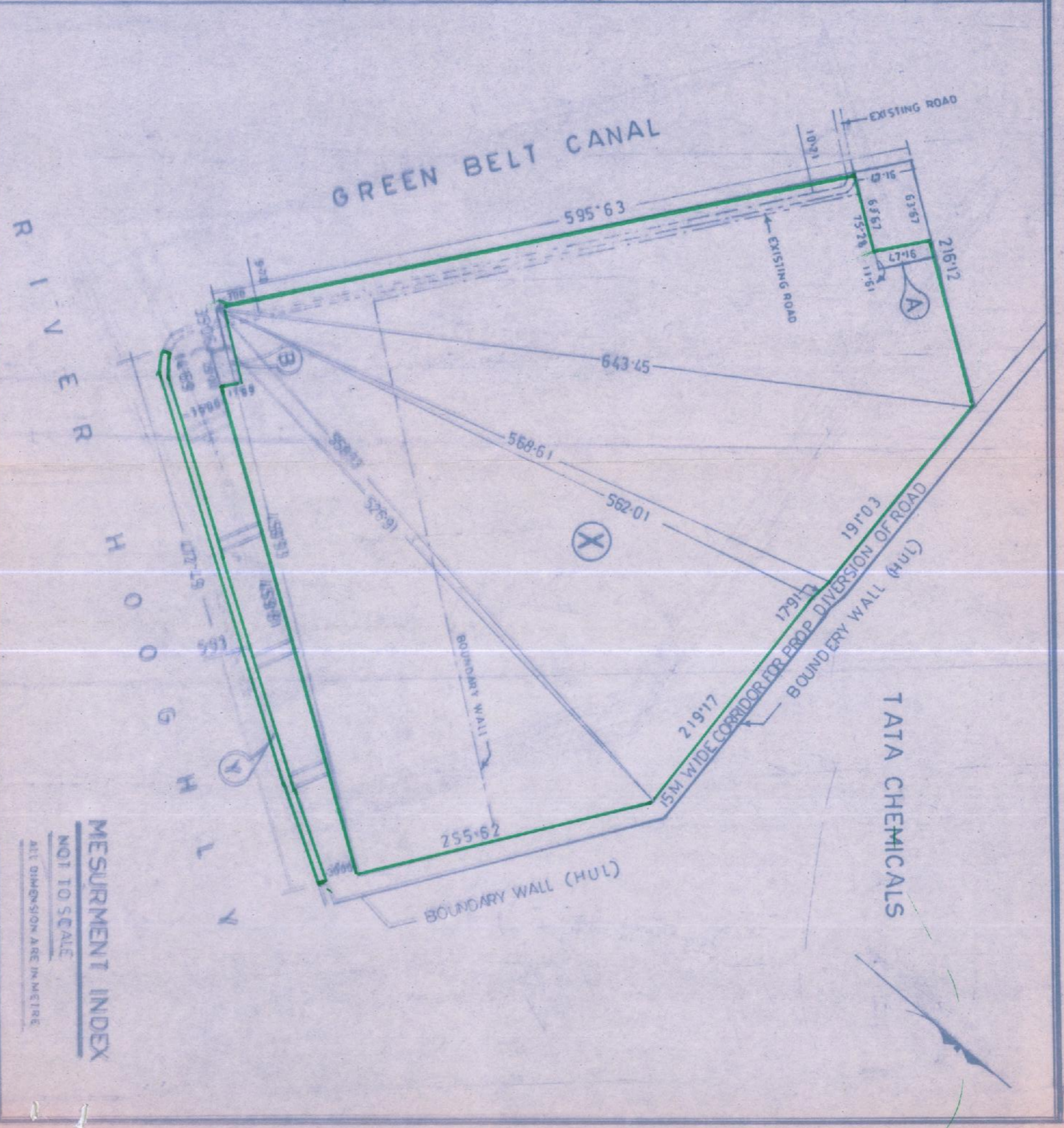
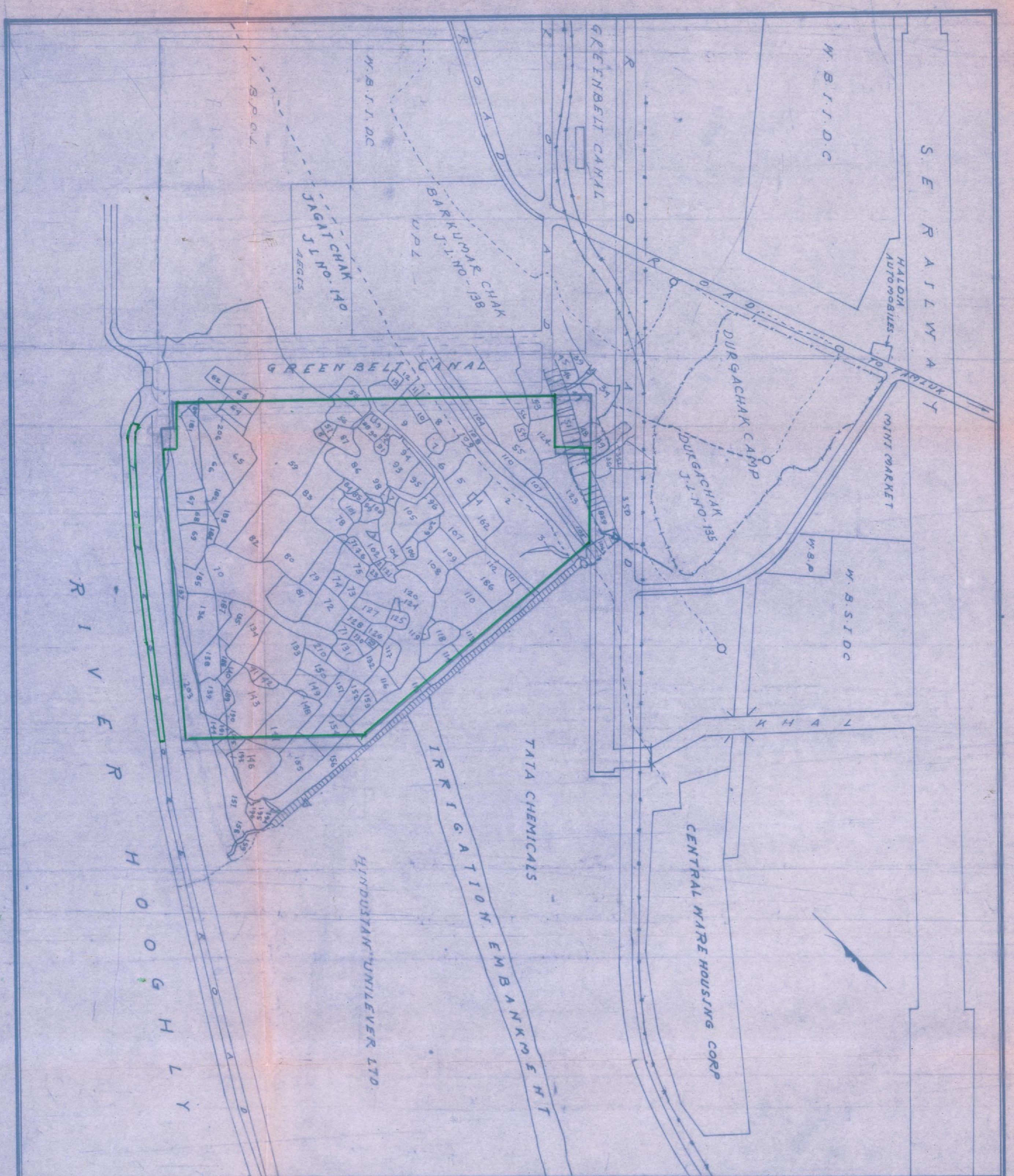

**681 KOLKATA PORT TRUST
HALDIA DOCK COMPLEX**

LEASE OF LAND IN THE INDUSTRIAL ZONE OF HALDIA DOCK COMPLEX AT HALDIA, IN MOUZA - DURGACHAK, J.L. NO. -135, BARKUMAR CHAK, J.L. NO. -138 & JAGAT CHAK, J.L. NO. -140, P.S. -SUTAHATA (PRESENTLY DURGACHAK), DIST. - MIDNAPUR (PRESENTLY PURBA MEDINIPUR).

INLAND WATERWAYS AUTHORITY OF INDIA
TO

AREA (X+Y+A-B) - 24,68,58.155 SQM (OR 61.00 ACRES)
(SHOWN IN GREEN BORDER)

MESUREMENT INDEX
NOT TO SCALE
ALL DIMENSION ARE IN METRE

DRAWN BY	T. B. Jaiswal	DRG. NO.	AD/LEASE/151
SURVEYED BY		SCALE	1:330'
CHECKED BY	S. K. Choudhary	DATED	27/08/2015

Annexure 4: Details of Terminal Administrative Building

This page has been intentionally left blank. Please turn over to next page.

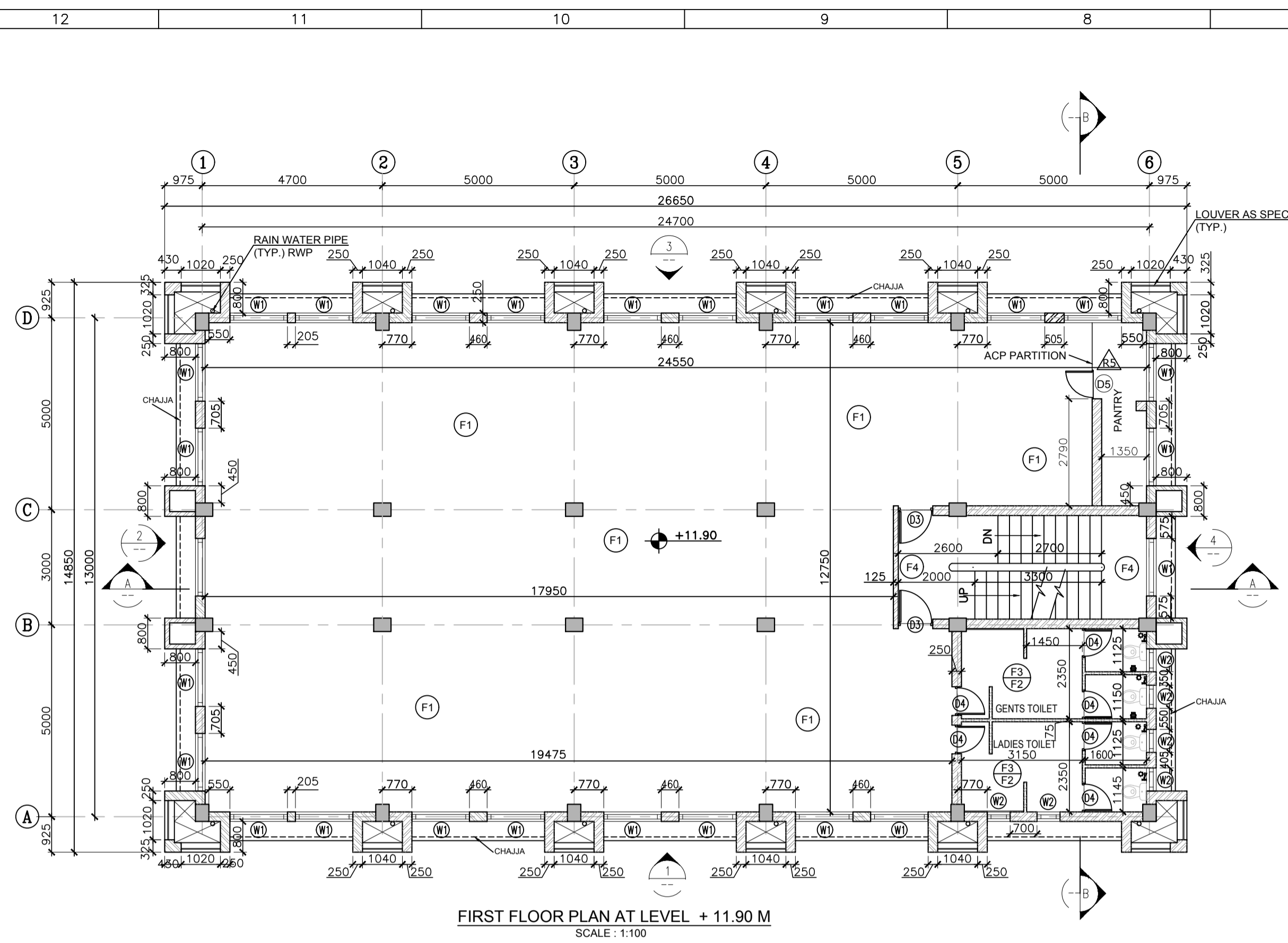

FIRST FLOOR PLAN AT LEVEL + 11.90 M
SCALE: 1:100

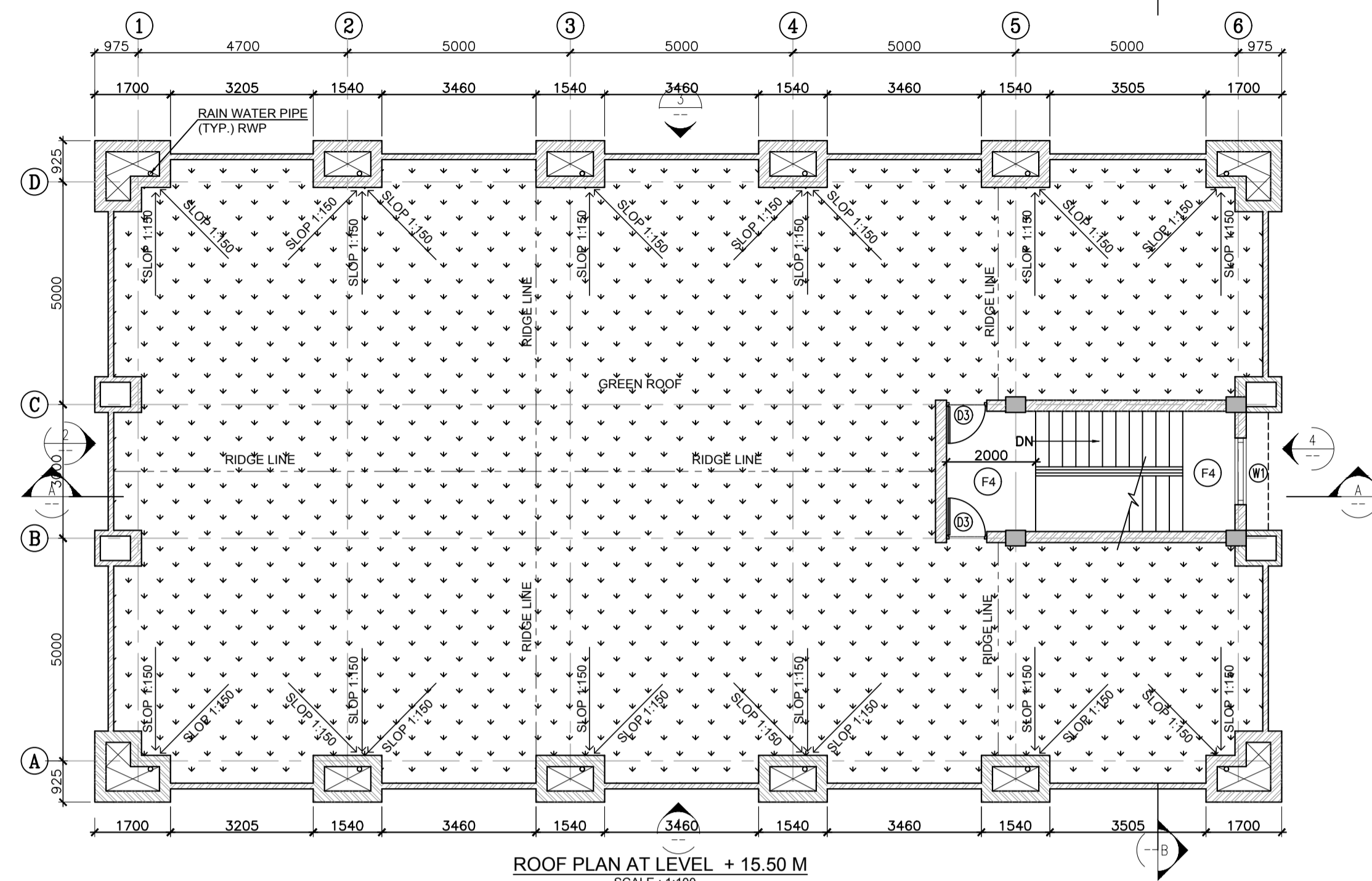

ROOF PLAN AT LEVEL + 15.50 M
SCALE: 1:100

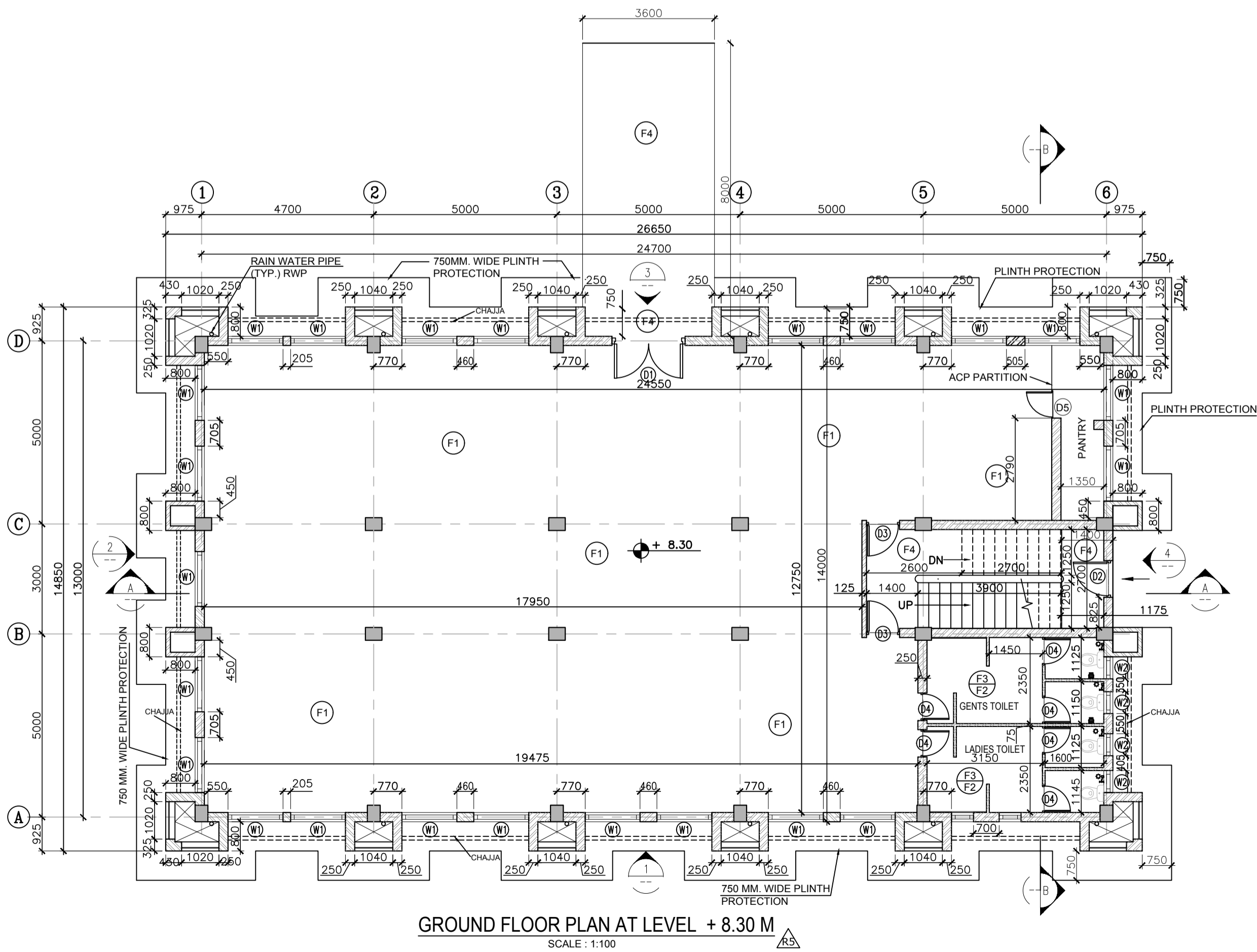

GROUND FLOOR PLAN AT LEVEL + 8.30 M
SCALE: 1:100

DOOR & WINDOW SCHEDULE

DOOR MKD	OPENING SIZE		REMARKS
	WIDTH	HEIGHT	
D1	2000	2100	DOUBLE SHUTTER STEEL DOOR
D2	1000	1800	SINGLE SHUTTER ALUMINIUM DOOR (HALF GLAZED)
D3	900	2100	SINGLE SHUTTER ALUMINIUM DOOR (HALF GLAZED)
D4	750	2100	SINGLE SHUTTER UPVC DOOR
D5	1000	2100	SINGLE SHUTTER ALUMINIUM DOOR (HALF GLAZED)
W1	1500	1200	SIDE HUNG ALUMINIUM GLAZING WINDOW WITH GRILL
W2	600	600	TOP HUNG ALUMINIUM GLAZING WINDOW

AREA STATEMENT:
 GENERAL ARRANGEMENT OF ADMINISTRATION BUILDING
 1. GROUND FLOOR AREA = 331.91 SQ. M.
 2. FIRST FLOOR AREA = 331.91 SQ. M.
 3. MUMPTY AREA = 22.45 SQ. M.

LEGEND: FLOORING
 F-1 9 MM. THK. VITRIFIED FLOOR TILES OF SOMANY CERAMICS LTD.
 F-2 9 MM. THK. ANTI-SKID VITRIFIED FLOOR TILES OF SOMANY CERAMICS LTD.
 F-3 6 MM. THK. CERAMIC WALL TILES OF KAJARIA CERAMICS LTD.
 F-4 15 MM. THK. KOTA STONE

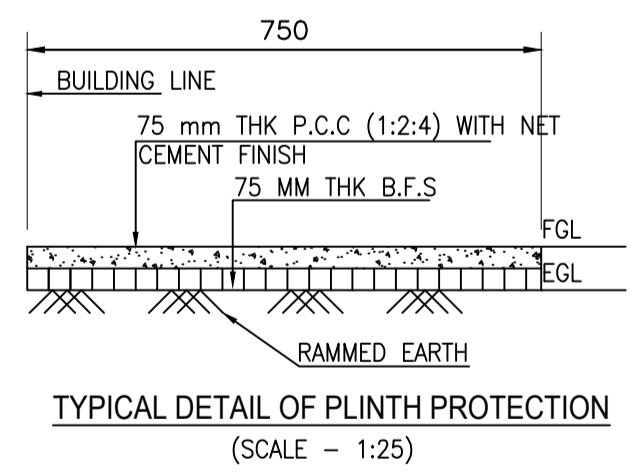
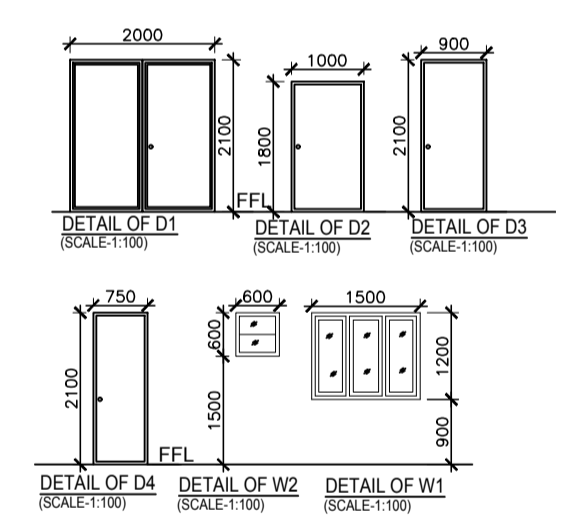

NOTES:

- ALL DIMENSIONS ARE IN MILLIMETERS UNLESS STATED OTHERWISE.
- ALL LEVELS ARE IN METERS UNLESS STATED OTHERWISE.
- ONLY WRITTEN DIMENSIONS SHALL BE FOLLOWED. THE DRAWING SHALL NOT BE SCALED.
- THIS DRAWING SHALL BE READ IN CONJUNCTION WITH ALL RELEVANT ARCHITECTURAL, STRUCTURAL AND SERVICES DRAWINGS & DISCREPANCIES/AMBIGUITIES IF ANY SHALL BE BROUGHT TO THE NOTICE OF CONSULTANTS BEFORE COMMENCEMENT OF THE WORK AT SITE.
- ALL LEVELS & DIMENSIONS STATED SHALL BE VERIFIED AT SITE & DISCREPANCIES/AMBIGUITIES IF ANY SHALL BE BROUGHT TO THE NOTICE OF CONSULTANTS BEFORE COMMENCEMENT OF THE WORK AT SITE.
- ALL EXTERNAL WALLS ARE 250MM THICK AND INTERNAL WALLS ARE 125MM THICK WITH 1:4 CEMENT - SAND MORTAR UNLESS STATED OTHERWISE. FLY-ASH BRICK SHALL BE USED AS PER GRIHA REQUIREMENT.
- ANTI TERMITE TREATMENT TO BOTTOM SURFACE OF FOUNDATION, BACK FILLING AND PLINTH FILLING SHALL BE CARRIED OUT AS PER IS-6313 (PART II) 1981
- 25mm THK DAMP PROOF COARSE TO BE APPLIED UNDER ALL BRICK WORKS AT GROUND FLOOR AS PER SPEC.
- ALL ROOFS SHALL BE TREATED WITH SIKALATEX OR EQUIVALENT AND COVERED WITH 50 MM. THK. SCREED CONCRETE WITH PROPER SLOPE TO THE RAIN WATER DOWN PIPE.
- THICKNESS OF PLASTER :
 (i) FOR EXTERNAL SURFACE : 20 MM. THK. BY 2 LAYERS WITH 1:4 & 1:2 CEMENT - SAND MORTAR.
 (ii) FOR INTERNAL SURFACE : 12 MM. THK. WITH 1:6 CEMENT - SAND MORTAR.
 (iii) FOR CEILING : 6 MM. THK. WITH 1:4 CEMENT - SAND MORTAR.
- THICKNESS OF GREEN ROOF: 150 MM.
- ALL INSIDE BUILDING SURFACES SHALL HAVE 2 COATS OF NON-VOC EMULSION PAINT AND ALL EXTERNAL SURFACES SHALL HAVE 2 COATS OF WATER BOUND WASHABLE EXTERIOR GRADE PAINT OF APPROVED BRAND & QUALITY.

CLIENT
 INLAND WATERWAYS AUTHORITY OF INDIA

EMPLOYER'S ENGINEER
 ARKITECHNO CONSULTANTS (INDIA) PVT. LTD. In Joint Venture with RCLASS TSSC-2 SYSTEMS AND SOLUTIONS PRIVATE LIMITED

CONTRACTOR
 ITD CEMENTATION INDIA LTD. GODREJ WATERSIDE, TOWER-1, OFFICE # 803, 8TH FLOOR, PLOT-5, BLOCK DP, SALT LAKE SECTOR V, KOLKATA-700091.

CONTRACTOR'S LEAD DESIGNER
 STUP Consultants Pvt. Ltd. REGISTERED OFFICE : 1004-5 RAJEEVA CHAMBERS, NARIMAN POINT, MUMBAI 400 021. OFFICE OF ORIGIN KOLKATA

M & E CONSULTANT
 Development Consultants Private Limited CONSULTING ENGINEERS 24 PARK STREET, KOLKATA-700016

PROJECT
 ENGINEERING, PROCUREMENT & CONSTRUCTION OF MULTI-MODAL IWT TERMINAL AT HALDIA, WEST BENGAL

TITLE
 ADMINISTRATION BUILDING
 GENERAL ARRANGEMENT OF ADMINISTRATION BUILDING

DESIGNED & DRAWN BY STUP

CHECKED BY STUP/ITDCem

PROOF CONSULTANT IIT Kharagpur

REVIEWED & VERIFIED BY TSSC-2

APPROVED BY IWA

DRG NO. ITD-Cem/STUP/42016DM/E/AD/ADMIN/ CS-01 (SHT-1 OF 2)

DATE 30.06.2020

SCALE AS SHOWN

DATE 30.06.2020

REV. R **SIZE** 5 A1

THIS DRAWING IS THE PROPERTY OF ITD CEMENTATION INDIA LTD. & STUP CONSULTANT PVT. LTD. IT SHOULD NOT BE USED, COPIED OR REPRODUCED WITHOUT THEIR WRITTEN PERMISSION.

REV.	DESCRIPTION	DATE	DRAWN	DESIGNED	CHKD.	FINAL CHKD.
R5	REVISED AS MARKED	30.06.20	SUS	ND	ID	ID
R4	REVISED AS MARKED	22.10.19	SUS	ND	ID	ID
R3	PARTITION WALL SHOWN FOR LIGHTING & HVAC CONSIDERATION	20.08.19	SUS	ND	ID	ID
R2	AS PER CLIENT'S COMMENTS	27.06.19	SUS	ND	ID	ID
R1	AS PER CLIENT'S COMMENTS	17.01.19	SUS	ND	ID	ID
R0	FOR APPROVAL	08.03.18	SUS	ND	ID	ID

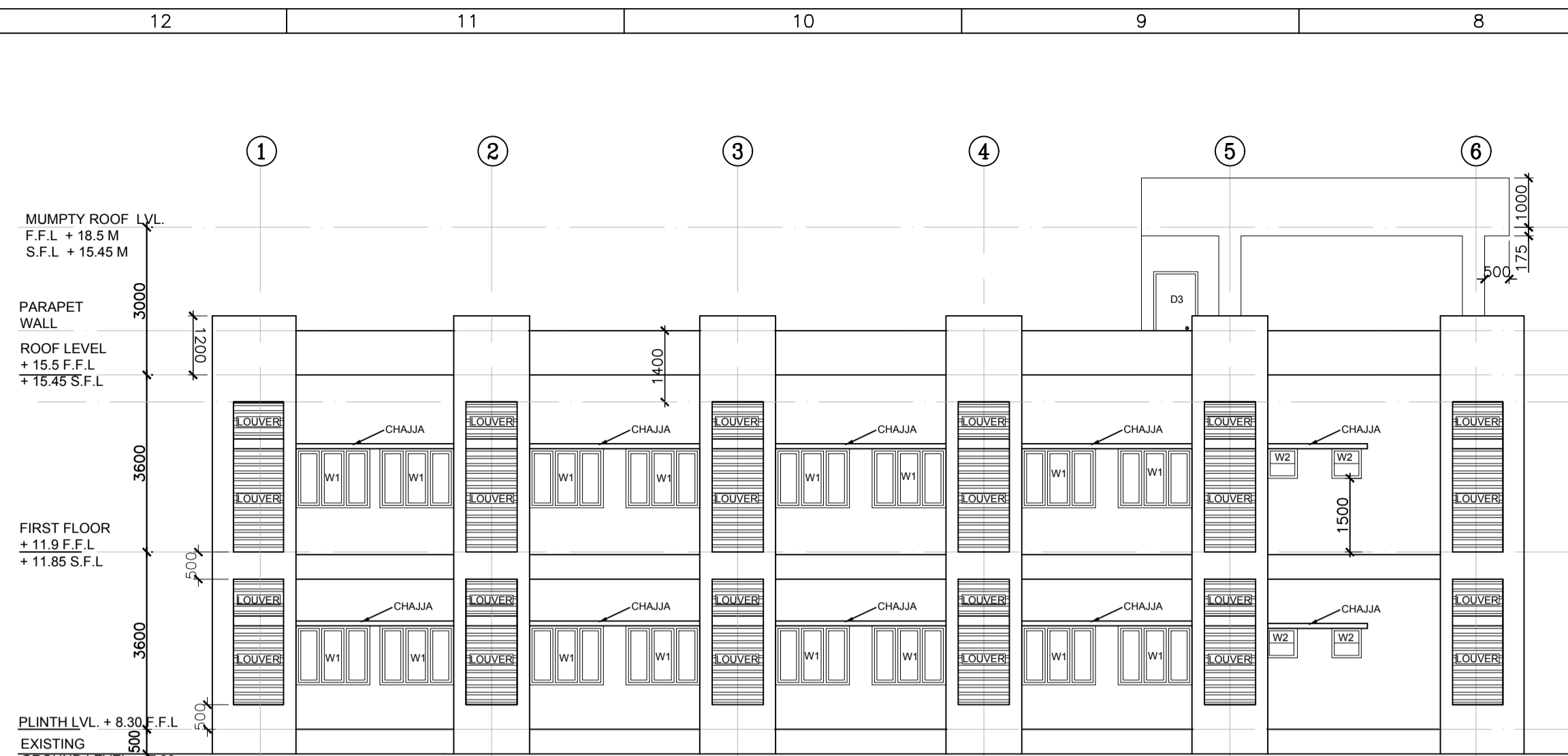

ELEVATION - 1
(SCALE 1:100)



ELEVATION - 3
(SCALE 1:100)



ELEVATION - 2
(SCALE 1:100)

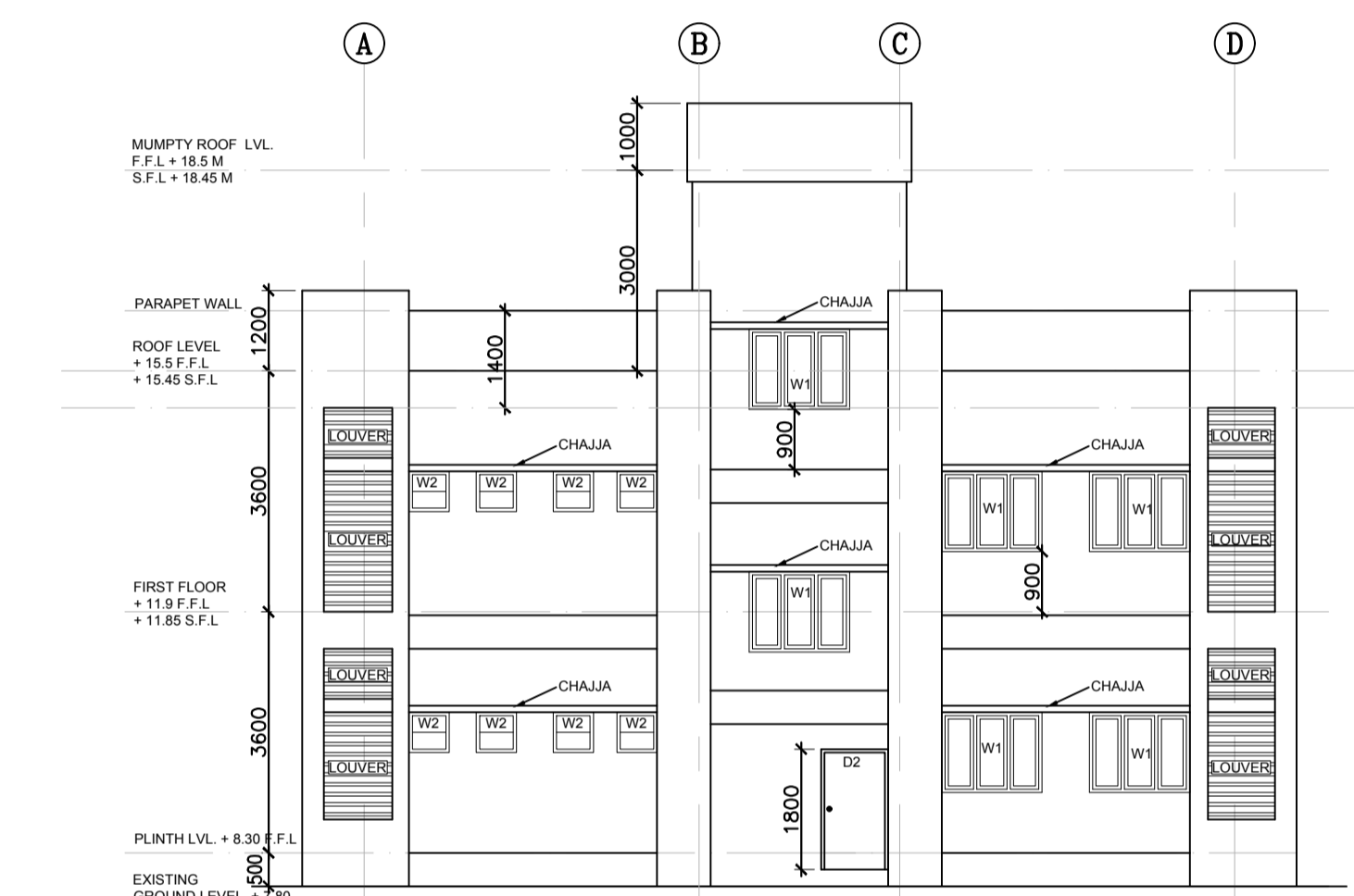

ELEVATION - 4
(SCALE 1:100)

DOOR & WINDOW SCHEDULE				
DOOR MKD	OPENING SIZE		LINTEL LEVEL	REMARKS
	WIDTH	HEIGHT		
D1	2000	2100	- 2100	DOUBLE SHUTTER STEEL DOOR
D2	1000	1800	- 1800	SINGLE SHUTTER ALUMINIUM DOOR (HALF GLAZED)
D3	900	2100	- 2100	SINGLE SHUTTER ALUMINIUM DOOR (HALF GLAZED)
D4	750	2100	- 2100	SINGLE SHUTTER UPVC DOOR
D5	1000	2100	- 2100	SINGLE SHUTTER ALUMINIUM DOOR (HALF GLAZED)
W1	1500	1200	900	SIDE HUNG ALUMINIUM GLAZING WINDOW WITH GRILL
W2	600	600	1500	TOP HUNG ALUMINIUM GLAZING WINDOW

AREA STATEMENT :-
GENERAL ARRANGEMENT OF ADMINISTRATION BUILDING

- GROUND FLOOR AREA = 331.91 SQ.M.
- FIRST FLOOR AREA = 331.91 SQ. M.
- MUMPTY AREA = 22.45 SQ. M.

LEGEND - FLOORING

F-1	9 MM. THK. VITRIFIED FLOOR TILES OF SOMANY CERAMICS LTD.
F-2	9 MM. THK. ANTI-SKID VITRIFIED FLOOR TILES OF SOMANY CERAMICS LTD.
F-3	8 MM. THK. CERAMIC WALL TILES OF KAJARIA CERAMICS LTD.
F-4	15 MM. THK. KOTA STONE

NOTES:

- ALL DIMENSIONS ARE IN MILLIMETERS UNLESS STATED OTHERWISE.
- ALL LEVELS ARE IN METERS UNLESS STATED OTHERWISE.
- ONLY WRITTEN DIMENSIONS SHALL BE FOLLOWED. THE DRAWING SHALL NOT BE SCALED.
- THIS DRAWING SHALL BE READ IN CONJUNCTION WITH ALL RELEVANT ARCHITECTURAL, STRUCTURAL AND SERVICES DRAWINGS & DISCREPANCIES/AMBIGUITIES IF ANY SHALL BE BROUGHT TO THE NOTICE OF CONSULTANTS BEFORE COMMENCEMENT OF THE WORK AT SITE.
- ALL LEVELS & DIMENSIONS STATED SHALL BE VERIFIED AT SITE & DISCREPANCIES/AMBIGUITIES IF ANY SHALL BE BROUGHT TO THE NOTICE OF CONSULTANTS BEFORE COMMENCEMENT OF THE WORK AT SITE.
- ALL EXTERNAL WALLS ARE 250MM THICK AND INTERNAL WALLS ARE 125MM THICK WITH 1:4 CEMENT - SAND MORTAR UNLESS STATED OTHERWISE. FLY-ASH BRICK SHALL BE USED AS PER GRHHA REQUIREMENT.
- ANTI TERMITE TREATMENT TO BOTTOM SURFACE OF FOUNDATION, BACK FILLING AND PLINTH FILLING SHALL BE CARRIED OUT AS PER [S-4313 (PART II) 1981]
- 25mm THK. DAMP PROOF COARSE TO BE APPLIED UNDER ALL BRICK WORKS AT GROUND FLOOR AS PER SPEC.
- ALL ROOFS SHALL BE TREATED WITH SIKALATEX OR EQUIVALENT AND COVERED WITH 50 MM. THK. SCREED CONCRETE WITH PROPER SLOPE TO THE RAIN WATER DOWN PIPE.
- THICKNESS OF PLASTER :
(i) FOR EXTERNAL SURFACE : 20 MM. THK. BY 2 LAYERS WITH 1:4 & 1:2 CEMENT - SAND MORTAR.
(ii) FOR INTERNAL SURFACE : 12 MM. THK. WITH 1:6 CEMENT - SAND MORTAR.
(iii) FOR CEILING : 6 MM. THK. WITH 1:4 CEMENT - SAND MORTAR.
- THICKNESS OF GREEN ROOF: 150 MM.
- ALL INSIDE BUILDING SURFACES SHALL HAVE 2 COATS OF NON-VOC EMULSION PAINT AND ALL EXTERNAL SURFACES SHALL HAVE 2 COATS OF WATER BOUND WASHABLE EXTERIOR GRADE PAINT OF APPROVED BRAND & QUALITY.
- KOTA STONE SHALL BE PROVIDED AT STAIRCASE LOCATION.

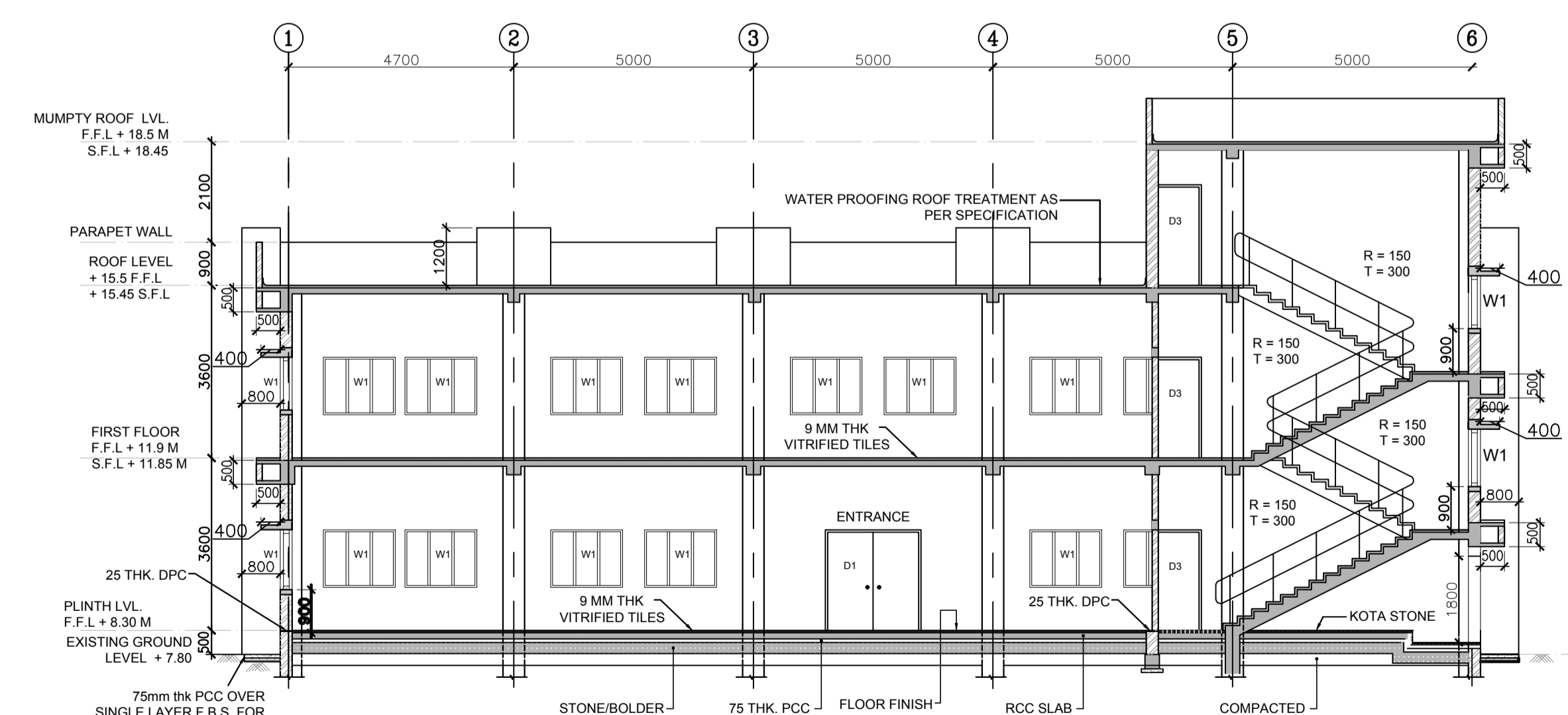

SECTION A-A
(SCALE:- 1:100)

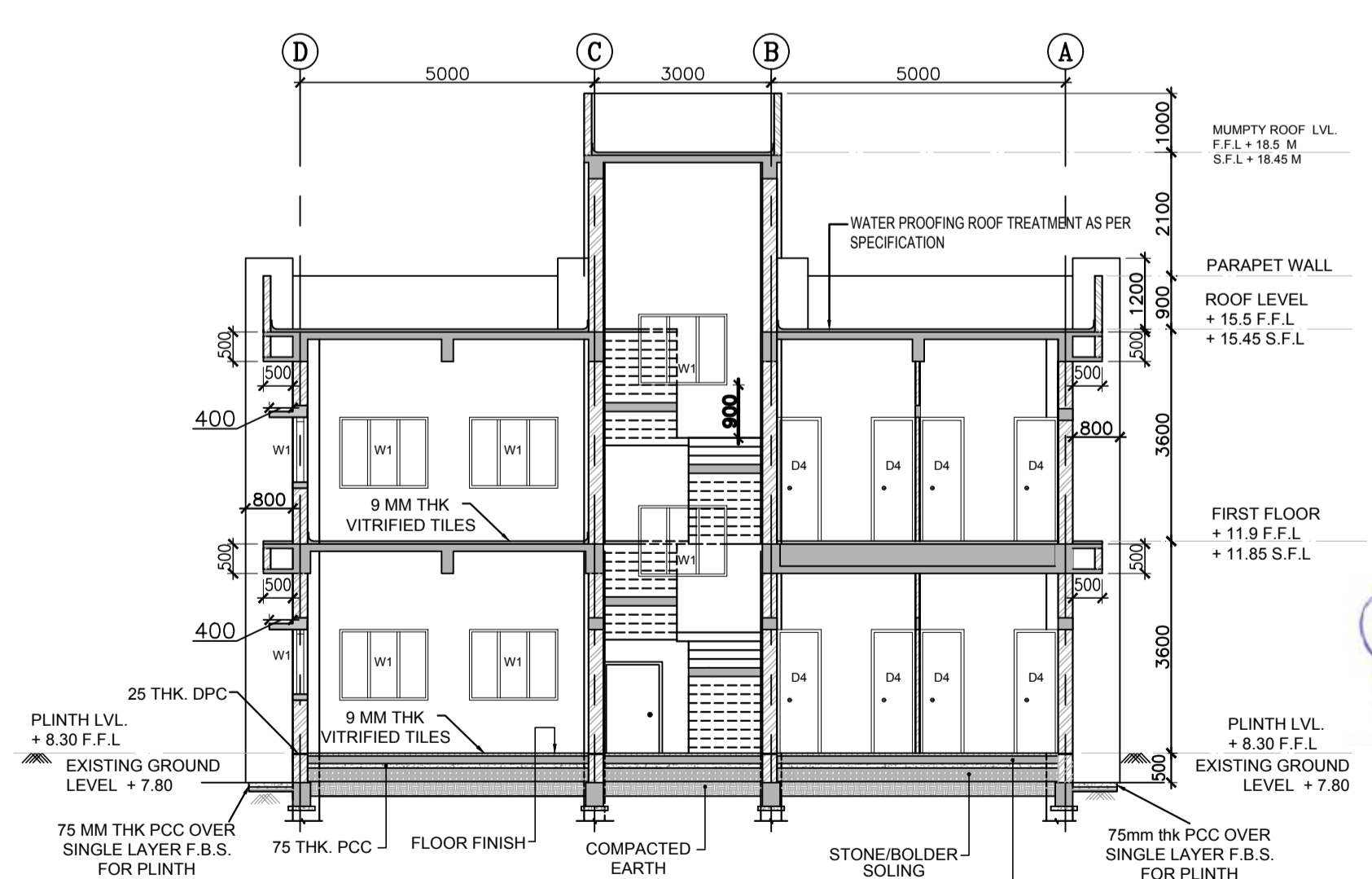

SECTION B-B
(SCALE:- 1:100)

R#	REVISION	DATE	DRAWN	DESIGNED	CHKD.	FINAL CHKD.
R4	REVISED AS MARKED	30.06.20	SUS	ND	ID	ID
R3	REVISED AS MARKED	22.10.19	SUS	ND	ID	ID
R2	AS PER CLIENT'S COMMENTS	27.06.19	SUS	ND	ID	ID
R1	AS PER CLIENT'S COMMENTS	17.01.19	SUS	ND	ID	ID
R0	FOR APPROVAL	08.03.18	SUS	ND	ID	ID
REV.	DESCRIPTION	DATE	DRAWN	DESIGNED	CHKD.	FINAL CHKD.

DRG NO. ITD-Cem/STUP/42016DM/E/AD/ADMIN/ CS-01 (SHT-2 OF 2)

THIS DRAWING IS THE PROPERTY OF ITD CEMENTATION INDIA LTD. & STUP CONSULTANT PVT. LTD. IT SHOULD NOT BE USED, COPIED OR REPRODUCED WITHOUT THEIR WRITTEN PERMISSION.

CLIENT: **INLAND WATERWAYS AUTHORITY OF INDIA**

EMPLOYER'S ENGINEER: **ARKITECHNO** In Joint Venture with **RCLASS TSSC-2**

CONTRACTOR: **ITD CEMENTATION INDIA LTD.**
GODREJ WATERSIDE, TOWER-1, OFFICE # 803, 8TH FLOOR, PLOT-5, BLOCK DP, SALT LAKE SECTOR V, KOLKATA-700091.

CONTRACTOR'S LEAD DESIGNER: **STUP Consultants Pvt. Ltd.**
REGISTERED OFFICE : 1004-5 RAHEJA CHAMBERS, NARIMAN POINT, MUMBAI 400 021. OFFICE OF ORIGIN KOLKATA

M & E CONSULTANT: **Development Consultants Private Limited**
CONSULTING ENGINEERS
24 PARK STREET, KOLKATA-700016

PROJECT: **ENGINEERING, PROCUREMENT & CONSTRUCTION OF MULTI-MODAL IWT TERMINAL AT HALDIA, WEST BENGAL**

TITLE: **ADMINISTRATION BUILDING**
GENERAL ARRANGEMENT OF ADMINISTRATION BUILDING

Datta

Annexure 5: Copy of Section 17 of the Inland Waterways Authority Act, 1985

Section 17. Levy and collection of fees and charges

(1) The Authority may, with the previous approval of the Central Government, levy fees and charges at such rates as may be laid down by regulations made in this behalf for services or benefits rendered in relation to the use of the national waterways for the purposes of shipping, navigation, infrastructural facilities, including facilities for passengers and facilities relating to the berthing of vessels, handling of cargoes and storage of cargoes.

(2) The fees and charges levied under sub-section (1) shall be collected in such manner as may be determined by regulations.

Annexure 6: HPC traffic study

This page has been intentionally left blank. Please turn over to next page.



IWT Sector Development Strategy and Business Development Study for Capacity Augmentation of National Waterway 1 from Haldia to Allahabad

Volume I: Report Part A



IWT Sector Development Strategy and Business Development Study for Capacity Augmentation of National Waterway 1 from Haldia to Allahabad

Report Part A

This report has been prepared by:

HPC Hamburg Port Consulting GmbH
Container Terminal Altenwerder
Am Ballinkai 1
21129 Hamburg,
Germany

UNICONSULT
Universal Transport Consulting GmbH
Container Terminal Burchardkai 1
21129 Hamburg
Germany

SubConsultants:

IMS Ingenieurgesellschaft mbH, Stadtdeich 7, 20097 Hamburg, GERMANY

Ramboll, The Epitome Building No.5, Tower-B, DLF Cyber Terrace Phase-III, Gurgaon-122 002, India

UNICONSULT Universal Transport Consulting GmbH

Phone: +49-40-74008 106

Fax: +49-40-322764

E-mail: u.witulski@uniconsult-hh.de

Web: www.uniconsult-hamburg.de

Copyright © by UNICONSULT Universal Transport Consulting GmbH

18 May 2016

Table of Contents

	Page
<i>List of Figures</i>	1
<i>List of Tables</i>	5
<i>List of Abbreviations</i>	10
1 Management Summary	11
Waterway & Infrastructure.....	11
Market Survey Methodology	11
Market Assessment	12
Commodity Share.....	12
Thermal Coal	12
Construction Materials.....	12
Industrial inputs	13
Agricultural inputs and Food products	13
Consumer Goods and Containers	13
Transport Forecast model.....	14
Infrastructure Cases.....	14
Transportation Costs	15
IWT Promotion and Incentives	15
Freight Market Projections.....	16
Socio Economic Advantages of Modal Shift to IWT.....	20
2 Macro-Economic Growth and Policies.....	20
2.1 Background economic growth.....	21
2.1.1 Uttar Pradesh.....	21
2.1.2 Bihar.....	24
2.1.3 Jharkhand.....	26
2.1.4 West Bengal	29
2.1.5 Madhya Pradesh	32
2.1.6 Summary.....	34
2.2 Indian Government IWT policies and subsidies.....	37
2.2.1 Background	37
2.2.2 Scheme for Incentivizing Modal Shift of Cargo (SIMSC)	40
2.2.3 Possible application of policies and subsidies	41
2.3 Policies and subsidies to the favor of IWT in Europe	42
2.3.1 The European Union Marco Polo Program.....	44
2.3.2 The EU funding program TEN-T (Connecting European Facilities CEF)	49
2.3.3 The EU funding program INTERREG IV A Upper Rhine	50
2.3.4 The EU funding program NAIADES	52
2.3.5 The EU funding projects PLATINA and PLATINA 2	54
2.3.6 Conclusions on the Marco Polo and other EU incentive programs in respect of inland waterway transport in India	56
2.4 Policies and subsidies to the favor of IWT in China.....	57
2.4.1 Modal shift from land transport to waterway transport.....	58
2.4.2 Encouraging establishment of inland waterway transport service companies.....	61
2.4.3 Encouraging recycling of ship wastes	61
2.4.4 Technological innovation of inland water vessels	63
2.4.6 Traffic control of inland water transport.....	67

2.4.7	Summary on incentives and first conclusions from the Chinese example	68
3	Regional Demand.....	70
3.1	The NW-1 hinterland.....	70
3.1.1	Haldia-Farakka sector	70
3.1.1.1	Zone 1: Kolkata-Howrah.....	70
3.1.1.2	Zone 2: Haldia.....	71
3.1.1.3	Zone 3: Durgapur-Raniganj-Burdwan.....	72
3.1.1.4	Zone 4: Rampurhat-Nalhati-Pakur-Berhampore.....	73
3.1.1.5	Zone 5: Indo-Bangladesh Protocol Route.....	73
3.1.2	Farakka-Munger sector.....	74
3.1.3	Ballia-Allahabad sector	77
3.2.1	Terminals	79
3.2.1.1	Terminal capacities.....	79
3.2.1.2	Hinterland connectivity of existing terminals	80
3.2.2	Facilities other than terminals.....	81
3.2.2.1	Storage infrastructure	81
3.2.2.2	Haldia-Farakka sector	81
3.2.2.3	Farakka-Munger sector	82
3.2.2.4	Munger-Ballia sector	82
3.2.2.5	Ballia-Allahabad sector.....	83
3.3	Special economic & industrial zones	84
3.4	Facilities and infrastructure required to enhance modal shift.....	86
3.5	Eastern Dedicated Freight Corridor.....	89
3.6	Existing transport demand	90
3.6.1	Haldia – Farakka sector.....	91
3.6.1.1	Thermal coal.....	91
3.6.1.2	Fly ash.....	92
3.6.1.3	Stone chips	93
3.6.1.4	Cement	93
3.6.1.5	Sand.....	93
3.6.1.6	Iron & steel.....	93
3.6.1.7	Fertilizer.....	93
3.6.1.8	Agro-equipment	94
3.6.1.9	Food grains and flour	95
3.6.1.10	Crude vegetable oil	95
3.6.1.11	Other raw materials	95
3.6.1.12	Consumer goods.....	95
3.6.1.13	Over-dimensional cargo (ODC).....	95
3.6.2	Farakka-Munger sector.....	96
3.6.2.1	Around Sahibganj	96
3.6.2.2	Sakrigali	96
3.6.2.3	Mirzachowk	96
3.6.2.4	Rajmahal.....	96
3.6.2.5	Pirpainti	96
3.6.2.6	Bakudi.....	97
3.6.2.7	Barharwa	97
3.6.2.8	Pakur.....	97
3.6.2.9	Baghalpur	97

	3.6.2.10	Kahalgaon.....	98
3.6.3		Munger-Ballia sector	100
	3.6.3.1	Patna	100
	3.6.3.2	Gaya.....	101
	3.6.3.3	Munger.....	101
	3.6.3.4	Barauni	101
	3.6.3.5	Barh	101
	3.6.3.6	Ballia	101
3.6.4		Ballia-Allahabad sector	102
	3.6.4.1	Coal.....	102
	3.6.4.2	Building materials.....	102
	3.6.4.3	Agricultural inputs.....	102
	3.6.4.4	Food grains and flour	102
	3.6.4.5	Edible oil	102
4		Freight Costs and Tariffs	103
4.1		Capital-cost recovery mechanism of railway system	103
4.2.2		Road.....	113
4.2.3		Inland-waterway transport.....	115
5		Regional Traffic Flows	117
5.1		Freight transport patterns.....	117
5.1.1		Haldia – Farakka sector.....	117
	5.1.1.1	Commodity movements and freight tariff rates	117
	5.1.1.2	Thermal coal.....	121
	5.1.1.3	Stone chips	121
	5.1.1.4	Cement.....	121
	5.1.1.5	Iron & steel.....	121
	5.1.1.6	Fertilizer (urea).....	122
	5.1.1.7	Food grains.....	122
	5.1.1.8	Agro-equipment	122
	5.1.1.9	Limestone	122
	5.1.1.10	Other raw materials	122
	5.1.1.11	Consumer goods.....	122
	5.1.1.12	Over-dimensional cargo (ODC).....	122
5.1.2		Farakka-Munger sector.....	124
	5.1.2.1	Around Sahibganj	124
	5.1.2.2	Sakrigali	125
	5.1.2.3	Mirzachowk	129
	5.1.2.4	Rajmahal.....	129
	5.1.2.5	Pirpainti	130
	5.1.2.6	Bakudi.....	131
	5.1.2.7	Barharwa	132
	5.1.2.8	Pakur.....	133
	5.1.2.9	Baghalpur	134
	5.1.2.10	Kahalgaon.....	137
5.1.3		Munger-Ballia sector	141
5.1.4		Ballia-Allahabad sector	142
	5.1.4.1	Coal.....	142
	5.1.4.2	Building materials.....	142

5.1.4.3	Agricultural inputs	142
5.1.4.4	Food grains and flour	142
5.1.4.5	Edible oil	143
5.1.4.6	Local hand-loom silk products.....	143
5.1.4.7	Over-dimensional cargo (ODC).....	143
5.2	Bottlenecks by transport mode and route	145
5.2.1	Railways	145
5.2.2	Roads	145
6	General Competitiveness of IWT	151
6.1	Supply chain review	151
6.3	Service attributes of IWT compared with road and rail	158
6.4	Required improvements to attract more traffic.....	163
6.5	Business development plan	165
6.5.1	Cargo services	166
6.5.2	Passenger services	169
6.5.3	Ferry services	170
6.5.3.1	Uttar Pradesh	172
6.5.3.2	Bihar	172
6.5.3.3	Jharkhand	172
6.5.3.4	West Bengal.....	172
7	IWT Competitiveness.....	174
7.1	NW-1 potential and constraints	174
7.1.1	General potential.....	174
7.1.2	Cargo sector.....	175
7.1.2.1	Haldia-Farakka sector	175
7.1.2.2	Farakka-Munger sector	176
7.1.2.3	Muner-Ballia sector	178
7.1.2.4	Ballia-Allahabad sector.....	178
7.1.3	Passenger sector.....	180
8	Cost Competitiveness	181
8.1	Cost competitiveness comparison rail against IWT.....	181
8.2	Unit cost of transportation for IWT as against rail and road.....	185
8.2.1	Case I and II: 16-tons and 24-tons capacity trucks	186
8.2.2	Case III: Rajmahal Coal Mines	188
8.2.3	External costs.....	190
9	Traffic Forecast – General.....	192
9.1	Background indicators.....	192
9.2	Impact of background economic growth on future transport demand.....	193
9.3	Freight volume growth as expected by producers and operators	194
10	Traffic Forecast – on O/D Routes.....	195
10.1	Methodology and future trends.....	195
10.1.1	Overview of the forecast modelForecast Model	195
10.1.2	Evaluation of modal shifts	197
10.1.3	Parameter assumptions used in the model.....	199
10.1.4	Volume forecasts	201
10.2	Results of traffic forecast for existing and augmented NW-1	204
10.2.1	Total cargo volumes by case	205
10.2.2	Cargo flows by original transport mode	206
10.2.3	Cargo volumes upstream against downstream flows	206

10.2.4	Volumes by cargo types.....	207
10.2.5	Cargo volumes by commodity	208
10.3	Examination of origin-destination pairs	212
10.4	IWT-cargo volumes through existing and planned major multi-modal terminals ..	213
10.4.1	Haldia Multi-modal Terminal and Sagar Island	213
10.4.2	Kolkata Garden Reach Terminal	217
10.4.3	Sahibganj Multi-modal Terminal	220
10.4.4	Patna Terminal.....	222
10.4.5	Ramnagar Multi-modal Terminal.....	225
10.4.6	Ghazipur Multi-modal Terminal	228
10.4.7	Kalughat Multi-modal Terminal.....	236
10.4.8	Tribeni transshipment terminal.....	238
10.5	Demand distribution between various transport corridors and modes	239
11	Socio Economic and Environment Benefits.....	242
11.1	Absolute and comparative benefits to environment due to the modal shift and transportation of cargo using IWT sector.....	242
12.	Annexes.....	251
	Annex 1: List of Market-Survey Interviews	252
	Annex 2: Roadside Interviews to identify Truck Loads	266
	Annex 3: Commodities identified in Haldia-Farakka NW-1 sector (tons)	269
	Annex 4: Farakka-Munger Survey Information	270
	Annex 5: Monthly Cargo Movements (tons).....	271
	Annex 6: Rail and Road Connectivity at Sahibganj.....	273
	Annex 7: Railway Freight Charges for Class 150-Type Commodity.....	274
	Annex 8: Cost comparison of O/D pairs identified during through our market survey, calculated against potential O/D pairs channeled through Ghazipur	275
	Annex 9: Potential Transshipment Cargo via Tribeni (MAC augmentation case, tons).....	276

List of Figures

	Page
Figure 1: Map of Uttar Pradesh.....	22
Figure 2: Map of Bihar.....	25
Figure 3: Map of Jharkhand	27
Figure 4: Map of West Bengal	30
Figure 5: Map of Madhya Pradesh	33
Figure 6: Progress in IWT development on national waterways.....	39
Figure 7: Marco Polo- facts and figures.....	48
Figure 8: Demarcation of Zone 1 (Kolkata-Howrah and vicinity) and Zone 2 (Haldia and vicinity)	71
Figure 9: : Haldia Multi-Modal Terminal at present	72
Figure 10 Demarcation of Zone 3 (Durgapur-Raniganj-Burdwan and vicinity)	72
Figure 11: Demarcation of Zone 4 (Rampurhat-Nalhati-Pakur-Berhampore and vicinity).....	73
Figure 12: Demarcation of Zone 5 (Indo-Bangladesh Protocol Route).....	74
Figure 13: Influence and core region-Sahibganj.....	75
Figure 14: Loading points in the influence region.....	75
Figure15: Survey area covered around Patna	76
Figure16: Survey area covered within the Ballia-Allahabad sector.....	77
Figure 17: Location of IWAI facilities in relation to potential cargo locations.....	79
Figure 18: Existing Patna terminal	83
Figure 19: Location of special economic zones	85
Figure20: Aspects enhancing modal shift from road/rail to IWT	88
Figure 21 : Course and construction progress of EDFC	89
Figure 22: Coal fields and coal-fired thermal power plants	92
Figure 23: Location of fertilizer companies	94
Figure 24: Transport and NW-1 loading stations at Bhagalpur	98
Figure25: Transport and NW-1 loading stations at Kahalgaon.....	99

Figure 26: Munger-Ballia sector with major industrial centers	100
Figure 27: Development of total traffic earnings and cargo traffic earnings (in Rs million) ...	106
Figure 28: Distribution of construction costs	107
Figure 29: Development of ordinary working expenses (in Rs million)	108
Figure 30: Development of ton-km by commodities (in million ton-km)	108
Figure 31: Distribution of %-share of ton-km by commodities in 2012/13	109
Figure 32: Development of annual earnings per ton-km	109
<i>Figure 33: Commodities moved through Haldia and Sagar Island</i>	<i>117</i>
Figure 34: Commodities moved through Haldia and Sagar	119
<i>Figure 35: Commodities moved through Kolkata-Farakka region</i>	<i>120</i>
Figure 36: Commodities moved through Kolkata and Pakur	123
Figure 37: Route map-Sakrigali to Manihari by naukas	127
Figure 38: Means of commodity transport	128
Figure 39: Severe damage inflicted due to heavy truck loads	129
<i>Figure 40: Commodities moved in Farakka-Munger Sector</i>	<i>138</i>
Figure 41: Cargo moved in the Farakka-Munger sector (tons 2015)	140
<i>Figure 42: Commodities moved in Munger-Ballia Sector</i>	<i>141</i>
<i>Figure 43: Commodities moved through Ballia-Allahabad sector (tons)</i>	<i>144</i>
Figure 44: Supply chain	151
<i>Figure 45: Determining factors in modal shift for freight transportation</i>	<i>160</i>
Figure 46: Strategic business development	166
Figure 47: Potential ro-ro ferry connections along NW-1	173
<i>Figure 48: Ferry at Kochuberia Ghat</i>	<i>173</i>
Figure 49: Map of transport cases Kolkata-Barh	182
Figure 50: Rail connection Kakinda to Bhagalpur	184
<i>Figure 51: Average depression of IWT unit costs per ton-km according to effective draft (Europe)</i>	<i>187</i>
Figure 52: Location of Rajmahal Coal Mines	189

Figure 53:	Average external costs by transport mode (in € per 1,000 tkm)	191
Figure 54:	Methodology of the forecast model	195
Figure 55:	India’s construction spendings	204
Figure 56:	Cargo volumes projected 2020-2045 – by scenario (tons).....	205
Figure 57:	<i>Cargo volumes by original transport mode before deviation (million tons)</i>	206
Figure 58:	<i>Cargo flows upstream vs downstream 2020-2045 (million tons)</i>	207
Figure 59:	Cargo volumes by type projected 2015-2045 (million tons)	208
Figure 60:	Cargo volume projection by commodity group 2015-2045 (million tons)	209
Figure 61:	Cargo volume projection by individual commodity 2015-2045 (tons).....	211
Figure 62:	Haldia MMT loaded versus unloaded cargo 2020-2045 (million tons)	213
Figure 63:	Haldia MMT - 2020-2045 cargo forecast by cargo type (million tons)	214
Figure 64:	Haldia MMT - 2020-2045 cargo forecast by commodity group (million tons)	216
Figure 65:	<i>Kolkata GRT loaded vs unloaded cargo 2020-2045 (million tons)</i>	217
Figure 66:	Kolkata GRT - 2020-2045 cargo forecast by cargo type (million tons).....	218
Figure 67:	Kolkata GRT - 2020-2045 cargo forecast by commodity group (million tons)	219
Figure 68:	Sahibganj MMT loaded versus unloaded cargo 2020-2045 (million tons).....	220
Figure 69:	Sahibganj MMT - 2020-2045 cargo forecast by cargo type (million tons).....	221
Figure 70:	Patna Terminal loaded versus unloaded cargo 2020-2045 (million tons)	222
Figure 71:	Patna Terminal - 2020-2045 cargo forecast by cargo type (million tons).....	223
Figure 72:	Patna Terminal - 2020-2045 cargo forecast by commodity group (million tons)	224
Figure 73:	Ramnagar MMT loaded versus unloaded cargo 2020-2045 (million tons)	225
Figure 74:	Ramnagar MMT - 2020-2045 cargo forecast by cargo type (million tons).....	226
Figure 75:	Ramnagar MMT - 2020-2045 cargo forecast by commodity group (million tons)	228
Figure 76:	Preferred location for potential multi-modal terminal at Ghazipur, U.P.	229
Figure 77:	Possible location for a multi-modal terminal in Ghazipur, U.P.	229
Figure 78:	Location of one or more interviews with producing units in the Allahabad-Munger sector (red dots)	231
Figure 79:	GhazipurMMT loaded versus unloaded cargo 2020-2045 (million tons).....	235

Figure 80: Ghazipur MMT - 2020-2045 cargo forecast by cargo type (million tons).....	235
Figure 81: Regional location of Kalughat Multi-modal Terminal	236
Figure 82: Possible location for an alternative multi-modal terminal at Kalughat.....	237
Figure 83: Kalughat Terminal loaded versus unloaded cargo 2020-2045 (million tons)	237
Figure 84: Kalughat Terminal - 2020-2045 cargo forecast by cargo type (million tons)	238
Figure 85: Possible location for a transshipment terminal in Tribeni, W.B.	239
Figure 86: Comparison of cargo capacity of different modes of transport.....	243
Figure 87: Energy efficiency of different modes of transport	244
Figure 88: Comparison of distances transported for one ton of freight given the same energy input	245
Figure 89: Comparison of emissions per ton-mile	245
Figure 90: Comparison analysis between road, rail and IWT emissions	246

List of Tables

	Page
Table 1: State-wise road network indicators	34
Table2: State-wise rail density (area and population)	35
Table3: State-wise length of rivers, canals and lakes, and infrastructure endowment	36
Table 4: State-wise food grain storages, cold storages, warehouses and container depots ..	36
Table 5: Focus of funding of different EU incentive and promotion programs.....	57
Table 6: Summary of incentive measures for IWT in Hunan Province.....	69
Table 7: Traffic-generating regions and the nearest location	78
Table 8: Size of existing terminals.....	79
Table 9: Nearest road and rail locations to NW-1	80
Table 10: Number of food-grain storages, warehouses and container depots (as of 31 March 2012)	81
Table 11: Coverage of food-grain storages, warehouses and container depots (by area and population)	81
Table 12: Facilities (terminals, cold storages) identified in the Haldia-Farakka sector	81
Table 13: Facilities (terminals, cold storages) identified in the Farakka-Munger sector	82
Table 14: Facilities (terminals, cold storages) identified in the Ballia-Allahabad sector.....	83
Table 15: Exporting special economic zones in West Bengal and Uttar Pradesh (examples) ..	86
Table 16: Traffic projection on EDFC (MMT/year)	90
Table 17: Feasible cargo OD-pair via Kolaghat – Fly ash	93
Table 18: Year-wise consumption, production and imports of fertilizers (billion tons).....	94
Table 19: Variable costs of rail services	105
Table 20: Choice of freight rates (valid since April 2015) in Rs per km.....	111
Table 21: <i>Railway costs for movement of cargo by cost elements (in Rs per ton-km)</i>	112
Table 22: <i>Railway costs in average per commodity for movement of cargo (in Rs Per ton-km)</i>	112
Table 23: <i>Road freight rates per region and cargo group (in Rs per ton-km)</i>	114
Table 24: Road costs for movement of cargo (Rs per ton-km)	114
Table 25: IWT costs for movement of cargo (Rs per net ton-km).....	115

Table 26:	IWT costs for movement of cargo – cost verification (Rs per net ton-km)	115
Table 27:	Commodities by origin and destination in Haldia and Sagar Island (tons)	118
Table 28:	Commodities by origin and destination in the Kolkata-Farakka region (tons).....	120
Table 29:	Destinations served from Sahibganj railway station - Stone chips and aggregate..	124
Table 30:	Origin of commodities unloaded at Sahibganj railway station	125
Table 31:	Feasible cargo OD-pair via Sahibganj - Stone chips and aggregates	125
Table 32:	Destinations served from Sakrigali railway station - Stone chips and aggregates ..	126
Table 33:	Destinations served from Mirzachowk railway station - Stone chips and aggregates 129	
Table 34:	Destinations served from Rajmahal railway station - Silica sand	130
Table 35:	Destinations served from Pirpainti railway station – Coal	131
Table 36:	Destinations served from Bakudi railway station - Stone chips and aggregate	132
Table 37:	Destinations served from Barharwa railway station - Stone chips and aggregate..	132
Table 38:	Destinations served from Pakur railway station - Stone chips and aggregate	133
Table 39:	Destinations served from Pakur railway station – Coal.....	133
Table 40:	Origin of cement unloaded at Bhagalpur Railway Station	134
Table 41:	Origin of rice unloaded at Bhagalpur Railway Station.....	135
Table 42:	Origin of wheat unloaded at Bhagalpur Railway Station	136
Table 43:	Origin of fertilizer unloaded at Bhagalpur Railway Station	137
Table 44:	Feasible cargo OD-pair via Bhagalpur - Fertilizer	137
Table 45:	Destinations served from Kahalgaon Thermal Power Station railway siding.....	138
Table 46:	Coal provided to Kahalgaon Thermal Power Station railway siding.....	138
Table 47:	Fertilizer provided to Katihar Railway Station	138
Table 48:	Commodities by origin and destination in Farakka-Munger sector (tons).....	139
Table 49:	Commodities by origin and destination in Munger-Ballia sector (tons)	141
Table 50:	Commodities by origin and destination in Ballia-Allahabad sector (tons)	144
Table 51:	Total road length of NW-1 riparian states versus national (km/'000 km ²).....	146
Table 52:	Total road length of NW-1 riparian states versus national (% km/'000 heads).....	146

Table 53:	Important commodities divertible onto NW-1 as identified through the Consultants' market survey	149
Table 54:	Comparison of investment cost by mode in India (Rs)	157
Table 55:	Modal comparative operating costs in India.....	157
Table 56:	Comparison of freight costs by mode and commodity in NW-1 area (Rs).....	158
Table 57:	SWOT-analysis IWT	161
Table 58:	SWOT-analysis Rail.....	162
Table 59:	SWOT-analysis Road	163
Table 60:	Identified IWT limitations and remedial measures for NW-1	164
Table 61:	Important commodities via NW-1 - multi-modal transport parameters and associated costs	168
Table 62:	Potential and constraints of commodities transported on NW-1.....	176
Table 63:	Potential and constraints of commodities transported on NW-1.....	177
Table 64:	Potential and constraints of commodities transported on NW-1.....	178
Table 65:	Comparison of freight tariff levels of road, rail and IWT along NW-1 (Rs/ton-km)	181
Table 66:	Costs and earnings per trip for road transport of coal/cement between Kolkata and Barh	182
Table 67:	Costs and earnings per trip for rail transport of coal/cement between Kolkata and Barh	183
Table 68:	Costs and earnings per trip for IWT transport of coal/cement between Kolkata and Barh	183
Table 69:	Costs and earnings per trip for IWT transport of fertilizer between Kakinada and Bhagalpur	183
Table 70:	Costs and earnings per trip for IWT transport of coal/cement between Kolkata and Barh	184
Table 71:	<i>Comparison of transport modes concerning transport of 3,000 tons of cargo between Kolkata and Barh</i>	185
Table 72:	Unit cost comparison of transport modes (Rs per ton-km)	186
Table 73:	Comparison freight tariffs and costs on Haldia-Farakka sector (Case I: 16 tons per truck)	188
Table 74:	Comparison freight tariffs and costs on Haldia-Farakka sector (Case II: 24 tons per truck)	188

Table 75:	Comparison of transport cost of different supply chain between Rajmahal and Varanasi	190
Table 76:	Average external costs by mode (in € per 1,000 tkm).....	191
Table 77:	State-wise installed generating capacity of electricity.....	193
Table 78:	Freight elasticities with respect to GDP	193
Table 79:	Growth expectations of commodity volumes.....	194
Table 80:	Transport model scenariosModel Scenarios.....	196
Table 81:	Criteria for modal shift.....	199
Table 82:	Parameter Assumptions.....	199
Table 83:	<i>Earliest consideration of NW-1 term-inals for forecast calculation (per time block)</i>	<i>201</i>
Table 84:	<i>Forecast growth rates – Weighting of specific and general market expectations by year</i>	<i>202</i>
Table 85:	Real GDP and population forecast India (annual %-change).....	202
Table 86:	General market growth factors for traffic forecast (2015-2045).....	203
Table 87:	Cargo volumes projected 2020-2045 – by scenario (tons)	205
Table 88:	Cargo flows by original transport mode before deviation (MAC, million tons).....	206
Table 89:	Cargo flows upstream vs downstream – development 2020-2045 (MAC, million tons)	207
Table 90:	Cargo volumes by type projected 2015-2045 (MAC, million tons)	208
Table 91:	Cargo volume forecast 2015-2045 by commodity group (MAC, million tons).....	209
Table 92:	Cargo volume forecast 2015-2045 by individual commodity (MAC, tons)	210
Table 93:	Important commodities via NW-1 & respective growth rates	212
Table 94:	Haldia MMT - 2020-2045 forecast by loaded versus unloaded cargo (MAC, million tons)	213
Table 95:	Haldia MMT - 2020-2045 cargo forecast by cargo type (MAC, million tons)	214
Table 96:	Haldia MMT - 2020-2045 cargo forecast by commodity groups (MAC, million tons).....	215
Table 97:	Kolkata GRT - 2020-2045 forecast by loaded versus unloaded cargo (MAC, million tons) .	217
Table 98:	Kolkata GRT - 2020-2045 cargo forecast by cargo type (MAC, million tons).....	218
Table 99:	Kolkata GRT - 2020-2045 cargo forecast by commodity groups (MAC, million tons)	218
Table 100:	Sahibganj MMT - 2020-2045 forecast by loaded versus unloaded cargo (MAC, million tons)	220

Table 101: Sahibganj MMT - 2020-2045 cargo forecast by commodity groups (MAC, million tons) .	221
Table 102: Patna - 2020-2045 forecast by loaded versus unloaded cargo (MAC, million tons)	222
Table 103: Patna Terminal - 2020-2045 cargo forecast by cargo type (MAC, million tons).....	223
Table 104: Patna Terminal - 2020-2045 cargo forecast by commodity groups (MAC, million tons) ..	223
Table 105: Ramnagar MMT - 2020-2045 forecast by loaded versus unloaded cargo (MAC, million tons).....	225
Table 106: Ramnagar MMT - 2020-2045 cargo forecast by cargo type (MAC, million tons).....	226
Table 107: Ramnagar MMT - 2020-2045 cargo forecast by commodity groups (MAC, million tons)	228
Table 108: Detail of Trucks/Cargo at Ghazipur Route (number of trucks per 24-hour day).....	233
Table 109: Ghazipur Terminal - 2020-2045 forecast by loaded versus unloaded cargo (MAC, million tons).....	234
Table 110: Ghazipur Terminal - 2020-2045 cargo forecast by cargo type (MAC, million tons)	235
Table 111: Kalughat Terminal cargo forecast, 2020-2045 (MAC, tons)	238
Table 112: Tribeni transshipped cargo volume forecast, 2020-2045 (MAC, tons)	239

List of Abbreviations

BSSDC	Bihar State Sugar Development Corporation
CFS	Container Freight Station
CO ₂	Carbon Dioxide
€	Euro
AdCOM	Advisory Committee
CNY	Chinese Yuan
crore	10,000,000
DG	Director General
dwt	dead weight ton
e.g.	example given
EA	Executive Agency
ECL	Eastern Coalfields Ltd
EIA	Environmental Impact Assessment
EU	European Union
ExBoard	Executive Board
GDP	Gross Domestic Product
Grt	gross registered ton
GRT	Garden Reach Terminal
IFFCO	Indian Farmers Fertilizer Corporation
INEA	Innovation and Networks Executive Agency
IR	Indian Railways
IWAI	Inland Waterway Authority of India
IWT	Inland Waterway Transport
KhSTPP	Kahalgaon Super Thermal Power Station
Km	Kilometer
LAD	least available depth
lakh	100,000
Lbs	Pound
LNG	Liquefied Natural Gas
LR	Low Rate
M&R	Maintenance and Repair
MCOM	Management Committee
MMT	million metric tons
MMT	Multi-modal Terminal
MoS	Motorways of the Sea
MRO	Maintenance-Repair-Overhaul
MW	megawatt
NH	National Highway
NOX	Nitrogen Oxide
NTDPC	National Transport Development Policy Committee
ntkm	net ton-kilometer
NTPC	National Thermal Power Corporation
NW	National Waterway
ODC	Over-Dimensional Cargo
PM	Particulate Matter
PMO	Prime Minister's Office
PRC	People's Republic of China
R&D	Research & Development
RIS	River Information Services
ro-ro	roll-on/roll-off
Rs	Indian Rupee
RSV	River-Sea Vessel
SCM	Supply-Chain Management
SCR	Selective Catalytic Reduction
SH	State Highway
SME	Small or Medium Enterprise
SOX	Sulfur oxides
SEZ	Special Economic Zone
TEN-T	Trans-European Network for Transport
TEU	Twenty-foot Equivalent Unit (container of 20 feet length)
TS	Technical Secretariat
U.P.	Uttar Pradesh
USA	United States of America
VAT	Value-Added Tax
VTMS	Vessel Traffic Management System
W.B.	West Bengal

1 Management Summary

Waterway & Infrastructure

The Ganga-Bhagirathi-Hooghly river system from Haldia to Allahabad declared as National Waterway-1 (NW-1) in 1986 is of national significance passing through four states of Uttar Pradesh, Bihar, Jharkhand, and West Bengal. The waterway is potentially serving the major cities of Haldia, Howrah, Kolkata, Tribeni, Katwa, Behrampur, Farakka, Rajmahal, Sahibganj, Bhagalpur, Patna, Ballia, Buxer, Ghazipur, Varanasi and Allahabad, their industrial hinterlands, and several industries located along the Ganga basin. Moreover the National Highway -2 (NH-2), the erstwhile Grant Trunk Sher Shah Suri Marg from Amritsar to Kolkata runs parallel to the waterway from Allahabad onwards and then crosses the waterway at Varanasi. Additionally the waterway runs nearly East West from Allahabad to Farakka horizontally dividing the states of UP and Bihar and North south from Farakka to Haldia.

The waterway is planned to be developed with 45m width from Haldia to Varanasi. The Least Available Depth (LAD) is being developed stretch wise Haldia to Tribeni 4m, Tribeni to Barh 3m, Barh to Ghazipur 2.5m and Ghazipur to Varanasi 2.2m. Based on the market study Multimodal Terminals are being constructed at Varanasi, Ghazipur, Kalughat, Sahebganj, Tribeni and Haldia. Ten number Ro-Ro terminals have also been proposed.

Market Survey Methodology

The river system serves richly endowed natural reserve areas as well as a large number of industrial units comprising thermal power plants, iron & steel plant, sugar mills, cement industry, small scale industries etc. The market data has been collected using primary survey by conducting road-side interviews and producer interviews covering 100km on either side of the waterway. The data has been cross verified using the secondary data sourced from users, ports, railway sidings and relevant websites. For conducting survey and analysing the data the consultants divided waterway in four sectors namely Haldia - Farakka, Farakka - Mungher, Mungher- Ballia, Ballia - Allahabad.

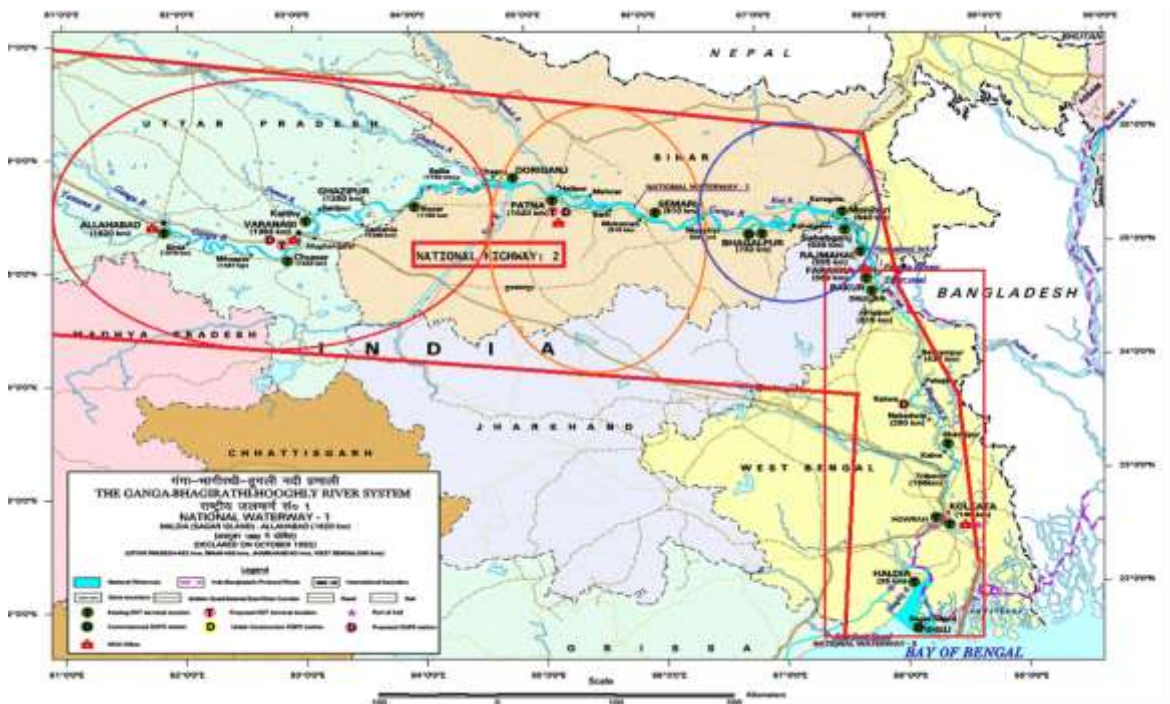

Market Assessment

National Waterway 1, Ganges-Bhagirathi–Hooghly river system passes through the states of Uttar Pradesh, Bihar, Jharkhand and West Bengal, a distance of about 1,620 km, serving nearly 42 traffic regions, between Allahabad and Haldia (Sagar). Major ports such as Haldia and Kolkata and important cities like Kolkata, Patna, Varanasi and Allahabad fall under its primary hinterland. The river system serves richly endowed natural reserve areas as well as a large number of industrial units comprising thermal power plants, iron & steel plant, sugar mills, cement industry, small scale industries etc.

In order to undertake survey and analyse the cargo that has a potential to pass through the region and to be handled at the future multi-modal terminals has been broken down into the following seven commodity groups (containing the major commodities):

1. Thermal coal (imported high-calorie coal, domestic low-calorie coal), coking coal and pet coke;
2. Construction materials (stone chips, cement, sand, steel coils/wires/girders);
3. Agricultural Inputs (fertilizer (urea), poultry feed, agro equipment);
4. Foodstuff (sugar, wheat, corn, rice, flour, vegetable oil, other foodstuff);
5. Industrial inputs (steel/iron, manganese ore, spirits, fly ash, limestone, plastics, paper);
6. Consumer goods (motor bikes, cars, general container loads); and
7. Project cargo (ODC Over-Dimensional Cargo, heavy lifts, spare parts, etc).

Commodity Share

During the survey it has been found that the Construction materials and Thermal Coal are the two major commodities that are being moved along and in the vicinity of NW-1 and has great potential to shift on the waterway for transportation. The freight share of the two commodities in 2045 is expected to be 30.81% for coal and 35.72% for natural aggregates. The other commodities that has substantial share are Industrial inputs and Agricultural inputs.

Thermal Coal

The forecasted growth of transportation of coal by IWT is likely to be initially at 8.76% till 2020 on the coal demand by existing and upcoming thermal power plants, due to the policy to use more domestic coal and reduce import of coal, the share of domestic coal in transportation of coal will increase 8.76% in 2020 to 30.81% in 2045. However the coking coal shall continue to be imported for steel plants etc.

Coal has two sources i.e. imported and from domestic mines, the imported coal comes from Indonesia, South Africa to Sandheads/Paradeep and is then transported by rail and road to thermal plants. Eleven existing thermal power plants on either side of the river between Haldia and Allahabad and ten more upcoming power projects have boosted the prospect of the NW-1 like never before for transporting imported coal to power stations. With the use of fly ash in the manufacturing of cement and in the construction of roads, the NW-1 could be utilized for evacuation of fly ash from power plants on its banks. With 11 more power plants scheduled to be commissioned within the next five to eight years the demand for coal transportation will further increase. However with the change in policy of the government to reduce use of imported coal in Thermal Plants the demand shall reduce over time till the production of domestic coal is sufficient to meet the demand.

Construction Materials

Over nine and half million metric tonnes [9.97MMT] of the construction material forming about 45% of the freight is likely to be moved on the National Waterway-1. The government is focussing on the development of Eastern India and more so with regards to infrastructure development in terms of road network etc.. Moreover with the focus on economic growth of the rural India the construction of houses etc. along the agrarian belt on both sides of waterway will further push up the demand of construction material. It is expected that the demand on IWT freight on account of construction material is likely to increase from 45% to 50%.

Stone Chips

Stone chips is one of the major commodity in construction material group, it is presently being moved from Sahebganj to Patna upstream on the waterway and to Nepal, Purnia away from the waterway. From Pakur the stone chips is being transported to meet the demands upto Sagar downstream on the waterway. Presently about 1million Metric Tonnes of Stone chips is being moved ex Sahebganj the numbers shall increase with construction of Ganga Path at Patna, Construction of new bridges across the Ganges, development of port at Sagar and GDP growth of rural India along the Ganges-Bhagirathi river basin.

Cement

Cement is another commodity component of construction material. Cement has been moving along the waterway for last five years though in very small quantity. With Cement plants and grinding units of Jaypee Cement at Chunar and Ambuja Cement at Farakka and Sankrail on the National Waterway-1 and Grinding Units, plants of Shree Cement at Aurangabad, ACC cement at Tekaria in UP, Kalyanpur Cement Plant in Rohtas and upcoming cement dumps of Ultratech and ACC cement the likelihood of transportation of cement on National Waterway-1 is to increase at rate of about 5.5% till 2025. Though the demand of cement movement along the waterway has been about 300MT in the past months.

Industrial inputs

The major industries in the hinterland of NW-1 are cement manufacturing plants. The main industrial inputs being fly ash, gypsum, limestone in the manufacturing of cement. With eleven existing thermal power plants on either side of the river between Haldia and Allahabad and ten more upcoming power projects sufficient fly ash will be available for cement plants and NW-1 is ideal for evacuation of fly ash from power plants to the cement manufacturing units.

Agricultural inputs and Food products

The river basin of the Ganges is fertile and is extensively used for agriculture, resulting in significant transport demand. Fertilizer is required for the crops in the area, hence a number of fertilizer distribution centres are situated on the NW-1. The fertilizer plants are located in Phulpur about 50km from Allahabad, Haldia and Paradip. Hence there is substantial potential for transporting fertilizers from plants located near Allahabad and Haldia to various locations in Uttar Pradesh, Bihar and West Bengal. The agro-products like Food Grain, Flour and Sugar though in small parcel size are moved on regular basis from the Allahabad – Farraka belt to Kolkata and is potential for shifting to IWT on smaller vessels or aggregation would be required at the terminals.

Consumer Goods and Containers

With an AAGR of about 13%, container traffic growth is expected to be relatively high during the initial years, driven by the general economic development as well as increasing containerization. The latter effect is likely to be significant in particular after opening of multimodal terminals along NW-1, which will facilitate the multi-modal transport in the corridor. It should be noted, however, that the mentioned effects will decrease over time. As a consequence, the Consultants calculated the AAGR to decline to 3% by the year 2045 based on decreasing elasticities. The distance from Inland Container Depots at Delhi NCR to Nhava Sheva and Kolkata is same but more than 60% of containers move through Nhava Sheva even if the export is towards Far East. Most of the import cargo originating from Far East is also imported through Nhava Sheva in spite of distance to Delhi from Singapore through Kolkata being 1500Km less than the distance to Delhi via Mumbai. Hence if container handling facilities and turnaround time improve at Kolkata/Haldia the growth of containerisation is bound to accelerate.

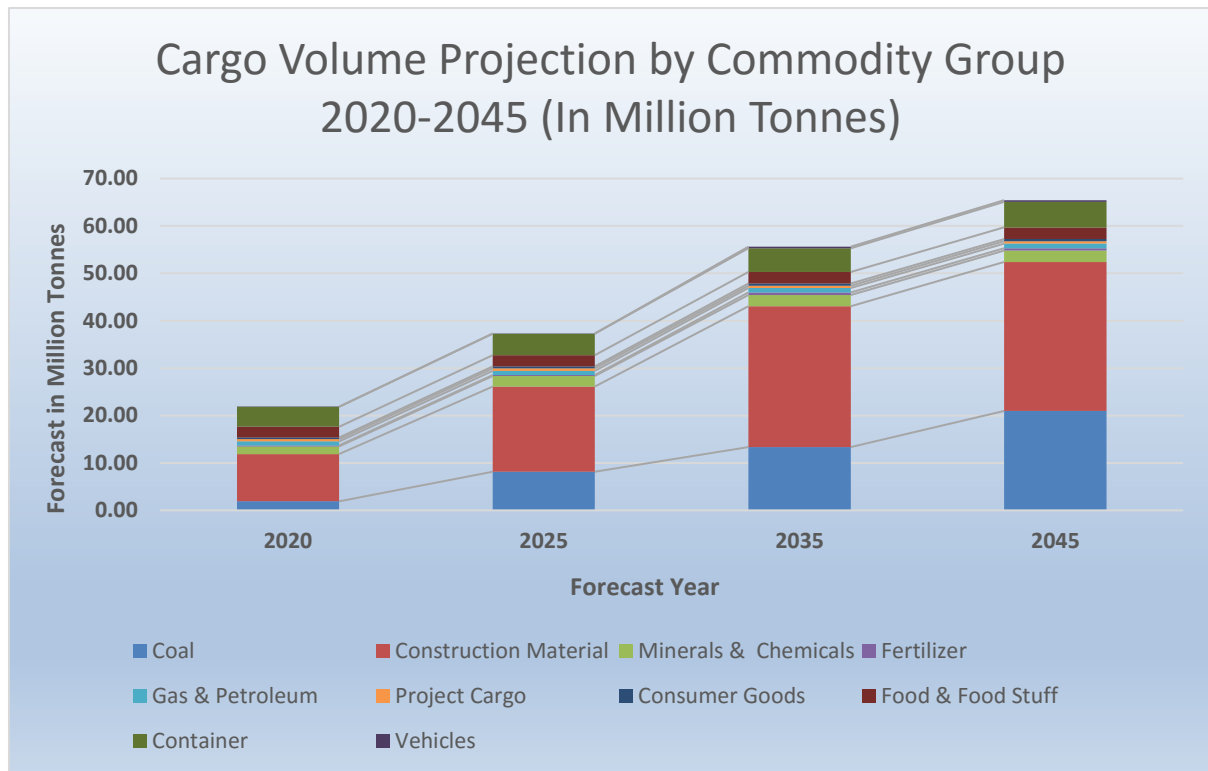

Transport Forecast model

The data collected has been analysed for potential model shift using a transport forecast model that analyses traffic between over 500 Origin Destination pairs. The potential model shift to waterway has been selected by comparison of modal costs of transportation of commodities between the different modes including cost of first mile connectivity and last mile connectivity @1.5 times the normal costs for road transport, handling costs applied at Kolkata and inventory costs. The mathematical model is dependent on seven [7] Commodity Type, twenty six [26] Origin - Destination pairs, Least Available Depth [LAD] for different stretches, Vessel Size according to LAD and commodity growth potential based on population growth, industrial and economic growth of the region and country. The mathematical model calculates the market forecast for years up to 2045.

The Consultant's integrated Transport Forecast Model adapted to the Indian context calculated future freight flows on the basis of origin-destination pairs (O/D-pairs) collected during their market survey from late July until early November 2015. As a result of the market survey and calculations through an adapted transport forecast model, the Consultants established cargo potential volumes on the NW 1 by three different scenarios:

1. Low augmentation: 9.21 MMT for the year 2020 and about 13.68 MMT for the year 2045;
2. Medium augmentation: 21.89 MMT for the year 2020 and about 65.45 MMT for the year 2045;
3. Full augmentation: 21.89 MMT for the year 2020 and about 128.77 MMT for the year 2025.

Infrastructure Cases

Low Augmentation Case (Base Case): No changes or improvements on infrastructure and IWT policy/promotion: LAD of 3 m until Farakka; LAD of 2,50 m until Patna, LAD of 1,50-2,00 m until Varanasi; LAD of 1,00-2,00 m until Allahabad but Construction of Multi-modal Terminals at Haldia,

Kolkata, Sahibganj, Patna and Varanasi is assumed and Regular growth rates in the IWT based on macroeconomic growth rates and regional economic development

Medium Augmentation Case: 3 m water depth until Barh; 2.50 m until Ghazipur and 2.2 m LAD until Varanasi with Supporting IWT policy from the national and state government and implementation of IWT promotion concept to market the quality and services of IWT. Availability of financial incentive for the promotion of IWT along with development of terminals and Ro-Ro facilities.

Full Augmentation Case: Major changes and improvement on the NW1 river infrastructure (dredging, weirs, and locks): LAD until Patna of 3.00 m; LAD until Varanasi 2.50 m with Supporting IWT policy from the national and state government and implementation of IWT promotion concept to market the quality and services of IWT. Availability of financial incentive for the promotion of IWT The full augmentation case is based on a larger least available depth (LAD) of the waterway upstream of Patna.

The cost of dredging to attain and maintain depth of 2.5m up to Varanasi is exorbitantly high and same did not seem to be economically viable. Also the low augmentation (base) assumes an improvement of the river navigation and the existence of new multi modal terminals on the NW 1, but does not consider any of the intended additional supporting promotion and incentives policy of the government, hence the study provides data and analyses for medium augmentation case.

Transportation Costs

The model has assumed 300 working days, commodity based rates for road, rail and waterway transport with speeds of 20km for road and rail and 7km for water transport taking in account all delays and average night halts. The Consultants developed rates by considering provision of rates that cover the generated costs per ton-kilometer on the one side, and seem to be competitive to the rates of the other transport modes on the other side. Often times a price advantage of NW-1 shipments is levelled out by additional costs, as inland-waterway transport cannot offer door-to-door services where producers and/or users are not located directly on the waterway. Instead, pre- and onward carriage is usually required to cover for the 'last mile' with cost implications arising from additional cargo handling.

Normally Coal and iron ore are supposed to be trucked by road only on short distances, mainly from the mines to the rail sidings. Feeder routes would then carry the coal or iron ore from the rail sidings to the trunk routes. The trunk routes would carry the minerals long distances, usually between distant states. Close to the destination, feeder routes would finally move the materials from the trunk route to the rail siding at the power or steel plant.

However, the Consultants' market survey established that large volumes are being trucked on Indian roads over large distances. Opportunities will therefore open up when intermodal services are available at the planned multi-modal terminals (MMTs). For some companies a MMT would provide immense advantages for their commodities on the NW-1, as origins and destinations of their cargoes lay exactly on the NW-1 route. Roll-on/roll-off facilities for heavy lift and ODC cargo should be provided which will surely offer a lot of opportunities to meet the requirement for shipping such commodities along the NW-1 and NW-2. Perspectives for utilization of the NW-1 are thus very good, once the waterway has been dredged to a sufficient depth.

IWT Promotion and Incentives

A comparative overview of European Union (EU) incentive and development programs to initiate inland-waterway transport indicates the wide range of instruments, which was deemed to be necessary for a mature EU transport industry, infrastructure and market driven forces deciding on which transport mode will be chosen to serve the market. Another comparative overview of the Chinese incentive and development programs to initiate and support inland-waterway transport indicates the wide range of instruments, which was deemed to be necessary for a mature transport industry and infrastructure. It also indicates the engagement of the national ministries when it comes to rules and regulations. The

Indian IWT transport market is currently in a less mature stage. Obviously, the question on the quality of infrastructure needs to be primarily solved prior to discussing similar instruments which are applied in highly developed IWT markets and infrastructures. Availability of barges is major concern in IWT sector in India Chinese example of supporting the barging trade given below is a good case for India to follow.

Summary of incentive measures for IWT in Hunan Province

Incentive Name	Kinds of Incentive	Max Co-financing	Applicant	Relevant authority	Requirements	Fund Source
Barge Standardization	Co-financing of modern demonstration vessels	(1) CNY 630,000 – CNY 1,400,000 For LNG depending on the total power of engine and date of completion; (2) CNY 300 per gross ton multiplied by ship-type coefficient for HEE (Higher Energy Efficiency) vessels	Ship owner	HWTAB	Specifications of newly-built vessels required by certain regulations	The Ministry
Inland vessel technology innovation	Co-financing of reconstructing or dismantling unqualified vessels	(1) CNY 1,000 per ton multiplied by the vessel-age coefficient and the vessel-type coefficient for vessel dismantling (2) CNY 600 per gross ton for the reconstruction of unqualified single-hull vessels	Ship owner	HWTAB	Un-qualified vessels banned to sail by certain regulations	60% from Ministry, 40% from Provincial government
Waste Collection	Co-financing of reconstruction	Up to 100% subject to a cap (CNY 75,000 for cargo vessel)	Ship owner	HWTAB	Installation of sewage tank and sewage treatment unit	60% from Ministry, 40% from Provincial government
Set-up of IWT-related enterprises	corporate income tax relief	Fixed 15%	Logistic company operated in ports	Tax Bureau	Qualified as Hi-tech-related company	
Modal shift from road transport to waterway transport	No specific incentive measures for individual players identified					
Traffic control and navigation management						

Note: Traffic control and navigation management system: AIS and RIS system are all under construction. There is a draft regulation on this area. Deployment of base stations of AIS system has been completed in Hunan Province.

Exchange rate Chinese Yuan/Renminbi (CNY): Indian Rupee (Rs) 1 CNY : 10,2 Rs

Freight Market Projections

The freight market projection for Medium Augmentation Case of infrastructure development with LAD stated above, channel width of 45m, construction of 6 MMT and 10 Ro-Ro jetty pairs is shown below:

Commodity	2020	2025	2035	2045
Coal	1.92	8.12	13.39	20.98
Construction Material	9.97	17.97	29.71	31.43
Minerals & Chemicals	1.61	2.26	2.35	2.4
Food & Food Stuff	2.26	2.38	2.46	2.48
Others	6.12	6.59	7.72	8.16
Total	21.88	37.32	55.63	65.45

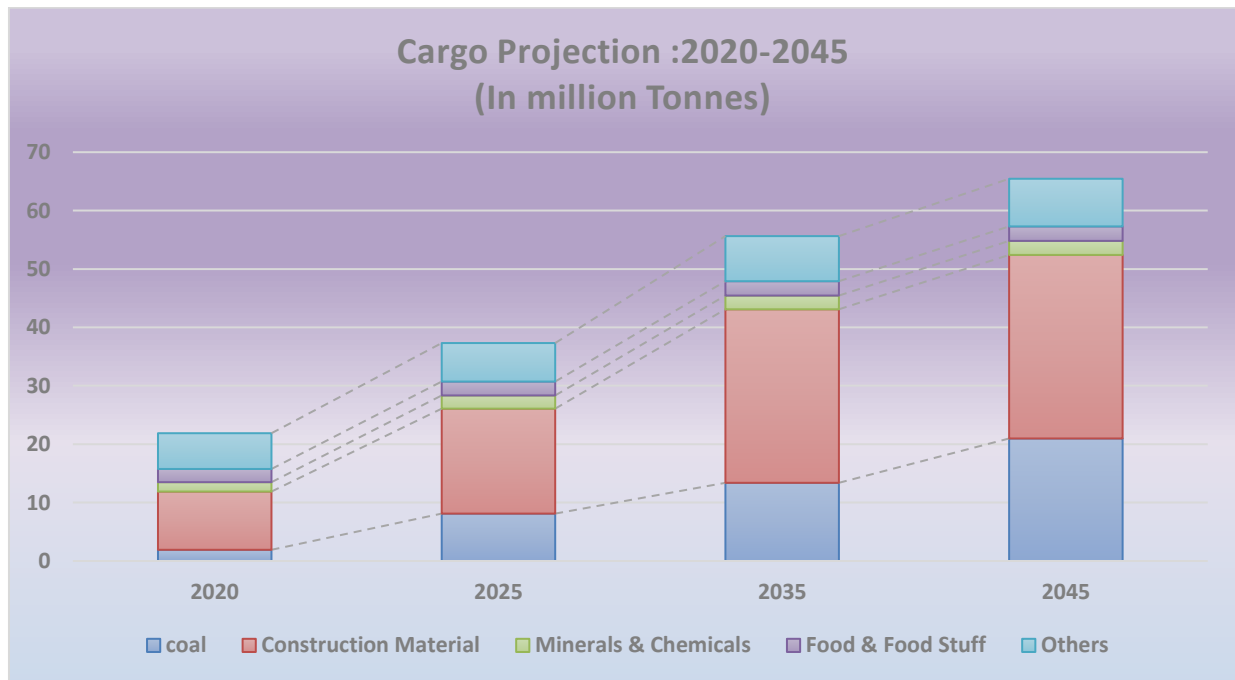

The Consultants have divided the National Waterway – 1 in following sectors:

Sector 1 :	Haldia/Kolkata-Farakka-Haldia/Kolkata
Sector 2 :	Farakka-Sahibganj-Farakka
Sector 3 :	Sahibganj-Patna-Sahibganj
Sector 4 :	Patna-Varanasi-Patna
Sector 5 :	Varanasi-Allahabad-Varanasi

The sector wise cargo projections for the medium augmentation case is shown below:

Exit Sector	3				4			
Entry Sector	2020	2025	2035	2045	2020	2025	2035	2045
1	1.47	8.80	12.16	12.49	3.98	5.87	5.93	6.25
2	0.00	0.40	0.50	0.51	0.00	0.99	1.34	1.36
3	5.12	8.17	10.73	12.08	2.33	2.55	2.94	3.00
4	0.10	0.10	0.11	0.11	1.59	1.70	1.77	1.80
5	0.00	0.00	0.10	0.10	0.00	0.00	1.32	1.35

Exit Sector	3				4				5			
Entry Sector	2020	2025	2035	2045	2020	2025	2035	2045	2020	2025	2035	2045
1	1.47	8.80	12.16	12.49	3.98	5.87	5.93	6.25	0.02	0.02	0.08	0.08
2	0.00	0.40	0.50	0.51	0.00	0.99	1.34	1.36	0.00	0.00	0.00	0.00
3	5.12	8.17	10.73	12.08	2.33	2.55	2.94	3.00	0.00	0.00	0.00	0.00
4	0.10	0.10	0.11	0.11	1.59	1.70	1.77	1.80	0.00	0.00	0.02	0.02
5	0.00	0.00	0.10	0.10	0.00	0.00	1.32	1.35	0.00	0.00	0.00	0.00

The important commodities divertible from other nodes to IWT sector is outlined in the table below:

Important commodities divertible onto NW-1 as identified through the Consultants' market survey

Commodity Type	Cargo Type	Current Transport Mode	Origin	Destination	Distance [km]	Estimated Travel Time [days]	Volume 2014 [tons]	Growth expected by Producer (%)	Freight Costs per ton per km [Rs/ton/km]	Freight Rate [Rs/ton]	Value of Time [Rs/ton]	Generalised Cost [Rs/ton]
Coal	Dry Bulk	Road	Haldia HDC	Partapgarh	941	2.0	30,000	8	6.50	6,116.5	3.4	6,119.9
Fly Ash		IWT	Durgapur (W.B.)	Narayanganj/Bangladesh	925	5.5	807,000		1.12	1,036.0	11.8	1,047.8
Iron Ore		Rail	Barauni (Bihar)	Haldia	574	1.2	10,200	10	2.18	1,251.3	2.6	1,253.9
Lime Stone		Road	Kolkata	Allahabad	800	1.7	2,571	5	3.00	2,400.0	6.6	2,406.6
Sand		Road	Mangalhat	Kolkata	352	0.7	73,500		3.45	1,214.4	2.9	1,217.3
Stone Chips		Road	Sakrigali	Gauthamsthan, Bihar	389	0.8	179,200		3.45	1,342.1	3.2	1,345.3
Plastic Granules	Bagged	Road	Kanpur (U.P.)	Kolkata	1,160	2.4	6,300	5	3.65	4,234.0	5.2	4,239.2
Grain		Road	Fatuwa	Haldia	628	0.9	50,000	0	4.00	2,512.0	104.7	2,616.7
Cement		Road	Varanasi	Patna	269	0.6	1,000	10	4.20	1,129.8	2.2	1,132.0
Fertilizer		Rail	Vishakapatnam	Katihar Railway Station	1,290	2.7	23,400		1.50	1,935.0	20.1	1,955.1
Steel	Neo-bulk	Road	Fatuwa	Kolkata	536	0.7	150,000		4.00	2,144.0	44.7	2,188.7
Petroleum		Rail	Numaligarh/Assam	Haldia	1,442	3.0	24,138	10	2.57	3,705.9	6.4	3,712.4
Logs & Wood		Road	Faizabad	Kolkata	878	1.8	3,120	10	3.30	2,897.4	7.3	2,904.7
Textiles		Road	Kolkata	Sultanpur	830	1.7	7,200	3	5.00	4,150.0	74.7	4,224.7
Project Cargo		Road	Fatuwa	Kolkata	536	0.7	80,000		4.00	2,144.0	357.3	2,501.3
Statues		Road	Chunar	Kolkata	692	1.4	40,000	5	4.90	3,390.8	62.3	3,453.1
Paper		Road	Karnataka	Kolkata	2,200	4.6	4,286	5	3.60	7,920.0	198.0	8,118.0
Food		Gen. Cargo	Road	Kolkata	Allahabad	790	1.6	8,400	5	7.00	5,930.0	10.6
Containers	Container	Road	Kolkata	Varanasi	582	1.2	972,000	10	10.52	6,120.5	104.8	6,225.2
Vehicles	Ro-Ro	Road	Delhi	Kolkata	1,500	3.1	27,000	5	46.67	70,005.0	333.9	70,338.9

Source: Consultants' Market Survey, August-October 2015

Infrastructure Constraints for Current Use and Further Development of NW 1

The major constraints for the current use and further development of National Waterway No. 1 can be summarized as follows:

- The target depths (Least Available Depth – LAD) proclaimed by IWAI for the maintenance of NW-1 (year 2014/15: 1.5 m – 3.0 m) could not be reached during recent years, at least during the last weeks of the lean season that ends mid of June, due to a lack of dredging and bandalling capacity. Thus, these target depths are not reliable for the shipping community throughout the year. Especially on the upper stretch of NW 1, upstream of Patna (km 955 – km 1,620), the minimum water depth of the fairway has been in the range between 0.8 m and 1.5 m during recent years, making the transport of goods with vessels with a minimum draft of 2.0-2.5 m uneconomic or even impossible.
- The fairway width on NW 1 of 45 m and the existence of bends with a critical radius of less than 600 m on some stretches of the waterway hinder the economic use of 2,000 – 2,500 dwt cargo vessels or pusher/barge convoys.
- Farakka lock with one chamber only, processing times of 40 minutes to half a day and no processing during night and weekends makes shipping through this lock uneconomic.
- HOWE / HR Wallingford identified at least 89 potential navigationally significant obstructions that might hinder navigation on NW 1, such as bridges with insufficient clearance heights and/or widths, power transmission lines crossing the waterway, etc.
- IWAI maintains 20 floating terminals and several RCC jetties along NW 1 for handling of cargo vessels, tourist vessels and other IWT vessels. The length of the floating terminals of 35 – 70 m limits berthing of vessels. Most of the terminals have no areas for storage of goods or open storage areas, which makes protected storage of goods impossible. Only Patna and Sahibganj terminals are equipped with handling equipment, which means that unloading/loading of cargo vessels on all other terminals has to be done with ship's gear or manually.
- The River Information System (RIS), which improves safety of navigation and makes the use of navigation marks and of pilots more and more obsolete, has yet not been realized upstream of Farakka. The application of RIS on board of vessels navigating on NW 1 is voluntary (except for ODC vessels) and costs for purchase of equipment and software obviously hinder that all cargo and passenger vessels are equipped with this system.
- Night navigation aids are provided solely on the stretch between Tribeni and Jangipur (Km 193- KM 505) and shall be extended up to Varanasi, thus 24 hours safe navigation is actually possible only on 1/3 of the waterway.
- The greater part of the vessels and barges operating on NW 1 have a fully laden draft of 3 – 4 m, which means that at least upstream of Farakka lock they cannot be operated with the maximum cargo load of 2,500 tons. Pushed convoys that would allow the same maximum cargo load with a draft of 2.0 – 2.5 m are today not used for cargo transport on NW 1.
- Vessels and Push Tug Barge Flotilla is required to be designed to carry maximum cargo safely and efficiently in different stretches of National Waterway-1. The stretch between Haldia to Tribeni, Tribeni to Farakka, Farakka to Barh, Barh to Ghaziabad and Ghaziabad to Varanasi and Varanasi to Allahabad are different in characteristics with regards to LAD, Vertical Clearance, Bend Radius, width and Currents.
- The engineering interventions for augmenting capacity is being independently studied by Howe Consortium.

Socio Economic Advantages of Modal Shift to IWT

Without doubt the modal shift towards Inland Water Transport brings down logistic and fuel consumption costs and also bears social cost benefits from decongesting roads and minimizing road accidents. According to the Planning Commission's Total Transport System Study by RITES, cost for air pollution by SO_x or particles vary considerable between Road (Rs. 0.202 per ton-km); rail (Rs 0.0366 per ton -km) and IW Shipping (Rs. 0.03 per ton-km). Accident cost are counted as Rs. 0.062 per ton-km for road transport and Rs 0.001 per ton-km for rail transport, whereas such cost are negligible for IWT.

Socio-Economic Environment Benefits generated by IWT [Year]					
	Unit	Forecast 2020	Forecast 2025	Forecast 2035	Forecast 2045
Sagar Island, Central & Northern India + Nepal (NW-1)					
Total Traffic (MAC)	Ton-Km	73765,77,955	125793,42,377	182988,21,109	216056,20,214
Reduction in Air Pollution	Rs.	9966,91,642	16996,66,903	25329,27,699	29803,88,117
Reduction in Accident Cost	Rs.	3706,78,059	6321,20,509	9420,17,253	11084,31,571
Reduction in Noise	Rs.	201,13,302	342,99,388	511,14,644	601,44,424
Reduction in CO2 Emissions	Rs.	2402,79,044	4097,49,939	6106,29,629	7185,01,870
IWT Operating Cost Savings	Rs.	17721,84,158	30221,21,018	45037,14,242	52993,28,683
Value of Time versus Rail	Rs.	12,50,232	21,32,031	31,77,258	37,38,544
Total Benefits	Rs.	34011,96,436	58000,89,788	86435,80,725	101705,33,208

Source : HPTI, 2016

2 Macro-Economic Growth and Policies

Inland Waterway Transport (IWT) hinges on the specific transport demand of a region to be served. Transport is a function of the amount of goods and products as well as of its sources and destinations. The more vibrant a region in its the production and consumption of goods and products is the more transport services are offered, preferable meeting the market demands in terms of transport quality. The cargo structure, volumes and the transport network defines the utilization on IWT.

The first sub-chapter provides a first overview about the regions and cities which are located in the four states along the Ganges River. It shall prepare a first introduction into the question of a future market for the IWT on the NW-1.

Apart from market-driven factors, the integration, consideration and attention received of the IWT mode by the governmental policy plays a significant role when it comes to its development and success. It is universally recognized that transport of goods and passengers is crucial for sustained economic growth and modernization. Adequacy of this vital infrastructure is an important determinant of the success of a nation's effort in diversifying its production base, expanding trade and linking together resources and markets into an integrated economy. It is also necessary for connecting villages with towns, market centers and in bringing together

remote and developing regions closer to one another. Transport, therefore, forms a key input for production processes and adequate provision of transport infrastructure and services helps in increasing productivity and lowering production costs.

The next subchapters shall describe what government macro-economic policies and subsidies on IWT currently exist in India.

Although IWT is one of the oldest modes of transport in historical terms, its relevance was diminishing to the same extent as to the relevance of railway and truck transportation has increased throughout the previous century. This development has taken place in many other economies and countries all over the world. Since a number of decades, the importance of this environmental friendly mode of transport has been put on the agenda by national, European and international political bodies. Because of the well-known system relevant characteristics of this mode, other economies have developed a set of policies and instruments to promote the development of IWT.

Examples shall be given from IWT incentive and development programs in Europe as well as in China. This comprehensive description provides an overview on possible instruments and measures and shall prepare the ground for best practice approaches with examples given on national and European governmental policies and subsidies which are applied in other economies in the *“Strategy for Development IWT Sector” Part C* to be delivered at a later stage.

2.1 Background economic growth

2.1.1 Uttar Pradesh

Uttar Pradesh (U.P.) is located in the northern region India, spread over 240,928 km². The state shares its borders with Nepal and states like Bihar and Jharkhand. The state also borders the capital of India New Delhi along with the newly formed state of Uttarakhand (carved out of the state of Uttar Pradesh in the year 2000 and covers now about 7% of India's total area). It has been one of the oldest states in the country and boasts of some of the biggest tourist destinations in the country. The GDP growth at constant prices leveled around 6% in the last years. The capital of U.P. is Lucknow.

Figure 1: Map of Uttar Pradesh

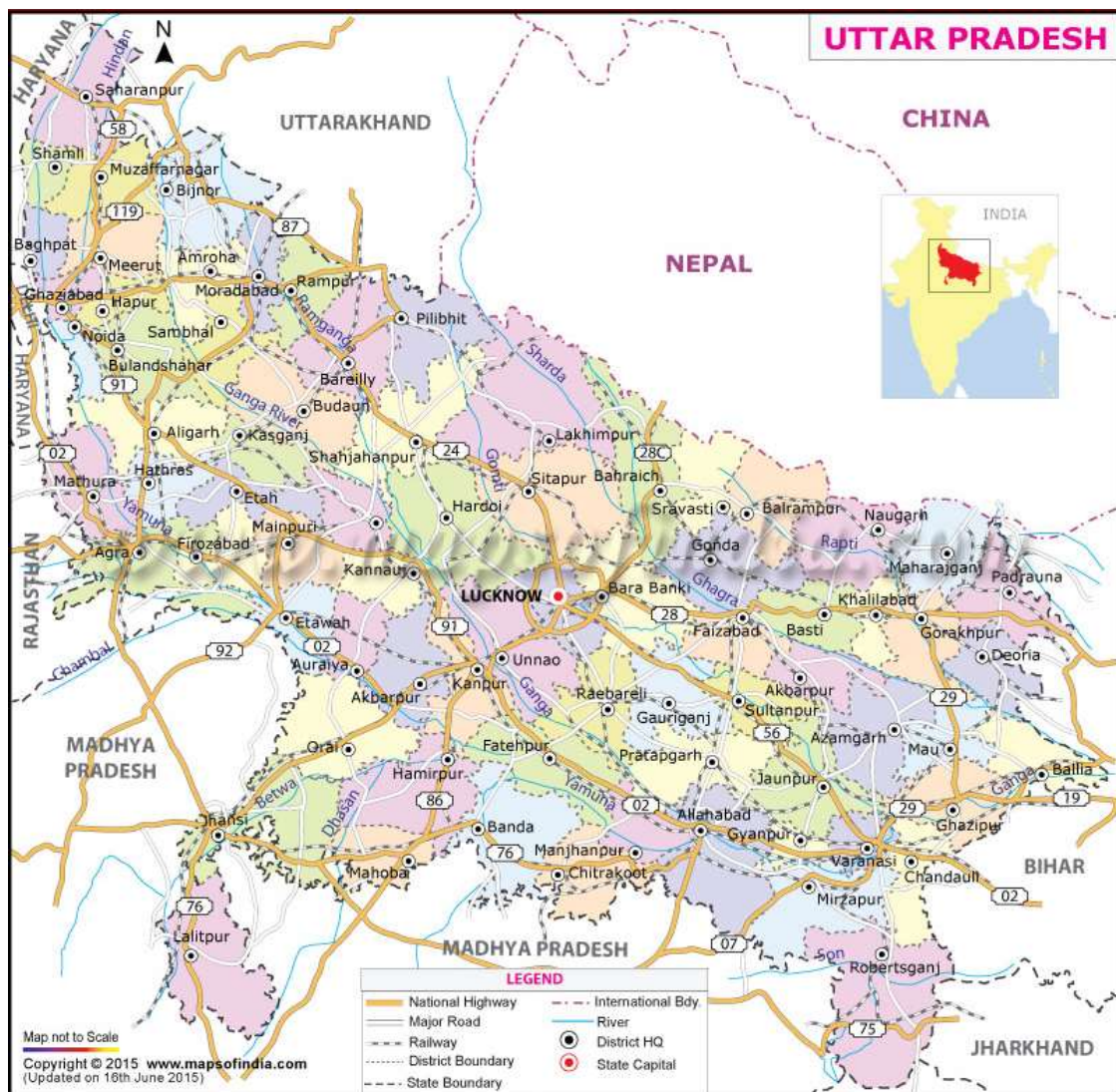

Source: Maps of India

Uttar Pradesh has been one of the most highly populated states in India for a long time now. According to the Census 2011 the state has a population of almost 200 million and with 20% (census 2011 compared to census 2001) one of the highest population growth rates in the country. The population density is therefore over 800 people per km² which is way above the national average of about 380. The sex ratio in 2011 is almost on a par with the national average and stands at about 900 women at 1,000 men¹.

The state has some of the most important educational institutions. The literacy rate in the state has gone up in recent years and reached a level of nearly 70% (2011) which is below the national average of 74%. It stands out that there is still a gap between men (77.3% literate) and women (57.2% literate).

Of the total population of Uttar Pradesh state, around 77.7% live in the villages of rural areas (22.3% in urban regions). In actual numbers total population of rural areas of Uttar Pradesh

¹ See for the whole Chapter 1: <http://www.census2011.co.in> (accessed 22 Oct 15)

state was 155,317,278. Average literacy rate in U.P. for rural areas was 65.5% whereas in urban regions 74.2% of the people can read and write.

A large part of the revenue of the state comes from the agriculture and the services sector. The chief crops are rice, wheat, and sugarcane. Since the late 1960s, with the introduction of high-yielding varieties of seed for wheat and rice, greater availability of fertilizers and increased use of irrigation, the state has become a major producer of food grains in the country. Many of its farmers however, still suffer from two major constraints: small landholdings and insufficient resources to invest in the technology required for improved production.

In terms of manufacturing, textiles and sugar refining are both long-standing industries in Uttar Pradesh which employ an important percentage of the state's total factory labor. Other resource-based industries in Uttar Pradesh produce vegetable oil, jute, and cement. The Indian government has established a number of large factories that manufacture heavy equipment, machinery, steel, aircraft, telephone and electronics equipment and fertilizers. The national government has funded an oil refinery at Mathura. Handicrafts constitute a significant portion of exports. Carpets from Bhadohi and Mirzapur, for example, are prized worldwide. Among other local specialties are the silks and brocades of Varanasi, ornamental brass ware from Moradabad, chikan embroidery from Lucknow, ebony work from Nagina, glassware from Firozabad, and carved woodwork from Saharanpur.²

The minerals found in Uttar Pradesh include limestone, glass sand and coal in considerable quantities. There also are small reserves of gypsum, magnesite, phosphorite, and bauxite.³

Transportation: A vast network of roads, including a number of national highways, and railways connects the state's cities and towns. For example the Yamuna Expressway, the rapid transit corridor between Delhi and Agra. It reduces the travel time between the capital and Agra by nearly four hours. The 165 km long Yamuna expressway is one of the longest access-controlled six-lane paved roads in India. It can be extended to 8 lanes in the future and would provide direct access to the forthcoming Yamuna Economic Zone and the international airport and aviation hub at Jewar, which are slated to be constructed along the Yamuna Expressway. Agra is already well connected to Kolkata, Mumbai, and Jaipur etc. by a network of national highways. This, along with the expressway, will provide high level connectivity to all these destinations from Delhi, especially when the proposed ring road around Agra town comes into being.⁴

The Agra Lucknow Expressway is an under construction 302 km controlled-access 6-lane expressway (expandable to 8 lanes). It is expected to be constructed until the end of 2016. The aim is to reduce traffic in already congested roads and highways. It would also ensure the development of adjoining areas as several townships are planned along the expressway. It would cut travel time between Agra and Lucknow almost in half. This expressway will be connected to Yamuna Expressway through the under-construction Agra Ring Road.⁵ In addition

² For further information, see <http://www.ibef.org/download/Uttar-Pradesh-August-2015.pdf> (accessed 27 Jan 16)

³ See for the whole Chapter 1.1: <http://www.britannica.com/place/Uttar-Pradesh>

⁴ See http://articles.economictimes.indiatimes.com/2012-04-07/news/31304852_1_yamuna-expressway-noida-greater-noida-expressway-jewar

⁵ See https://en.wikipedia.org/wiki/Agra_Lucknow_Expressway

to that a new 382 km six-lane expressway highway between Lucknow and Ballia is talked about.⁶

Concerning rail transport, the Eastern Dedicated Freight Corridor Project was established to provide additional capacity, improve service quality and higher freight throughput on the 343 km Khurja-Kanpur section of the Eastern rail corridor.⁷

Besides the Ganges River, the inland waterways Yamuna and Ghaghara also play a substantial part in the state's transportation system. As in 2007/2008, inland waterways with a total length of 425 km were navigable (18.1% of the total length of U.P.'s rivers, canals and lakes).⁸

In 2007/2008 a total volume of more than 127 MMT of inter-regional freight traffic originated in U.P. (8.3% of the national total), with about 16 MMT having the state as a terminus. Of the total volume, a share of 40.9% was transported by rail, while 59.1% was apportioned to road traffic.⁹

2.1.2 Bihar

Located in the eastern region of India, Bihar is spread over 94,163 km². In November 2000 the state of Jharkhand was created from Bihar's southern provinces and thereby decreased Bihar's size remarkably. Bihar is naturally divided by the Ganges River into two regions: North Bihar and South Bihar. It shares borders with Nepal and the states Jharkhand, Uttar Pradesh and West Bengal (W.B.). The GDP growth at constant prices over the last ten years was very volatile and results in an average of 9.5%. The city Patna is Bihar's capital.

⁶ See <http://timesofindia.indiatimes.com/city/lucknow/Plan-for-expressway-from-Lucknow-to-Ballia-6-lane-highway-to-pass-Azamgarh-reach-Bihar-border/articleshow/46137244.cms>

⁷ See <http://www.worldbank.org/projects/P114338/eastern-dedicated-freight-corridor?lang=en>

⁸ See Government of India, Statistics of Inland Water Transport 2013-14 (accessed 27 Jan 16)

⁹ See http://planningcommission.nic.in/reports/genrep/trans/Chapter_3.pdf (accessed 27 Jan 16)

Figure 2: Map of Bihar



Source: Maps of India

As per details from Census 2011, Bihar has a population of 104.1 million, an increase from a little over 25% compared to the 2001 Census. In relation with the states size the population density is 1,106 people per km² and is with that the highest in the country. The sex ratio amounts 918 (census 2011) which is represented by 54.3 million male and 49.8 million female citizens. The population of Bihar forms 8.6 percent of India in 2011, but it belongs also to the poorest states of India.

Literacy rate in Bihar has seen an upward trend and has reached 61.8% (2011 census). Of that male literacy stands at 71.2% while only every second woman can read and write. In 2001 total literacy rate in Bihar only stood at 47.0% which is about one third less than in 2011. But compared to the country average Bihar still lags behind in literacy.

Like in other states major parts of the population live in rural areas (88.7%). Only little above 10% is living in urban regions where the literacy rate is noticeably higher than in rural areas.

Agriculture is the backbone of Bihar's economy. The percentage of population employed in agriculture production system in Bihar is estimated at 81%, which is much higher than the national average. Those 81% generate nearly 42% of the State Domestic Product. The principal agricultural crops are rice, paddy, wheat, jute, maize and oil seeds. Cauliflower, cabbage, tomato, radish, carrot, beat, sugarcane, potato and barley are also grown in the state.¹⁰

Manufacturing: Bihar has been slow to develop industry. Among the agriculturally based industries are sugar refining, tobacco processing, silk production, and jute milling. Traditional cottage industries are popular in Bihar. In particular they include sericulture (raising of

¹⁰ See <http://krishi.bih.nic.in/>

silkworms and raw silk production), lac (resin used to produce shellac) and glasswork, handloom products, brassware, and pottery.

Bihar's mineral wealth was virtually depleted in 2000 when the mineral-rich Chota Nagpur plateau became part of Jharkhand. But there are still little resources left like bauxite, dolomite, glass sand, cement mortar, and other minerals like Mica and Salt.

Transportation: Several national highways pass through the state, including the Grand Trunk Road, which is one of India's oldest roadways. However, large parts of the highways are in bad shape. To counter this problem, the state government has set out an agenda to improve road infrastructure in Bihar over the next one year in which the Road Construction department (RCD) will undertake repair of 1,855 km roads and 124 bridges.¹¹ If it comes through, the expressway between Lucknow and Ballia would touch Ballia on the U.P.-Bihar border.

The rail line between Kolkata (Calcutta) and Delhi, which crosses Bihar, opened in 1864. Because of the dense population the railways carry a heavy load of traffic. But there are new rail way projects in sight. The Indian Railway projects in Bihar, including the sick Bharat Wagon Engineering Limited (BWEL), are rolling on the right track and a couple of them have already started operating according to a Railway Board member.¹² The implementation of the long-stalled Madhepura electric loco plant and the Marhaura diesel loco plant has been accelerated with the projects been chosen for execution using foreign direct investment (FDI).¹³

The total length of Bihar's rivers, canals and lakes amounts to 2,229 km. In 2013/2014, 62.4% of these waterways (1,391 km) were navigable and a total cargo volume of about 2,400 tons was carried.¹⁴

In 2007/2008, a total volume of 40 MMT of inter-regional freight traffic originated in Bihar (1.7% of the national total), with 5.8 MMT tons having the state as a terminus. Of the total volume, a share of 27.7% was transported by rail while 72.3% was apportioned to road traffic.¹⁵

2.1.3 Jharkhand

Jharkhand is a land locked state also located in the eastern region of India. Its total area adds up to 79,716 km². Among other, the state shares borders with Bihar, Uttar Pradesh and West Bengal. The state's east peak connects to the Ganges River and on Jharkhand's west corner the border aligns with the Son River which is the second largest of the Ganges' southern tributaries after the Yamuna River. Jharkhand's GDP growth at constant prices has seen its ups and downs over the last decade. It reached from -3.2% in 2005/06 to 20.5% in 2007/08. The average growth amounts to almost 7% (6.98%). The capital of Jharkhand is Ranchi.

¹¹ See http://articles.economictimes.indiatimes.com/2014-10-17/news/55148431_1_rcd-bridges-gandhi-setu

¹² See <http://economictimes.indiatimes.com/industry/transportation/railways/railway-projects-in-bihar-rolling-on-track/articleshow/47605480.cms>

¹³ See <http://economictimes.indiatimes.com/industry/transportation/railways/rail-projects-in-bihar-put-on-fast-track-with-assembly-elections-around-the-corner/articleshow/47593507.cms>

¹⁴ See Government of India, Statistics of Inland Water Transport 2013-14

¹⁵ See http://planningcommission.nic.in/reports/genrep/trans/Chapter_3.pdf (accessed 27 Jan 16)

Figure 3: Map of Jharkhand



Source: Maps of India

As per details from Census 2011, Jharkhand had a population of 33 million. Compared to 2001, the total population growth in this decade was 22.4%. The population density of Jharkhand amounts to 414 per km² which is still above nation average (382). The sex ratio in 2011 was 948 women per 1,000 men.

Literacy climbed up 24% in the last decade to a level of 66.4% (population Census 2011) and had already surpassed 50% in 2001. As seen in Bihar and Uttar Pradesh male literacy stands at 76.8% higher than female literacy with only 55.4%.

Of the total population of Jharkhand more than two thirds (75.9%) live in rural areas where the literacy rate for women is still below 50% (46.6%, males 72.9%). Average literacy rate in Jharkhand for rural areas was 61.1% and female sex ratio per 1,000 males was 961. In urban regions the literacy rate is higher (82.3% men, 67.8% women), but the sex ratio is by fifty women lower.

The agriculture sector is of great significance for Bihar. The state's agricultural-development programs have especially emphasized the raising of livestock for meat, dairy products, and wool. Major crops cultivated in the state are maize, rice and wheat.¹⁶

¹⁶ See <http://www.icar.org.in/files/state-specific/chapter/62.htm> (accessed 22 Oct 15)

The majority of the manufacturing workforce of Jharkhand works in the traditional cottage industry. They engage in sericulture, lac and glasswork, handloom products, brassware, stone carvings, cane and bamboo products, various woodworks, and pottery. Most of the remaining workforce is employed in metal- and agriculture-based industries. Among the principal agricultural industries are sugar refining, tobacco processing, and jute milling.¹⁷

Minerals: The Chota Nagpur plateau is the richest mineral belt in India, and it is responsible for a significant share (by value) of the country's mineral yield. Jharkhand produces almost the entire national output of copper, kyanite, pyrite, and phosphate, as well as much of the output of bauxite, mica, kaolin and other clays, and iron ore. Most of these minerals are mined in the districts of East and West Singhbhum. Coal, however, accounts for the bulk of Jharkhand's mineral production. The principal coalfields, all in the Damodar River valley in eastern Jharkhand, supply most of the coking coal of India. The State of Jharkhand had the maximum share (26.8%) in the overall reserves of coal in the country as on 31 March 2014 followed by the State of Odisha (24.9%).¹⁸

Transportation: A number of national highways pass through the state, including the Grand Trunk Road (one of the oldest roads in India). Although the road network has expanded over the last years, not even half of the villages can be reached by roads which can withstand the rain. For further improvement the state cabinet engaged a leading finance company as transaction manager for an expressway linking Ranchi, Jamshedpur and Dhanbad. *Infrastructure Development Finance Company* (IDFC) has been made the transaction manager to construct an expressway that aims to link Dhanbad with Ranchi and Jamshedpur (Golden Triangle) in public-private-partnership (PPP) mode.¹⁹ Another project concerning Physical Infrastructure and especially Transportation is the Hazaribagh Ranchi Expressway Limited. This project includes the development of four lanes with an aggregate length of approximately 319 lane-km connecting Hazaribagh to Ranchi in the State of Jharkhand.²⁰

The Kolkata-Delhi rail line, which opened in 1864, crosses Jharkhand. Extensive goods handling facilities are located along the rails at Ranchi, Bokaro, Dhanbad, and Jamshedpur. In addition, ore-loading facilities are available at Lohardaga, in west-central Jharkhand, and at all the coal mines.²¹ All in all are in Jharkhand 980.32 route km including loops and slings.²²

In 2007/2008, a total volume of 134.4 MMT tons of inter-regional freight traffic originated in Jharkhand (5.6% of the national total), with 75.4 MMT tons having the state as a terminus. Of the total volume, a share of 81.7% was transported by rail while 18.3% was apportioned to road traffic.²³

¹⁷ For further information, see <http://www.ibef.org/download/Jharkhand-August-2015.pdf> (accessed 27 Jan 16)

¹⁸ See http://mospi.nic.in/Mospi_New/upload/Energy_stats_2015_26mar15.pdf?status=1&menu_id=243 (accessed 22 Oct 15)

¹⁹ See http://www.telegraphindia.com/1150520/jsp/jharkhand/story_20929.jsp#.VfZjuUaAC71 (accessed 22 Oct 15)

²⁰ See <http://www.ilfsindia.com/projects.aspx?prid=9&catid=1&slnk=156&cid=5>

²¹ See <http://www.britannica.com/place/Jharkhand>

²² See <http://www.ser.indianrailways.gov.in/uploads/files/1427374984205-Part%20data%20SER.pdf>

²³ See http://planningcommission.nic.in/reports/genrep/trans/Chapter_3.pdf (accessed 27 Jan 16).

2.1.4 West Bengal

West Bengal (W.B.) is a state in eastern India and spreads over 88,750 km². The state borders with Bangladesh on the east side, Bhutan on the north side, the states Bihar and Jharkhand in the West and connects to the Indian Ocean on its south End. The Ganges flows through the middle of the state and passes the cities Rajshahi and Farakka. The capital GDP growth at constant prices in W.B. averaged 6.6% in the last 10 years. The state's capital is Kolkata.

Figure 4: Map of West Bengal



Source: Maps of India

According to the West Bengal Census 2011, it is the fourth most populated state in India. The total population counts 91.3 million, which is almost 14% more than what was counted in 2001. The population density of W.B. is 1,028 per km² and therefore exceeded the one thousand

mark like Bihar did. The total population consists of 46.9 million men and 44.4 million women, which is reflected in a sex ratio of 918.

The state is home to a number of renowned educational Institutions and higher learning Centers. There are 18 universities in the state along with sizeable research institutes.²⁴ Total literacy rate in West Bengal is 77.1%.

Out of total population of West Bengal, 31.9% people live in urban regions, which is more than in the other three discussed states. Sex Ratio in urban regions of West Bengal was 944 females per 1,000 males. Average literacy rate was 84.8% (88.4% male literacy 76.0% female as of 2011 Census). Around 68% live in villages of rural areas. The literacy rate for males and female stood at 78.4% and 62.0%. Average literacy rate in rural areas was 72.1% and the sex ratio slightly more balanced (953).

Agriculture is the mainstay of the state's economy and accounts for the largest share of labor force. W.B. is, with over 15 tons, the largest rice producer in India. Besides rice, potatoes are the principle crops of West Bengal, followed by Jute, Sugarcane, Wheat and Maize. The state supplies nearly 100% of the potato requirement and 66% of the jute requirements of India. Tea is another important cash crop and especially Darjeeling is famous for tea plantation.

Manufacturing: State industries are mostly localized in the Kolkata region and the mineral-rich western highlands as well as Haldia port region. There are up to 10,000 registered factories in the state. Kolkata is noted as one of the major center for industries including the jute industry. There are numerous steel plants in the state. The center has established a number of industries in the areas of tea, sugar, chemicals and fertilizers. Natural resources like tea and jute has made West Bengal a major center for the jute and tea industries.²⁵

Among the minerals which can be found in West Bengal are coal, cement, iron, lignite, limestone and fireclay.²⁶

Transportation: West Bengal offers excellent connectivity to the rest of India in terms of railways, roadways, ports and airports. As of 2011, West Bengal has a total road length of 92,023 km, with a road density of 1.04 km per km². Of this, national highways constitute 2,578 km and state highways 2,393 km. The Golden Quadrilateral (GQ) project undertaken by the National Highway Authority of India (NHAI) passes through major districts in North part of West Bengal. As of July 2011, four-laning of Dhankuni-Kolaghat (54.4 km) KologhatKharagpur (60.5 km) and Kharagpur-Laxmanath (65.8 km) sections had been completed. A number of road development projects have been taken up under public private partnerships, for example the Kolkata-Durgapur expressway, Palsit-Dankuni road project and PanagarhPalsit road project.

The railway route length in the state is around 4,481 km. The state has namely three railway stations: Howrah, Sealdah and Calcutta for accessing the city of Kolkata and New Jalpaiguri.

²⁴ See for the whole Chapter 1.4: http://www.ibef.org/download/West_Bengal_271211.pdf

²⁵ See http://www.wbdc.com/about_wb/industrial_infrastructure.htm

²⁶ See <http://www.mapsofindia.com/maps/westbengal/westbengalminerals.htm>

Once Kolkata is reached, all tourist destinations in West Bengal are very well connected from there.²⁷

The total length of West Bengal's waterways (rivers, canals and lakes) amounts to 4,741 km of which 96.9% (4,593 km) were navigable in 2013/2014. During this time span, a cargo volume of about 11.5 MMT was carried by IWT.²⁸

In 2007/2008, a total volume of 83.2 MMT tons of inter-regional freight traffic originated in W.B. (3.5% of the national total), with 126.2 MMT having the state as a terminus. Of the total volume, a share of 63.6% was transported by rail while 31.7% was apportioned to road traffic.²⁹

2.1.5 Madhya Pradesh

Though not directly located alongside the NW-1, the state of Madhya Pradesh (M.P.) can nevertheless be considered as potential hinterland of the inland waterway corridor. With a size of around 308,000 km² (about 9.4% of India's total area), M.P. is India's second largest state and occupies a geographically central position in the country. The landlocked state shares borders with U.P., Rajasthan, Gujarat, Maharashtra and Chhattisgarh. The state capital is the city of Bhopal. Though quite volatile in the past, in recent years M.P. showed a yearover-year GDP growth at constant prices in the region of 10%.³⁰

According to the 2011 census, M.P. has a population of 72.6 million which constitutes an increase of just over 20% compared to the 2001 census. The population density ranges in the region of 236 people per km² which is below the national average. The sex ratio stands at 931 women/1,000 men.

The literacy rate in M.P. accounts to 69.3% (2011 census) which is slightly below the national average. Furthermore the state is characterized by a rather large gender gap in the educational level: while the statewide literacy rate for men is at 78.7%, the corresponding value for women accounts to just 59.2%.

With just 27.6% of its population living in urban areas, M.P.'s level of urbanization is below the national average of 31.2%. In line with expectations, the literacy rate is higher among people living in urban areas than among those living in rural areas.³¹

As a vast majority of 72.4% of M.P.'s population lives in rural areas, the agricultural sector is central to the state's economy. M.P. is the largest producer of pulses, oil seeds and soybean in India and a major growing area for garlic and coriander. Various crops such as wheat, rice, maize, cotton and mustard are cultivated. M.P.'s total food grain production in 2013/2014 accounted to around 27.6 MMT.

²⁷ See <http://www.westbengaltourism.gov.in/web/guest/rail>

²⁸ See Government of India, Statistics of Inland Water Transport 2013-14

²⁹ See http://planningcommission.nic.in/reports/genrep/trans/Chapter_3.pdf (accessed 22 Oct 15)

³⁰ See http://planningcommission.nic.in/data/datatable/data_2312/DatabookDec2014%2059.pdf (accessed 22 Oct 15)

³¹ See http://www.dataforall.org/dashboard/censusinfoindia_pca/ (accessed 27 Jan 16)

Figure 5: Map of Madhya Pradesh

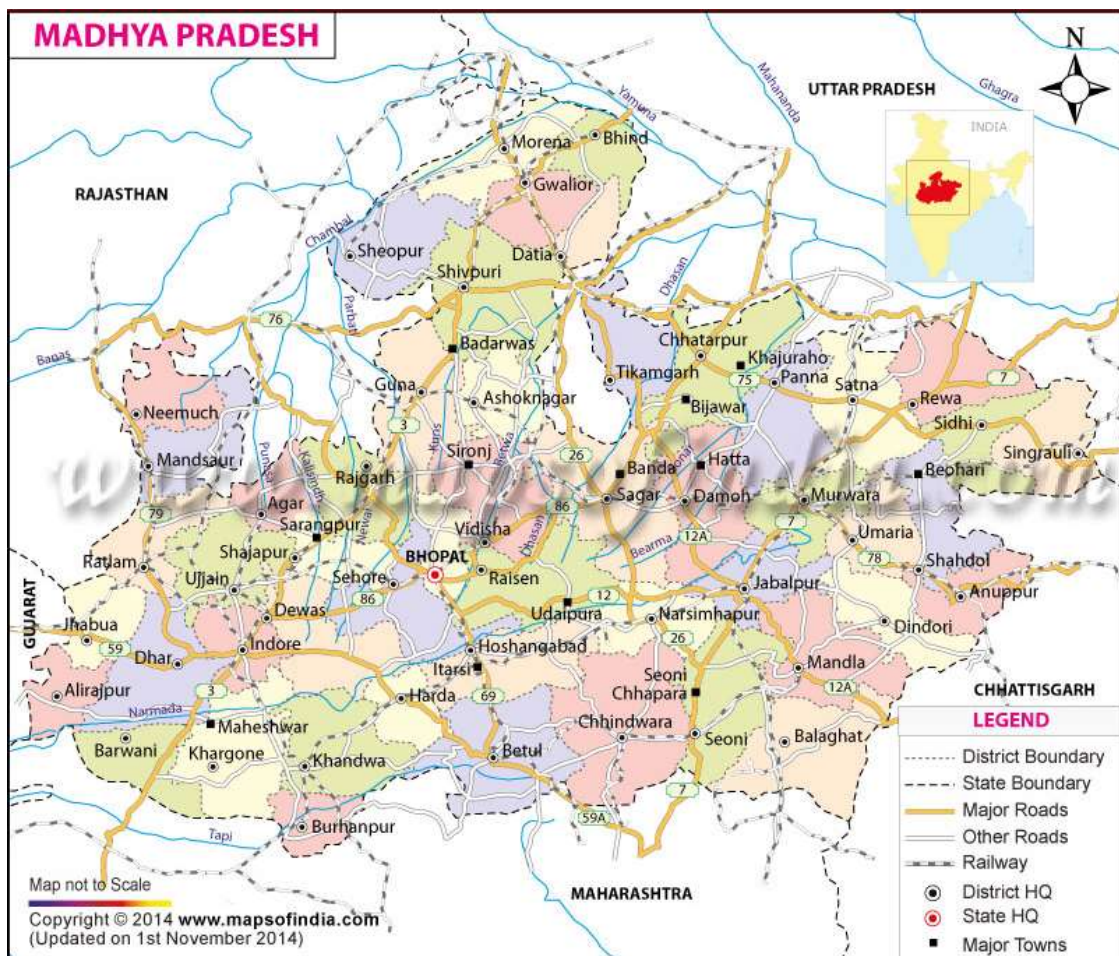

Source: Maps of India

Regarding its industrial structure, Madhya Pradesh has attracted an increasing number of high-tech industries, including companies from the electronics, pharmaceutical, automobile and information technology sectors. The city of Indore is one of M.P.'s commercial centers and home to a special economic zone. Also within the same region, a large number of automobile industries have located themselves at the city of Pithampur. M.P. is also well known for traditional manufacturing of handicrafts and handloom cloths. The cities of Chanderi and Maheshwar are centers for these industries.

M.P. has one of the largest reserves of minerals in India. Among the variety of different minerals produced are dolomite, diamond, limestone, bauxite, copper and coal.

Transportation: Due to its central location, M.P. is well connected to India's major cities, consumer markets and the west coast ports. 19 national highways with a total length of 5,185 km stretch throughout the state. These are complemented by 10,859 km of state highways and 19,574 km of major district roads. Public-Private-Partnerships are used as a mean in the development of the road network. As of March 2015, the state had a total of 185 PPP projects in the road sector.

Due to its central location, M.P. has a fairly well-developed railway network. The state capital Bhopal is home to one of the country's main railway junctions and railway lines with a total length of around 4,954 km are passing through the state. In particular, the railway network is

of great importance to the states mineral and agro-based businesses as it helps these industries by transporting bauxite, dolomite and limestone as well as fertilizer and de-oiled cake.³²

In 2007/2008 a total volume of 147.5 MMT of inter-regional freight traffic originated in M.P. (6.2% of the national total), with 127.7 MMT having the state as a terminus. Of the total volume, a share of 34.7% was transported by rail while 65.3% was apportioned to road traffic.³³

2.1.6 Summary

As stated in the previous chapters, in all four states along the NW-1 agriculture plays an important role. Huge amounts of crops have to be distributed throughout the whole country either to serve the domestic demand or have to be moved to harbors for the purpose of export. An easy way of transportation would be to use an inland waterway craft to ship the crops as dry bulk goods to their destination. The upper part of the Ganges River is dividing an agricultural region (north) from a manufacturing one (south). Across the river, not only crops have to be transported southwards, but also fertilizer which is needed to grow the crops has to be brought northwards. This is a good way to use inland waterway crafts on the NW-1 and, as there do not exist sufficient bridges across the river, ro-ro crossings would be required at highly frequented places.

Road Network

The road transport infrastructure in India has expanded manifold during more than six decades after independence, both in terms of spread (total road length and road density) and capacity (number of registered vehicles on road and the volume of passenger and freight traffic handled). Indian road network consists of National Highways, Expressways, state highways, major district roads, village roads etc.

Table 1: State-wise road network indicators

States	Total Road Length (km)	Surfaced Road (%)	Road Density (per 1000 km ²)	Road Density (per 1000 population)	Registered motor vehicles (per '000 heads)
Uttar Pradesh	403,102	7.26	1,673.12	1.97	31.44
Bihar	138,517	47.18	1,471.03	1.40	98.98
Jharkhand	26,277	71.68	329.64	0.82	75.62
West Bengal	315,404	41.82	3,553.77	3.49	42.75
Madhya Pradesh	201,261	63.57	652.93	2.74	71.33
Total India	3,965,394	63.41	1,206.29	3.28	132.02

Source: Infrastructure Statistics -2014 (Third Issue, Vol. I), Central Statistics Office, New Delhi, p.40

Whereas national highways and state highways are well maintained, with more than 90% being surfaced; urban and rural roads are not in good condition. Only 48% of rural roads are surfaced. Comparison of rural and urban road density indicates significant increase in urban road network whereas that in rural area has remained almost same during last five years. Rural areas are lagging behind in accessibility to roads whereas urban roads are more congested. Important hubs for transportation – particularly between the heavily populated and

³² See <http://www.ibef.org/download/Madhya-Pradesh-August-2015.pdf> (accessed 27 Jan 16)

³³ See http://planningcommission.nic.in/reports/genrep/trans/Chapter_3.pdf (accessed 27 Jan 16)

industrialized northwest and the rather agricultural and mineral-endowed southeast regions, are Kanpur, Allahabad and Varanasi in Uttar Pradesh, Patna and Aurangabad in Bihar state, Dhanbad and Ranchi in Jharkhand, and Purulia, Asansol and Durgapur in West Bengal. Of these hubs, the cities of Allahabad, Varanasi and Patna are located on the NW-1 and thus provide great opportunities for multi-modal cargo transportation.

Rail Network

Heavy industries are linked by rail transportation. However, the total route length of railway network has increased only marginally during the last decade. In a recent development, rail travel has shown significant improvement in quality in terms of positive growth in electrification of track and gauge conversion from narrow gauge, meter gauge to broad gauge. The below table indicates that, while the railway network has a density above the Indian average for the three states Bihar, U.P. and W.B., it is comparatively low in Jharkhand.

Table2: State-wise rail density (area and population)

States	Route Kilometrage (numbers)	Rail Density (per 1000 km ²)	Rail Density (per 1000 population)	Share of broad in total gauge (%)
Uttar Pradesh	344.91	1	0.00	84
Bihar	3,598.09	38	0.04	100
Jharkhand	2,040.04	26	0.06	82
West Bengal	4,000.38	45	0.04	94
Madhya Pradesh	4,954.32	16	0.07	86
Total India	64,600.47	20	0.05	87

Source: Infrastructure Statistics -2014 (Third Issue, Vol. I), Central Statistics Office, New Delhi, p.45

However, passenger fares have been increased only marginally, despite steep rises in fuel and other costs. Freight rates have been increased frequently to subsidize passenger services. In the past, railway development had lacked commercial orientation and little had been invested for the growth of freight traffic, despite freight being the mainstay of earnings. As a result, during the last decades the railways had steadily lost share in freight movement to road transport. Its share has dropped to 30% from a peak of 89% over 60 years ago. Studies suggest that the rail's share of freight transportation will fall to 25% by 2020.³⁴

Inland-Waterway Network

With 4,741 km, West Bengal is endowed with the second longest waterway net of the entire Indian country. The ratio of the navigable length to the total length of the river/canal best reflects the potential for IWT. This ratio is about 97% in the State of West Bengal, and still more than 62% in Bihar. Compared with navigable length of their waterways, infrastructure endowment in these two states is relatively low. In contrast, in Uttar Pradesh the ratio of the navigable length to the total length of its waterways is as low as 18%.

³⁴ See <http://www.platts.com/news-feature/2015/coal/india-coal-transport/railway-funding> (accessed 11 Feb 16)

Table 3: State-wise length of rivers, canals and lakes, and infrastructure endowment

States	Total Length (km)	Navigable Length (km)	Berths (numbers)	Infrastructure Endowment (km/berth)
Uttar Pradesh	6,444	425	- 3 floating	142
Bihar	3,763	1,391	1 fixed, 5 floating	232
Jharkhand	81	81	- 2 floating	41
West Bengal	4,741	4,593	3 fixed, 10 floating	353

Source: Statistics of Inland Water Transport 2013-14, Ministry of Road Transport & Highways, New Delhi, pp. 1-7

As a result, IWT in India takes a share of 3% of national cargo and passenger transport output, whereas this share lies in China at 47%, in Japan at 41%, in Korea at 44% per cent and in European countries at over 40%.

Logistics Network

There are three agencies in the public sector which are engaged in building large scale storage/ warehousing capacity- Food Corporation of India (FCI), Central Warehousing Corporation (CWC) and 17 State Warehousing Corporations (SWCs). In addition to storage of food grains, storage also includes industrial warehousing, custom-bounded warehouses, container freight stations, inland clearance depots and air cargo complexes.

Table 4: State-wise food grain storages, cold storages, warehouses and container depots

States	Food grain Storages (in MT)	Cold Storages (in number)	Warehouses (in number)	Container Depots (in number)
Uttar Pradesh	680,503		48	7
Bihar	87,675		16	
Jharkhand	19,300		3	
West Bengal	164,160	1	37	2
Madhya Pradesh	310,839		26	
Total India	5,264,854	4	467	37

Source: Infrastructure Statistics -2014 (Third Issue, Vol. I), Central Statistics Office, New Delhi, p.45

Another commodity of dry bulk freight and of great importance besides agricultural goods is mined ores. The states have rich mineral resources and extraction sites. Therefore inland waterway crafts play an important way of transportation again.

Sensitivity Analysis of main Drivers

The population is growing constantly. As consequence thereof the domestic demand for food and goods will rise. In addition to that there are more people who need transportation and will be affluent enough to afford it. On the other hand, diesel prices will, in the medium term, rise again thus giving motivation for cargo owners to shift transport onto affordable modes. The plans to improve street and rail infrastructure have not all been finished and even if there are better and more roads, there are more people and cars as well, which still leaves limited capacities for commodity transportation. Cargo-carrying capacities on both road and rail have reached or exceeded their limits. Before the year 2020, the Eastern Dedicated Freight Corridor (EDFC) will not be completed to unplug this bottleneck (see Chapter 2.2.4). Even then, the EDFC will connect Kolkata, Varanasi and Allahabad with Delhi, but will pass in a large distance the other cargo-generating centers in vicinity of the NW-1.

Therefore it is obvious that, to manage the amounts of goods and cargo, an inland-waterway transportation system is very much needed. However, in the long term, operations on the NW-

1 face a challenge: One of the primary sources of fresh water supply to the Ganges River, the 30.2 km long Gangotri glacier, has been found to have retreated by more than 1.5 km in the last 70 years. During the past decade, this process has accelerated: Since the year 2000, annual snowfall decreased by 37 cm, while maximum and minimum temperatures increased by 0.9⁰C and 0.05⁰ C respectively.³⁵ The GoI therefore needs to develop appropriate mitigation measures against the NW-1 losing too much of its primary ingredient: water.

2.2 Indian Government IWT policies and subsidies

2.2.1 Background

The *National Waterways Bill, 2015* was introduced in Lok Sabha on 05 May 2015 by the Minister of Road Transport and Highways and Shipping.

The Bill identifies additional 101 waterways as national waterways. The Schedule of the Bill also specifies the extent of development to be undertaken on each waterway.

The *Statement of Objects and Reasons of the Bill* states that while inland waterways are recognized as a fuel efficient, cost effective and environment friendly mode of transport, it has received lesser investment as compared to roads and railways. Since inland waterways are lagging behind other modes of transport, the central government has evolved a policy for integrated development of inland waterways.

Promotion of waterways is a priority for this government as it is a cheaper mode of transportation as compared to roads and railways.

India is estimated to have nearly 14,500 km of navigable inland waterways, even though the exploitation of sector has remained neglected as most waterways in the country require constant dredging on account of heavy silting and draft is available only seasonally. Besides, not many entrepreneurs are willing to invest in inland vessels, which have resulted in underutilization of whatever infrastructure is created, thereby spelling trouble for the development of the sector.

Other, technical constraints are hindering the development of IWT such as:

- Diversion of water for irrigation, industrial and other needs reducing the flows in the rivers resulting in the reduction of depth and shoal formation.
- Excessive silt loads from erosion of uplands due to bad catchment management and increased deforestation.
- Inadequate river conservancy measures, resulting in gradual deterioration of waterways.
- Non availability of adequate navigational aids resulting in unsafe passage and high travel time.
- Inadequate vertical and horizontal clearances for plying vessels of economic size in many traditional waterway routes.

³⁵ Snow and Avalanche Study Establishment, Defense Research and Development Organisation (DRDO), Chandigarh / India, December 2015

- Lack of adequate terminal facilities at the loading and unloading points being non-existent and where existent.
- The above constraints are well known by the appropriate ministries. The NDA government has emphasized that developing the IWT sector is a priority. A Bill regarding the development of the IWT sector has already been moved in Parliament. Conferences to integrate the IWT stakeholders are taken place in Delhi, the most actual one is planned for 27 October 2015.
- The Ministry says that they would ask the state governments to have a stake of 26 per cent in development of the waterways in the new Bill that would be placed in Parliament the Centre would bear the rest of the cost. The Bill was tabled in the Lok Shaba during the Budget session and referred to the Parliamentary Standing Committee on Transport.
- Slow progress has been a constant problem in this Sector. Even after two decades, the waterway development remains incomplete. Targets in terms of fairway capacity, cargo, vessels and IWT operations have only declined, one of the former members (Technical), IWAI stated.
- It is against this background that the government has now decided to launch projects for setting up dry and satellite ports, besides converting river ways into waterways.

The development of IWT is seen as a prerequisite to remain globally competitive. In the national plan for logistics and transport the modal split of water transport (IWW and coastal shipping) is expected to increase from 13% in 2005 to 29% in 2025. The Working Group Report on Shipping and Inland Transport for the Eighth Five-Year Plan 2007-2012 also states that the 2024-25 cargo volume in inland waterways is expected to be 0.10 MMT which roughly works out to be 26.2% from the 2005 figure. Also, ET reports may be by Feb 2015 that it would grow by 29%.

However, concordantly the benefits for an increase in inland waterway transport can be seen in the improved land-use, more efficient usage of surface modes, greater energy efficiency (through more efficient vessel utilization) and pollution prevention.

While the IWAI has been actively working on dredging, surveys, channel marking, river conservancy works, construction of terminals and procurement of hardware like dredgers, demonstration barges, survey launches since 1986, neither the number of cargo vessels nor the quantum of cargo movement has shown any improvement, except some cases of coal and fertilizer movement on the Haldia-Farakka stretch on the Ganges River as per the following picture.

Figure 6: Progress in IWT development
on national waterways



Source: Indian Express, 19 August 2015

Delays / turnaround time and water depth is another big problem in Inland waterways. Sustainable depth in terms of river morphology and environment should also be the basis for classification to avoid conflicts and delays. The problem is that most of the waterways included in the list of 101 new waterways are fresh water rivers, which even dry up completely during post monsoon period. The diversion of water for navigation should not be at the cost of other priority use such as drinking and irrigation. According to some, unless a very detailed study is done on the balanced use of water, the 101 NW proposals is bound to face opposition from many state governments.

Some of the important issues to be debated before the National Waterway Bill, 2015, include the point whether the declaration of a national waterway is a legislative function of Parliament.

There are question marks over whether the state governments been taken into confidence on the proposal. Experts point to the need for setting up of Statutory Autonomous Boards with representatives of central and state governments and technical experts for each national waterway.

Without some of these niggling issues being sorted out, the government's new waterway thrust could well end up with the same problems facing the handful of waterways operational currently stranded amid heavy silt and sheer a lack of impetus.

With a view to providing an impetus for development for inland water transport mode, the Government of India had approved an Inland Water Transport Policy which includes fiscal concessions, and policy guidelines for rapid development of the mode and to encourage

private sector participation in development of infrastructure and ownership and operation of inland vessels.

In order to reduce the capital burden on the IWT operators, and to enhance their profitability, an inland vessel building subsidy scheme existed some years ago under which 30 per cent cost of an inland vessel is subsidized by the Central Government. This is applicable to both cargo and passenger inland vessels meant for operation in National Waterways, Sunderbans waterways and Indo-Bangladesh Protocol Route. However, the scheme has ended 31st 2007. Efforts are being made to extend this scheme for some more years.

For exploring possibility of joint ventures and BOT projects in IWT sector, interactions were held with many interested firms and thereafter, some priority projects having potential of Joint Venture projects were short-listed. For some of these projects, bids were invited by IWAI. This initiative of IWAI has succeeded in attracting some private player to IWT sector and four Memorandum of Understanding (MOU)'s have been signed between IWAI and respective successful bidders for setting up and management of jetties at various locations.

2.2.2 Scheme for Incentivizing Modal Shift of Cargo (SIMSC)

Following the acknowledgement and national economic relevance of Inland Waterway Transport, the Ministry of Transport has currently started one initiative on supporting the IWT by a specific co-financing program.

In a bid to decongest the country's road and railway networks and encourage coastal and inland waterways transportation, the Ministry of Shipping is initiating a Scheme for Incentivizing Modal Shift of Cargo (SIMSC) under which certain identified commodities, containerized cargo and automobiles when moved through coastal shipping in various forms will be monetarily incentivized. The commodities identified for incentivizing under the scheme have high potential for transportation through coastal and inland waterways but are currently reliant on other modes of transportation.

The Scheme for Incentivizing Modal Shift of Cargo, in addition to promoting coastal shipping and inland waterway transportation as a viable alternative to road and railway transportation, aims to minimize the environmental impacts as well as the social costs of congestion in road and railway networks. It was planned to be initially implemented during the period 01 April 2015 to 31 March 2017 of the 12th Five-Year Plan. A provision of Rs 2.96 billion has been made for implementation of the scheme during the plan period. The scheme will be reviewed at the end of the plan period for continuation in the 13th Five-Year Plan.

The SIMSC could be availed by shippers who transport the identified categories of cargo through coastal shipping or inland waterways or both using Indian flag vessels, river sea vessels or barges. The coastal shipping or inland waterway routes through which the eligible cargo is transported should involve at least one major port, designated non-major port or Inland Waterways Authority of India terminal/jetty at the point of loading or discharge. The shipper is the person who has ownership of the cargo and may be the consignor or the consignee. The categories of cargo eligible for incentives under the scheme include bulk or break-bulk cargo commodities such as fertilizers, food grains, marbles, tiles, sugar, edible salt and over-dimensional cargo, any type of commodity carried in containers in full container load and automobiles in the form of two wheelers, three wheelers and four wheelers (HMV & LMV). In

case of trucks or trawlers carrying automobiles, containers (any commodity) or identified bulk or break-bulk cargo that are transported on Ro-Ro vessels, the incentives will be provided only for the respective commodities.

The Ministry of Shipping in its guidelines for implementing the scheme has fixed the rate of incentive for each of the identified categories of cargo. For transportation of bulk or breakbulk cargo pertaining to the seven commodities, the shipper will be eligible to get incentive at the rate of Rs 1 per ton per nautical mile up to a maximum of 1,500 nautical miles in each trip starting from origin and ending at the destination. Transportation of any commodity in containers in full container load will be eligible for an incentive at the rate of Rs 3,000 per TEU. The transportation of any commodity through forty feet or other larger sized containers will be incentivized based on number of times the said container size can be converted into TEUs. In case of vehicles transported through Ro-Ro vessels, the rate of incentive has been fixed at Rs 300 per two-wheeler, Rs 600 per three-wheeler and Rs 3,000 for other vehicles.

The SIMSC will be implemented using the Port Community System. The shippers eligible for grant of incentives under the scheme have to register on PCS at the Indian Ports Association website. The PCS is a single technology based platform that brings together all stakeholders and shares information on cargo movement at ports. It is managed by IPA.

By 2020, the government hopes that the Jal Marg Vikas project will enable commercial navigation of at least 1,500-tonne vessels to Allahabad round the year, as well as cruise tours connecting religious places. At present, cruise ships operate between Kolkata and Varanasi for about eight months in a year.

Meanwhile, the government is formulating a cabinet note for Rs 1,050 billion investment in national waterways projects. Of this, Rs 250 billion will come from the government while Rs 800 billion is likely to be garnered from the private sector to accomplish the target of building national waterways through public-private partnership.

2.2.3 Possible application of policies and subsidies

Deriving from the above discussion on current challenges of the IWT in India first set of ideas have been collected and are discussed hereunder.

A review of the public sector investment in the transport sector since the First Five Year Plan reveals that the average investment in the shipping sector per plan was only 5% as against 60% for railways and 50% for road sector. Even this meager investment was almost entirely allocated to overseas shipping and ports sector. In the port sector also, very little investment has been made by the maritime states on the development of minor ports and by the central government for major ports on creating earmarked facilities for inland cargo.

Globally, countries are adopting freight modal shift programs by providing incentives as a financial reward for switching the shipping method of choice from truck to rail or marine. The ground for such an incentive is that this shift would generate social benefits that offset the cost of the incentives provided. Countries like, Australia, UK, China, Brazil, Canada are resorting to reducing their emission levels by rationalizing their transport systems. Most countries are contemplating promotional mechanisms by way of grant assistance to viable modal shift from road to rail or waterways.

2.3 Policies and subsidies to the favor of IWT in Europe

The policy instruments that are applied for promoting IWT differ between European Union (EU)-level and the national and sub-national levels, because of different political competences.

A. EU-level policy instruments

The most important instruments on European Union-level in the last decade up to today have been:

- Co-funding of infrastructure projects through a Fund for the development of the Trans – European Network for Transport (TEN-T). This fund is to encourage Member States to invest in infrastructure (including port infrastructure) which is of international importance to Europe. The fund, recently renamed into Connecting-Europe-Facility, cofinances up to 20% of the infrastructure works and up to 50% of studies in the preparation phase like feasibility studies, design studies and environmental impact assessments. To some extent it can also provide co-funding of infrastructure related facilities like Liquefied Natural Gas (LNG)-bunkering facilities and port information systems. The remaining part of funding usually is provided by the relevant lower level authorities and sometimes by private sector.
- Co-funding of research and development studies. The studies are mainly of large scale and with good representation of the relevant market players and other stakeholders. The study topics closely follow the political agenda. Currently the for example address technological innovations like for cleaner engines, cargo handling systems, improved port operations, optimizing information flows between operators and authorities, information and communication systems for navigation, and supply chain optimization etcetera.
- Co-funding of pilots or other implementation steps for transport quality and efficiency improvements on similar topics as mentioned above, for example for pilots of implementing port information systems or for developing a network of LNG-bunkering and related training of port staff on security issues.
- Co-funding of modal shift actions. The instrument Marco Polo II opened for IWT companies in 2007. The instrument supports IWT-operators by taking a share of the risk in the start-up phase of a new service. The EU-contribution is always below the operational losses in the first 3 years of operation and required is a business plan that demonstrates viability of the service at the latest after 3 years.

An instrument which is specific for IWT concerns the instrument of Scrapping Fund. This fund is a heritage of national-level regulations of the IWT-sectors before their reform in the 1990s. It is a mechanism for controlling the capacity of the fleet by arrangements of “scrapping regulation” and “old for new regulation”. The former regulation is a levy to all active IWT-operators for filling the fund, the latter requires that those adding capacity to the market (new vessels) must either scrap vessel capacity or pay a levy for each added ton of capacity, which then will be revenue to the Scrapping Fund. The levies for the scrapping regulation and the factors that determine the scrapping requirement (and levies) in the old-for-new regulation reflect the market situation and may differ between market segments. The fund can only be used for barges which are part of the “active fleet”, meaning that the owner must provide evidence of good technical condition and of a minimum number of voyages done in recent years.

The role of the government in this regulation is to approve the levies and factors applied in the instrument and proclaim the instrument active. That is to provide a legal basis to the compulsory levying to all IWT-operators and the attribution of the Fund to scrapping. The Government also will manage the fund and enforce implementation.

The instruments applied at EU-level are presented in more detail in the following subchapters. In this respect, also references to recent cases of application are provided and first remarks concerning the transferability to the Indian case are being given.

B. Instruments on national and sub-national levels

National levels and sub-national levels have prime responsibility of infrastructure development and have instruments for a better use of infrastructure.

Improving of infrastructure is a national (or lower) level responsibility because European Union has no authority over territories. The approach of infrastructure planning is similar between European countries and typically comprises long-term (10-20-years) master planning of regional and infrastructure development, more specified and prioritized in medium term (3-5) plans and in annual infrastructure plans. Development of large-scale infrastructure follows similar project cycles, set by regulation, in order to have consideration of all interests, social and private, in the decision making process. Steps include:

- Pre-feasibility studies, comparing alternative solutions and usually including a preliminary assessment of their economic and financial returns. Feasibility studies, detailing the design, possibly with variants, and with more profound assessment of economic and financial feasibility.
- Environmental impact assessments if projects exceed a certain size. (Environmental Authorities will be leading for decisions on the need for EIA environmental impact assessment).
- Stakeholder consultation for an inventory of all interests, for example for aligning private and public interests or else for compensation and/or resettlement.
- Project consent commonly requires the previous steps. Large-scale inland waterway projects are likely to require approval certificates from relevant authorities, if there are potential impacts on e.g. (ground) water levels, special areas of conservation or protection areas.
- Project realization, comprising ground preparation, construction and delivery. This will follow an approved project implementation plan with well-defined project control and risk management and with clear definitions of deliveries and approval criteria.
- Project evaluation an understanding of the realized impacts and may lead towards additional measures for improving the use of the infrastructure.

The project cycle must ensure that public spending is in accordance with efficiency principles and that sustainable planning standards are met.

The responsibility of infrastructure maintenance and infrastructure operation (traffic management and for example locks and moveable bridges) also lies on these political levels. The distinction between National, Provincial or Municipal ownership and responsibility reflects the level of significance of infrastructure to the different levels and is demarcated by Public Law.

Either level may have specific instruments for enhancing infrastructure development. An example is instruments for co-funding of quay or terminal improvements between public and private sector entities.

National and sub-national instruments also comprise measures for improving the use of IWT-infrastructure. Those which have recently applied in EU-member states are for example:

- co-funding for piloting or developing innovations, similar to those co-funded on EU-level however with smaller scales and mainly national relevance;
- subsidies to reduce terminal handling costs for containers or intermodal loading units;
- co-funding of investments in transshipment terminals. Such investments are subject to the requirement that terminals will have public access;
- co-funding of waterway access and construction to dedicated quays, provided that the beneficiary commits to a minimum amount of annual shipment to barges;
- subsidies of modal shift scans, which comprise feasibility studies and business plans for the implementation to shippers for shifting their cargo from road to railways or inland waterway transport;
- modal shift subsidies, for example a fixed subsidy per TEU-kilometer (this instrument nowadays is out of grace).

Sometimes national, lower level governments or port authorities support market driven initiatives, like for example the establishing of IWT Promotion Bureau by co-funding or by assigning of manpower to their projects.

Recent examples of national funding programs in favor of IWT in Europe include aid schemes for green and low-emission waterway vessels in the Netherlands (Energy Investment Allowance), Germany (aid program for low-emission diesel engines for inland navigation vessels) or Austria (aid scheme for green inland waterway vessels) as well as support schemes for intermodal transport of containers on waterways in France and Belgium.³⁶

Sometimes national, lower level governments or port authorities support market driven initiatives, like for example the establishing of an IWT Promotion Bureau by co-funding or by assigning of manpower to their projects. The Short-Sea Shipping Inland Waterway Promotion Center (SPC) in Germany represents an application case for this kind of public support for the IWT sector.³⁷

2.3.1 The European Union Marco Polo Program

About the program

Marco Polo aimed to ease road congestion and its attendant pollution by promoting a switch to greener transport modes for European freight traffic. Railways, sea-routes and inland waterways have spare capacity. Companies with viable projects to shift freight from roads to

³⁶ For more information on various national funding programs for inland waterway transport, see http://www.naiades.info/funding/news.php?id=247&f_lang=EN (accessed 26 Jan 16)

³⁷ See <http://www.shortseashipping.de/> (accessed 01 Feb 2016)

greener modes turned to Marco Polo for financial support. More than 500 companies have done so successfully since the program was launched in 2003.

Responsibility

Marco Polo is run by the European Commission's Directorate-General for Mobility & Transport and the EU's Innovation and Networks Executive Agency (INEA). INEA is responsible for the operational side of the program - putting it into action on the ground and liaising with participants.

Objectives and funding areas

Marco Polo co-funded direct modal-shift or traffic avoidance projects and projects providing supporting services which enable freight to switch from road to other modes efficiently and profitably. Funding is in the form of an outright grant. It is not a loan to be repaid later. Applicants must meet a series of conditions to obtain a grant. Grants covered a share of costs associated with the launch and operation of a new modal-shift project, but must be supported by results.

A grant gave financial support in the crucial start-up phase of a project before it pays its way to viability. Grants last from two to five years. Projects should be commercially viable by the time the funding stops. Successful participation in a Marco Polo project enhances a company's green credentials. Marco Polo is user-driven. If a company has a project to transfer traffic from road to other modes or to avoid road transport, it may qualify for a grant. The project has to involve a cross-border route. It has to make economic as well as ecological sense. The selection criteria are set out in the grant application documents. Commercial undertakings, whether privately or publicly owned, can apply for funding.

In total there are five funding areas:

1. *Modal shifts from road to rail and waterborne systems:*

Most applications are for direct modal-shift projects. You do not have to shift all your traffic off the road to obtain a grant. Inter-modal projects, combining the different transport modes - road, rail and waterborne transport - are eligible.

2. *Catalyst actions which promote modal shift:*

These must be breakthrough, technology-driven projects, providing supporting services for modal shift like management systems, integrated cargo control via GPS, or common IT platforms for inter-operability between modes.

3. *Motorways of the sea between major ports:*

Motorways of the sea actions offer an effective way of getting big volumes of freight off the roads and onto ships. They must be innovative and inter-modal, and operate between Category 'A' European ports fully equipped to handle this traffic. Category 'A' ports are defined in an official EU decision.

4. *Traffic avoidance:*

The cleanest journey is the one that does not take place. Marco Polo therefore promotes traffic avoidance by funding projects which introduce new ways of avoiding or reducing road traffic, such as avoiding empty runs or improving supply chain logistics.

5. *Common learning actions:*

Projects related to enhanced knowledge and cooperation in inter-modal transport and logistics are a regular feature among funded projects. Different award conditions apply for this category.

Budget

The overall Marco Polo budget for the period 2007-2013 was €450 million. Applications for grants hit a record level in 2009 and 2010. Competition for funds is therefore keen. To put all applicants on an equal footing, requirements are kept simple and procedures are as transparent as possible.

The Marco Polo program publishes a call for proposals from potential grant applicants at the beginning of each year on its website. To meet the funding requirements are a criterium for success.

The decision to give funding to a project is based on the following basic principles, with variations for each funding area:

- Amount of freight shifted from road to greener modes (or the amount of road transport avoided),
- Fixed rate of subsidy,
- Maximum duration,

- Ceiling on the costs covered.

Applications must show the need for the subsidy by being loss-making during the subsidy period. But equally, they must show how their project will return to a sustainable profit from the time the subsidy ends.

The amount shifted is expressed in tons-kilometers per year. The minimum threshold is 60 MMT/km for modal shifts (13 MMT/km in the case of pure inland waterway projects), 30 MMT/km for catalyst actions, 200 MMT/km for motorways of the sea and 80 MMT/km for traffic avoidance. In certain cases, it is possible to measure in m³/km (a fixed conversion factor of 4m³/km = 1 ton/km applies). For traffic avoidance actions, vehicle/ kilometers (v/km) can be used. This criterion does not cover common learning actions, where a minimum subsidy threshold of €250,000 applies. The subsidy rate for all types of projects is €2 per 500 tons/km. Traffic avoidance projects can also use a rate of €2 per 25 vehicles/km.

The duration of grant is two years in the case of common learning actions, a maximum of three years for modal shifts and three-to-five years for catalyst actions, motorways of the sea and traffic avoidance.

The upper limit of eligible costs is 35% for all categories except for common learning actions where it is 50%. Eligible costs are those necessary to implement the project. They do not include return on capital, debt and debt service charges, or value-added tax (VAT), or costs incurred in non-participating countries.

Implementation and results so far

The contract document for each successful project is the Marco Polo grant agreement. It is negotiated and signed by the beneficiary or beneficiaries on the one side and the INEA on behalf of the European Commission on the other. The agreement is based on the applicant's proposal and takes account of comments made by the evaluation committee.

Over the period 2003-2009, 125 projects involving more than 500 companies have received funding from the Marco Polo program. Most projects benefiting from the program are modal shift actions. They accounted for 79% of the funding. These are projects which can viably shift freight from the road to other forms of transport in current market conditions, and where operational losses incurred during the start-up period can be covered by a Marco Polo grant. Common learning actions accounted for 9% of the funding and catalyst actions accounted for 8%. Traffic avoidance projects and motorways of the sea projects accounted for 2% of the funding each, but these categories have only existed since 2007.

70 projects were selected for grants in the period 2007-2009, i.e. the first three years of the Marco Polo II program. The maximum subsidy amount per project ranged from €0.37 million to €7.5 million. These projects aim to take a total of 54 billion ton-kilometers of freight off the roads each year. The total benefit to society as a result of avoiding the environmental and social costs of road freight traffic is estimated to be worth €1.4 billion.

Under the 2010 call for proposals, 32 projects were successful - from 101 bidders for the budget of €63.54 million. Of the 32 projects, 26 were modal shift actions, i.e. robust, but not necessarily innovative projects which take freight off the roads. Four were common learning

actions i.e. they innovate in ways of dealing efficiently and sustainably with increasingly complex transport and logistics solutions. There was one traffic avoidance action, transport and production, and one motor-way of the sea action i.e. an action offering a door-to-door service by combining short-sea shipping services with other modes of transport. No catalyst actions were selected in 2010.

Of the 27 projects that have been selected for funding during the 2013 call of the Marco Polo II program, 4 projects concern IWT. As they address the transport of different types of freight within specific geographical boundaries, they might provide general examples for commodities and markets (i.e. in terms of distance) that could potentially be addressed by respective programs in India. In detail, the elected proposals during the 2013 call include projects on the strengthening of barge logistics between Duisburg and the Belgian ports of Antwerp and Zeebrugge (Logport-Project), the transport of newly produced vans between Düsseldorf and the port of Antwerp (B2S), the shifting of containerized freight onto the waterways between the seaports of Antwerp and Rotterdam and their hinterland in northern France (FFCL) as well as the establishment of a regular waterway transport service for biomass and renewable resources between Romania/Bulgaria and Austria (Biolinks).³⁸

Figure 7: Marco Polo- facts and figures

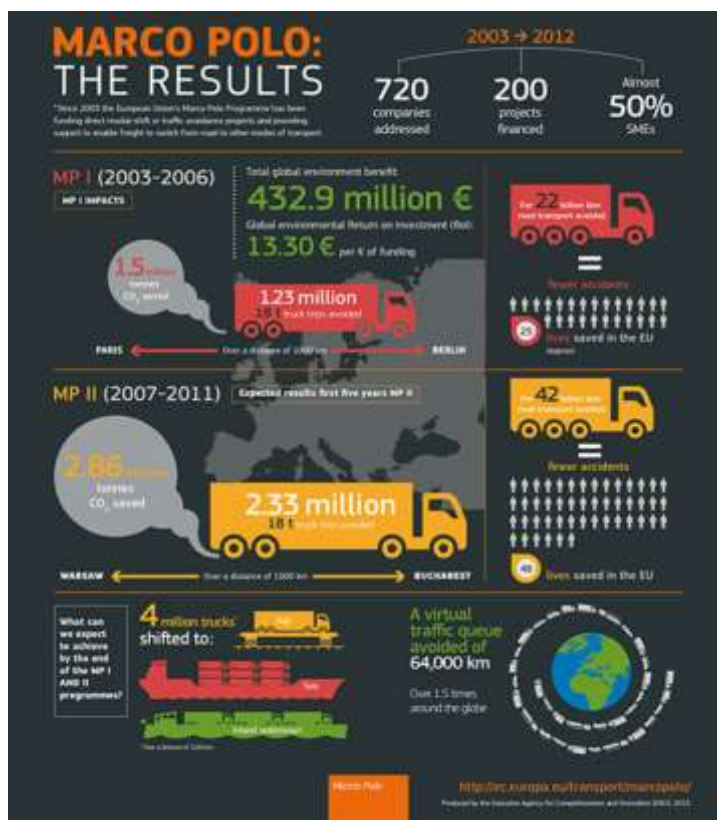

³⁸ For a full list of the projects selected under the 2013 Marco Polo II call, see http://ec.europa.eu/inea/sites/inea/files/download/marco_polo/marco_polo_award_decision_2013_smaller.pdf (accessed 26 Jan 16)

2.3.2 The EU funding program TEN-T (Connecting European Facilities CEF)

The Trans-European Network – Transport (TEN-T) Program was established by the European Commission to support the construction and upgrade of transport infrastructure across the European Union.

The TEN-T Program dedicated financial support towards the realization of important transport infrastructure projects - in line with the overarching goal of European competitiveness, job creation and cohesion.

The TEN-T Executive Agency (EA), created by the European Commission in 2006, managed the Program on behalf of the European Commission for all projects established under the 2000-2006 and 2007-2013 funding schemes. The projects represent all transport modes – air, rail, road, and maritime/inland waterway – plus logistics and intelligent transport systems, and involve all EU Member States. On 01 January 2013 the TEN-T EA became the INEA, but management of all open TEN-T projects continues unaffected.

€8 billion were attributed by the EU to the TEN-T program for 2007-2013, in order to support studies or works which contribute to the TEN-T program objectives. To allow this funding to ultimately improve the European transport network and increase mobility, there is a specific sequence of activities which need to take place in order to award it. These are summarized below.

TEN-T funding opportunities are open to all EU Member States or, with the agreement of the Member States concerned, international organizations, joint undertakings, or public/private undertakings or bodies. Funding in TEN-T grants can support studies or works which contribute to TEN-T program objectives.

This €8 billion budget over the 2007-2013 funding period was primarily allocated to projects selected via calls for proposals launched each year by DG MOVE and, as of 2009, by the former TEN-T EA on its behalf. The norm was that, each year, a Multi-Annual Call and an Annual Call were launched. The funding quotes differ from 10% to 20% for infrastructure projects up to 50% for pre-feasibility studies.

Overall, the Multi-Annual Calls aimed to give an important impetus to the implementation of the TEN-T priority projects - as defined in the TEN Guidelines - and to address some horizontal priorities.

The Commission (DG MOVE), with the assistance of the Agency, carries out the evaluation and selection of submitted proposals. The process is supported by independent external experts, whose role is to ensure that only the most high-quality proposals which best meet the award criteria as described in the relevant work program and call text are selected for funding.

Proposals, which meet the eligibility criteria specified for a call, are evaluated on the basis of the criteria defined in the relevant work program and call texts. Essentially, these relate to:

- relevance to the TEN-T priorities and policy objectives,
- maturity,
- impact - particularly on the environment, and
- quality (completeness, clarity, soundness and coherence).

A list of proposals recommended for funding is then prepared by DG MOVE with the support of the Agency, taking into account the opinion of the external experts.

Successful applicants are then invited by the Agency to enter into negotiations on the basis of which, if agreement is reached, individual Commission Decisions are established to support individual projects.

TEN-T projects involving waterways can be grouped into:

- Inland waterways are made up of rivers, canals and the various branches and links which connect them. The TEN-T inland waterway projects aim to help connect industrial regions and urban areas and link them to ports. Inland ports form part of the network, in particular as points of interconnection between the waterways and other modes of transport.
- River Information Services (RIS) and its related projects involve traffic management infrastructure on the inland waterway network. Specifically, this includes the establishment of an interoperable, intelligent traffic and transport system to optimize the existing capacity and safety and improve interoperability with other transport modes.
- TEN-T projects dealing with seaports aim to permit the development of sea transport. They include support for shipping links for islands and the points of interconnection between sea transport and other modes of transport. Their infrastructure aims to provide a range of services for passenger and goods transport, including ferry services and short and long-distance shipping services, coastal shipping, linking EU Member States together and with third countries.

In the past, various IWT projects have been funded under the TEN-T/CEF-program. Recent examples from the 2014 program include a study/pilot-action on the removal of bottlenecks on the Danube River in the cross-border region between Bulgaria and Romania, as well as actions on the improvement of the inland waterway network in northern Italy, the development of a multimodal terminal on the Rhine River at Lauterbourg and the implementation of a river information system on Belgian inland waterways, contributing to a better traffic management and a more efficient and safer navigation.³⁹

The trans-European network of Motorways of the Sea (MoS) intends to re-create the road and rail network on the water, by concentrating flows of freight in viable, regular sea routes. These projects strive to improve port facilities and infrastructure, as well as electronic logistics management systems, safety and security and administrative and customs procedures, as well as access routes for year-round navigability. Projects usually are proposed by at least two member states.

2.3.3 The EU funding program INTERREG IV A Upper Rhine

The INTERREG community initiative was launched in the 1980s by the European Commission, under the responsibility of the Regional Policy Directorate General. Regional Policy enjoys the second biggest budget in the European Union, after the Common Agricultural Policy.

³⁹ For an overview of recent waterway-related TEN-T/CEF projects and project-specific information, see <https://ec.europa.eu/inea/en/connecting-europe-facility/cef-transport/projects-by-transport-mode/water> (accessed 29 Jan 16)

Following a pilot phase (1989-90), the program was extended to cover the whole of the European Union, with INTERREG I (1990-93), followed by INTERREG II (1994-99) and INTERREG III (2000-06). Allocated funds have increased regularly and the latest programming phase has been given € 4.9 billion by the European Regional Development Fund (ERDF). The visible success of the initiative is the main reason why it has been so willingly pursued.

The Upper Rhine area, where France, Germany and Switzerland share common borders, is of central importance for Europe, in terms of history, culture and economy. Cross-border cooperation, which involves over five million inhabitants, began in the 1960s and has accelerated under the INTERREG initiative.

Over the last fifteen years, the rising number of projects and players involved in cross-border cooperation has demonstrated the immediate and very real impact of the INTERREG initiative in the Upper Rhine. Within the two programming areas, PAMINA and Upper Rhine Center-South, INTERREG has provided the backing for some 300 projects to develop within a genuine spirit of partnership.

The Program "INTERREG IV A Upper Rhine" intends to sustain the cross-border cooperation in the Upper Rhine Valley. It is realized in a specific context, explained here.

The Program implemented in the Upper Rhine region is a part of the Objective "European territorial cooperation". This objective itself is a part of the Regional Policy of the EU. The Program is also, for the Swiss part (Switzerland is not member of the EU) part of the Swiss New Regional Policy. The Program is concerning a period of nine years between 2007 and 2015. The implementation is founded on a base document, the Operational Program.

The OP has been drawn up by the actors of the cross-border cooperation in the Upper Rhine region and adopted by the European Commission on 24 October 2007.

These are the objectives of the program:

- Support the development of the Upper Rhine into an internationally competitive cross-border knowledge and innovation Region
 - to extend through the promotion of projects with the aim of cross-border research capacity to strengthen cross-border participation of companies and to increase the development of applications and innovation through cross-border consortia
- Promote cross-border dimensions of a sustainable development of the area, the economy and the mobility of the Upper Rhine
 - through projects with the aim of improving the protection of species, the quality of the ecosystem services that reduce environmental burdens and resource use in the context of urban development and the economy of the Upper Rhine and the increase in the share of transport with lower load carrier
- Promote employment in the Upper Rhine cross-border
 - through projects with the objective of cross-border development of small or medium enterprises (SMEs), increasing the supply of jobs and the increase in cross-border employment

- Promote cross-border cooperation between administrations and citizens in the Upper Rhine
 - through projects with the aim of improving cross-border service offering of administrations and increasing the identification of citizens with the Upper Rhine as a cross-border region.

INTERREG programs contain projects on various subjects, including the promotion of transport services for goods and passengers in the respective cross-border regions. Transferred to the case of IWT on the NW-1, an INTERREG related program could thus present a platform for cooperation and exchange in the border regions between different Indian states or in the cross-border regions between India and Bangladesh. Among the different waterway-related projects funded by INTERREG in the Upper Rhine area are works such as the redevelopment of a ferry link between France and Germany as well as multi-modal transportation studies that aim to identify the strengths and weaknesses of the regional infrastructure and to find a cross-border basis for the analysis and assessment of transport related problems.⁴⁰

2.3.4 The EU funding program NAIADES

In 2006, the European Commission adopted a Communication on the promotion of inland waterway transport. The NAIADES Action Program was intended for the period 2006-2013 and focused on five strategic areas for a comprehensive IWT policy: market, fleet, jobs and skills, image and infrastructure. These measures are rounded off by reflections on an appropriate organizational structure.

Issues being addressed under NAIADES include working time arrangements, professional qualification requirements, the examination of administrative and regulatory barriers, the adoption of innovative technologies, such as the RIS, and infrastructure improvements.

By creating favorable conditions for the further development of the sector, the Commission hopes to encourage more companies to use this mode of transport. The policy to promote inland waterway transport in Europe is encapsulated in the NAIADES Action Program.

A first action program covered the period 2006-2013. A second action program, NAIADES II covers the period 2014-2020.

Carriage of goods by inland waterways is a climate-friendly and energy efficient mode of transport, which can make a significant contribution to sustainable mobility in Europe. The European Commission believes that its great potential must be better used in order to relieve heavy congested transport corridors.

The NAIADES action program comprises numerous actions and measures to boost transports on inland waterways. The program runs until 2020 and is to be implemented by the European Commission, the Member States and the industry itself.

⁴⁰ For more information on the INTERREG projects in the Upper Rhine area, see <http://www.interreg-oberrhein.eu/projekte/liste-der-projekte/> (accessed 29 Jan 16)

The revision of the NAIADES action program (2014-2020) is expected to lead to the adoption of the NAIADES II Communication foreseen in 2013. In its Staff Working Paper, the Commission Services presented concrete actions under preparation:

1. Infrastructure - planned actions for inland navigation under the existing programs and under the forthcoming instruments of the next multi-annual financial framework for the period 2014-2020 (financial and technical assistance);
2. Market - assistance for integrating inland waterways into the multimodal logistic chains; financial incentives for inland navigation;
3. Fleet - measures to reduce emissions (for example standards);
4. Jobs and skills - actions aimed at increasing harmonization of standards for professional training and certification; and
5. Information exchange and sharing - review of the River Information Services policy.

The NAIADES II Communication aims at creating the conditions for inland navigation transport to become a quality mode of transport. It sets out the program for policy action in the field of inland waterway transport for the period 2014-2020. Actions are taken in the following key areas of intervention:

- Quality infrastructure,
- Quality through innovation,
- Smooth functioning of the market,
- Environmental quality through low emissions,
- Skilled workforce and quality jobs, and
- Integration of inland navigation into the multimodal logistics chain.

The other elements of the package represent the first steps towards the implementation of the NAIADES II program. The Staff working document is a contribution to the impact assessment of future initiatives in relation to the greening of the inland waterway fleet, the Proposal for a Directive laying down technical requirements for inland waterway vessels prepares for the implementation of a new approach to governance in inland navigation and the Proposal for a Regulation amending *Council Regulation (EC) No 718/1999* intends to allow for a broader range of actions of the Reserve Funds available to support inland navigation. Moreover in the context of the RIS, the European Commission has adopted an implementing regulation which introduces a harmonized electronic chart display information system.

2.3.5 The EU funding projects PLATINA and PLATINA 2

The PLATINA project is a major trans-European project for the promotion of inland waterway transport. Launched by the European Commission in 2008, PLATINA was designed as a platform to provide support for the implementation of the NAIADES European inland navigation program. It brings together 22 partners from 9 European countries and has received Commission funding of €8.5 million.

The PLATINA project, adopted under the 7th Framework Program for Research and Technological Development, covers a broad set of actions in five strategic fields of NAIADES:

- Improve market conditions,
- Modernize the fleet,
- Develop human capital,
- Strengthen the image of inland navigation, and
- Improve infrastructure.

PLATINA provides technical and organizational assistance by ensuring active participation of key industrial stakeholders, associations and Member States administrations. Furthermore, PLATINA organizes expert meetings and working groups, and carries out studies on how to better implement selected actions. Other actions include the setting up a single portal for online inland navigation information services and an inland navigation education network, as well as the provision of technical support for the further development of River Information Services (RIS).

The project PLATINA 2 implements the European Action Program for the promotion of inland waterway transport (NAIADES 2). PLATINA 2 is effectuated by a consortium of 12 organizations from seven different countries. The consortium includes relevant stakeholder groups from the inland waterway transport sector.

In order to accomplish the objectives and intentions of the NAIADES 2 Action Program, the PLATINA 2 consortium includes the active participation of

- waterway operators and administrations,
- representatives of the inland waterway transport industry and fleet operators,
- promotion and development organizations,
- inland navigation educational and training institutions, and
- experienced consultants and research institutes.

PLATINA 2 comprises several bodies related to project management as well as internal and external communication and content-related steering.

Advisory Committee (AdCOM): responsible for the strategic guidance of the project's technical actions and recommendations. It consists of high-level representatives of Member States, third countries, river commissions, the IWT sector as well as the European Commission. Their acceptance of PLATINA 2's results is vital to the success of the NAIADES action program. The Advisory Committee usually meets in combination with the EC NAIADES implementation

group. Furthermore, it reviews the roadmap reports proposed by the Management Committee or discusses topical issues in course of the NAIADES dialogue.

Management Committee (MCOM): consists of senior representatives of the WP leader organizations which are responsible for the tactical planning and the internal agreement on roadmap reports for the platform and its work packages.

Executive Board (ExBoard): made up of representatives of the European Commission and the MCOM. It is in charge of strategic planning, resolving contractual and financial issues and monitoring support activities. The Executive Board meets at appropriate milestones. Occasionally, selected Member State Representatives are invited.

Technical Secretariat (TS): responsible for the day-to-day administrative and technical management of PLATINA 2 and consists of the WP leaders. It carries out the actions delegated to it by the Management Committee and the Executive Board. The Technical Secretariat is also the focal point for the organization of project-related networks and dissemination and exploitation of project results. This includes technical coordination and responsibility, coordination and liaison with the European Commission, financial administration, a communication desk, as well as a project back office.

Project partners: experts who provide technical expertise and inputs to the various work packages and activities. These experts are chosen from IWT industry representatives, Consultants, promotion agencies and administrations. Project partners will meet only as necessary to complete their specified tasks. A full consortium meeting together with the EC-Project Officer normally takes place once a year.

Involvement of external experts, stakeholders and subcontractors: in addition to the targeted one-directional information transmission under the PLATINA 2 umbrella, interactive involvement of stakeholders from within and beyond the sector takes place. This is carried out by various means, the most important being NAIADES dialogue and Thematic Expert Groups, which are adapted to the particular issue. The gathered viewpoints and expert knowledge are integrated in the project work. Synergies with existing initiatives and structures are exploited.

Project structure and objectives

PLATINA II provides technical and organizational support to the European Commission, Member States, third countries, River Commissions and industry in the development and deployment of targeted policy actions implementing the NAIADES II Action Program. Consequently, PLATINA II aims at fostering the development of inland waterway transport into a quality mode of transport. The project builds on close cooperation with administrative stakeholders on all levels, River Commissions, branch organizations as well as (potential) end users, freight forwarders, fleet and terminal operators, shippers and further relevant stakeholders, initiatives and projects. Their involvement is ensured by dedicated working groups, the Advisory Committee or NAIADES dialogue.

Organized along the priority topics of NAIADES II, PLATINA II comprises four work packages (“action fields”) dealing with specific policy areas:

- Markets and awareness,
- Innovation and fleet,
- Jobs and skills, and
- Infrastructure.

2.3.6 Conclusions on the Marco Polo and other EU incentive programs in respect of inland waterway transport in India

The overview of EU incentive and development programs to initiate Inland Waterway transport indicated the wide range of instruments, which deemed to be necessary for a mature EU transport industry, infrastructure and market driven forces deciding on which transport mode will be chosen to serve the market.

Summarizing the above overviews the most important instruments on European Union-level in the last decade up to today can be characterized as follows:

- Co-funding of infrastructure projects through a *Fund for the Development of the Trans – European Network for Transport (TEN-T)*. This fund is to encourage Member States to invest in infrastructure (including port infrastructure) which is of international importance to Europe. The fund, recently renamed into Connecting-Europe-Facility, cofinances up to 20% of the infrastructure works and up to 50% of studies in the preparation phase like feasibility studies, design studies and environmental impact assessments. To some extent it can also provide co-funding of infrastructure related facilities like LNG-bunkering facilities and port information systems. The remaining part of funding usually is provided by the relevant lower level authorities and sometimes by private sector;
- Co-funding of research and development studies, such as the INTERREG program. The studies are mainly of large scale and with good representation of the relevant market players and other stakeholders. The study topics closely follow the political agenda. Currently the for example address technological innovations like for cleaner engines, cargo handling systems, improved port operations, optimizing information flows between operators and authorities, information and communication systems for navigation, and supply chain optimization etc.;
- Co-funding of pilots or other implementation steps for transport quality and efficiency improvements on similar topics as mentioned above, such as NAIADES/ PLATINA, for example for pilots of implementing port information systems or for developing a network of LNG-bunkering and related training of port staff on security issues; and
- Co-funding of modal shift actions, such as Marco Polo. The instrument supports IWT-operators by taking a share of the risk in the start-up phase of a new service. The EU-contribution is always below the operational losses in the first three years of operation and required is a business plan that demonstrates viability of the service at the latest after three years.

The following *Table 5* provides a good summary of the previously described different IWT related and pure IWT incentive programs and their specific focus. While the TEN-T program has a very broad European Union scale covering mainly investments on general transport

infrastructure (among IWT), the Marco Polo Program rather focus on shifting cargo from road transport to railway or inland waterway transport.

Table 5: Focus of funding of different EU incentive and promotion programs

Programme / Project	Focus of funding												
	Infra-structure	Start of Operation / Market entrance	Innovation (Technology)	Optimization (Processes)	Supra-structure	Human capital	Fleet	Organisation / Administrative structures	Net-working / Cooperation	Environmental issues	Promotion	Safety / Security	
Marco Polo		X	X	X			X		X	X			
TEN-T	X	X			X				X	X			
INTERREG IV A Upper Rhine			X			X			X	X	X	X	
NAIADES	X		X	X	X	X		X			X		
PLATINA and PLATINA 2		X	X			X	X	X	X	X	X		

Source: Consultants

Concerning the transferability of the envisaged programs, one has to consider the specific conditions and needs of today's inland-waterway transport in India. In order to provide a competitive basis for the future development of the transport mode, further investments in adequate infra- and suprastructures such as navigable waterways, ports and terminals are likely to be necessary. In order to support such cost-intensive investments, the CEF/TEN-Tprogram might act as a suitable role model for a joint funding program that unites the financial means of national and state authorities as well as private investors. At a later stage, Marco Polo/PLATINA-like programs could then help to facilitate the market entrance of private businesses by encouraging a modal-shift of existing traffic and by providing technical and organizational support to market participants.

2.4 Policies and subsidies to the favor of IWT in China

The following examples refer to the policies and subsidies on IWT on the Xiang River in the Hunan Province. A variety of administrative funding methods could be seen from specific funding programs. The description on existing incentive programs and promotion packages for inland waterway transport - however extensive - should provide a look into the policy thinking which has already brought a major development and benefits to the Chinese IWT system. As the project's scope of work implies a visit of the IWT administration in the Hunan Province it was deemed to be helpful to provide a full set of background information.

Promotion of IWT in the People's Republic of China (PRC) has become objective because of IWT's contribution to an efficient and sustainable transport system. The Central Government's transport policy and regulations are powerful guidance to the implementation of policies on lower government levels, i.e. Hunan and its municipal levels. These local level authorities will pursue Central Government's objectives and policies, possibly only with amendments that would make policies more fit to specific conditions.

The Central Government has argued that the use of water transport on rivers has helped to optimize location and layouts of industries along rivers, for which economic development along the Yangtze River is taken as an obvious example. There, inland-waterway transport has demonstrated its unique advantages in transportation of energy, raw materials and other bulk materials as well as containers and major equipment.

The public sector entities are encouraged to accelerate measures to facilitate IWT-growth. The Chinese Government does recognize that the demand for and thus use of IWT in the end will mainly be a market factor and therefore market needs and potential should be well considered.

It is worth noting two points here: firstly, although certain government plans have not been given the effect of compulsory enforcement, but after government documents of the aforesaid feature are promulgated, the Central and Local Governments at various levels will proceed to enact detailed supporting laws and regulations to ensure the contemplated objectives of government documents can be effectively realized. Relevant government documents would generally clearly indicates the government-expected orientation of Xiang River shipping business development; in the analysis of government incentive measures on encouraging Xiang river inland waterway transport development, relevant government documents are not only of reference value but also of indispensable practical significance.

Secondly, after the Central Government promulgated laws and regulations, in some cases, the local government will, for certain reasons and in consideration of actual local circumstances, enact related laws and regulations. Since local governments have no power to substantially alter the principles or provisions of laws and regulations promulgated by governments at a higher level, local laws and regulations are formulated on the basis of superior laws and regulations and in light of actual local circumstances to deal with more specific matters, so as to be more applicable.

The following sub-chapters refer to the six fields of action, which represent the focus of the incentives and promotion activities of the Hunan Province.

2.4.1 Modal shift from land transport to waterway transport

Through investigation and searching, the following policies or legislation contain relevant provisions on incentive measures on encouraging the shift from land transport to inland-waterway transport:

The National Plan for the Distribution of Inland Waterways and Ports (20 July 2007) sets out, to better guide inland waterway transport business toward the path of healthy development, to give full play to the advantages of inland waterway transport such as less land occupation, large shipping capacity, low energy consumption, and low pollution, to optimize the comprehensive transportation system, and to promote the comprehensive development and utilization of water resources.

It was suggested that measures shall be taken to give full play to the advantages of inland waterway transport, to provide uninterrupted transport services in a highly-efficient, safe and environmentally-friendly manner, adapt to the requirements of valley economic & social development of and national security. In the long run, according to the requirements of river

valley economic and social development, measure shall be taken to further expand the coverage of, enhance the accessibility, and extend the range of, inland-waterway services.

According to this plan, governments at all levels shall be committed to give full play to the advantages of inland-waterway transport, to strengthen its effective connection with other modes of transportation, and to optimize the comprehensive transportation system; to attach importance to coordination development between waterways and ports/ships, and between trunk waterways and tributary waterways.

Besides, relevant government offices shall have effectively connected major places of resource supply with places of resource consumption and realize direct river-sea transport involving major rivers. Further efforts may be made to further strengthen regional economic and material exchanges, to promote the formation of industrial concentration areas along rivers, and to give full play to the leading role of major cities for economic development in the region.

Additionally, governments at all levels shall be committed to develop a national system of inland waterways and ports, backed by high-grade fairways allowing navigation of ships over 1,000 metric tons, and operated by major ports nationwide, to promote standardization of transport vessels featured large size, to effectively develop and utilize inland water transport resources, to give full play of the advantages of inland water transport, and to create a comprehensive transport system integrating other modes of transportation.⁴¹

As is pointed out by this plan, its implementation can save a lot of land of the State; especially, building a network of high-grade waterways in regions in short of land resource such as the Yangtze River Delta, and Pearl River Delta is an effective measure to help relieve the pressure on land resources and expand the transportation capacity.

On 21 January 2011, *Opinions of the State Council on Accelerating the Development of Water Transport on the Yangtze River* were issued by the State Council. In relation to model shift, it was requested that governments at all levels shall devote the attention to realize an organic link between water transport with other modes of transportation involving highways, railways, aviation and pipelines, to develop multimodal transport, and to exert the comparative advantages and combination efficiency of various transportation means thus helping optimize the transportation structure, reduce comprehensive logistics costs of society, and transform the mode of transport development.

Moreover, it also emphasized that the development of water transport on rivers such as the Yangtze River helps adjust and optimize the layout of industries in areas along rivers; inland water transport has unique advantages in transportation of energy, raw materials and other bulk materials as well as containers and major equipment; Speeding up the development of inland water transport is conducive to development of the electric power, steel, automobile and other sectors in regions along rivers. Further, to accelerate the development of inland water transportation on Yangtze River and other rivers is beneficial to energy conservation and emissions reduction. With the fast economic and social development, resource and environment constraints are getting increasingly stringent; the contradiction between transport development and energy conservation/environment protection has become increasingly acute. It is emphasized that a vigorous development of inland-waterway

⁴¹ For more information, see <http://siteresources.worldbank.org/EXTPRAL/Resources/china.pdf> (accessed 27 Jan 16)

transport helps cut down the energy consumption, build a low-carbon economy and reduce emissions, which is in line with the overall requirements of building a resource-saving and environmentally-friendly society, and is of great practical significance to speed up the transformation of the pattern of economic development.⁴²

It required that governments at all levels shall also be applied to fully implement the scientific outlook on development, further emancipate the mind, and take the development of inland waterway transport as a key task in the construction of a comprehensive transport system, to upheld the notion of scientific development, rationally utilize and effectively preserve water resources, as guided by the market and under the principles of highlighting priorities and orderly promotion, so as to give full play to the comprehensive functions of water resources, to fully stimulate the initiative of local People's Governments at various levels and social forces in contributing efforts to inland water transport development, to persist in making scientific and technological innovation, to strengthen the R&D work on advanced suitable technology and equipment, and to upgrade and sustain the development of inland waterway transport.

Governments at all levels shall be committed to strengthen the construction of railway and highway collecting and dispatching passageways for major ports, to realize connection of high-grade highways or express highways with major container ports of inland rivers; to promote development of major ports into cargo transit bases and commodities trading center, and gradually build them into a comprehensive freight hub; to strengthen the supervision on plan enforcement, strictly implement the examination and approval procedures for the use of coastlines, encourage the development of public piers, and to improve the utilization efficiency of coastline, land and other resources.

Furthermore, governments shall make efforts to speed up the development of large-scale port areas for special purpose at major ports and part of the key ports along inland rivers, and focus on building a series of terminals specially for handling containers, automobile rollon /roll-off (ro-ro) handling, and bulk commodities; to improve the collecting and dispatching system of inland river ports; in light of the national and local road and rail network planning, to strengthen the planning specially for the collecting and dispatching system of main ports and key ports, and incorporate the planning into the local overall planning for implementation; to enhance technological standards of dispatching passageways of key port areas, to connect high-grade highways with express highways in large container terminals, to realize direct transport "between port and railway station" in port areas having a strong railway-port transport function for bulk and container cargoes, and to ensure a proper quantity and standard of railway lines and marshaling stations in port areas.

Besides, governments at all levels shall be addressed to develop multimodal transport and port logistics, actively encourage large inland ports having a railway-port transport function for bulk and container cargoes, a beneficial geographical location, a large throughput capacity and professional outstanding features to better their warehousing facilities and port environment, to expand their logistics functions and play their pivotal role as transport hubs; to accelerate the development of inland water container transportation, promote specialized inland transportation for automobile ro-ro handling, liquid bulk cargo, bulk cement and over-

⁴² For general information on low-carbon economy policy in China, see <http://www.cciced.net/enciced/policyresearch/report/201205/P020120529358137604609.pdf> (accessed 27 Jan 16)

sized and heavy-weight cargoes, to expand the transport range of sea-river and trunk-feeder lines.; to speed up the process of standards cohesion, information sharing, transport deployment and service integration of inland waterway transport and other means of transportation. Relying on demonstration projects carried out by low-carbon and bulk-cargo transport pilots, to investigate the waterway transport market and provide guidance on formation of market mechanisms and policies.

Although there are national level plans and they are well known by local officials, local policy and legislation seemingly is not in pace with central ones. The above legislation and regulation are promulgated by central government organs, being programmatic documents applicable to broad geographical areas across the nation; however, it requires specific policies based on local actual circumstances to guide the transport sector toward the shift in modes of transportation. Government documents at central level could not and should not set out unified detailed implementation programs and need further promulgation of supporting measures by local governments according to local actual circumstances.

In addition, even though the government showed their ambition and destination to exploit potentialities of IWT which is considered as another economic growth engine, a clear delivery plan accomplished by quantitative indicators that is proved effective by the Marco Polo Program is still necessary. What is more, it has to be accepted that the modal shift will lead to sacrifice of interests in other transport modes and change of past pattern of economic growth.

2.4.2 Encouraging establishment of inland waterway transport service companies

In 2009, *Regulations of Hunan Province for Administration of Waterway Transportation* was issued by the Standing Committee of National People's Congress of Hunan Province, where the Hunan Province Government is required to encourage domestic and foreign units and individuals to establish waterway transport undertakings and on investing in establishment of waterway transport enterprises, implement the principle of "those who invest shall get benefits".

The Ministry of Transport made the *Opinions on Implementation of Opinions of the State Council on Accelerating the Development of Water Transport on the Yangtze River and Other Inland Waters in 2011*. In accordance with Article 2.6, transportation departments at all levels shall be applied to vigorously develop modern shipping sector involving shipping trade, consultancy, information, finance, insurance and other services; to continue promoting corporate operation of inland waterway transport, guide the small and medium-sized shipping companies toward the path of intensive development in large-scale operation mode, to promote intensive management of dangerous goods transport in large-scale operation mode; to encourage transport and port service enterprises to extend the industry chain, to expand the service functions such as warehousing, distribution and logistics, so as to turning themselves into logistics operators.

2.4.3 Encouraging recycling of ship wastes

Governmental transportation departments at various levels shall be committed to strengthen the control of mobile source of ship-induced pollution, equip newly-built inland transport

vessels with bilge disposal (or storage) and sewage/garbage collection facilities, renovate existing passenger ships (including truck ro-ro vessels) in key water areas by equipping them with related facilities, and build a monitoring and testing system for ship-induced pollution; to establish an emergency response mechanism for pollution accidents in inland waterway transport, and to equip vessels with pollution treatment facilities; to build onshore facilities at waterway service areas and ports for receiving and treating domestic garbage, bilge and sewage of vessels.

Specifically in the *Implementation Plan for Pollution Prevention and Control in Zhuzhou Section of Xiangjiang Changsha Comprehensive Junction Reservoir Area*, issued on 19 October 2012 by the People's Government of Hunan Province, it required measures on pollution prevention and control on transport vessel and port terminals shall be carried out. Strict restraints shall be placed on transport of dangerous chemicals, and it is forbidden to flush vessels clean or directly discharge domestic garbage/bilge of vessels into the reservoir area. Temporary piers in the reservoir area shall be removed, the berths at retained piers shall be rationally allocated, and the reservoir shall be delimited into various areas. To clear out unnecessary floating oil jetties, floating filling stations (points) and refueling stations, clamp down on illegal floating gas stations (points), and prohibit vessels from dumping wastes or oily water into the reservoir area.

The Water Resource Department of Hunan Province issued the *Regulations of Hunan Province on Protection of Xiangjiang* on 01 May 2013. According to this regulation, ship navigating in navigable waters of the Xiang River shall have legal and valid certificates of water pollution prevention, and shall be equipped with facilities for collection of pollutants such as sewage, waste oil and garbage. It is forbidden to discharge or dump pollutants and ship wastes. In addition, the people's government at the county level shall organize relevant units to get floaters and harmful algae out from the trunk streams and major tributary streams of the Xiang River under its governance, and dispose of them in a bio-safe manner.

In the following month, the Administration of Water Transportation of Hunan Province issued the *Notice on Strengthening Prevention and Control of Ship-induced Pollution in Xiangjiang Changsha Junction Reservoir Area*. It required ships navigating in the Xiang River Changsha junction reservoir area shall be equipped with bilge tanks and sewage tanks, and are prohibited from discharging sewage and bilge into the reservoir area; garbage containers or bags shall be prepared for storing ship garbage in the process of transport; ships entering the reservoir area shall timely notify garbage collecting units for removing ship garbage and sewage. For each single voyage passing the Xiang River, ships shall make delivery of garbage to the collecting units at a time; ships navigating within Hunan Province shall deliver garbage not less than twice per month; ships navigating within the reservoir area shall deliver bilge and sewage not less than once per month. Since 01 January 2014, ships not equipped with bilge tanks or sewage tank or garbage cans have been prohibited from entering the Xiang River comprehensive junction reservoir area.

Some relatively specific measures are found in *Management Measures on Subsidy on ShipClass Standardization on Inland Waters*, which was promulgated by the Ministry of Finance and the Ministry of Transport on 09 April 2014. Article 13 provides that the subsidy standard for conversion of existing vessels to prevent pollution by vessel sewage is calculated by the following methods:

Install facility to treat sewage:

1. Passenger vessel: $\text{unit vessel subsidy} = \text{subsidy base} + \text{unit passenger seat subsidy} \times \text{passenger holding capacity of the vessel}$.

For the calculation, the subsidy base is Chinese Yuan (CNY) 90,000; unit passenger seat subsidy is CNY 1,100 per passenger seat; passenger holding capacity of the vessel is subject to Ship Inspection Certificate.

2. Cargo vessel: vessel with a gross tonnage under 1,000 tons can get a subsidy of CNY 30,000; vessels above 1,000 tons but under 2,000 tons can get subsidy of CNY 40,000; vessels of or over 2,000 tons can get subsidy of CNY 50,000.

Install storage cabin (hold) to collect sewage:

For each vessel, vessels under 1,000 tons can get subsidy of CNY 15,000; vessel above 1,000 tons but under 2,000 tons can get subsidy of CNY 20,000; vessel of or above 2,000 tons can get subsidy of CNY 25,000.

In the Notice on Promoting the Implementation of Ship-Class Standardization on Inland Water in Hunan Province, it is provided that as of 01 January 2016, inland water vessels of which sewage collection fails to meet the current standards, chemical cargo vessels, and single-deck tankers (>600 ton) are forbidden to sail on certain waters of Xiang River, Yuan River, and Dongting Lake. From 01 October 2013 to 31 December 2015, the installation of sewage treatment or collection facilities on vessels which meet the conversion requirements can get subsidy from the government.

2.4.4 Technological innovation of inland water vessels

The Consultants note in the *Implementation Opinion of Hunan Provincial People's Government on Encouraging, Supporting and Guiding the Development of the Non-Public Sector of Economy including Individual Sector and Private Sector*, issued by the Hunan Provincial People's Government on 22 July 2005, that Hunan Province Government will be committed to improve services for technological innovation; to give full support to the technological innovation and to the application, approval, finance arrangements and project management of all kinds of technical program. Non-public enterprises enjoy equal treatment to that of public enterprises; the verified non-public hi-tech enterprises enjoy equal favorable treatment to that of public hi-tech enterprises.

Besides, the local governmental organizations at all levels should turn to provide funds to establish platforms of generic technology and public service such as R&D center, test center and information center in key industrial clusters and industrial parks, so as to encourage non-public capitals to establish incubators for all kinds of technology enterprises.; to encourage non-public technology enterprise which possess feasible conditions to cooperate with universities and colleges, and scientific research institutes to set up technology development institutions of all kinds which can pool in resources and wisdom of industry, education institutes and research institutes to solve problems; to encourage and support non-public enterprises to form hi-tech research & development (R&D) centers and engineering technology centers, and to set up postdoctoral work stations and experimental bases.

It is required that the local governmental organizations at all levels should be applied to vigorously foster the technology market, support key cities which possess feasible conditions to set up technology exchanges, with a view to promote the transformation of technological achievements and transfer of technology. Encourage intermediary technology service agencies to provide technology information, technology consultation, and technology promotion and other professional services. Encourage state-owned research institutions open laboratories to non-public enterprises. The costs incurred by the research and development of new products, new technique and new technology by profit-oriented industrial enterprises have increased by more than 10% (including 10%) compared with that of last year. The actual cost of the year, after disbursed from the cost and expenses based on actual situation as per the provisions, can directly deduct the due income tax of the year by 50% of the actual cost of the year. Encourage retired personnel to provide management expertise and technical expertise for enterprises. To effectively protect the intellectual property rights of entities and individuals, to provide funds for the application and protection of invention patent of non-public enterprises.

The *National Outline for the Development of Ship-Class Standardization on Inland Water*, which was published by the Ministry of Transport on 14 February 2006, suggested that governmental transportation departments at all levels shall make efforts to develop navigation industry by relying on technology, positively introduce advanced technology, and promote the close combination of technology progress and market economy development by taking into account of economic development and market bearing capacity.

The Ministry of Transport's *Guiding Opinions on Promoting the Development of Green, Recycling-oriented, and Low-carbon Transportation*, issued on 22 May 2013, emphasizes governmental transportation departments at all levels shall be committed to strengthen technological research and development on green, recycling-oriented and low-carbon transportation; to promote the breakthrough of major science and technology programs including the R&D and application of key technology for intelligent transportation based on the internet of things, and the research and demonstration of the key technology for emergency response to transportation pollution and pollution control; to proactively promote key technology, advanced applicable technology and product R&D in the fields of energy saving, ecological environment protection and utilization of new energy for transportation energy sector. In addition, governmental transportation departments at all levels shall be committed to strengthen the promotion of the technology and products of green, recycling-oriented and low-carbon transportation; to step up the research and formulation of policies for the technology of green, recycling-oriented and low-carbon transportation; to make public of the achievements directory of the technology, product, and technique of the green, recycling-oriented and low-carbon transportation in a timely manner, and actively promote the market-integration and industrialization of technological achievements.; to vigorously promote the construction the system of criteria, measurement and inspection, and verification for the technology, products, and techniques of the green, recycling-oriented and low-carbon transportation.

In the *National Implementing Plan of Promoting Ship-Class Standardization on Inland Water during the 12th Five-Year Plan* promulgated jointly by the Ministry of Transport and the Ministry of Finance and in conjunction with the people's government of more than ten

provinces, it is demanded that governments at all levels shall strengthen and support the fundamental and forward-looking research on new type of vessels and energy-saving transportation modes.

In the *Notice of the Ministry of Transport on Issuing the Action Scheme of Promoting Inland Water Transport on Rivers including Yangtze River (2013-2020)*, it is required that governmental transportation departments at all levels shall improve the technical standard of carrying vessels. Furthermore, the use of LNG fuel on barges and the planning and construction of refueling stations and other supporting facilities shall be promoted.⁴³

Also, governmental transportation departments at all levels shall be committed to strengthen the promotion of scientific and technological achievements and cultivation of talents; based on the consideration of construction of inland water transport and management demands, to promote the promotion and application of technological achievements of inland water transport and improve the overall technology level of the industry, by means of starting up science and technology demonstration projects, compiling technical guidelines and revising relevant standards; by relying on the major construction projects on inland waterways, key scientific research projects, national engineering research centers and industry R&D centers, to strengthen the cultivation of technological leaders and outstanding young talents so as to build a high-level group of science and technology.

2.4.5 Vessel standardization on inland water

Compared with the previous incentive measures, which has only limited detailed statutory support, the incentive measures on vessel standardization are supported by special policies and legislations.

National Implementing Plan of Promoting Ship-Class Standardization on Inland Water during the 12th Five-Year Plan was formulated by the Ministry of Transport and the Ministry of Finance in conjunction with the people's government of more than ten provinces, and was published on 11 August 2013.

The very detailed *Measures on Subsidy on Ship-Class Standardization on Inland Water* (hereafter the *Measures*) were promulgated by the Ministry of Finance and the Ministry of Transport on 9 April 2014. Soon after on 13 August 2014, the Hunan Provincial Department of Transport and the Department of Finance issued the *Notice on Promoting the Implementation of Ship-Class Standardization on Inland Water in Hunan Province*, for the purpose of advancing the *Measures* in Hunan Province.

The application of the *Measures* consists of two horizontal lines, one vertical line, two waterway networks and 18 rivers including the Xiang River. According to the *Measures*, the subsidy funds are granted during the period from 01 October 2013 to 31 December 2015. For ships which are under construction until 13 December 2015, their date to be paid can be extended to 31 December 2017 if the project examined and verified by the authorized department of transportation and ship inspection institutions and then summarized and reported to financial department by department of transportation.

⁴³ For more information on the motives and the use of LNG-powered vessels in IWT in China, see <http://www.davidpublisher.org/Public/uploads/Contribute/5656bb454a18c.pdf> (accessed 27 Jan 16)

All ship owners who dismantle and rebuild their ships and all the water transport operators who build new model ships can apply for such subsidiary funds, exclusive of the dismantling and rebuilding of passenger ferryboat used in villages and towns.

There are five steps for the ship owners to obtain the subsidiary funds. First of all, applicants shall submit materials to the competent authorities. Generally, the owners of ship and water transport operators who apply for subsidiary funds should fill in an *Application for the Subsidy Funded by Government for Ship Dismantling and Rebuilding* or an *Application for Inland Model Ship Building* and apply to the authorized department of transportation and financial department at municipal (district, the same below) level together with Business Certificate for Water Transport Operation, Business License (ID, if the owner of ship is natural person), Ship Dismantling and Rebuilding Certificate or Technical Proposal for Building New Ships, and other related materials. Authorized department of transportation and financial department at municipal level are obliged to respond within ten (10) working days. However, for water transport operator who apply for the subsidy funds for building new LNG driven model ship and high energy efficient model ship, ship owners should apply for such subsidy funds after undergoing a technical evaluation in accordance with Measures for the Technical Evaluation and Recognition of Model Ships on Inland Rivers and being recognized as qualified, and at the same time, they should submit corresponding evaluation conclusion.

Secondly, applicants shall conclude a Subsidy Agreement specifying the dismantling, rebuilding and building method, time and place, subsidy standard, payment method, time limit, liability for breach of contract and so on with related authorities after the application being approved by authorized department of transportation and financial department at provincial level. It is related authorities' duty to notify information such as ship list, owners of ship (i.e. the applicant), time and place the ships are planned to be dismantled, rebuilt or built to the maritime bureau of the place where the ships are registered. If no clauses concerning payment method and time limit can be found in the model contract, the applicant may, in accordance with Article 24 Section 1 of the *Measures*, make relevant agreement with competent organs in a formal contract.

Thirdly, the whole process of construction shall be inspected, supervised and examined by the related authorities. Specifically, before construction, relevant department of transportation at municipal level should designate 1-2 staff with the local maritime administration department to supervise the dismantling and rebuilding on site, measuring the vessel and making records. In the process of building a new vessel, the current operation procedures prepared by ship inspection department should be followed and photos should be taken. Relevant administrative departments should file all the materials, certificates, photos and other materials concerning dismantling, rebuilding and building of such ships. After construction, relevant authorized department at municipal level should designate 1-2 staff with the local maritime administrative department to conduct acceptance on site and compile a *Ship Dismantling and Rebuilding Completion Report* (or *Ship Building Completion Report*).

Fourthly, applicants shall submit all relevant materials to competent authorities. In the Measures, no express definition is given on the mentioned "relevant materials". Hence, the applicants are suggested to inquire about the content of such materials from competent department before Step 3 and collect such materials in time during Step 3. In cases concerning the construction of new ships, further documentation is required. This includes the Application

for Building Inland Model Ship, the Ship Inspection Certificate, the Ship Ownership Certificate, the Ship Operation Certificate and the Application for the Subsidy Funded by Government for Building Inland Model Ship. Where LNG driven model ships and high energy efficient model ships are built, evaluation conclusion as required by Technical Evaluation and Recognition for Model Ships on Inland Rivers should also be submitted.

The last issue is about payment. The financial departments at municipal level should pay subsidy funds in time, the payment of which shall be enforced in accordance with relevant provisions of national treasury management system. Since the Subsidy Agreement is concluded before the promulgation of the Measures, the payment method and time limit can be defined by referring to relevant provisions of national treasury management system in advance. Hence, competent authorities should not easily use relevant provisions of national treasury management system to exempt themselves from relevant liabilities for breach of contract.

2.4.6 Traffic control of inland water transport

In the *Implementation Measures on Regulation of the People's Republic of China on the Administration of Navigable Waterways in Hunan Province* it is required that the administrative body of water gate and ship lock shall strengthen the management of water gates and ship locks to ensure their good function. Vessels that pass the water gate or ship lock shall obey the command by the administrative body.

The *Implementation Measures on Water Law of the People's Republic of China in Hunan Province* required that the construction of projects shall not affect the steady flow of river, or block the discharge of flood, and threaten the safety of project facilities such as structures that protect the slope, shore and dykes, and that pilot and assist navigation, and carry out hydrology monitoring, and shall not silt up any rivers, lakes, reservoirs and man-made channels. To those inevitable situations, the construction entity shall take remedial measures. In case losses are incurred, the construction entities shall make compensations in according to laws.

Additionally, before the settlement of disputes on waters, without agreement between the parties concerned or approval of the same higher level of people's government, no party may unilaterally change the current water situation by building structures that drain, block, collect or detain (store) the water within 5 km of the location of water dispute which happens at the borderline of administrative regions at or above county level, or within 3 km of the location of water dispute which happens at the borderline of administrative regions at or above township level.

According to the *Regulations on Xiang River Protection of Hunan Province* issued by the provincial Department of Water Resource of Hunan Province in 2013, the competent transport administrative department under the People's Government at or above county level shall strengthen the maintenance of Xiang River waterways so as to guarantee clear channels. No entity or individual may occupy or damage the navigable channel or navigation facilities. When Xiang River waterways are blocked, the waterway administration body shall take measures to repair the waterway in a timely manner. The entity which constructs or operates within the navigable waters of Xiang River, upon the completion of construction or operation, shall clear

the residues in a timely manner, and shall be subject to the waterway administration body for check and acceptance.

The owners of ship locks on the high-class section of Xiang River waterways shall, in according to the state standard or the industry standard of transportation, maintain the normal function of ship locks to guarantee safety and efficiency of passage through ship locks. A joint scheduling mechanism for ship locks in complexes shall be established on Xiang River. Such mechanism shall comply with the unified scheduling of flood prevention and drought relief on Xiang River.

As for the incentive measures on administrative control over inland water transport, a relatively complete supporting system of policies and legislation has been introduced. However, as to whether it is possible to solve the problems which occur during the implementation of these policies and legislation by means of making reversion to relative legislation, further investigation into the situation is needed.

2.4.7 Summary on incentives and first conclusions from the Chinese example

Summarizing the description of the existing regulations on the six incentive areas it can be stated that a full set of incentives are in place and are defined by relevant regulations for four incentive areas.

Table 6: Summary of incentive measures for IWT in Hunan Province

Incentive Name	Kinds of Incentive	Max Co-financing	Applicant	Relevant authority	Requirements	Fund Source
Barge Standardization	Co-financing of modern demonstration vessels	(1) CNY 630,000 – CNY 1,400,000 For LNG depending on the total power of engine and date of completion; (2) CNY 300 per gross ton multiplied by ship-type coefficient for HEE (Higher Energy Efficiency) vessels	Ship owner	HWTAB	Specifications of newly-built vessels required by certain regulations	The Ministry
Inland vessel technology innovation	Co-financing of reconstructing or dismantling unqualified vessels	(1) CNY 1,000 per ton multiplied by the vessel-age coefficient and the vessel-type coefficient for vessel dismantling (2) CNY 600 per gross ton for the reconstruction of unqualified single-hull vessels	Ship owner	HWTAB	Un-qualified vessels banned to sail by certain regulations	60% from Ministry, 40% from Provincial government
Waste Collection	Co-financing of reconstruction	Up to 100% subject to a cap (CNY 75,000 for cargo vessel)	Ship owner	HWTAB	Installation of sewage tank and sewage treatment unit	60% from Ministry, 40% from Provincial government
Set-up of IWT-related enterprises	corporate income tax relief	Fixed 15%	Logistic company operated in ports	Tax Bureau	Qualified as Hi-tech-related company	
Modal shift from road transport to waterway transport	No specific incentive measures for individual players identified					
Traffic control and navigation management						

Note: Traffic control and navigation management system: AIS and RIS system are all under construction. There is a draft regulation on this area. Deployment of base stations of AIS system has been completed in Hunan Province.

Exchange rate Chinese Yuan/Renminbi (CNY): Indian Rupee (Rs) 1 CNY : 10,2 Rs

Source: Consultants

The overview of the Chinese incentive and development programs to initiate and support IWT indicates the wide range of instruments, which are deemed to be necessary for a mature transport industry and infrastructure. It also indicates the engagement of the national ministries when it comes to rules and regulations. All in all, the programs presented above can constitute a viable tool box for the development of IWT and its promotion as an environmentally friendly mode of cargo transport. However, concerning the adaptability of these actions, disparities in the level of development of the respective IWT markets should be taken into account. Furthermore, differences in the political and institutional frameworks might have an effect on the direct transferability and feasibility of certain policies.

As the Indian IWT transport market is currently in a less mature stage, the question on the quality of infrastructure needs to be solved primarily prior discussing similar instruments which are applied in more developed IWT markets and infrastructures. However, based on the policy examples presented above, it should be noticed that comparatively easy application and verification processes are favorable when it comes to public co-financing of infrastructures and vessels. The precise development of a viable Indian IWT incentive program shall be executed in the framework of the Strategy Report.

3 Regional Demand

3.1 The NW-1 hinterland

Each national waterway has its own well defined area of influence. Although, all the declared waterway systems cannot be joined to form a national waterway grid, only some of the waterways can be connected i.e. NW-1 can be connected to NW-2 and NW-6 using protocol route through Bangladesh. Similarly, NW-5 that extends up to Paradip Port can also be joined in the National Waterway grid through backwaters of Hooghly and Hilly tidal canal. In the current exercise, areas on either side of the waterway systems which are likely to be affected (primary hinterland) by the proposed IWT services are considered. Because of the limited scope, secondary and tertiary catchment areas of the waterways are kept beyond the purview of the current study. In view of this, civil districts located on either banks of the river are considered as the relevant traffic regions. National Waterway 1, Ganges-Bhagirathi– Hooghly river system passes through the states of Uttar Pradesh, Bihar, Jharkhand and West Bengal, a distance of about 1,620 km, serving nearly 42 traffic regions, between Allahabad and Haldia (Sagar). Major ports such as Haldia and Kolkata and important cities like Kolkata, Patna, Varanasi and Allahabad fall under its primary hinterland. The river system serves richly endowed natural reserve areas as well as a large number of industrial units comprising thermal power plants, iron & steel plant, sugar mills, cement industry, small scale industries etc. The Consultants defined the following four sectors according to the market surveys which were centered around four future multi-modal terminals (for a list of the market survey producer interviews see *Annex 1* and of road-side interviews see *Annex 2*).

3.1.1 Haldia-Farakka sector

Particularities of the survey area (see below maps/figures) are as follows:

3.1.1.1 Zone 1: Kolkata-Howrah

Zone 1 contains the head offices of most of the companies (producer and users), is well connected through multi-modal transportation, and has the high density of population. The Hooghly River makes up the NW-1 within this zone. Zone 1 also is the area where the future Kolkata Garden Reach Terminal (GRT) is planned.

Kolkata has four long-distance railway stations, located at Howrah (the largest railway complex in India), Sealdah, Chitpur and Shalimar, which connect Kolkata by rail to most cities in West Bengal and to other major cities in India. Srijan Industrial Logistic Park in Howrah is located on NH6 (via this highway it offers fast access to Mumbai and Central India) in close proximity (13.3 km) to NH2 – the Golden Quadrilateral [GQ] connecting to Delhi and North India. The Park's location is also at the first leg of the GO to Chennai and South India. It connects to Kolkata (10.2 km) by the Kona Expressway NH117 and Vidyasagar Setu (11.7 km) Kolkata serves as the headquarters of three out of seventeen railway zones of the Indian Railways (IR) regional divisions - Kolkata Metro Railways, Eastern Railway and South-Eastern Railway. The city also has rail and road connectivity with Dhaka, capital of Bangladesh. The site for the future Kolkata GRT is located in this zone.

Figure 8: Demarcation of Zone 1 (Kolkata-Howrah and vicinity) and Zone 2 (Haldia and vicinity)



Source: Consultants' Market Survey preparation, July 2015

Dankuni is a fast-growing industrial township north of Howrah. The town is well-reachable by road or trains from both Howrah Station and Sealdah Station. Dankuni Junction rail station is 15 km from Howrah Station. The "Heart of Dankuni" is Dankuni Railway Station. The nearest airport is the Netaji Subhas Chandra Bose International Airport located at Dum Dum, 20 km from Dankuni. Major industries like "Mother Dairy", "Coca Cola", "Dankuni Coal Complex Ltd", "Food Corporation of India", biscuit company "Anmol Biscuits Ltd." and many other have been established. The town has witnessed great changes and developments in the recent years. It is progressing very fast due to the growing industries and manufacturing units. Both NH2 and NH6 terminate at Dankuni. Other major arteries meeting at Dankuni are Belghoria Expressway connecting to NH 4 and the Dankuni-Memari Delhi Road. Dankuni railway station is located on the Howrah-Bardhaman chord which is part of the Kolkata Suburban Railway system. Already, there is a growing presence of freight and wagon movements around Dankuni Railway Station, which is important as it connects Eastern Railway with South Eastern Railway with a link line. Dankuni has a fast-growing freight yard, where goods traffic is moved, sorted, and packed to deliver at other destinations. In the future, Dankuni will play a significant role because it will be the endpoint of the LudhianaDankuni leg of the EDFC that is being built by Indian Railways. Traffic, especially that of freight, will continue to grow and will positively impact the railways.

3.1.1.2 Zone 2: Haldia

Zone 2 contains many edible-oil, crude-oil and chemical industries. Due to the existence of the Haldia Dock Complex, the area is rich with shipping activities, terminals and warehousing.

Within Zone 2 lies the mouth of the Hooghly River and thus the final downstream part of the NW-1 down to Sagar Island. Haldia MMT constitutes the future major inland-shipping center of this zone. Haldia is connected to Kolkata by both bus and train. Haldia is a terminal railway station on the Panskura-Haldia branch line and is located in Purba Medinipur district. It serves the Haldia industrial area. The Howrah-Kharagpur line was opened in 1900. The Panskura-Durgachak line was opened in 1968, at a time when Haldia Port was being constructed. It was subsequently extended to Haldia. The Howrah-Kharagpur line was electrified in 1967-69. The Panskura-Haldia line was electrified in 1974-76. Indian Railways

propose to lay a new line connecting Sealdah and Haldia, with the distance being shorter by 70 km than the Howrah-Haldia track.

The site for the future Haldia Multi-modal Terminal (MMT) is located in this zone.

Figure 9: : Haldia Multi-Modal Terminal at present



Source: Consultants' site visit, June 2015

3.1.1.3 Zone 3: Durgapur-Raniganj-Burdwan

Zone 3 comprises a multitude of steel, cement/concrete and agro industries. These industries hold a huge potential in the production and supply of commodities.

Figure 10 Demarcation of Zone 3 (Durgapur-Raniganj-Burdwan and vicinity)



Source: Consultants' Market Survey preparation, July 2015

The NW-1 flows through the very east of Zone 3 with the Hooghly River in a rather peripheral situation, as it is the Damodar River which crosses the center of this zone. Along this river lies Durgapur, being an important city in terms of both commercial and industrial establishments is connected to almost all major places of Bengal. The important high-speed railway track connects Kolkata with Durgapur (distance 158 km) and passes on to Delhi. The main railway station is Durgapur railway station. Andal Junction is the main junction of the city. It is located at Andal, a western suburb of Durgapur, 15 km from Durgapur City Centre. The Andal-Sainthia branch line of the Eastern Railway Zone originates from this station and terminates at Sainthia on the Sahibganj loop line. Durgapur is well connected via roads. It is the preferred gateway to the districts of Bankura, Birbhum and Purulia of the Rarh Region, which has underdeveloped transportation infrastructure. NH2 and SH9 pass through the city.

The Grand Trunk Road (NH2) virtually bifurcates the area. This historically important arterial connector has now been widened into 2+2-lane highway as part of the Golden Quadrilateral project. Another wide road takes off from Darjeeling Morh near Panagarh for North Bengal. It also links Santiniketan to the Grand Trunk Road. The Durgapur Expressway, linking Dankuni with Memari on the Grand Trunk Road, allows fast communication between Kolkata and Durgapur (distance 170 km), where one can maintain cruising speeds of 80–120 km/h. Panagarh-Morgram Highway originates from Panagarh, a suburb of Durgapur, and joins NH 60 near Dubrajpur; this makes Durgapur a major road junction and an important destination for transportation toward North Bengal and North East India. NH 60 passes through Raniganj and heads away towards Orissa. It happens to be one of the very few cities that have an Asian Highway (AH1 linking Japan with Turkey) passing directly through the city jurisdiction. SH 9 joins with NH 60 and connects Durgapur with Orissa and South India.

3.1.1.4 Zone 4: Rampurhat-Nalhati-Pakur-Berhampore

Zone 4 is the area of the Hooghly River immediately downstream of the Farakka Barrage. In this zone, the Farakka lock and channel set the northern upstream limit of a presently rather easily navigable NW-1. To the west of the NW-1, this zone is home to many aggregates, sand, coal and agro industries. These industries have a very big potential for the supply of the booming construction business.

Figure 11: Demarcation of Zone 4 (Rampurhat-Nalhati-Pakur-Berhampore and vicinity)



Source: Consultants' Market Survey preparation, July 2015

3.1.1.5 Zone 5: Indo-Bangladesh Protocol Route

Zone 5 constitutes the area covered by that part of the Indo-Bangladesh Protocol Route (IBPR) which is covered by commodities being transported on that waterway. The Consultants' market survey identified commodities being shipped to Narayangunj (south of Dhaka) and further upstream to Ashuganj which constitutes a bridgehead into India's northeastern state of Tripura.

Figure 12: Demarcation of Zone 5 (Indo-Bangladesh Protocol Route)



Source: Consultants' Market Survey preparation, October 2015

3.1.2 Farakka-Munger sector

The influence area applicable to the proposed Sahibganj MMT has been defined by keeping in view the major origins and destinations of commodities identified during the reconnaissance survey. Sahibganj and Sakrigali being an abode to many stone chip industries, this area formed the core of the market research survey for the proposed Sahibganj MMT. Furthermore, major loading points of railway stations are surveyed to ascertain the amount of loading happened in the immediate preceding year 2014-15. The influence region along with the core area which lies in close vicinity to the NW-1 is shown in overleaf *Figure 14*.

Figure 13: Influence and core region-Sahibganj

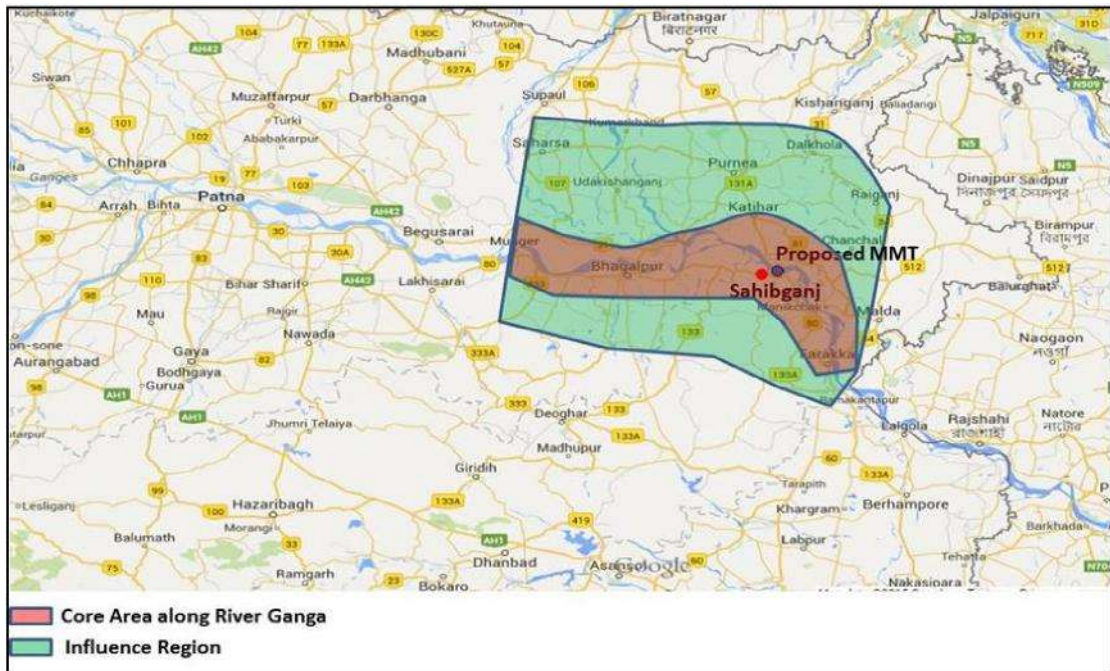

Source: Consultants' Market Survey preparation, August 2015

Major loading points of railways along with the major towns in the influence region are shown in Figure 15. Stone crushing industries and mines are located within a 5 km radius of the railway stations thus making it easier transporting the material by rail. Heavy work force is deployed along all the loading points to load the stone chips onto trucks at the mine and also at the railway siding. In general as a norm 8 hours of time is given by railways to load a full rake (one train load) at the railway siding.

Figure 14: Loading points in the influence region

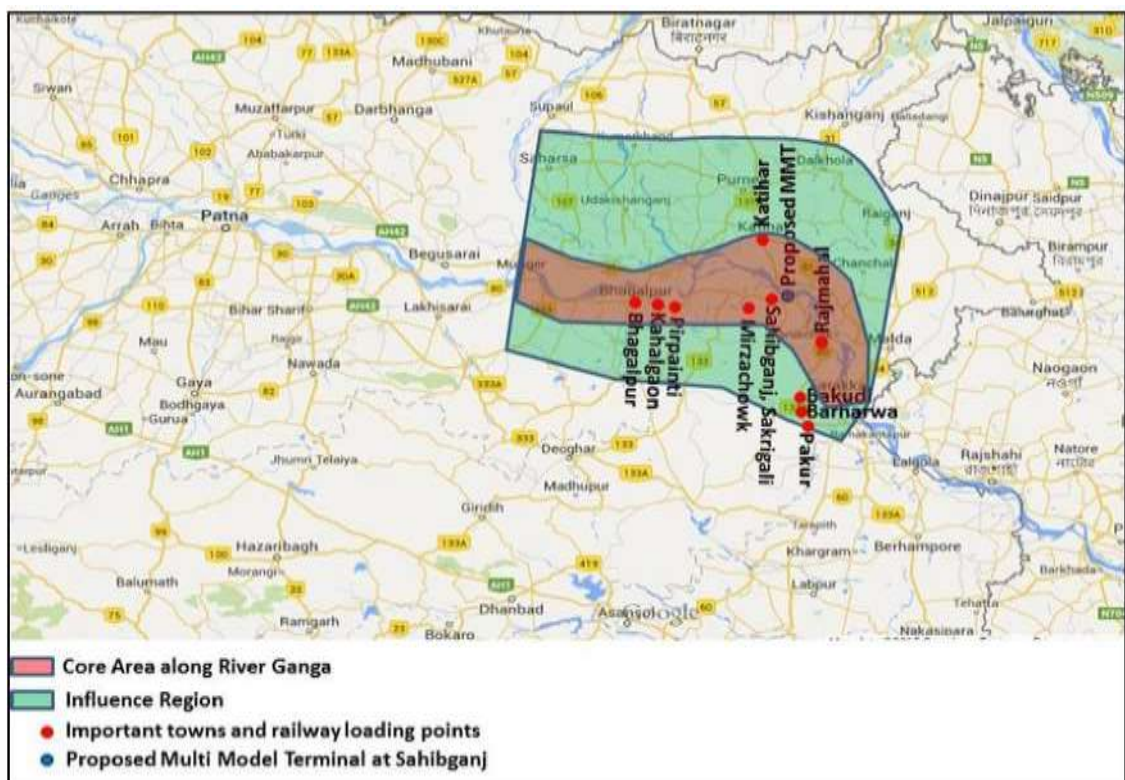

Source: Consultants' Market Survey preparation, August 2015

Opposite Farakka, on the eastern side of the NW-1, is Malda (called the "Gateway of North Bengal") which constitutes an important stepping stone into Bangladesh via N512 (Hili) and N508 (Bitur). North of Malda District, the N31, after crossing the Ganges River at Begusarai and leading through the important road knot of Purnea, runs through the "Chicken's Neck into the North-Eastern states of India. From Purnea, the N57 and N57A constitute an important road link with the border town of Biratnagar in the eastern region of Nepal.

3.1.3 Munger-Ballia sector

The survey commenced during the last week of July and covered a total area within a 200 km radius around Patna.

Figure15: Survey area covered around Patna

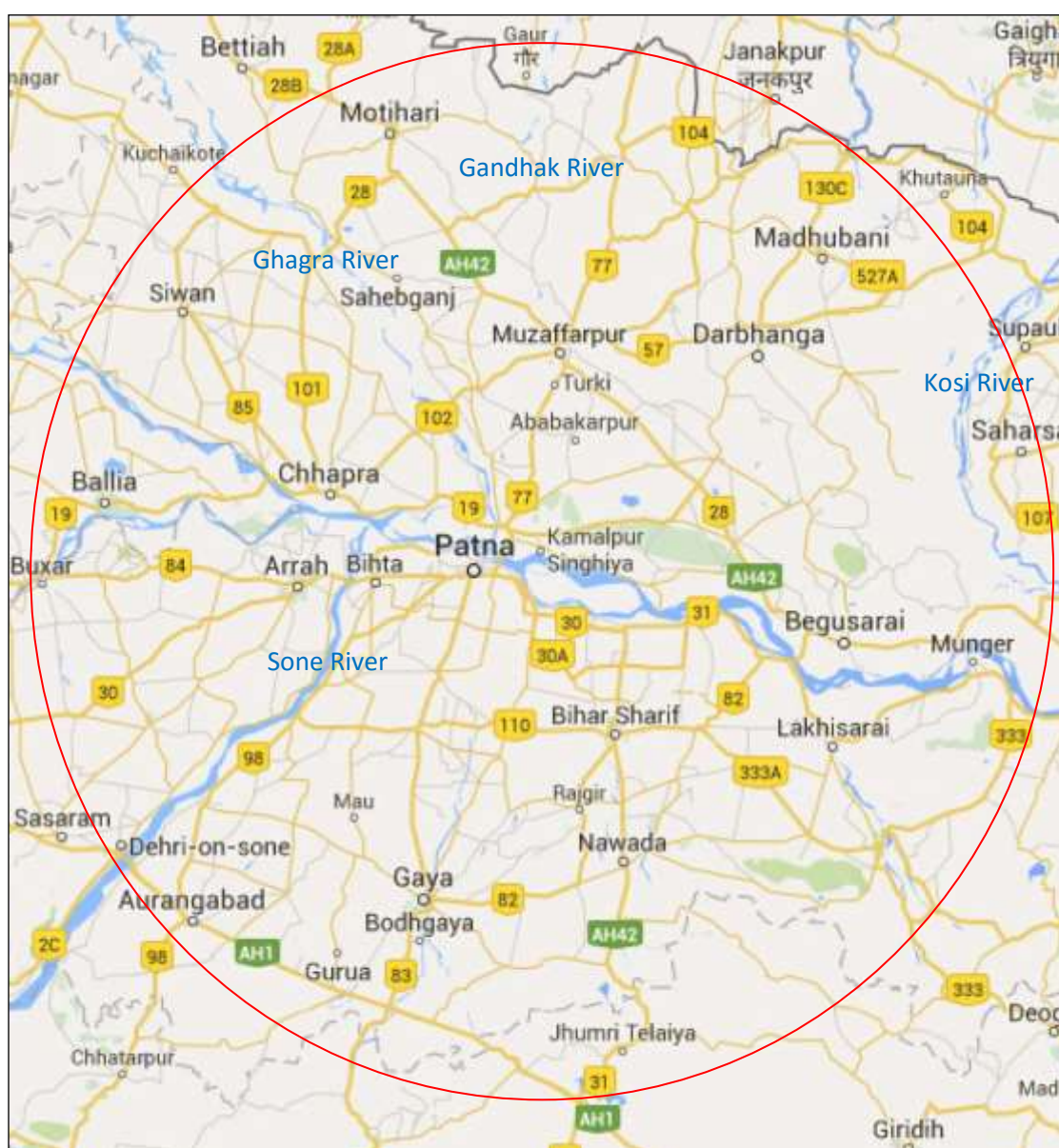

Source: Consultants' Market Survey preparation, July 2015

Major roads covered by this survey are the NH77 connecting to the Katmandu Valley / Nepal in the north and the NH2 (AH1) in the south.

3.1.3 Ballia-Allahabad sector

The market survey in this sector (limited by Ballia to the east and Allahabad to the west) was the last one to be commenced; however, it covered the widest area.

Figure16: Survey area covered within the Ballia-Allahabad sector

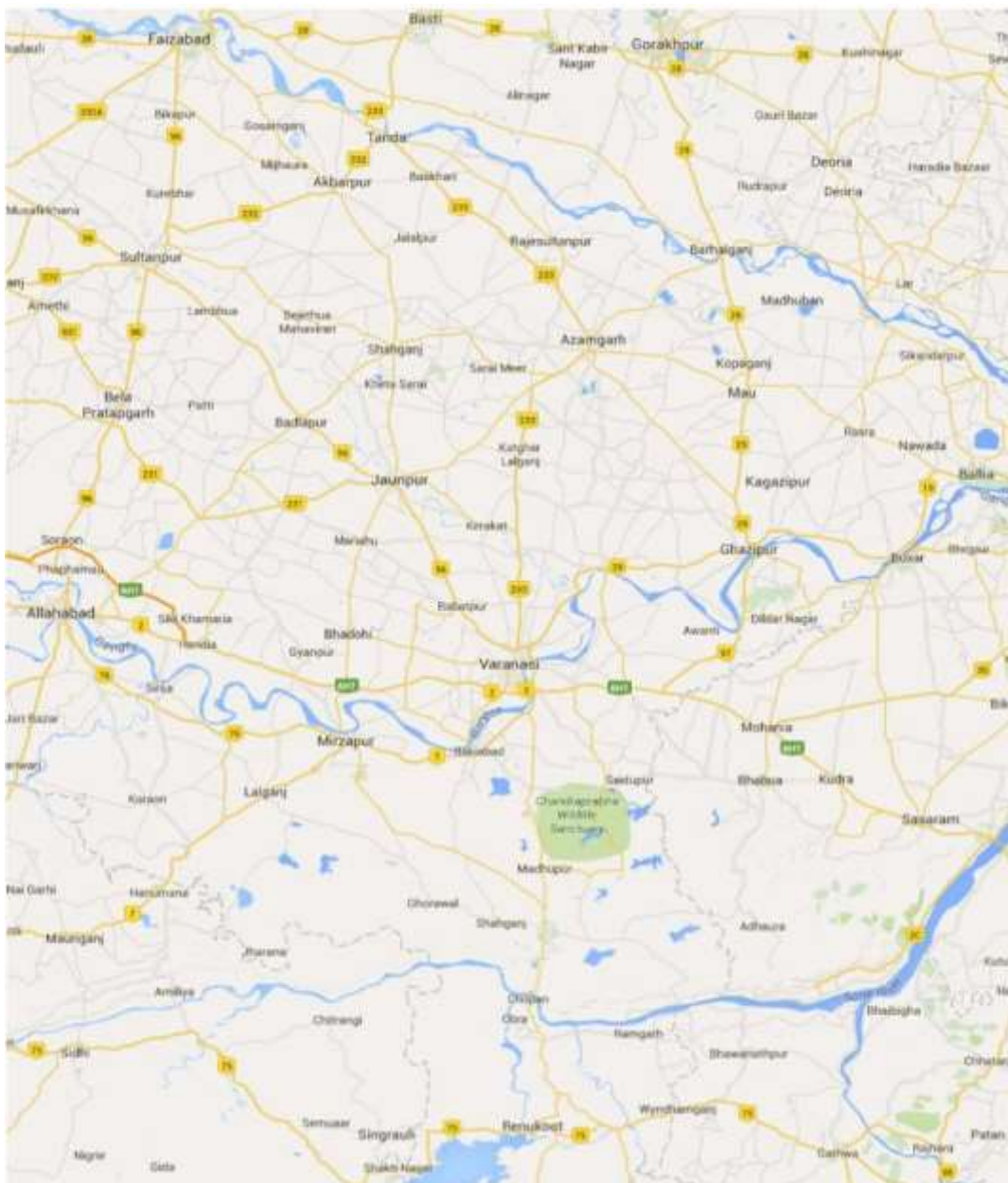

Source: Consultants' Market Survey preparation, July 2015

The survey area of this last sector is limited by two roads:

- To the north, NH28 connects to Lucknow, Barabanki, Faizabad, Basti and Gorakhpur;
- To the south, NH75 connects Jhansi (from Jaipur via NH11) with Ranchi (and onwards to Kolkata via NH33 and NH6).

The survey area is crossed by the Grand Trunk Road or National Highway Nr. 2 (NH 2) which forms the main transport spine which connects to Kolkata, Kanpur, Agra and Delhi. The market survey orientated itself along these major roads, from which the market interviewers swarmed out into the feeder roads.

3.2 Existing transport infrastructure

The NW-1 from Haldia (Sagar) to Allahabad (1,620 km) covers the states of Uttar Pradesh, Bihar, Jharkhand and West Bengal.

Potential traffic locations/regions, important commodities of interest for the NW-1, proposed nearest location on the river bank, and approximate distance between actual place of origin of the commodity and proposed IWT terminal identified in the study are given in below table.

Table 7: Traffic-generating regions and the nearest location

SN	Origin and Nature of Cargo	Nearest Terminal Location	Distance (Km)
1	Haldia (Coal)	Kolaghat	60
2	Sagarnidhi (Coal)	River front	18
3	Pakur (stone)	Pakur Terminal	12
4	Barauni (Fertilizer, POL)	Semaria	15
5	Semaria (Coal)	Barauni	15
6	Patna (coal)	Muzzafarpur	60
7	Patna (coal)	Nabinagar	150
8	Phulpur (Fertilizer)	Allahabad	50
9	Chunar (coal)	Rihand	135
10	Chunar (coal)	Vindychal/Singrauli	135
11	Chunar (coal)	Renusagar/Anpara	112
12	Chunar (coal)	Obra	67
13	Robertsganj/churk/Dala (Cement)	Chunar	67
14	Phulpur (Fertilizer)	Allahabad	50
15	Rewa (Cement)	Allahabad	119
16	Satna (Cement)	Allahabad	166
17	Sidhi (Cement)	Allahabad	211
18	Jagdishpur (Fertilizer)	Allahabad/Varanasi	138/187
19	Shahjahanpur (Fertilizer)	Allahabad/Varanasi	380/429
20	Raniganj Coalfield	Shantipur	205

Source: Planning Commission; Total Transport System Study

Figure 17: Location of IWAI facilities in relation to potential cargo locations

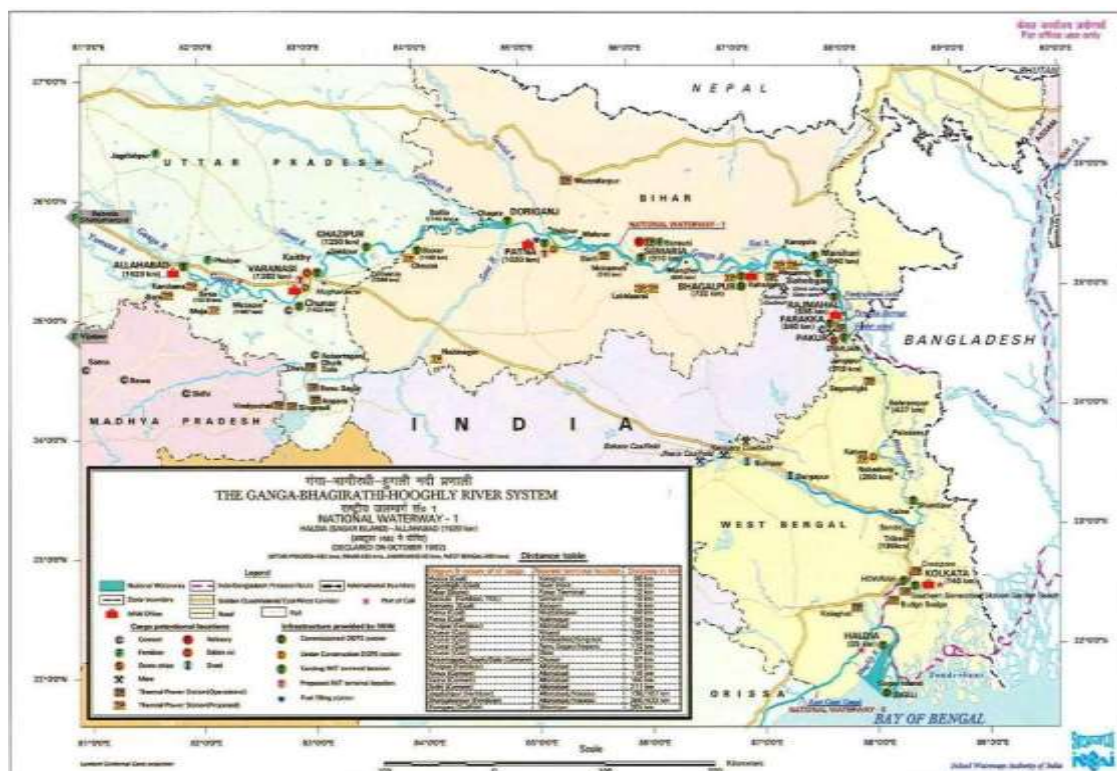

Source: IWAI

3.2.1 Terminals

Current capacities of existing terminals, such as: land area, berth size, type of terminal/jetty and broadly areas of command are given below in Table 9. As indicated by IWAI, on the entire route (between Allahabad and Haldia) of the 24 listed locations there are 18 IWT Terminals with floating jetties and 2 with fixed RCC Jetty.

3.2.1.1 Terminal capacities

Apart from the existing terminals listed below, IWAI has acquired large areas in Haldia, Sahibganj and Ramnagar (the Consultants’ *Jal Marg Vikas - Waterway Infrastructure Analysis Report* discusses these future terminals in detail).

Table 8: Size of existing terminals

SN	Name of Terminal	Land area	Berth Size	Type of terminal	District Served
1	Haldia	10,319 m ²	200 m	Floating	Haldia
2	Botanical Garden Jetty	996 m ²	50 m	Floating	Haora
3	BISN Jetty	11,607 m ²	100 m	Floating	Haldia Port
4	G.Rietty – 2 (Kolkata)	14,606 m	216 m	Fixed RCC Jetty	Kolkata
5	Shantipur	8,000 m ²	100 m	Floating	Shantipur
6	Katoya/Katwa	Pontoon on water front	30 m	Floating	Katwa/Pakur
7	Hazardwari	Pontoon on water front	30 m	Floating	Murshidabad,
8	Pakur (Putimari)	Owned by Farakka Barrage Project (FBP).		Fixed RCC Jetty	
9	Farakka	4,800 m ²	80 m	Floating + Fixed RCC Jetty	Farakka Side
10	Rajmahal	Pontoon on water front	35 m	Floating	Sahib Ganj, Jharkhand
11	Sahebganj	Pontoon on water front	35 m	Floating	Sahib Ganj, Jharkhand
12	Bateswarsthan	Pontoon on water front	35 m	Floating	Bhagal Pur , Bihar

13	Bhagalpur	10,000 m ³	35 m	Floating	Bhagal Pur , Bihar
14	Munger	13,766 m ³	35 m	Floating	Munger, Bihar
15	Semaria	Pontoon on water front	35 m	Floating	Semaria, Bihar, Arrah Berhampur
16	Barh	-	27 m	Floating	Barh, Bihar, Bihar Sharif
17	Fatuah	Triveni Ghat	-	-	Fatuha, Ranipur / Bihar
18	Patna (Gaighat)	13,118 m ³	46.6 m	Fixed RCC Jetty	Patna, Bihar
19	Pahleza	-	-	Pahleza Ghat Junction	Katmandu Valley / Nepal
20	Digha	-	-	FCL godowns	Patna, Bihar
21	Buxar	Pontoon on water front	35 m	Floating	Buxar, Bihar, Bhojpur, Bihar
22	Ghazipur	Pontoon on water front	35 m	Floating	Ghazipur , U.P., Ballia
23	Rajgat (Varanasi)	Pontoon on water front	35 m	Floating	Varanasi, U.P.
24	Allahabad	87,590 m ³	35 m	Floating	Allahabad, Mirzapur, Chaundali

Source: Planning Commission; Total Transport System Study

Based on traffic studies conducted by the Dutch Mission in 1983, the Total *Transport System Study* formed cargo groups with common handling & storage requirements. For example; coal, stone and fly ash are products that require same type of handling in terms of transshipment and storage and can therefore be handled at the same terminal. The same is applied for kerosene and POL. Raw jute, jute textile, food grains and sugars are cargoes that also have certain features in common. These types of cargoes are transported in sacks or bales and can be offloaded with same type of machinery. These cargoes are valuable and arrangements must be made for their storage in locked warehouses. Important commodities identified were: coal, fertilizers, stone, fly ash, POL+ kerosene, raw jute, jute textile, food grains, sugar, iron & steel products and salt.

3.2.1.2 Hinterland connectivity of existing terminals

Some of the existing IWT terminals have the distinct disadvantage that they are not directly linked with the Indian railway network.

Table 9: Nearest road and rail locations to NW-1

S.No	Name of NW-1 Terminal	Nearest NH/SH	Nearest Railhead	Gauge
1	Haldia	NH - 41	Haldia	BG
2	Katwa/Katoya	NH - 6	Katwa	BG
3	Hazardwari	SH	Murshidabad	BG
4	Behrampur	NH -34	Behrampur	BG
5	Farakka	NH -34	Farakka	BG
6	Sahebganj (Samdaghat)	NH - 80	Sahebganj	BG
7	Bhagalpur	NH-80	Bhagalpur	BG
8	Barh	NH - 30A	Barh	BG
9	Rajghat (Varanasi)	NH - 7	Mugalsarai	BG
10	G.R.Jetty-2 (Kolkata)	SH	Kidderpore	BG
11	Patna (Gaighat)	NH - 19	Gulzarbagh	BG

Source: Planning Commission; Total Transport System Study

The future multi-modal terminals in Haldia, Sahibganj and Ramnagar will remedy this disadvantage, as all three will be linked to all three modes: rail, road and inland waterway (see Annex 6 for the example of Sahibganj).

3.2.2 Facilities other than terminals

3.2.2.1 Storage infrastructure

The necessity for storage arises primarily because of lack of adjustment between the time and place of production of goods and time and place of their consumption. Warehouses play a vital role in the flow of goods from producers to consumers. It helps in combating annual and seasonal fluctuation in production and prices. Provision of facilities for food grains comes under the purview of the Department of Food and Public Distribution. In addition to storage of food grains, storage also includes industrial warehousing, custom-bounded warehouses, container freight stations, inland clearance depots and air cargo complexes.

Table 10: Number of food-grain storages, warehouses and container depots (as of 31 March 2012)

State	Food-grain storages (mt)	Warehouses (no.)	Container depots (no.)
Bihar	87,675	16	-
Jharkhand	19,300	3	-
Uttar Pradesh	680,503	48	7
West Bengal	164,160	37	2
Total India	5,264,854	467	37

Source: All India Electricity Statistics published by Central Electricity Authority, M/o Power

Setting the absolute numbers of the above table in relation to the area and population of the four riparian states, a picture of relative misdistribution becomes evident.

Table 11: Coverage of food-grain storages, warehouses and container depots (by area and population)

State	Food-grain storages		Warehouses		Container	
	(tons/'000k m ²)	(tons /head)	(no./'000km ²)	(no./head)	(no./'000km ²)	(no./head)
Bihar	930.7	844.6	0.17	0.15	-	-
Jharkhand	241.3	585.5	0.04	0.09	-	-
Uttar	2823.7	3409.7	0.20	0.24	0.03	0.04
West Bengal	1844.5	1797.1	0.42	0.41	0.02	0.02
India	1601.6	4350.4	0.14	0.39	0.01	0.03

Source: All India Electricity Statistics, Consultants' calculations

The state of Bihar, although a major agricultural producer area, is not well endowed with food-grain storages. Jharkhand, being a predominant mining state, would not require a dense network of food-grain storages and warehouses. In contrast, the two states of Uttar Pradesh and West Bengal are equipped similar to India as a whole.

3.2.2.2 Haldia-Farakka sector

Apart from terminals, following infrastructure exists along the surveyed NW-1 sector:

Table 12: Facilities (terminals, cold storages) identified in the Haldia-Farakka sector

Name of Facility	Type of Commodities handled	Quantity handled per annum	Origin/Supply chain	Destination / Supply Chain / Cost
T. T. Shed (Kolkata)	Fly Ash	80,69,262 tons per year (2014-15)	Durgapur, Kolaghat, Titagarh, Bandel (W.B.) / by road / Rs 1.30 per ton-km	Bangladesh / Barge / US\$ 15 / ton
Falta SEZ (S-24 Parganas)	Logs	60,000 tons per year	Burma, Indonesia, Papua New Guinea / by sea to Kolkata or trans-loading at Sagar Island / US\$ 110-120 per hopper-ton/ by barge from Falta Jetty to KPD/ Rs 400 per metric ton	West Bengal / Road
Hooghly District (total 9 nos cold storages) Baidyabati to Tarakeswar	Potatoes	12 MMT (capacity of each cold storage: 2,50,000 - 4,00,000 bags of 50 kg)	West Bengal - Hooghly District	All W.B. 60%, neighboring states (Bihar-Patna-Gaya, Allahabad, Orissa, Jharkhand, Assam, Andhra Pradesh) 40 % / by road / Rs 25 to 35 per bag

Source: Consultants' Market Survey July-October 2015

3.2.2.3 Farakka-Munger sector

Following infrastructure has been identified along this surveyed NW-1 sector:

Table 13: Facilities (terminals, cold storages) identified in the Farakka-Munger sector

Name of Facility	Type of Commodities handled	Quantity handled per annum	Origin/Supply chain	Destination / Supply Chain / Cost
LCT Facility	Ro-ro (stone chips) and public transportation	~0.1 MMT/year	Sakrigali/ Sahibganj	Manihari (Rs 1,300 for loaded truck and Rs 750 for empty truck)
Rajagopalachari	Ro-ro (stone chips only)	~600 tons a day	Sakrigali/ Sahibganj	Manihari (lump sum amount about Rs 6,000 for 40-ton truck)

Source: Consultants' Market Survey July-October 2015

The two facilities depicted above serve the stone-chips trade.

3.2.2.4 Munger-Ballia sector

Present terminal at Patna: Handling facilities plus IWAI office and NINI are located directly below the Gandhi Bridge. The handling facilities consist of

1. quay for normal water levels,
2. quay for flood-water levels, and
3. flood-proof transit shed.

Quay for normal water levels: The lower quay is about 60m long and 20m wide. It is connected through a wide and well-paved road-ramp to the street at the top banks.

Quay for flood-water levels: The upper ground quay is situated about 10 meters higher and is well secured.

Transit shed: The transit shed is at the level of the upper quay. It is used for short-term storage of cement and fertilizers. Dimensions are approximately 40m x 10m with a clear height of about 5m. Access is by two large roller doors (approximately 3m x 4m) on each side.

Figure 18: Existing Patna terminal



Source: Consultants' Market Survey July-October 2015

For cargo operation IWAI has available three mobile cranes of 75 tons (1) and 20 tons (2) capacity, which are also served by IWAI employees. Horizontal transport is the responsibility of the cargo owner.

Doriganj or Pahleza

IWAI is planning to establish a multi-modal terminal on the northern side of the Ganges River either at Doriganj 15 km upstream of the city of Patna or at Pahleza opposite of Patna. This terminal would mainly serve as traffic node for Nepal-bound cargo; the location has been chosen due to proximity to Birgunj in Nepal and onwards to the Katmandu Valley.

3.2.2.5 Ballia-Allahabad sector

Some of the existing private facilities in this last sector have been defunct for a longer period:

Table 14: Facilities (terminals, cold storages) identified in the Ballia-Allahabad sector

Function	Location	Capacity	Name	Designation	Remarks
Cold Storage			Sai Cold Storage		
Container	Bhadohi	60 trucks / day	Pradeep Kumar Singh Terminal Incharge	ICD Concor (Container Depot)	Train for Bombay stopped 6 months ago
			CWC		CWC closed for last 3 years
Cold Storage	Pratap	25,000 tons	Shahi Cold Storage	Potato	40 Km radius
Cold Storage	Pratap	4,000 tons	Pratap Cold Storage Chilibila	Potato	
Cold Storage	Sultanpur	6,000 tons	Mansa Cold Storage	Potato	

Source: Consultants' Market Survey July-October 2015

3.3 Special economic & industrial zones

With the Special Economic Zone Policy having been announced in 2000, the implementation of Special Economic Zones (SEZ) has become a focus of Indian national economic policy. SEZs are geographically bound areas that aim to attract foreign and domestic investments, promote new business settlements and foster economic growth by offering competitive infrastructural premises, simplified regulations and attractive financial incentives. Among the benefits offered to SEZs are duty-free procurement of goods for development, operation and maintenance, significant exemptions on income, central sales and service taxes as well as simplified procedures on external commercial borrowing.

A corresponding SEZ Act was passed by Parliament in 2005 with the objectives to generate additional economic activity, promote exports of goods and services, promote investments from domestic and foreign sources, create employment activities and develop infrastructure facilities. As of March 2015, a total number of about 200 exporting SEZ facilities were active nationwide.⁴⁴ Whereas India's early policy resulted in the approval of a relatively large number of small SEZs, more recent strategy adjustments indicate a change of thinking in favor of larger industrial zones. A corresponding policy on the development of National Investment and Manufacturing Zones (NIMZ) and industrial parks was unveiled in 2011.⁴⁵

As India's current economic policy supports the clustering of businesses and the generation of additional economic activity at designated zones, added demand for transport services on relations to and from such SEZ locations and industrial parks can be expected. When large volumes of cargo have to be transported, IWT could potentially offer economies-of-scale and operational advantages over other transport modes. The degree to which IWT will be able to commercialize these advantages and benefit from SEZ related cargo will however depend on geographical and infrastructural premises as well as the types of commodities manufactured.

⁴⁴ See <http://www.sezindia.nic.in/writereaddata/pdf/ListofoperationalSEZs.pdf> (accessed 12 Feb 16)

⁴⁵ See <http://www.ibef.org/download/SEZs-Role-in-Indian-Manufacturing-Growth.pdf> (accessed 12 Feb 16)

Figure 19: Location of special economic zones



Source: Maps of India

Concerning the economic geography, more and larger SEZs have been approved and notified in the southern parts of India than in the north. As the SEZs cover various industrial sectors, specific cargo needs vary. High-tech industries such as IT, hardware or pharmaceutical businesses currently account for a large proportion of the operational SEZs. Other priority areas for SEZ also include the textile and engineering sector. Within the greater catchment area of NW-1, SEZs can currently be found in the Kolkata region, in the Kanpur district and in the New Delhi/Noida area. Goods produced in these SEZs include IT equipment, textiles, handicrafts, leather and jewelry.

Table 16 gives information on most visible exporting SEZs in the NW-1 states of W.B. and U.P. As one can see, the existing SEZs differ strongly in size with a tendency towards small units. In means of the manufactured goods, one can detect that many high valued goods (especially in the sector of IT-goods) are produced in mentioned SEZs. Referring to the IWT

this is not a commodity, which is normally transported by this mode of transport. Furthermore, none of the SEZs mentioned above has direct access to navigable waterways.

Table 15: Exporting special economic zones in West Bengal and Uttar Pradesh (examples)

SEZ	Location	State	Goods	Size (ha)
Falta Special Economic Zone	Falta	W.B.	Multi-Product	280
M.L. Dalmiya & Co Ltd.	Kolkata	W.B.	IT	49
Bengal Gem and Jewelry Park Salt Lake Manikanchan	Kolkata	W.B.	Gem, Jewellery	16
WIPRO SEZ Salt Lake	Kolkata	W.B.	IT	5
Unitech Hi-tech Structures Ltd	Kolkata	W.B.	IT	10
Tata Consultancy Services Ltd	Kolkata	W.B.	IT	16
DLF Limited	Kolkata	W.B.	IT	10
Moradabad SEZ	Moradabad	U.P.	Handicrafts	421
HCL Techn.	Noida	U.P.	IT	17
Seaview Developers Ltd.	Noida	U.P.	IT	12
Aachvis Softech Pvt. Ltd.	Noida	U.P.	IT	10
Moser Baer	Greater Noida	U.P.	Non-conv. energy	12
WIPRO Ltd.	Greater Noida	U.P.	IT	20
NIIT Techn. Ltd. SEZ	Greater Noida	U.P.	IT	10
Ansal IT City and Parks Ltd.	Greater Noida	U.P.	IT	30
Arthal Infratech Pvt. Ltd.	Greater Noida	U.P.	IT	10
Arshiya Northern FTWZ Ltd.	Khurja	U.P.	IT	51

Source: Government of India, Chamber of Commerce (<http://www.sezindia.nic.in/about-osi.asp> Data as of 31 Mar 15)

With regard to the ongoing economic and industrial development in the NW-1 corridor, the implementation of further SEZs, new industrial areas and NIMZs could help bundling economic activities and promote local goods and businesses. Potential focus industries situated along the waterway include the textile, handicraft and wood processing sectors as well as agricultural and building-material businesses. Given the necessary infrastructural premises, IWT could provide an effective mode to transport-corresponding goods.

Compared to IWT, however, transportation by rail or road usually not only constitutes the faster mode of transport but also offers better area coverage, thus enabling direct door-to-door transport and minimizing handling costs that occur when pre- and onward carriage by other transport modes is necessary. In order to fully exploit the costs benefits offered by IWT it would therefore be desirable to locate new SEZ units or industrial zones at sites with direct access to navigable waterways as well as dedicated IWT terminals or jetties. Given the export focus of many SEZs, the use of IWT could then also help facilitating operational processing, simplifying customs clearances and speeding up transshipment handling at the often congested sea ports. Possible application cases for IWT promotion through industrial areas and SEZs will be discussed in the Consultants' *Part C Report*.

3.4 Facilities and infrastructure required to enhance modal shift

The aim of this section is to identify facilities and infrastructure required in general or at identified special economic zones (SEZs), depots, warehouses, container freight stations (CFSs) etc. in particular to contribute or enhance modal shift. The term "modal shift" describes the change of transport mode for cargo units. As this study focuses on the

augmentation of the NW-1 the shift of cargo transport from rail to IWT and from road to IWT is the shift of interest.

Among others, the following facilities and activities do support modal shift from road/rail to IWT:

- Adequate amount of storage space, both covered and open with modern mechanical handling facilities (particularly for container and bulk handling);
- Multi modal terminals with adequate facilities for handling all different commodities without disturbing each other;
- Ro-ro facilities for heavy lift / Over-Dimensional Cargo (ODC) and automobile cargo;
- Haldia: A Vessel Traffic Management System (VTMS) at Dadan Patra Bar near Mandarmoni;
- Haldia: Lease for 141 acres to various private and government organizations entailing an investment of around Rs 53.5 billion;
- Existence of industrial production units within the close proximity of the future Haldia MMT;
- Motivating users to set up their units on the water front;
- Financial incentives or subsidies to cover risk during set-up phase of certain supply chains involving the IWT sector;
- Haldia: Opportunity will open up only when the service is available at Haldia MMT. For some companies a MMT at Haldia would provide immense advantages for their commodities on the NW-1 as their O/D pairs lay exactly on NW-1 routes. A Haldia MMT will definitely give a boost to inland-water transportation which was largely untapped and underutilized despite its high growth potential. A ro-ro facility for automobiles (such as Maruti-Suzuki from Gurgaon), heavy lift and ODC cargo must be provided at the proposed Haldia MMT which will surely offer a lot of opportunities to meet the requirement for heavy lift / ODC transportation along the NW-1 and NW-2;
- Kolkata has four long-distance railway stations, located at Howrah (the largest railway complex in India), Sealdah, Chitpur and Shalimar, which connect Kolkata by rail to most cities in West Bengal and to other major cities in India. The city serves as the headquarters of three out of seventeen railway zones of the Indian Railways (IR) regional divisions: Kolkata Metro Railways, Eastern Railway and South-Eastern Railway. Kolkata also has rail and road connectivity with Dhaka, capital of Bangladesh;
- Good connectivity to hinterland infrastructure like Kolkata is close to Durgapur, a city which is the base for significant steel industries. The important high-speed railway track connects Kolkata with Durgapur (distance 158 km) and passes on to Delhi;
- Availability of infrastructure: Indian Farmers Fertilizer Corporation (IFFCO) has a plant project at Paradip, but the project (including a 120m jetty) has stopped due to legal issues. The Paradip factory is the largest of five more plants in Gujarat, U.P. and Orissa;

- Availability of barges and vessels: IFFCO is planning on using river-sea vessels (RSV) between Paradip and Haldia sea ports, from thereon using NW-1 to Bihar and U.P.;
- Identification of matching O-D-pairs coming up with a transport route providing suitable for the same barge/vessel in both directions: India's North is producing wheat which is needed in the South. Uttar Pradesh and Bihar are the largest agricultural regions. There are large cargo volumes generated to be transported south. In reverse, rice is available in India's South which is needed in the North. Kolkata region is well known for rice farming.

Figure20: Aspects enhancing modal shift from road/rail to IWT

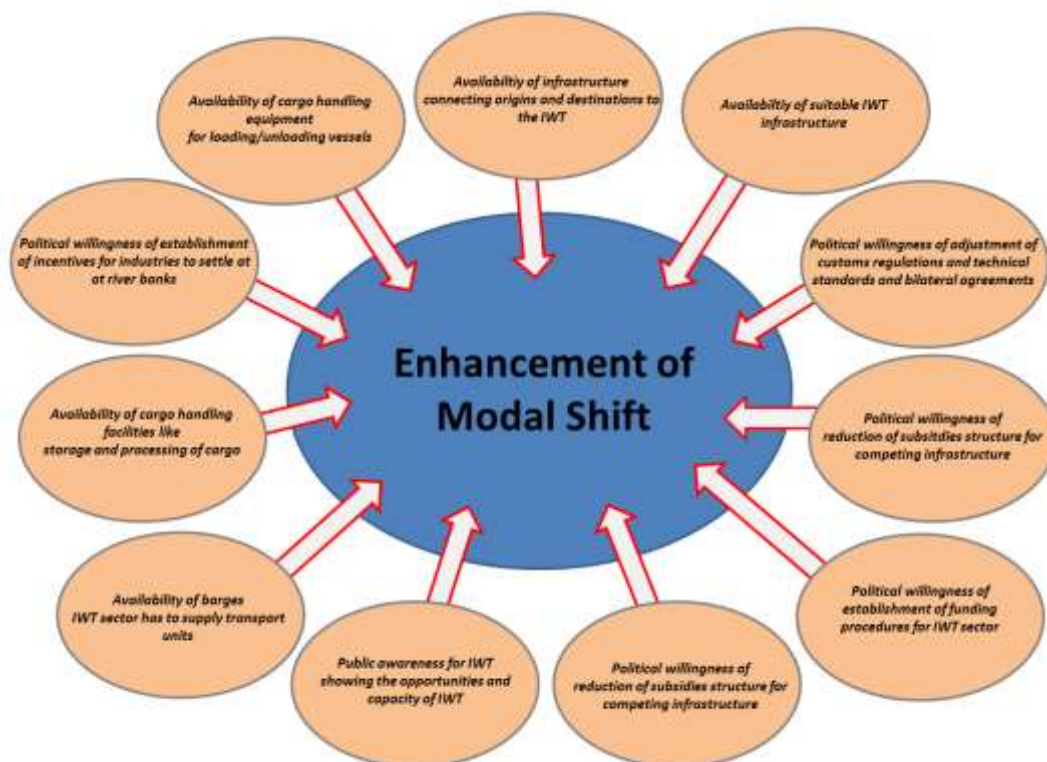

Source: Consultant's illustration

As rail is a direct competitor to IWT, almost each further investment in railway facilities potentially weakens the development of IWT.

India's Prime Minister (PM) and Bangladesh's PM agreed in June 2015 to strengthen their trading relationship by improvement of customs procedures as well as access to existing and new infrastructure (road, rail and water). This includes, among others, development of roads connecting Bangladesh to India's north eastern states and ports to facilitate more efficient and faster movement of cargo. Besides this, also the Coastal Shipping Agreement that has been signed by both nations is expected to boost the bilateral trade mainly by cutting down the transit times of cargo from Indian ports to Bangladesh. As there is currently no direct connection between Indian ports and the Bangladeshi Port of Chittagong for example the new agreement establishes a lower but pragmatic standard for a vessel known as the River Sea Vessel (RSV). The design of this vessel standard is already available. The RSV category has significantly lower construction and operation costs compared to the common ocean going vessels. The Prime Minister's Office (PMO) stated in August 2015 that the ports of Chittagong

and Mongla in Bangladesh as well as the ports of Haldia and Kolkata will represent the main periphery. Further locations are currently under examination to probably enhance the Indo-Bangla port network by additional appropriate and suitable cargo handling points. This development is also an advantage for the IWT on the NW-1 as Kolkata and Haldia represent the south eastern “gate” of the NW-1. If opportunities for onward-traffic (beyond NW-1) are pushed, supported and/or established on a political level the NW-1 itself can only derive benefits from this development

3.5 Eastern Dedicated Freight Corridor

The Eastern Dedicated Freight Corridor (EDFC) is a broad-gauge corridor under construction for an electrified railway covering a total distance of 1,839 km. Within the influence region of the NW-1, this corridor will have double line.

Figure 21 : Course and construction progress of EDFC

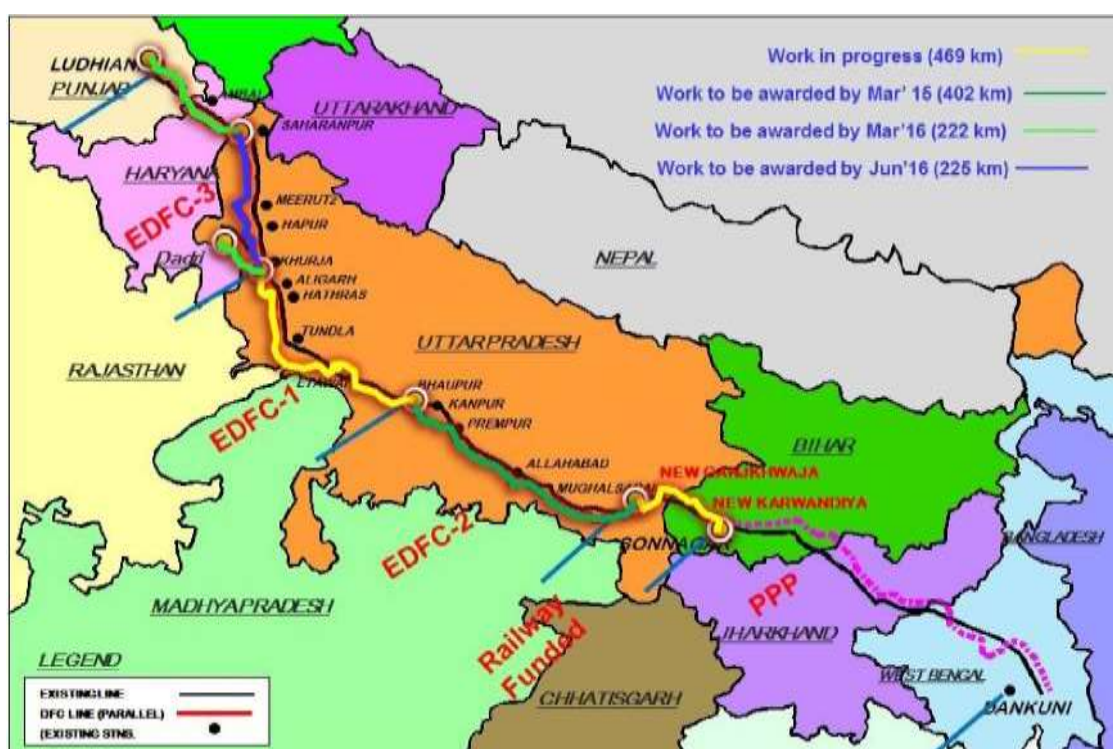

Source: http://dfccil.gov.in/dfccil_app/Eastern_Corridor.jsp (accessed on 18 Feb. 2016)

The EDFC is projected to cater to a number of traffic streams: coal for the power plants in the northern region of U.P., Delhi, Haryana, Punjab and parts of Rajasthan from the Eastern coal fields, finished steel, food grains, cement, fertilizers, lime stone from Rajasthan to steel plants in the east and general goods. A significant part of this increase would get diverted to the EDFC. As per the RITES project report, the traffic that would move on EDFC, excluding the base year traffic (2005-06), is projected in overleaf Table 16.

The total traffic in up-direction is projected to go up to 116 MMT in 2021-22. Similarly, in the down-direction, the traffic level has been projected to increase to 28 MMT in 2021-22. As a result, the incremental traffic since 2005-2006, works out to a staggering 91 MMT.

The EDFC will connect with the NW-1 at the later’s final upstream stretch at Allahabad and Ramnagar MMT (through a dedicated rail link from Mughal Saraj) and its downstream stretch at Dankuni Rail Junction (on the western site of the Hooghly River opposite Dum Dum).

Consequently, it will depend on mutually beneficial traffic-sharing agreements whether the EDFC will provide, from its western end, additional cargo volumes to the NW-1 influence region of Bihar and northern W.B. or draw traffic from potential through-going waterway voyages between Kolkata and Varanasi.

Table 16: Traffic projection on EDFC (MMT/year)

Direction/Commodity	2016-17	2021-22
UP Direction		
Power House coal	54.46	61.96
Public Coal	0.61	0.95
Steel	8.24	9.74
Others	1.61	2.96
Logistic Park	1.20	2.40
Sub-Total	66.12	78.01
Down Direction		
Fertilizer	0.23	0.42
Cement	0.78	1.52
Limestone for the Steel Plants	4.99	5.00
Salt	0.68	1.03
Others	1.61	2.96
Logistic Park	1.20	2.40
Sub-Total	9.48	13.32
Grand Total	75.60	91.33
Rites Report: Table 14.3. of Eastern Corridor PETS Report		

Source: http://dfccil.gov.in/dfccil_app/Eastern_Corridor.jsp (accessed on 18 Feb. 2016)

A Memorandum of Understanding (MoU) was signed between IWAI and the Dedicated Freight Corridor Corporation of India (DFCCIL) on 19 March 2015 for creation of logistic hubs with rail connectivity at Varanasi and other places on national waterways. The joint development of state-of-the-art logistics hubs at Varanasi and other places would lead to convergence of inland waterways with rail and road connectivity. This would provide a seamless, efficient and cost effective cargo transportation solution.

3.6 Existing transport demand

Cargo that has a potential to pass through the region and to be handled at the future multi-modal terminals can be broken down into the following seven commodity groups (containing the major commodities):

1. Thermal coal (imported high-calorie coal, domestic low-calorie coal), coking coal and pet coke;
2. Building materials (stone chips, cement, sand, gypsum, steel coils/wires/girders);
3. Agricultural inputs (fertilizer (urea), poultry feed, agro equipment);
4. Food grains and flour (wheat, corn, rice, flour);
5. Industrial inputs (steel/iron, manganese ore, spirits, fly ash, limestone, plastics, paper);
6. Consumer goods (motor bikes, cars, container loads); and
7. Over-dimensional cargo.

Following section gives a description of individual commodity producers and users, and of specific industries which could potentially use such commodities. Transport demand is expressed, wherever possible, in terms of concrete cargo volumes.

3.6.1 Haldia – Farakka sector

3.6.1.1 Thermal coal

A 1,000 megawatt (MW) thermal power plant needs 5 MMT per annum of coal and 100 cubic seconds (cusecs) water. Due to its high water requirement, the plant ought to be located along large water bodies. India's coal mines are located mainly in seven states: Jharkhand and West Bengal in the east, Odisha to the south, Madhya Pradesh and Chhattisgarh in the central region, Maharashtra in the west and the newly-created state of Telengana in the south (see below *Figure 23*). However, coal users are located in almost all states except in the north-east and India's three most northerly states where hydropower prevails. As a result, power plants to the north and west are served by long-distance rail routes from mines in the eastern and central regions. Imported coal is also carried to power producers over long distances from ports in western India to the north. Power plants in coal mining states have to import coal, owing to an administrative system of long-term contracts between mines and coal consumers in other states, including those along the coast. Imported coal is being shipped to, among others, ports at Visakhapatnam, Paradip and Haldia, as closest ones to the NW-1.

Figure 22: Coal fields and coal-fired thermal power plants

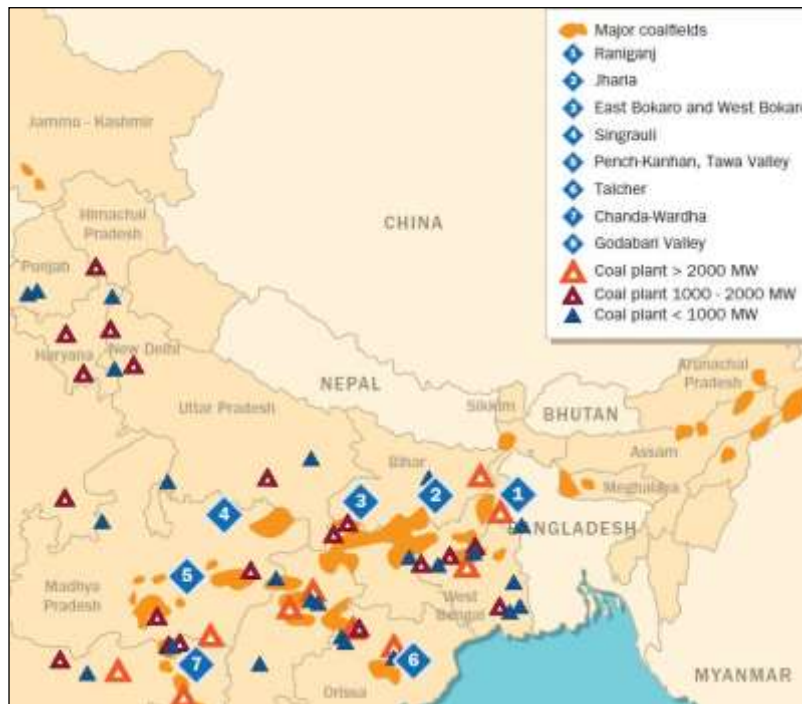

Source: EIA

Eleven existing thermal power plants on either side of the river between Haldia and Allahabad and 10 more upcoming power projects have boosted the prospect of the NW-1 like never before for transporting imported coal to power stations. In the next five to eight years total installed capacity will reach well over 15,000 MW. The total requirement of coal is estimated to be around 70 MMT per annum. Around 14 MMT of imported coal would need to be carried to these power stations from Haldia. National Thermal Power Corporation Ltd (NTPC)'s power plants at Farakka and Kahalgaon require imported coal amounting to more than 5 MMT per annum which are brought through Paradip and Haldia ports. But due to capacity constraints of railways, these power plants regularly face shortage of coal.

Further, due to low depth available at Haldia port, bigger ocean going vessels cannot come there, due to which 70% of imported coal is received at Paradip Port and from there it is transported by railways. Both these power plants are located along the NW-1 quite close to the river bank. All the existing and proposed thermal power plants along the NW-1 are potential shippers for IWT if IWAI can provide assured channels of 2.5 m depth or more. Up to 25 MMT of coal could be transported by IWT mode on NW-1 every year. The resource areas for domestic low-calorie coal are in larger distance to the two multi-modal terminals in the Haldia-Farakka sector. As the nearest MMT is far away, they could be shipped only through terminals in other survey areas.

3.6.1.2 Fly ash

With average ash content of 25% in coal, total production is estimated to be around 17.5 MMT per annum. With the use of fly ash in the manufacturing of cement and in the construction of roads, the NW-1 could be utilized for evacuation of fly ash from power plants on its banks. Thereafter, the fly ash moved to respective destinations through multi-modal transport systems. One prominent example is presented as OD-pair in the following:

The Consultants have identified almost 270,000 tons of fly ash transported by barge from Kolaghat (W.B.) to Narayanganj (Bangladesh) over an 820 km distance, a voyage which takes almost five days. This OD-pair is analyzed further in *Chapter 5.3*.

Table 17: Feasible cargo OD-pair via Kolaghat – Fly ash

Origin	Destination	Transport Mode	Distance [km]	Travel Time Est. [days]	Volume 2014 [tons]
Kolaghat (W.B.)	Narayanganj (Bangla)	Barge	820	4.9	266,461

Source: Consultants' Market Survey, August-October 2015; calculations by Transport Model

3.6.1.3 Stone chips

The principal centers of production are Pakur (W.B.), Munger in Monghyr District (Bihar) and Chunnar in Mirzapur District (U.P.).

3.6.1.4 Cement

Cement factories are to be found in most states except the north-east. In the Haldia-Farakka region, ACC Ltd operates two cement factories in 50 km distance from each other: 1. *Damodar Cement Works* in Madhukunda of Purulia District (W.B.), and 2. *Sindri Cement* in Dhanbad District (Jharkhand). As the largest cement and concrete producer in India, ACC Ltd constitutes one of the biggest customers of the domestic coal industry, and is a considerable user of the country's transport network services for inward and outward movement of materials and products.

3.6.1.5 Sand

While silica sand is used mainly for glass factories, normal sand is predominantly used for construction.

3.6.1.6 Iron & steel

Steel plants are mostly located close to the iron ore deposits in the eastern, central and southern regions. *BABA Ispat Pvt. Ltd* in Raniganj (W.B.) smelts iron & steel mainly for local supply from Raniganj to Burdwan (W.B.). *Bhushan Steel Limited* is the largest manufacturer of auto-grade steel in India. At its Sahibabad plant in Ghaziabad, Uttar Pradesh, it has a mill which produces the widest sheets in India for the automotive industry. Among others, the company has in West Bengal a 2-MMT steel plant at Salanpur in Bardhaman district, northwest of Durgapur, and another plant at Bangihatti, near Dankuni.

3.6.1.7 Fertilizer

Until the year 2005, India was almost self-reliant in manufacturing capacity of urea. Since then, the consumption-production gap has widened.

Table 18: Year-wise consumption, production and imports of fertilizers (billion tons)

Year	Consumption	Production	Import
2000-01	1.67	1.47	0.21
2001-02	1.74	1.46	0.24
2002-03	1.61	1.45	0.17
2003-04	1.68	1.43	0.20
2004-05	1.84	1.54	0.28
2005-06	2.03	0.56	0.53
2006-07	2.17	1.61	0.61
2007-08	2.26	0.47	0.76
2008-09	2.49	1.43	1.02
2009-10	2.65	1.62	0.91

Source: Department of Fertilizer, Govt of India

The three states of U.P., W.B. and Bihar contribute almost one fifth to the national production. In U.P., the hinterland districts contribute less than that proportion to the state production, whereas in Bihar and in W.B. the hinterland contribution amounts to almost 100%. TATA Chemicals Ltd is located in Haldia in about 6 km distance from the future Haldia MMT. The company constitutes the largest producer of urea fertilizer in Eastern India which it distributes mainly by railways into all of W.B., Bihar, Jharkhand, Orissa and Assam / Tripura.

Plants are located in U.P. near Allahabad (IFFCO at Phulpur and Indo Gulf at Jagdishpur), in Bihar at Barauni, and in W.B. at Durgapur and Haldia (Tata Chemicals). Overleaf *Figure 24* depicts the location of fertilizer plants:

Figure 23: Location of fertilizer companies

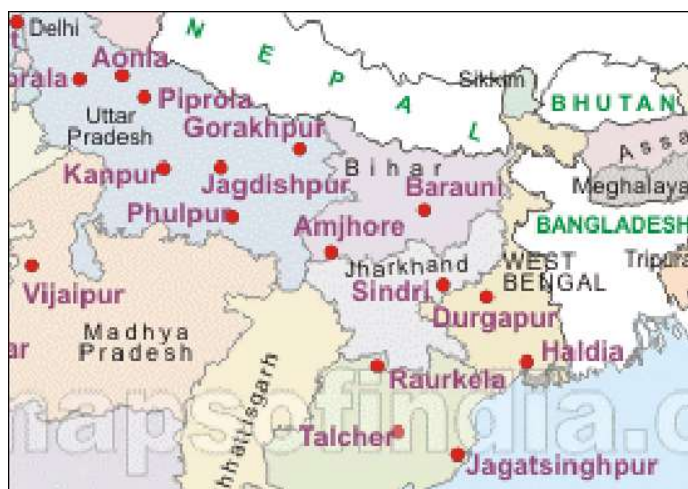

Source: www.mapsofindia.com

The total consumption of fertilizer in India is estimated to be around 25 MMT per annum, of which around 10 MMT per annum are consumed in U.P., Bihar and W.B. There is substantial potential to transport fertilizers from plants to various locations in these three states. A part of this could be moved by inland waterways. Hubs on the NW-1 are required for distribution purposes, ideal locations would be the IWAI facilities at Allahabad, Simariya (Bihar), and Kolkata and/or Haldia.

3.6.1.8 Agro-equipment

Agro Suppliers Syndicate and Debson Pumps Pvt Ltd are both located in Kolkata and deal with agro-equipment and spares. Other suppliers in Kolkata are Rescon (India) Pvt Ltd, Saimaa

Agrotech, and *Durga Bhawani Enterprises* in Howrah. In states other than W.B., prominent examples are *MS Shahdeo Agro Equipment Plant* in Ranchi (Jharkhand) and *Kapila Krishi Udyog Ltd* in Kanpur (U.P.).

3.6.1.9 Food grains and flour

India's north is producing wheat which is needed in the south; the food-grain surplus is mainly confined to the northern states; transportation involves long distances. U.P. and Bihar are the largest agricultural regions where large volumes are generated for transportation to the south. There is a huge requirement of food grains in W.B. and the North Eastern states, which are transported by road/rail as of now. Wheat yields in irrigated areas of northern India (Punjab, Haryana, and Western U.P.) are above 4.5 tons per hectare, while yields in central and western states (Gujarat, Madhya Pradesh, Rajasthan, rest U.P., and Bihar) are relatively lower (2.4-2.8 tons per hectare). India's 2015/16 wheat exports are forecast to decline to 2.0 MMT, with exports restricted to neighboring countries like Bangladesh and Nepal. Despite a zero import duty policy, imported wheat is relatively more expensive than local wheat due to shipping, clearance, and inland transport costs. *Shri Shyam Agro Bloatach Pvt Ltd* in Raniganj (W.B.) produces wheat flour ('atta'), flour ('maida') and cattle feed mainly for local supply at Durgapur, Asansol and Kolkata. In reverse, rice is available in India's south which is needed in the north; the Kolkata region is well known for rice farming. Surplus rice growing states like Punjab, Haryana, U.P., Andhra Pradesh and W.B., Orissa and other eastern states follow intensive rice-wheat or rice-rice cropping systems. Most of the hybrid rice is cultivated in eastern India (e.g., eastern U.P., Bihar, Jharkhand, and Chhattisgarh).

3.6.1.10 Crude vegetable oil

There exist three plants of *JVL*, of which one each is located in Haldia, Bihar and Varanasi. Minor producers are *Adani*, *Rivert Oil* and *Reliable*.

3.6.1.11 Other raw materials

United Phosphorus Ltd is located in Durgachawk Town near Haldia. This company produces raw materials for insecticides.

3.6.1.12 Consumer goods

Motor bikes, cars, container loads with various contents are classified as consumer goods. *JMB Group* is one of India's largest groups with about 3,000 employees at all major and several non-major ports - apart from inland locations - and handles over 6,000 vessels annually. The group is focused on international, coastal and inland transport.

3.6.1.13 Over-dimensional cargo (ODC)

With 11 more power plants scheduled to be commissioned within the next five to eight years, the requirement for ODC is expected to be around 2 MMT. At present, *ABC India Ltd* in Kolkata for instance owns 162 hydraulic axles plus 12 prime movers and a coastal deck loader barge of 1,948 dead-weight tons (dwt) for carriage of heavy cargoes.

3.6.2 Farakka-Munger sector

3.6.2.1 Around Sahibganj

Stone chips and aggregates are the only commodity that is mined at Sahibganj and surrounding regions and transported to several regions mainly on the north of Bihar. Sahibganj, Sakrigali, Mirzachowk, Bakudi, Barharwa and Pakur are the regions where stone chips are mined and loaded for further shipping across regions on the north of Bihar. Stone chips crushers are located at an average distance of 3-4 km from the loading point at Sahibganj railway station.

3.6.2.2 Sakrigali

Sakrigali is a small hamlet which is located 10 km away from Sahibganj and is located on the banks of the Ganges River. The proposed MMT at Sahibganj is located at Sakrigali. There are numerous stone chips crushers located in Sakrigali and generate huge amount of stone chips which are transported to regions on the north of Bihar by road, rail and water.

3.6.2.3 Mirzachowk

Mirzachowk is a town with similar demographic characteristics as Sahibganj and is located about 15 km west of Sahibganj. Stone chips and aggregates are the only commodity that is loaded onto rakes at Mirzachowk railway station. Stone crushers and mines are located within a radius of 5 km from the railway station.

Stone crushers and mines located in Sahibganj, Sakrigali and Mirzachowk also serve the demand in northern Bihar by road transportation.

3.6.2.4 Rajmahal

Rajmahal is a city and a notified area in Sahibganj district in the Indian state of Jharkhand. Rajmahal is the only sub-divisional town in Sahibganj district, located along the banks of the Ganges River. As of 2001 India census, Rajmahal had a population of 17,974. Males constitute 52% of the population and females 48%, giving an indication of the hard physical work in the region. Silica sand mining is carried out along the banks of the Ganges River in areas surrounding Rajmahal. Mangalhat is the area which is home to silica sand mining industries located at a distance of 7-8 km from Rajmahal railway station.

3.6.2.5 Pirpainti

Pirpainti is a sub township located in Bhagalpur district of the Indian state of Bihar. It is the biggest panchayat in Bhagalpur, Pirpainti population counts 9,020 people. Average sex ratio of Pirpainti village is 885, which is lower than Bihar state average of 918.

The Cabinet Committee on Economic Affairs has approved the elaboration of a study on three new rail lines: A new broad gauge line between Ajmer and Sawai Madhopur via Tonk in Rajasthan, construction of a new rail line between Gadag and Wadi in Karnataka and a new broad gauge line between Pirpainti-Jasidih (Mohanpur) in Jharkhand.

3.6.2.6 Bakudi

Bakudi is a small town in Jharkhand where in significant amount of stone crushers are located. There is a continuous activity of loading stone chips onto rakes at Bakudi railway station.

3.6.2.7 Barharwa

Barharwa is a small town in Sahibganj district in the Indian state of Jharkhand. Barharwa is surrounded by the Rajmahal hills all around except towards east. As of 2011 India census, Barharwa had a population of 12,617. The population growth rate of Barharwa is 1.14%.

3.6.2.8 Pakur

Pakur is a district of Jharkhand and is famous for its stone and bead industries. At Pakur, the Ganges River, flowing south-southeast, begins its attrition with the branching away of its first distributary, the Bhāgirathi-Hooghly, which later joins with other tributaries to become the Hooghly River. Pakur district has an area of about 696 km² and a population of 899,200 (2011 Census). Males constitute 53% of the population and females 47%. Pakur has an average literacy rate of 50.2%, lower than the national average of 74.4. The economy of the district is predominantly agricultural; still, the district is also endowed with mineral wealth like black stone, fire clay and coal. However, infrastructural constraints have inhibited the growth of mining and allied industries. One of the main businesses of the city is mining and crushing. It is also known for the manufacturing of crushing and screening equipment. Pakur is also the place where the first indigenous jaw crusher was manufactured by *Bhagwati Prasad Agarwalla*. Since last decade there has been an enormous activity of coal excavation in the area as well. It has one of the biggest reserves of coal in the world. Currently only one block of coal is active in the region. It has been allotted to the Punjab State Government for their captive thermal power plants. The excavation work on behalf of the Punjab State Government is being done by *PANAM*. It is a private - public joint venture between Punjab Government and *AMTA*. Approximately, 500 mines and 800 crushers are in operation with the support of huge labor force. Black stones of Pakur are of superior quality. Pakur railway station is one of the busiest railway stations in terms of loading of stone chips and coal from the nearby mines. Stone chip mines are located within a radius of about 5 km from the railway station and the coal mines are located at Amrapara village. Amrapara is located at a distance of 50-60 km from Pakur railway station.

3.6.2.9 Baghalpur

Baghalpur is a town situated on the southern bank of the Ganges River in the state of Bihar. As of the 2011 India census, Baghalpur town has a population of 410,210 with a metro population of around 0.41 million, while the district as a whole has a population of 3 million. Baghalpur registered average annual population growth of 3.72%, between 2006 and 2010. It is the second largest town in Bihar in terms of urban population next only to Patna. Males constitute 54% of the population and females 46%. Baghalpur has a high average literacy rate of 81.16.

Figure 24: Transport and NW-1 loading stations at Bhagalpur



Source: Consultants from Google Maps

The thermal power plant at NTPC Kahalgaon (see next section) falls under Bhagalpur district. The largest industrial belt of the district is Barari industrial Area, with Kahalgaon industrial area being equally important. The Government of India has established a hand-loom park, while a food park has been established by private entrepreneurs.

Roads: NH80 and NH31 pass through Bhagalpur district. The Vikramshila Setu connects NH80 to NH31. The city has a good road network. Bhagalpur city has approximately 200 km road length. The transport system is good, with cars, taxis and cycle rickshaws easily available. In the city area around 10,000 autos, 500 private taxis and 200 buses are on the road. Bhagalpur is well connected to the major cities of Patna, Kolkata, Ranchi, Jamshedpur, Munger, Gaya, etc. by various national and state highways.

Railways: Bhagalpur Junction railway station is situated on the Khana- Quil loop line which serves Bhagalpur with numerous trains. It is the 3rd busiest railway line in Bihar. About 40 pairs of express trains and 10 pairs of passenger trains operate on this line. Bhagalpur Junction is an A1 grade railway station. It constitutes the highest revenue earner in the Malda Rail Division and third major railway station of Eastern Railway after Howrah and Sealdah. Bhagalpur is well connected with Delhi, Mumbai, Kolkata, Bangalore, Ajmer, Kanpur, Patna, Guwahati, Surat, Munger and other cities. In the 2008 Rail Budget, Bhagalpur was upgraded to a Railway Division. The new rail lines which are under construction are Sultanganj to Deoghar, Bhagalpur to Dumka, Bhagalpur- Godda via Hansdiya, and Banka to Deoghar. It is also the originating station for many superfast and express trains.

3.6.2.10 Kahalgaon

Kahalgaon is a town in Bhagalpur district in the State of Bihar. Kahalgaon Super Thermal Power Station (KhSTPP) is located in Kahalgaon (see overleaf Figure 26). The power plant is one of the coal-based power plants of NTPC. The coal for the power plant is sourced from Rajmahal Coal Fields of *Eastern Coalfields Ltd (ECL)*. Source of water for the power plant is the Ganges River. The total installed capacity of the plant is 2,340 MW. The NTPC thermal power plant at Kahalgaon needs 45,000 metric tons of coal every day for optimal generation

of power at 2,340 MW; but, due to non-supply of coal by ECL, in the past the generation had steadily decreased to make the power situation grim in Bihar.

Figure25: Transport and NW-1 loading stations at Kahalgaon



Source: Consultants from Google Maps

Coal supply problems: Two projects that were perennially short on coal through the whole of last year were NTPC's 2,340 MW Kahalgaon station in Bihar and the 2,100 MW Farakka station in W.B. The irony is that while Kahalgaon is located right on the pithead (at the coal mine itself, so that there is no need to transfer the coal to the plant), Farakka is not too far. And both are among stations that form the backbone of the eastern region's generation sector. While the Farakka station has infrastructure in place to operate at over 90% plant load factor, the utility in 2014 was mostly operating at only 70% because of the short supply of coal. The shortfall in domestic supplies is being made up by imports, which, in turn, jacks up tariffs. The problem here is that most coal reserves in the east are located in restive areas.

NTPC's power plants at Farakka and Kahalgaon require imported coal amounting to more than 5 MMT per annum which is brought through Paradip and Haldia ports. But due to capacity constraints of railways, these power plants regularly face shortage of coal. Further, due to low depth available at Haldia port, bigger ocean-going vessels cannot come there, due to which 70% of imported coal is received at Paradip port and from there transported by railways. Both these power plants are located along the Ganges River (NW-1) quite close to the river bank. IWAI had been working with NTPC on the project of transportation of imported coal by IWT mode from Haldia to Farakka and Kahalgaon. In July 2010, NTPC gave written commitment of transportation of 3 MMT of imported coal from Haldia to Farakka by IWT mode for a period of seven years. Thereafter IWAI and NTPC developed a project envisaging total investment from the private sector. After open competitive bidding M/s *Jindal ITF Ltd* were selected as operator, and the project has been commissioned recently. NTPC has a dedicated railway line between Farakka and Kahalgaon power plants. Hence it is likely that they may transport further 3 MMT of imported coal for Kahalgaon power plant to Farakka by IWT mode. Since there are several existing thermal power plants along the NW-1 and many more are going to come up, success of this pioneering project may pave way for many more projects for transportation of coal on the NW-1.

3.6.3 Munger-Ballia sector

The state of Bihar constitutes an important center of agricultural production:

- Maize accounts for 1.5 MMT (or 10% of country production);
- Sugar cane produces 13.00 MMT;
- Litchi production is 0.28 MMT (Bihar contributes 71% of national production);
- Makhana levels are 0.003 MMT (Bihar contributes 85% of national production);
- Mango is 1.4 MMT (13% of national production);
- Vegetable production is 8.6 MMT (9% of national production);
- Honey Production is 1300 tons (13% of national production);
- Aromatic Rice 0.015 MMT;
- Milk Production: 4.1 MMT;
- Fishery production levels are 0.03 MMT.

Of these volumes, *Annex 4* lists the larger quantities of major commodities per district which had been identified through the market survey.

Figure 26: Munger-Ballia sector with major industrial centers



Source: Google maps; Consultants' information

3.6.3.1 Patna

Bihar's capital Patna has long been a major agricultural hub and center of trade. Its most active exports are grain, sugarcane, sesame, and medium-grained Patna rice. There are twelve sugar mills in and around Patna. *Bihar State Sugar Development Corporation* (BSSDC) sold nine of these mills on lease basis to different parties through tenders issued by SBI Caps earlier. Lauria and Sugauli sugar mills have been taken over by oil major Hindustan Petroleum's subsidiary, *HPCL Biofuels Ltd*, which has invested in generating power and manufacturing ethanol too. Raiyam and Sakari sugar mills are being revived by new investors and are likely to become operational in a year. The remaining two sugar mills at Motipur and Bihta have been sold on lease to *Indian Potash Corporation* and *Pristine Logistic and Infra Project Private Ltd* respectively.

3.6.3.2 Gaya

Gaya is the second biggest economy contributor after Patna for Bihar. It has a large number of household industries like production of agarbattis, production of tilkut and lai, stone crafting, power looms, small scale manufacturing industries, packing industries, plastic products industries, scrap industries and hand looms. Gaya functions as a service center for the surrounding towns and villages. There are no large scale industries / public sector undertakings in the city.

3.6.3.3 Munger

Munger city has many industries in and around the city. Indian Railway has one of Asia's largest and oldest railway workshops at Jamalpur. Munger has India's oldest tobacco manufacturing unit, started in 1905. In mid-2014, ITC Limited set up its first dairy plant in India in Munger city. Finally, Munger city has many small scale industries in and around the city.

3.6.3.4 Barauni

Barauni in Begusarai district is another important industrial town in Bihar. The town is connected with North Bihar via a railway-cum-road bridge across the Ganges River. The major industries here were/ are:

- Indian Oil refinery,
- Barauni Thermal Power Station BSEB,
- Hindustan Fertilizers Corporation (*page is in Hindi*),
- Barauni Dairy,
- Bihar carbon Pvt.Ltd,
- Neo Carbon Pvt.Ltd,
- Premier Industries,
- Graphite India,
- Sortedbyte Business Solutions.

3.6.3.5 Barh

Barh Super Thermal Power Station or NTPC Barh is located in Barh in the Indian state of Bihar. NTPC Barh is located barely 4 km east of the Barh sub-division on NH31 in Patna district. The project has been named a mega power project, and is owned by Indian energy company National Thermal Power Corporation (NTPC). This TPP has a 1,980MW (3x660 MW) block (Stage-1) and a 1,320MW (2x660 MW) extension (Stage-2).

3.6.3.6 Ballia

Ballia City is district headquarters and commercial Market of this district. Ballia holds one government sugar mill and one cotton weaving industry. Although Ballia's core occupation is agriculture, there exist some small industries.

3.6.4 Ballia-Allahabad sector

3.6.4.1 Coal

Imported high-calorie coal: There are several industries around Allahabad, of which two are power plants (NTPC): *IFFCO* and the *Jaypee Group*.

Domestic low-calorie coal: There is a coal mandi in Varanasi (Chandasi Coal Mandi) where coal is purchased mainly for brick burning.

3.6.4.2 Building materials

Two cement plants are located in the Varanasi region: one of the Jaypee Group, the other one of ECO Cements Limited:

1. *Jaypee Plant* produces 2.5 MMT cement per year with destination U.P. and Bihar. The plant is in 9 km distance from the Ganges River, 30 km downstream of Varanasi.
2. *ECO Plant* produces 0.9 MMT cement per year for Bihar (70%), W.B. (15%) and U.P. (15%).

3.6.4.3 Agricultural inputs

Fertilizer: Client for urea fertilizer is the *IFFCO*. *IFFCO* has a plant project at Paradip, but the project (including a 120m jetty) has stopped due to legal issues. The Paradip factory is the largest of five more plants in Gujarat, U.P. and Orissa. *IFFCO* also owns five plants in the Allahabad area. *IFFCO* is planning on using RSVs between Paradip and Haldia sea ports, from thereon using the NW-1 to Bihar and U.P.

3.6.4.4 Food grains and flour

Wheat: India's north is producing wheat which is needed in the south; U.P. and Bihar are the largest agricultural regions; there large cargo volumes are generated to be transported south.

Rice: In reverse, rice is available in India's south which is needed in the north; Kolkata region is well known for rice farming.

Flour: There are many flour mills around Varanasi, most of which are in the Ramnagar industrial area.

3.6.4.5 Edible oil

Crude vegetable oil: There exists a plant of *JVL* in Varanasi.

4 Freight Costs and Tariffs

4.1 Capital-cost recovery mechanism of railway system

Finding resources to finance rail infrastructure is one of the key challenges faced by *Indian Railways (IR)*. Even the core rail network has to be upgraded steadily to keep pace with technological development in order to ensure performance improvement and to adjust the infrastructure to provide sufficient capacity. Thus, covering the operational expenses is not the only aim IR has to reach but also generating adequate resources for replacement and planned investments.

The main clusters of rail investments could be defined as follows:

- Infrastructure (capacity augmentation by new lines),
- Rolling stock (additional or replaced ones),
- Stations and terminals (as the major traffic knots) and
- Technological upgrade and modernization of existing assets.

The expenditure on railway rolling stock and infrastructure as a percentage of total transport expenditure has declined considerably. Measured as a percentage of total transport sector expenditures the rail-related expenditures used to be about 56% in the 7th Plan (1985-90) and have been reduced to 30% in the 11th Plan (2007-12). In the same period the road sector has experienced an increase in investments. The share of rail expenditures in overall GDP has been static at 1% over the years and has gone down to 0.9% in the year 2012/13.

Capital cost in general can be recovered by the implementation of user charge. By this for example the investment for provision of electricity, water and handling facilities could be recovered by the calculation of appropriate fees. The same is valid for wagons and other rolling stock as their utilization has to be "labeled with a price tag". A system should be developed that enables IR to consider for example depreciation and internalized costs by structuring and establishing a pricing system through user charges. An actually on international level common measure for infrastructure cost recovery is the publishing and invoicing of infrastructure usage fees. Their definition could be influenced by the type of traffic (e.g. passenger or cargo traffic), by the gross weight of the train (mainly heavy cargo or light cargo) and length of train, chosen track route (e.g. busy route, special equipped route, fast track route). In Europe for example the establishment of noise-dependent usage-fees is on its way. The trains operating rails cars with special noise-reduced wheels sets and/or with special noise-reduced breaks get a lower fee per route-km than those not providing noise reduction measures. During the elaboration of this report no kind of established infrastructure usage fees have been identified.

In 2007 a report about the difficulties of capital recovery due to missing agreements and/or contracts with users of rail sidings has been published. This report recommended among others:

- Indian Railways draws up an action plan for execution of agreements where they are wanting, and carry it out in a time bound manner.
- The dues to be recovered from the siding owners should be assessed on priority and action taken for recovery thereon.

- All disputes regarding payments between siding owners and railway problems should be resolved on priority, within a specific time period.

Besides over-proportional direct and cross-subsidies, external financing of projects has to be considered. Examples are the Eastern DFC Project which mainly financed through multilateral/bilateral debt covered by the World Bank and Japan International Cooperation Agency (JICA). The Dankuni–Sonnagar section of the Eastern DFC is to be implemented through public private partnerships (PPP), and the balance requirement would need to be met through budgetary support. *IR* has set an ambitious target for PPP that the share of internal resource generation is expected to fall from 35% in 2016 to 20% in 2017 – the last two years of the in the 12th Five-Year Plan. Investments in Railways can also be supported by setting up PPP-structure (public-private-partnership). A procedure globally as well as in India proved in sectors like ports, telecommunications, energy generation and supply, constructing and operating airports and of course during road (mainly highways) construction and operations. PPP projects related for example to rolling stock manufacturing, modernization of railway stations, multimodal terminals and logistics parks and probably even freight train operations, offer suitable opportunities for private participation.

Capital cost recovery could also be achieved by enhancing the existing service portfolio and establishing new source of income. An important aspect of *JR East* (one of the largest rail companies in Japan) business is for example that it earns almost 30% of its revenues from non-transportation business. Non-transportation business at *JR East* includes station space utilization (e.g. shops, restaurants, advertising), shopping centers and office buildings. Like *JR East*, *DB Deutsche Bahn AG* (German State-owned Rail Company) generates revenues by nonrail business. At *DB* these are almost 50% annually. It runs almost 25,000 passenger trains per day and produces 1 billion train-km only for freight operations annually. Total revenue of *DB* was 39.7 billion Euros in 2014. *DB* is increasingly becoming active in markets outside Germany with 41% of the revenues coming from international operations. It is one of the leading logistics providers globally and handles more than 1 MMT of air freight as well as almost 2 million over sea standard containers TEU. The generation of additional revenues in order to strength the core business could also be of strategic importance for *IR*.

4.2 Current freight costs and rates

This section deals with the current freight transport costs and rates (prices) of the three different transport modes that are rail, road and IWT.

4.2.1 Railway

IR is the dominating rail agency in India. Its freight portfolio mainly consists out of nine major commodity groups, namely coal, raw materials, iron and steel, iron ore (export as well as domestic), cement, food grain, fertilizer, mineral oil and container services (ex-/import as well as domestic).

Apart from the existing segments where railway already has a dominant presence, several other opportunities are expected to become more and more suitable. These are in respect

of commodities for example fast moving consumer goods, fly-ash and automobiles. This development would be supported and triggered by establishing partnerships with logistics providers and investing in special-purpose rolling stock and transportation services.

In this particular case, costs are the amount of money a railway company has to spend in order to provide a suitable service. These are expenditures for staff (administrative and operational), rolling stock (rail cars and locomotives), infrastructure (utilization fee or even construction and maintenance), energy (diesel or electricity) and further services (e.g. insurance and financing). There are fixed costs for e.g. staff and rolling stock which occur independently from transported cargo volumes. On the other side there are variable costs that occur if transport services are executed. The variable costs include among other energy/fuel and infrastructure abrasion or fees as they in general only occur during operations.

Looking on rail as an integrated system covering transport services and infrastructure provision, the shares of the relevant categories are as shown in the following table. Shares are listed in descending order.

Table 19: Variable costs of rail services

Cost Items	Share of total costs	
	Share	Cumulative
Fuel / Traction	27.5%	27.5%
Station Staff	16.3%	43.8%
Repair & Maint. Waggon	11.2%	55.0%
Repair & Maint. Infrastructure	9.5%	64.5%
Operating Expenses	7.9%	72.4%
Repair & Maint. Others	5.6%	78.0%
General Superintendence	5.4%	83.4%
Repair & Maint. Locomotives	5.2%	88.6%
Staff Welfare	4.4%	93.0%
Retirements Benefits	3.8%	96.8%
Misc. Working Expenses	3.3%	100%
Total Costs	100%	

Source: Based on Planning Commission "Total Transport System Study"

The freight rate is the price charged by a railway company for moving a commodity from origin to destination (for freight details see Table 20 "Choice of Freight Rates (valid since April 2015) in Rs per km"). The actual amount charged varies based on the commodity, the weight to be handled and the distance to be travelled. A rate lower than offered by the competitors or competing transport modes respectively is a competitive rate. If the absolute freight is equal or even higher in comparison to the competing transport modes and companies, the service has to be made more attractive by added incentives or added supplementary services like handling of cargo documents, coordination of pre- and on-carriage or longer payment terms.

In general the freight rate is determined by what a client is willing to pay, the railway company is willing to accept, and the competition with other transport modes is allowing to be charged. The freight rate is together with the product itself, the extent of promotion for the product, and placement of product one of the business variables over which the rail companies can exercise some degree of control.

The purchase of rail transport should be fixed by a contract, left to be determined by an agreed-upon formula at a future date, or discovered or negotiated during the course of dealings between railway company and client (forwarder, manufacturer etc.). The manipulation of prices is not allowed as well as a misleading indication of price such as charging for items that are reasonably expected to be included in the offered freight rate.

IR owns the infrastructure, most of the handling facilities and provides transport services at the market. At the end of the fiscal year 2012/13 the company provided a rail network of about 65,436 route-km. The network consists out of three different track gauges. The main share is broad gauge infrastructure covering 57,140 route-km. The remainder route-km are 5,999 km of metric gauge and 2,297 km of narrow gauge infrastructure. Out of the total route-km 20,884 km are electrified which equals almost 32%. A route-km measures the length of a rail route while the fact if it is a single- or double-track route stays unconsidered. If all tracks and sidings are measured separately it totaled up to a track-km length in 115,833 km in 2013.

On 31st March 2013 IR operated 5,345 diesel-powered, 4,568 electric-powered and 43 steam-powered locomotives (total of all gauges). Concerning the rail cars or wagons the Indian Railways operated at the end of the fiscal year 2012/13 around 48,037 passenger carriages, 9,841 electric-multiple units (also for passenger transportation), 39 rail cars and 6,614 “other coaching vehicles” (total of all gauges). At the same date 244,731 wagons have been operated for cargo transport.

Figure 27: Development of total traffic earnings and cargo traffic earnings (in Rs million)

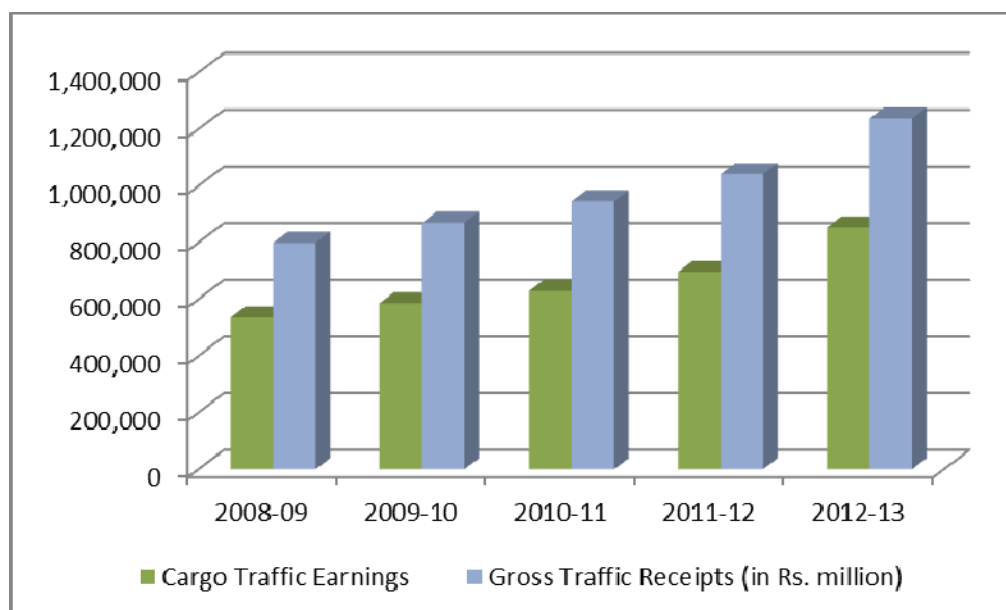

Source: Indian Railways Key Statistics 1970/71 to 20 12/13; Consultant’s illustration

The figure above shows the development of earnings generated by transport services (traffic) provided by IR from the fiscal year of 2008/09 to 2012/13. Over this period the share of

earnings generated by cargo traffic is 67.3% in average (within a range of 66.5% to 68.9%). The gross traffic receipts increased by 11.6% annually in average during the illustrated period while the growth in 2012/13 have been 18.8% which is distinctly above the previous years and totals Rs 1,237.3 billion. Earnings generated by cargo traffic increased by 12.5% in average with again stronger growth in 2012/13 by 22.6% which totals Rs 852.6 billion. Based on the available statistic a distribution of earnings to the NW-1 hinterland is not possible sofar. But the prior considered earnings show the importance of cargo rail traffic for the whole rail industry.

Construction costs of a single lane route are about Rs 60 million per km and of a double track route about Rs 100 million per km. Construction costs of tracks (steel tracks, wooden sleepers, and ballast bed) cover about 40% of the total cost and have to be replaced in general every 40 years. Construction costs of bridges are about 20% of the total cost and they have a life of 100 years. Costs for necessary buildings (e.g. stations, signal tower, basic handling facilities) are about 5% of the total cost and have a life of 80 years. The remainder share is used for further construction works like embankment. Maintenance costs have been reported as Rs 1.0 million per track-route km per month.

Figure 28: Distribution of construction costs

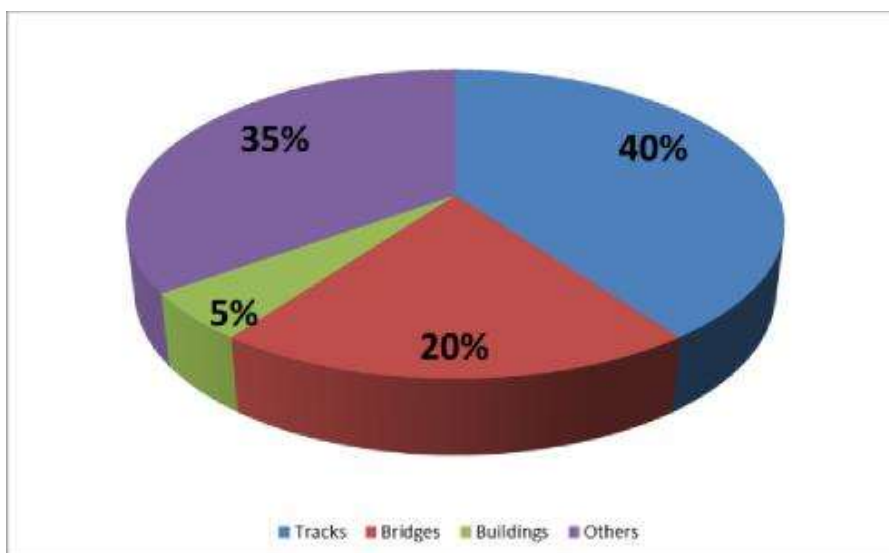

Source: Market surveyor / stakeholder interview with Indian Railways

The consideration of expenses for infrastructure and rolling stock for repair and maintenance as well as for operations could not be distributed separately for passenger and cargo traffic. The following figure shows the development of the ordinary working expenses (without appropriation to rail funds). The average development of the ordinary working expenses is about 14.7% annually - coming from Rs 547.32 billion in 2008/09 ending up in 2012/13 by Rs 841.84 billion. The average share of maintenance and repair (M&R) expenses over the shown period are about 38.9%. The average share of operating expenses is a little bit higher lying by slightly more than half of the costs reaching 50.9%. The remainder %-share to 100% is expressed as "other expenses" which have not been identified more detailed.

Figure 29: Development of ordinary working expenses (in Rs million)

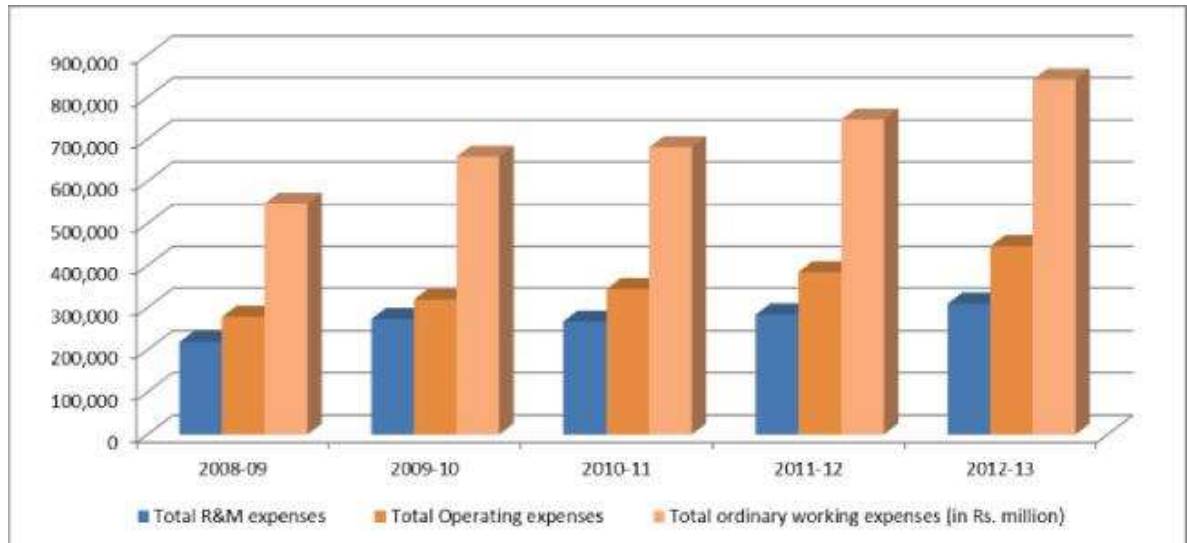

Source: Indian Railways Key Statistics 1970/71 to 20 12/13; Consultant's illustration

The total M&R expenses in 2012/13 have been by Rs 309.72 billion while the total operating expenses reached Rs 446.13 billion.

The overall development of these two types of expenses is that the share of M&R expenses is slightly decreasing over the years while the share of operating expenses is slightly

The following figure shows the development of net ton-kilometers (ton-km). These express how many kilometers the complete cargo volume measured in tons has been transported. Weights of rolling stocks are not included. Again the nine major commodities are shown. Over the complete period coal has been the dominant commodity. It reaches more than 303,000 million ton-km in 2012/13. Second largest commodity group has changed during the years. It has been iron ore in 2008/09 and 2009/10 with 50,798 and 53,947 million ton-km, to be superseded by cement for the next two years with 56,952 million ton-km in 2010/11 and 63,036 million ton-km in 2011/12. In 2012/13 food grains have been ranked second with 71,335 million ton-km. Except for iron ore all commodities show an increase in ton-km. Iron ore is declining to 38,091 million (coming from 50,798 million on 2008/09).

Figure 30: Development of ton-km by commodities (in million ton-km)

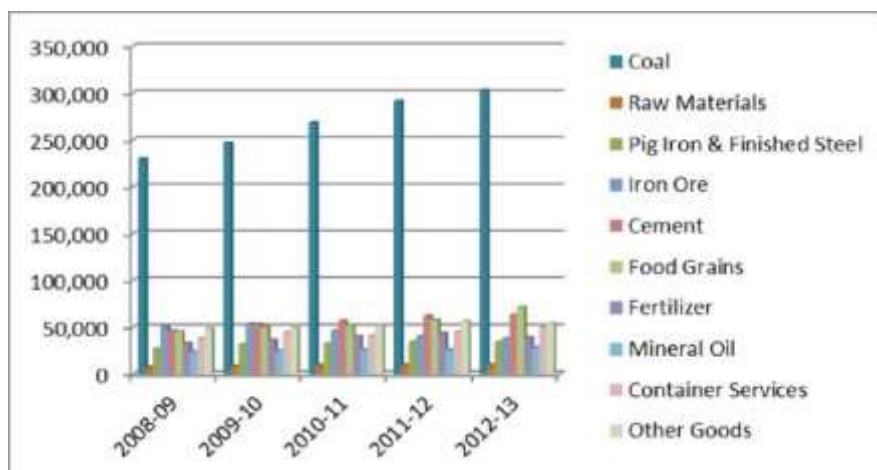

Source: Indian Railways Key Statistics 1970/71 to 20 12/13; Consultant's illustration

The figure below shows the distribution of commodities with the individual percentage share in regards of total ton-km of the nine dominant commodities groups in the year 2012/13.

Figure 31: Distribution of %-share of ton-km by commodities in 2012/13

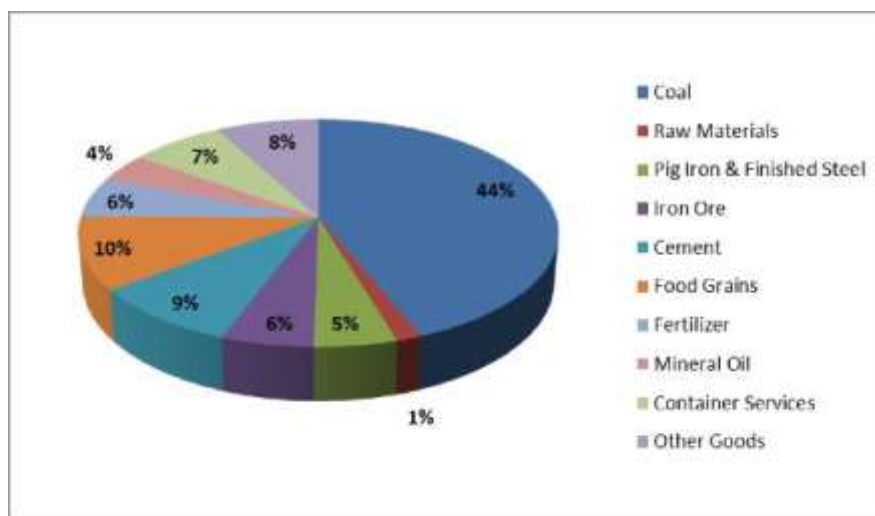

Source: Indian Railways Key Statistics 1970/71 to 20 12/13; Consultant's illustration

The statistics do also mention the earnings per ton-km in average. The average covers all commodities and is only valid for cargo traffic. The trend of the development is consequently positive. There is a slight annual increase from 2008/09 until 2010/11. In detail the average earnings have been 93.84 Paise in 2008/09 increasing by 0.99% until 2009/10 reaching 94.77 Paise. Until 2010/11 the average rose with 2.34% up to 96.99 Paise per ton-km. The increase for the following year became a bit more dynamic reaching 4.62% or 101.47 Paise per ton-km to make a comparatively huge step in 2012/13 with 18.94% or 120.69 Paise per ton-km.

Figure 32: Development of annual earnings per ton-km

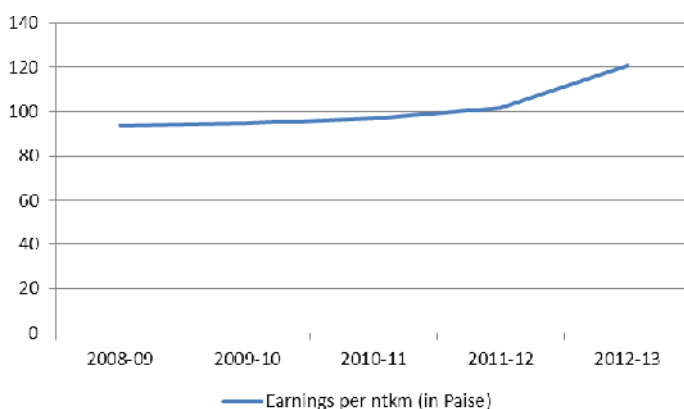

Source: Indian Railways Key Statistics 1970/71 to 20 12/13; Consultant's illustration

The IR published in April 2015 at the beginning of the fiscal year 2015/16 updated freight rates for rail transport. Already in February 2015 India's Railway Minister Suresh Prabhu proposed a hike in freight rates that could directly impact consumers of essential commodities as well as the steel industries. The Minister of Railways has then proposed a freight hike of 0.8% on iron ore and steel, a 6.3% increase on coal transport and an increase in freight rates for grains and pulses by 10% during the fiscal year 2015/16. The base rates are depending on the commodity which has to be transported as well as on the distances that has to be travelled. In total there

are 16 categories or better commodity groups defined. The IR calls them tariff lines. Three of the 16 tariff lines are defined as “Low Rate Tariff Line” (LR 1 – LR3) and the remainder 13 rates as “General Tariff Lines” (Tariff 100 – 200). Besides the definition of Tariff Lines the IR has also defined distance categories. First distance category is “1-125” (km). For a good that has to be transported up to 125 km a certain freight rate has been defined. The regulations of IR states that each transport volume has been invoiced by a transport distance of 125 km minimum even it has been transported less. The following distance categories are covering additional 25 km until the category “476 -500”. Up to the category “951-1000” there are 50-km-steps. The distances covered by the following categories are getting longer stepwise. The final category is “3251-3375”. In total there are 46 distance categories. Per combination of commodity group and distance category a rate has been defined. This leads to 736 different rates in total. The range of rates starts with Rs 99.2 per ton of cotton, fruits, groceries or motor vehicles (LR 3) over a distance up to 125 km and ends with Rs 4,701.6 per ton of acids, alcohols and industrial gases (*General Tariff 200*) to be transported up 3,375 km. A choice of tariff lines is displayed in the following table.

Table 20: Choice of freight rates (valid since April 2015) in Rs per km

Distance in km	Low Rated Tariff	General Tariff Lines					
	LR 1	130	140	145	150	160	180
	(Organic) Fertilizer	Food Grains / (Chem.) Fertilizer	Cement	Coal	Pig Iron	Steel / Iron Ore	Mineral Oil
1 - 125	134.7	184.3	198.5	205.6	212.7	226.9	255.2
126 - 150	164.3	224.8	242.1	250.7	259.4	276.6	311.2
151 - 175	184.1	251.9	271.3	281.0	290.7	310.1	348.8
176 - 200	205.9	281.7	303.4	314.2	325.1	346.7	390.1
201 - 225	226.0	309.3	333.1	345.0	356.9	380.6	428.2
226 - 250	247.7	338.9	365.0	378.0	391.1	417.1	469.3
251 - 275	269.3	368.6	396.9	411.1	425.3	453.6	510.3
276 - 300	290.7	397.8	428.4	443.7	459.0	489.6	550.8
301 - 325	310.9	425.5	458.2	474.6	491.0	523.7	589.1
326 - 350	331.9	454.2	489.2	506.6	524.1	559.0	628.9
351 - 375	352.9	483.0	520.1	538.7	557.3	594.4	668.7
376 - 400	374.3	512.2	551.6	571.3	591.0	630.4	709.2
401 - 425	395.9	541.7	583.4	604.2	625.1	666.7	750.1
426 - 450	417.2	571.0	614.9	636.8	658.8	702.7	790.6
451 - 475	438.2	599.7	645.8	668.9	692.0	738.1	830.3
476 - 500	460.2	629.7	678.2	702.4	726.6	775.0	871.9
501 - 550	503.6	689.1	742.1	768.6	795.2	848.2	954.2
551 - 600	546.6	748.0	805.6	834.3	863.1	920.6	1,035.7
601 - 650	589.3	806.4	868.4	899.4	930.5	992.5	1,116.5
651 - 700	631.8	864.5	931.0	964.3	997.5	1,064.0	1,197.0
701 - 750	674.6	923.1	994.1	1,029.6	1,065.2	1,136.2	1,278.2
751 - 800	716.6	980.6	1,056.0	1,093.7	1,131.5	1,206.9	1,357.7
801 - 850	758.7	1,038.2	1,118.0	1,158.0	1,197.9	1,277.8	1,437.5
851 - 900	800.6	1,095.5	1,179.8	1,221.9	1,264.1	1,348.3	1,516.9
901 - 950	842.4	1,152.7	1,241.4	1,285.7	1,330.1	1,418.7	1,596.1
951 - 1000	884.2	1,209.9	1,303.0	1,349.5	1,396.1	1,489.1	1,675.3
1001 - 1100	968.6	1,325.5	1,427.4	1,478.4	1,529.4	1,631.4	1,835.3
1101 - 1200	1,053.3	1,441.3	1,552.2	1,607.6	1,663.1	1,773.9	1,995.7
1201 - 1300	1,137.5	1,556.6	1,676.4	1,736.2	1,796.1	1,915.8	2,155.3
1301 - 1400	1,221.3	1,671.3	1,799.8	1,864.1	1,928.4	2,057.0	2,314.1
1401 - 1500	1,305.1	1,785.9	1,923.3	1,992.0	2,060.7	2,198.1	2,472.8
1501 - 1625	1,386.4	1,897.2	2,043.2	2,116.1	2,189.1	2,335.0	2,626.9
1626 - 1750	1,493.1	2,043.2	2,200.4	2,279.0	2,357.6	2,514.7	2,829.1
1751 - 1875	1,535.4	2,101.1	2,262.7	2,343.5	2,424.3	2,585.9	2,909.2
1876 - 2000	1,637.7	2,241.1	2,413.5	2,499.7	2,585.9	2,758.2	3,103.0
2001 - 2125	1,654.2	2,263.7	2,437.8	2,524.9	2,612.0	2,786.1	3,134.3
2126 - 2250	1,751.5	2,396.8	2,581.2	2,673.4	2,765.6	2,949.9	3,318.7
2251 - 2375	1,767.4	2,418.5	2,604.6	2,697.6	2,790.6	2,976.6	3,348.7
2376 - 2500	1,860.4	2,545.8	2,741.6	2,839.5	2,937.5	3,133.3	3,524.9
2501 - 2625	1,889.6	2,585.8	2,784.7	2,884.2	2,983.7	3,182.6	3,580.4
2626 - 2750	1,979.6	2,708.9	2,917.3	3,021.5	3,125.7	3,334.1	3,750.8
2751 - 2875	2,007.6	2,747.3	2,958.6	3,064.3	3,170.0	3,381.3	3,803.9
2876 - 3000	2,094.9	2,866.8	3,087.3	3,197.5	3,307.8	3,528.3	3,969.4
3001 - 3125	2,121.9	2,903.7	3,127.0	3,238.7	3,350.4	3,573.8	4,020.5
3126 - 3250	2,206.9	3,019.9	3,252.2	3,368.4	3,484.5	3,716.8	4,181.4
3251 - 3375	2,233.3	3,056.0	3,291.1	3,408.7	3,526.2	3,761.3	4,231.4

Source: www.indianrailways.gov.in/railwayboard/uploads/directorate/traffic_comm/Freight_Rate_2k15/RC_08_15.pdf;
Consultant's illustration; excerpt of complete rates list

The costs of rail cargo traffic have been derived by figures mentioned in the *Total Transport System Study* elaborated on behalf of the Planning Commission in 2008. The figures have been adjusted to reach current level by including an inflation factor. The mentioned costs are financial costs which represent the expected costs for an operator. The following table shows the ton-km costs for IR movement of cargo distinguished

- by location between plain (incline < 1 in 100) and ghat (incline > 1 in 100; hilly) sections,
- by traffic infrastructure between single and double lines, and
- between diesel and electric powered trains.

Total fully-distributed costs vary between Rs 0.72 ton-km on a plain electric double-line section and Rs 1.29 per ton-km on a ghat diesel single-line section.

Table 21: Railway costs for movement of cargo by cost elements (in Rs per ton-km)

ELEMENTS OF COSTS (Rs. per ntkm)	PLAIN SECTION (incline < 1 in 100)				GHAT SECTION (incline > 1 in 100)			
	DIESEL		ELECTRIC.		DIESEL		ELECTRIC	
	SL	DL	SL	DL	SL	DL	SL	DL
Operational	0.45	0.40	0.31	0.28	0.82	0.72	0.49	0.43
Terminal	0.04	0.04	0.04	0.04	0.04	0.04	0.04	0.04
Overheads	0.06	0.06	0.06	0.06	0.05	0.05	0.05	0.05
Capital	0.35	0.36	0.37	0.39	0.39	0.40	0.41	0.43
User Charge	-	-	-	-	-	-	-	-
Total Financial Costs	0.88	0.84	0.76	0.72	1.29	1.21	1.00	0.94

Source: Based on Planning Commission "Total Transport System Study"; Consultant's calculation and depiction

The operational costs do include energy costs for fuel or electricity, staff as well as maintenance and repair. Fuel costs are responsible for 25-30% of total costs. The terminal costs cover the occurring costs by handling or storing cargo at rail terminals. The train has to be unloaded and/or loaded and the cargo is mainly stored before loaded to or discharged from a train. The overheads do cover the administration cost and other mainly staff costs that are necessary for rail traffic but cannot be distributed to a certain route of transport. Capital costs do include among others expenditures for pension funds as well as depreciation costs. In comparison to other transport modes no infrastructure charges could be identified.

Table 22: Railway costs in average per commodity for movement of cargo (in Rs Per ton-km)

Commodities	PLAIN SECTION (incline < 1 in 100)				GHAT SECTION (incline > 1 in 100)			
	Diesel		Electric		Diesel		Electric	
	SL	DL	SL	DL	SL	DL	SL	DL
Wheat	1.02	0.97	0.86	0.84	1.56	1.44	1.18	1.09
Fruits & vegetables	1.05	1.00	0.89	0.86	1.60	1.48	1.21	1.13
Coal	1.09	1.02	0.92	0.89	1.65	1.52	1.25	1.14
Fertilizer	1.05	1.00	0.89	0.88	1.58	1.46	1.21	1.12
Sugar	1.01	0.96	0.85	0.84	1.56	1.44	1.17	1.08
POL	1.20	1.13	1.00	0.97	1.84	1.69	1.37	1.26
Cement	1.08	1.02	0.92	0.90	1.61	1.49	1.24	1.14
Livestock	2.55	2.40	2.14	2.08	3.91	3.61	2.94	2.71
Iron & Steel Products	1.12	1.05	0.93	0.90	1.73	1.58	1.29	1.18
Container heavy wt.	1.30	1.22	1.10	1.06	1.97	1.82	1.49	1.38

Source: Based on Planning Commission "Total Transport System Study"; Consultant's calculation and depiction

The definition of costs in Rs per ton-km in relation to certain commodities has been executed within the "Total Transport System Study" published in 2008. The figures mentioned in the table above have been adjusted to current cost level based on the figures published in 2008.

This is possible as the meaning of the basic assumptions has not changed during the years. Commodity wise costs are mainly influenced by three major cost drivers. These are the

- share of the distance a train has to travel empty after unloading or before loading (empty return ratio),
- average cargo volume/quantity to be loaded per wagon (train utilization), and
- average lead of cargo (the distance the cargo has to be transported).

The empty return ratio expresses if the commodity is available for both directions making it a paired or matched transport or not. If coal for example is transported to a power plant it is very unlikely that the same rail set is transporting coal from the power plant on its way back. In order to keep the idle time of wagons as low as possible and the overall utilization of rail cars as high as possible, cargo has to be found to be transported by the train on its way back (to the coal terminal). To achieve this aim it has to be checked in this example, if waste material like fly ash (generated during power generating process at the power plant) could be transported on the way back or if there is a origin of suitable cargo within an appropriate distance to travel to, pick up the cargo and return to the coal terminal to pick the next load of coal to be brought to the power plant.

The utilization per train is also important as the costs per ton increase the less nominal tons the train can load. Especially cargo that needs comparatively much space while being quite light and by this not generating high wagon loads leads to a reduced train utilization as this is measured in tons per train and or tons per wagon. Thus, the costs per ton for lighter, voluminous cargo are higher than for cargo with a higher density.

The third criterion is the average distance a commodity has to be transported as the costs per ton-km decrease the longer the distance to be travelled becomes. Thus, actually the earnings per ton and/or ton-km do increase in general if the distance gets longer. This is mainly influenced by the fact that the preparation of a train transport needs every time the same effort despite the duration or distance of the transport. If for example these "set-up costs" could be distributed over more travel-km the costs per km decrease.

4.2.2 Road

The following table overleaf shows the elaborated freight rates of road transport within the hinterland of NW-1 mainly focused on the transport from/to Haldia, Kolkata and Sahibganj. The cargo has been clustered by groups. Besides existing studies on this issue the Consultant executed comprehensive market surveys which included numerous interviews with truck drivers in the specific regions. For general cargo as well as for Ro-Ro cargo no current freight rates could be identified. The rates for dry bulk vary between Rs 1.95 per ton-km to Rs 2.41 per ton-km considering a truck with a work load of 16 tons completely utilized. Also bagged goods have been identified at all three locations providing a rate range about Rs 162 per ton-km to Rs 2.39 per ton-km. Liquid bulk for road transport has only been reported for Kolkata GRT with a rate of Rs 4.0 per ton-km. The highest freight rate has been elaborated for road transport of containers. The rates differ from Rs 6.33 per ton-km in the Kolkata region to Rs 7.95 per ton-km from/to Haldia.

Table 23: Road freight rates per region and cargo group (in Rs per ton-km)

Rs. per ntkm	Road (16 t cargo per truck)			
	Tariffs			Average
	Haldia MMT	Kolkata GRT	Sahibganj MMT	
Dry bulk	1.95	2.00	2.41	2.12
Liquid bulk	n/a	4.00	n/a	4.00
Bagged	2.39	2.28	1.62	2.10
General	n/a	n/a	n/a	n/a
Neo-bulk	n/a	3.11	n/a	3.11
Ro-ro	n/a	n/a	n/a	n/a
Container	7.95	6.33	n/a	7.14

4

Note: Rates were also quoted to market surveyors during interviews

Source: Planning Commission; Manual on Economic Evaluation of Highway Projects in India, Indian Road Congress, Consultant's calculation

Freight tariff-rate levels for cargo trucking are totally adverse to any experience in, for instance, Germany (as described in the previous section) and indicate that road transport in India is performed with depreciated trucks under heavy overweighed cargo loads without taking responsibility (and cost coverage) for destroyed roads and other external disadvantages.

Table 24: Road costs for movement of cargo (Rs per ton-km)

Rs. per ntkm	16 tonnes loaded truck	
	Rs per ton-km	Share
Fuel & oil	1.87	56.1%
Labor	0.15	4.4%
Repair & maintenance	0.09	2.7%
Tolls	0.34	10.3%
Depreciation	0.06	1.8%
Capital	0.21	6.2%
Overhead	0.32	9.5%
Congestion cost (15% of VOC)	0.30	9.1%
Total	3.33	

Note: For estimating VOC, MAV with average speed of 45 km/h on a 4-lane (2 lanes in each direction) road configuration; Overhead costs at 15% of VOC (source: World Bank: Measuring Road Transport Performance, 2005)

Source: Manual on Economic Evaluation of Highway Projects in India, Indian Road Congress, IRC:SP:30-2009

4.2.3 Inland-waterway transport

Similar to road and railway transport, in inland shipping the costs per ton-km also decrease with increasing vessel size. The costs of inland shipping also depend on the direction of steaming: As diesel constitutes the highest proportion of operating costs, the difference between upstream and downstream steaming is most significant. The following table indicates the total cost for inland-waterway shipping as between Rs 0.74 per ton-km for a 3,000-ton vessel downstream and Rs 2.00 per ton-km for a 1,000-ton vessel upstream. Due to the quite intense current of the river, the upstream direction requests much more performance by the vessel's engine than downstream.

Table 25: IWT costs for movement of cargo (Rs per net ton-km)

Upstream	Capacity (tons)			Downstream	Capacity (tons)		
	1000	2000	3000		1000	2000	3000
Cost Component				Cost Component			
Operational (variable)	1.29	1.05	0.93	Operational (variable)	0.62	0.48	0.42
Operational (fixed)	0.23	0.12	0.09	Operational (fixed)	0.23	0.12	0.09
Capital	0.48	0.29	0.23	Capital	0.48	0.29	0.23
Total	2.00	1.47	1.25	Total	1.33	0.90	0.74

Source: Spring Costing IWT, New Delhi, 02 March 2016

The Consultants verified the above costs through costing information from two other sources⁴⁶. Below *Table 26* depicts the costs as stated by Eastern Navigation Pvt Ltd. As this line operates its own ship yard, these verification figures in the below table are based on true costs arising on the Indian market.

Table 26: IWT costs for movement of cargo – cost verification (Rs per net ton-km)

Upstream	Capacity (tons)			Downstream	Capacity (tons)		
	1000	2000	3000		1000	2000	3000
Cost Component				Cost Component			
Operational	0.77	0.48	0.36	Operational	0.32	0.19	0.13
Total R&M	0.03	0.02	0.01	Total R&M	0.03	0.02	0.01
Overhead	0.08	0.05	0.04	Overhead	0.03	0.02	0.01
Capital	0.32	0.20	0.16	Capital	0.32	0.20	0.16
User Charge (to IWAI)	0.02	0.02	0.02	User Charge (to IWAI)	0.02	0.02	0.02
Total	1.20	0.75	0.58	Total	0.72	0.44	0.35

Source: Eastern Navigation Pvt Ltd, Kolkata, January 2016

The verification provided cost figures below the figures provided by *Spring Costing*. However, the cost differentials are very similar with both sources in that the difference in operational costs between a 1,000-ton and a 2,000-ton barge is double that of the difference between a 2,000-ton and a 3,000-ton barge.

From the above cost figures, the Consultants calculated future freight prices on the NW-1 as basis for their transport forecasting model. They first added a 10% profit margin on the total freight costs. Secondly, they compared the future cargo volumes downstream of Barh (where 2,000-ton barges can ply) with the future cargo traffic upstream of Barh (which will be carried by 1,000-ton barges). Finally, the Consultants applied individual stowage factors in their model

⁴⁶ Azzura Marine Liners Pvt Ltd, Kolkata, October 2015; Eastern Navigation Pvt Ltd, Kolkata, January 2016

to come to specific future freight prices on the NW-1 for each cargo type. They had to consider that a vessel operator needs to calculate his costs for the entire round trip in order to come to the specific freight price of a voyage, as he will usually return with an empty vessel hold from his voyage. These freight prices are elaborated further in *Chapter 10.1*.

5 Regional Traffic Flows

5.1 Freight transport patterns

5.1.1 Haldia – Farakka sector

5.1.1.1 Commodity movements and freight tariff rates

The market survey identified a total of more than 16.2 MMT in the Haldia area, out of which about 15.0 MMT move between origins and destinations through the survey area. About 1.2 MMT arrive from other states (mainly Orissa, Maharashtra, Karnataka) outside the survey area to Haldia Dock Complex, thus without any opportunity to transfer any of this cargo onto the NW-1. Following figure depicts the volumes moved in the Haldia area by commodity groups which had been identified during the Consultants’ market survey (for the individual cargo movements by origin-destination legs see Annex 3).

Figure 33: Commodities moved through Haldia and Sagar Island

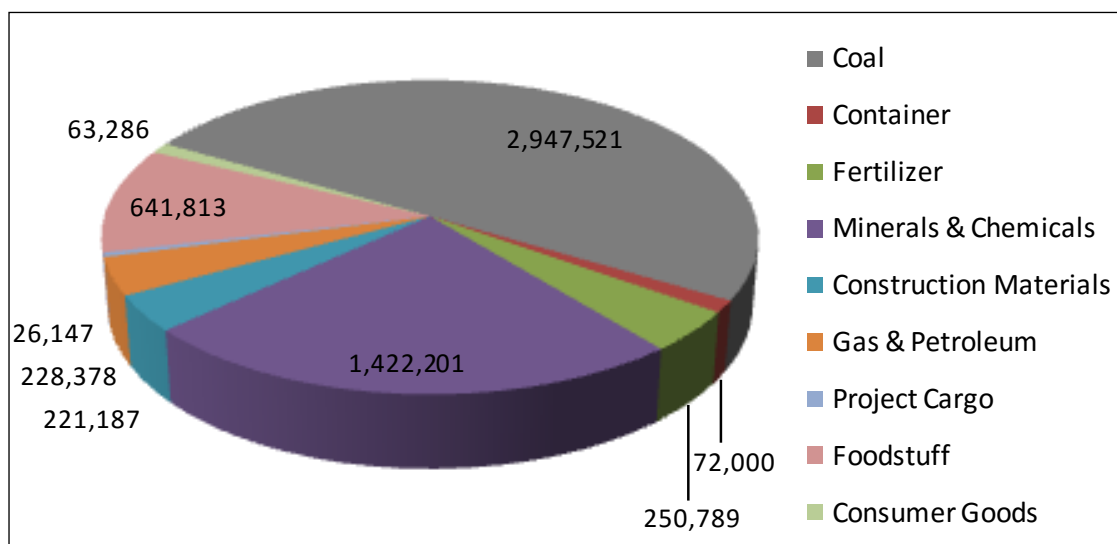

Source: Consultants’ Market Survey, August-October 2015

It becomes obvious that Haldia Dock Complex is a bulk port. More than 95% of the surveyed commodities within the port are moved in and out by Indian Railways. It is mainly containers which are transported on the road.

The overleaf table depicts commodities identified by the Consultants’ market survey.

Table 27: Commodities by origin and destination in Haldia and Sagar Island (tons)

Commodity	Cargo Type	Origin Cargo	Destination Cargo
Coal	Dry bulk	354,892	2,592,629
Fly Ash		7,300	1,333,461
Natural Aggregates			97,500
Iron Ore		0	76,840
Limestone		4,600	
Fertilizer	Bagged	163,918	86,871
Food Grains			65,813
Logs & Wood	Neo-bulk	60,000	
Steel		50,000	13,687
		2,335	23,812
Project Cargo	Liquid bulk	11,352	217,026
Petroleum			
Textiles	General Cargo	41,000	
Food			576,000
Other Cargo		22,286	
Containerized Cargo	Container	72,000	
Total		789,683	5,083,639

Source: Consultants' Market Survey, August-October 2015

The overleaf figure gives an impression of the distribution of cargo origin-destination traffic through Haldia.

A comparison of the average freight tariffs presently applied by the land transporters with the freight tariffs applied by the Consultants (based on the very few IWT-tariffs offered on the NW-1) implies a theoretical price advantage of NW-1 shipments. This advantage is, however, leveled out by additional costs, as IWT cannot offer door-to-door services where producers and/or users are not located directly on the waterway. Instead, pre- and onward carriage is usually required to cover for the 'last mile' with cost implications arising from additional cargo handling (see *Chapter 4* for a detailed discussion).

Figure 34: Commodities moved through Haldia and Sagar

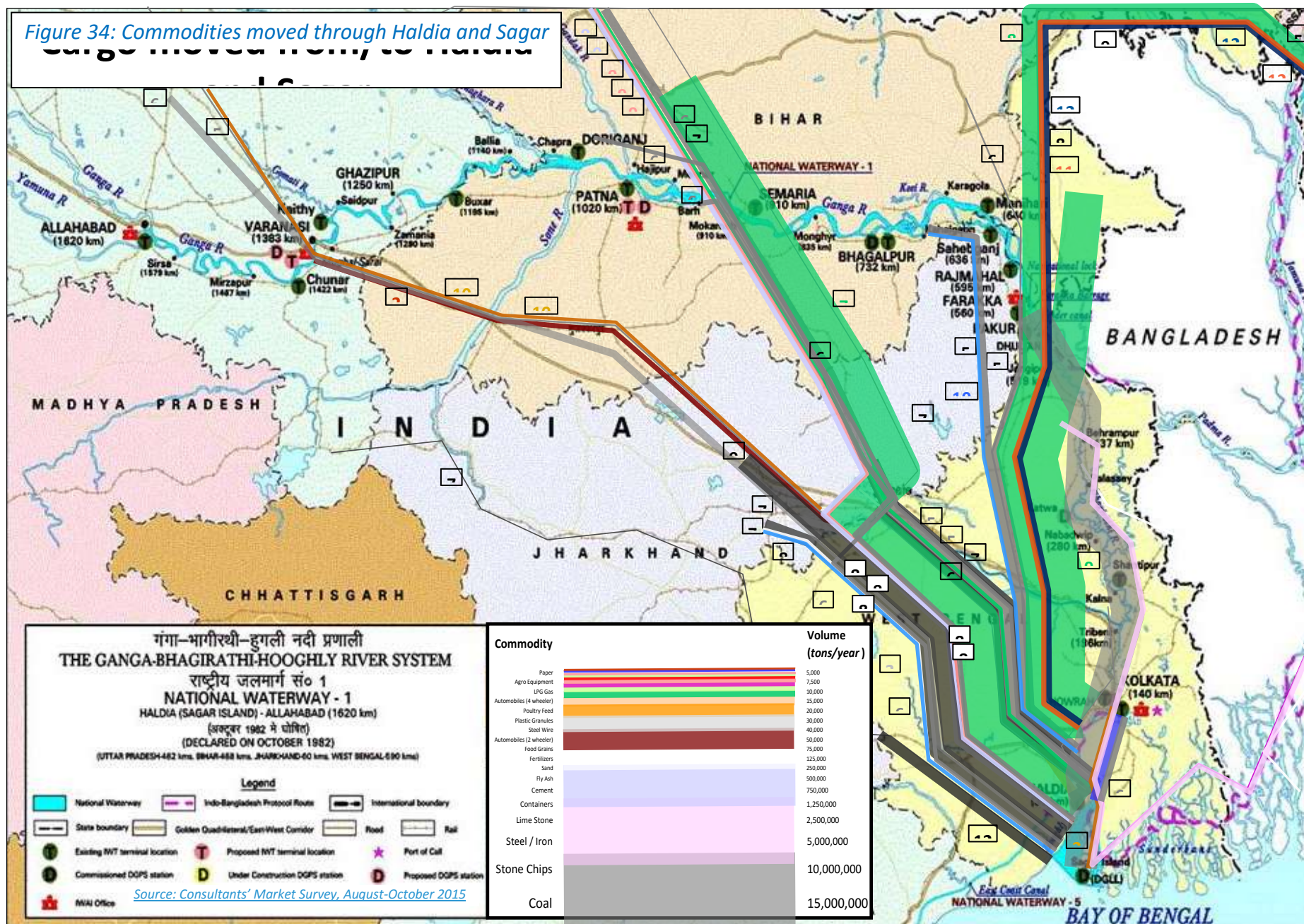

The market survey in the Kolkata area (Zone 1) was much more extensive, as most producers and consumers are located in this area (see *Annex 1* for their exact location). Following figure depicts the volumes moved in the Kolkata area by commodity groups which had been identified during the Consultants' market survey (for the individual cargo movements by origin-destination legs see *Annex 3*).

Figure 35: Commodities moved through Kolkata-Farakka region

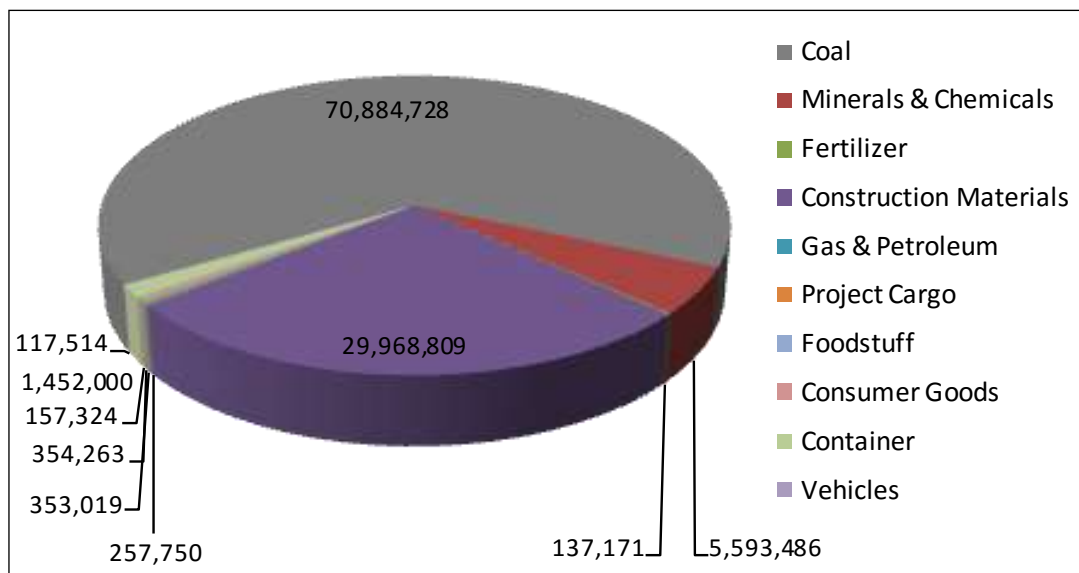

Source: Consultants' Market Survey, August-October 2015

The following table depicts commodities identified by the Consultants' market survey:

Table 28: Commodities by origin and destination in the Kolkata-Farakka region (tons)

Commodity	Cargo Type	Origin Cargo	Destination Cargo
Coal	Dry bulk	13,091,961	57,792,767
Fly Ash		454,914	1,067,000
Sand		94,300	3,429
Natural Aggregates		14,066,676	7,274,516
Iron Ore		44,001	26,656
Limestone		3,998,344	2,571
Fertilizer	Bagged	137,000	171
Cement		568,500	21,723
Food Grains		177,540	10,085
Logs & Wood	Neo-bulk	63,120	-
Steel		275,586	7,600,959
Project Cargo		130,500	222,519
Gas & Petroleum	Liquid bulk	250,550	7,200
Textiles	General cargo	4,500	52,050
Food		148,238	18,400
Other Cargo		77,074	23,700
Containerized	Container	-	1,452,000
Vehicles	Ro-ro	117,514	-
Total		33,700,318	75,575,746

Source: Consultants' Market Survey, August-October 2015

Costs to the potential users of the NW-1 constitute the most important, but by no means exclusive, criteria for their eventual decision to switch traffic from land onto water. The following section discusses these pros and cons as formulated by the interviewees of the market survey.

5.1.1.2 Thermal coal

Everett India Pvt Ltd in Kolkata is a big shipping agent distributing iron & steel, general cargo, limestone and coal on the international market. India's coal mines are located mainly in seven states: India's railways are a federal government-run monopoly, in the fiscal year 2014/15 they transported 508 MMT of domestically-produced and imported coal, according to coal ministry data. Road transport is more expensive and many of the country's roads are unsuitable for heavy bulk transport. About 25% of domestically-produced coal was moved by road in the fiscal year 2014/15, with a further 16% transported via 'merry-go-round' systems serving power plants located close to mines.

Coal freight accounted for nearly half of the total 1.05 billion tons transported by railways in 2014. Railway capacity utilization ranges between 115% and 150% on the two major trunk routes from Delhi-Howrah (Kolkata) on the eastern corridor. The 1,839 km DEFC between Dankuni in W.B. and Ludhiana in Punjab would ease the movement of coal from the eastern region mines to power stations in the north. Some of the coal being imported at Kolkata may also use this track. Coal alone is expected to account for about two-thirds of the estimated 90 MMT per year plus annual freight traffic in this direction by 2022.

IWAI had been working with NTPC on the project of transporting imported coal by IWT mode from Haldia to Farakka and Kahalgaon. In July 2010, NTPC gave written commitment of transportation of 3 MMT per annum of imported coal from Haldia to the Farakka TPP by IWT mode for a period of seven years. Thereafter IWAI and NTPC developed a project envisaging total investment from private sector. After open competitive bidding M/s Jindal ITF Ltd were selected as operator and the project has been commissioned recently. NTPC has a dedicated railway line between Farakka and Kahalgaon power plants. Hence it is likely that a further 3 MMT per annum of imported coal for Kahalgaon power plant may be transported to Farakka by IWT mode under the same project. Since there are several existing thermal power plants along the NW-1 and many more are going to come up, success of this pioneering project may pave way for many more projects for transportation of coal on NW-1. IWAI has also identified a few more cargo specific projects with private sector investment for transportation of 3 MMT per annum coal for NTPC's power plant at Barh in Bihar.

5.1.1.3 Stone chips

Chandak & Associates in Kolkata are order supplier for such aggregates which they distribute domestically and on the international market.

5.1.1.4 Cement

Bagged cement is transported from Allahabad and Varanasi to Kolkata by rail (Shalimar Railway Junction and Howrah Goods Yard) and from Patna by road.

5.1.1.5 Iron & steel

BABA Ispat Pvt Ltd in Raniganj (W.B.) is keen to trade through waterways if service is available.

5.1.1.6 Fertilizer (urea)

Fertilizer can be imported at Kakinada port, then transported to Haldia MMT and finally onward on the NW-1. Trains can carry fertilizer and manually discharge at IWT terminals by means of a conveyor belt to load / discharge. *TATA Chemicals Ltd* in Haldia would be prepared to ship approximately 70,000 tons annually on the NW-1 subject to notification on transit subsidy in comparison to rail freight rates. Client for urea fertilizer is *IFFCO*. *IFFCO* is planning on using river-sea vessels (RSV) between Paradip and Haldia sea ports, from thereon using the NW-1 to Bihar and U.P. Additionally, *Pioneer Agro Industries* and *Bicco Agro Products Pvt Ltd*, both located in Kolkata, cater mainly for the domestic market.

5.1.1.7 Food grains

FCI ships food grains of by IWT mode between Andhra Pradesh, Kolkata and Tripura (through Ashuganj); and within NW-2 on its northern banks.

5.1.1.8 Agro-equipment

Agro Suppliers Syndicate and *Debson Pumps Pvt Ltd* in Kolkata distribute their agroequipment and spares even beyond the region's borders.

Crude vegetable oil: Crude vegetable oil can be bound for Nepal, if containerized and handled either at Baghalpur, Patna or Ghazipur.

5.1.1.9 Limestone

Karnani Minerals Pvt Ltd, located in North Kolkata, trades limestone and sand in the region.

5.1.1.10 Other raw materials

United Phosphorus Ltd near Haldia produces raw materials for insecticides for the regional market.

5.1.1.11 Consumer goods

JM Baxi & Co (JMB) is a shipping agent, forwarder, port & terminal operator specialized in the transport of containers, bulk and project cargo.

5.1.1.12 Over-dimensional cargo (ODC)

In 2014, *Prism Logistics* carried 325 metric tons of heavy equipment on barge from Haldia to Allahabad. This company handles only ODC. *ABC India Ltd* in Kolkata owns 162 hydraulic axles plus 12 prime movers and a coastal deck loader barge of 1,948 dwt for carriage of heavy cargoes. The enterprise is specialized in multi-modal transportation in coastal and inland waterways for heavy ODCs and also heavy project transportation by road in all conditions (especially in the hilly terrain of Northeast India). *Eastern Navigation Pvt Ltd* is a shipping line (river transport only) located in Kolkata. This line is specialized in the transport of heavy lifts and ODCs in the region and in all other inland waters of the country.

The overleaf figure gives an impression of the wide range of commodities being transported through Kolkata, albeit the very largest part of this transport is so far being done by truck or train.

Figure 36: Commodities moved through Kolkata and Pakur

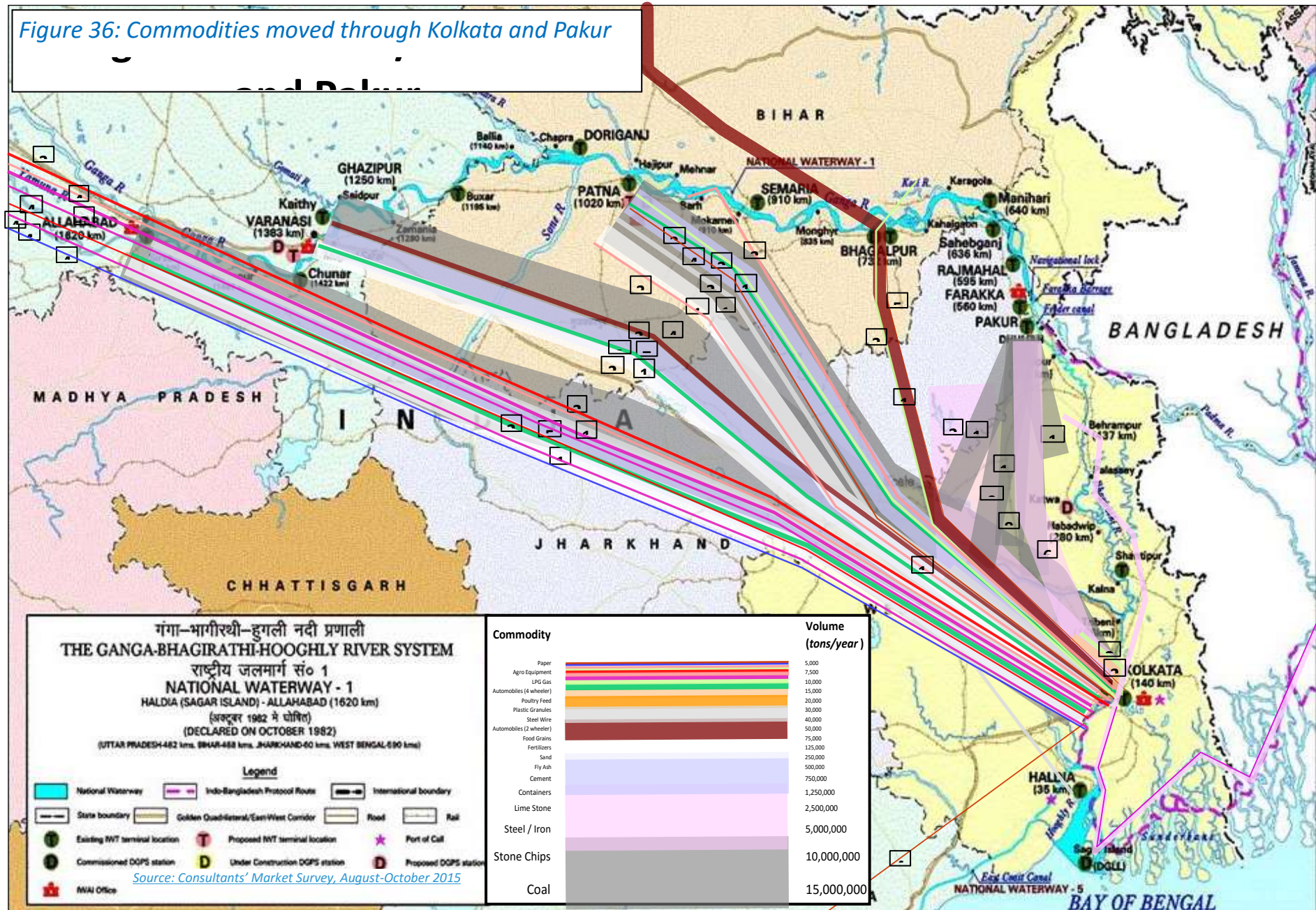

5.1.2 Farakka-Munger sector

In this sector, railway is the preferred mode of transportation with trucks being the next preferred mode. Bad road conditions and ban on movement of heavy truck loads across Kahalgaon and Baghalpur bridges are the prime reasons for the lower amount of road trucking. In the Consultants' market survey, stakeholders were interviewed to arrive at an average amount of stone chips and aggregates transported by road to estimate the potential amount that can be considered for the proposed Sahibganj MMT. The following sections detail the amount of commodities shipped by rail, road and waterways from several regions across the influence area considered for the market survey.

5.1.2.1 Around Sahibganj

Loading of commodities: The volume of stone chips loaded onto rakes at Sahibganj railway station during the year 2014-15 amounted to 0.42 MMT (monthly breakdown see Table 1 of Annex 5). Only stone chips and aggregates are loaded at Sahibganj railway station.

Loading of Stone Chips (2014-15)	Amount
Total (MMT)	0.429
Average per day by Rail (tons)	1,138

It can be seen that, during the year 2014-15, an average of 1138 tons of stone chips were loaded at Sahibganj railway station. The destinations and the distances by rail along with the unit cost are given in Table 29.

Table 29: Destinations served from Sahibganj railway station - Stone chips and aggregate

Sr. No	Destinations	Distance by Rail from Sahibganj	Travel Time (hrs)	Cargo Distribution (%)	Cargo Volume (tons/day)	Rate in ton-km by Rail (Rs)
1	Karpurigram, Bihar	269	10.5	7.6%	87	1.58
2	Darbhanga, Bihar	300	11.8	84.8%	161	1.53
3	Siwan, Bihar	420	16.5		161	1.49
4	Chakia, Bihar	362	14.2		161	1.54
5	Narkatiaganj, Bihar	473	18.6		161	1.46
6	Sitamarhi, Bihar	368	14.4		161	1.52
7	Janakpur road, Bihar	342	13.4		161	1.53
8	Barauni, Bihar	211	8.3	7.6%	87	1.69

Source: Consultants' Market Survey, August-October 2015

Travel time is calculated by taking into account the average speed observed for freight trains across India. Research studies have opined that 25 km/h is the average speed of a goods train and this had been considered in estimating the travel time. However, several times goods trains are stopped for hours at various locations giving priority to passenger trains. Several station managers have expressed the fact that there is no assurance on the travel time of the goods train as they are never run on a scheduled time table.

Stone chips are categorized under Class 150 of freight rates and the corresponding rates prescribed under the observed distance bracket are considered for estimating the fare per ton-km of travel. Trucks are utilized for transporting stone chips from the mines to the loading

point where in manual loading is done onto the rakes at the railway siding. Loading charges per ton vary from Rs 40 to Rs 50.

Unloading of commodities: Along with the loading of stone chips and related materials, cement and rice grains are unloaded at Sahibganj railway siding. The volume of unloaded stone chips observed at Sahibganj railway station during the year 2014-15 amounted to 0.15 MMT (monthly breakdown see Table 1 of Annex 5).

Unloading of Stone Chips (2014-15)	Amount	Rakes (no)
Total (MMT)	0.149	58
Average per day by Rail (tons)	409	

On a monthly average, 3 rakes of food grains and 2 rakes of cement are unloaded at Sahibganj railway station. The origins of cement and food grains along with the distances and cost of transportation are given in Table 30.

Table 30: Origin of commodities unloaded at Sahibganj railway station

Commodity	Origin	Distance by Rail (km)	Distance by Road (km)	Cargo Distribution (%)	Cargo Volume (tons/day)	Rate per ton-km by Rail (Rs)
Cement	AKT, Akaltara	835	786	33.3%	58	1.34
	DGR, Durgapur	251	295	33.3%	58	1.45
	JBCT, Jojobera	430	420	33.3%	58	1.43
Food Grain	Hirakud, Odisha	712	777	33.3%	87	1.20
	Raipur, Chhattisgarh	972	931	33.3%	87	1.15
	BRGA, Bargarh Road	747	787	33.3%	87	1.14

Source: Consultants' Market Survey, August-October 2015

After unloading at Sahibganj railway station, food grains are transported to Food Corporation of India (FCI) warehouses which have a railway siding hence incurring no additional costs of transportation after unloading. However, cement after unloading is disbursed to local use in trucks.

As an example, an OD-pair is presented in the following:

The Consultants have identified almost 180,000 tons of stone chips trucked from Sahibganj to Narayanpur Ananth (Bihar) in 2014 over a distance of more than 300 km. This OD-pair is analyzed further in Chapter 5.3.

Table 31: Feasible cargo OD-pair via Sahibganj - Stone chips and aggregates

Origin	Destination	Transport Mode	Distance [km]	Travel Time Est. [days]	Volume 2014 [tons]
Sahibganj	Narayanpur Ananth (Bihar)	Truck	305	0.6	179,200

Source: Consultants' Market Survey, August-October 2015; calculations by Transport Model

5.1.2.2 Sakrigali

The amount of loading stone chips recorded during the year 2014-15 at Sakrigali railway station is given overleaf (monthly breakdown see Table 1 of Annex 5):

Loading of Stone Chips (2014-15)	Stone Chips	Stone Ballast
Total (MMT)	0.546	0.398
Average per day by Rail (tons)	1,496	1,090

It can be seen that during the year 2014-15, Sakrigali railway station recorded almost 2,600 tons of loaded stone chips plus ballast per day. The destinations served from Sakrigali railway station along with the distances and the cost involved are given in Table 32.

Table 32: Destinations served from Sakrigali railway station - Stone chips and aggregates

Destination	Distance by Rail from Sakrigali (Km)	Rate per Ton	Rate per ton-km by Rail (Rs)	Cargo Distribution (%)	Cargo Volume (tons/day)	Distance by Road (Km)	
Kiul	180.09	325.1	1.81	3.4%	87	196	
Begusarai	232.17	391.1	1.68	13.4%	87	210	
Mokama	214.10	356.9	1.67		87	229	
Durgapur	243.21	391.1	1.61		87	297	
Bakhthiyarpur	257.88	425.3	1.65		87	275	
Darbhanga	307.70	491	1.60		3.4%	87	300
Fatuha	281.43	459	1.63	59.8%	119	299	
Gaya	309.32	491	1.59		119	332	
Danapur	312.99	491	1.57		119	335	
Mansi	281.28	459	1.63		119	162	
Janakpur road	350.28	557.3	1.59		119	353	
Chakia	369.91	557.3	1.51		119	374	
Khajauli	363.24	557.3	1.53		119	377	
Sonpur Junction	312.72	491	1.57		119	324	
Buxar	421.02	625.1	1.48		119	463	
Gauthamsthan	375.22	557.3	1.49		119	389	
Hathua	445.63	658.8	1.48		119	478	
Kanti	334.91	524.1	1.56		119	338	
Chandauli	497.13	726.6	1.46		119	278	
Mughal sarai	512.33	795.2	1.55		13.4%	87	541
Bhabua Road	459.82	692	1.50			87	495
Japla	434.54	658.8	1.52	87		479	
Siwan	427.12	658.8	1.54	87		459	
Mairwa	448.44	658.8	1.47	6.7%	87	481	
Sitamarhi	375.54	557.3	1.48		87	377	

Source: Consultants' Market Survey, August-October 2015

Freight charges given in Table 32 are taken into account while calculating the tariff per ton-km of travel by railways. Furthermore, several transport agencies operating in the region were consulted for ascertaining the cost of travel by truck. It has been found that trucking agencies charge an amount ranging at Rs 3.01-3.89 per ton-km of travel by road in the Sahibganj region. The cost charged in the Pakur region is in between Rs 3.00-3.50 per ton-km of travel. It can be seen that the trucking cost is about 2 to 2.2 times higher than that incurred by rail.

Apart from transporting stone chips by rail and truck, this commodity is also transported in small dinghies to the other side of the Ganges River where it is picked up again and transported further by trucks to places on the north of the NW-1 and to Bihar. Stone chips mined at Sakrigali are transported to the other side particularly at Manihari by small boats ('naukas'). The distance from Sakrigali to Manihari on the NW-1 is about 15 Km. Route course and the location on the map is shown in Figure 38. Along with these naukas, there is a barge service provided by local authorities to ferry people which also offers roll on roll off (ro-ro) service to trucks carrying stone chips from Sahibganj. It is observed that this service makes 4 trips in a day ferrying 7 trucks (loaded with 9 tons of stone chips) on each trip. Hence, this local service ferries about 28 trucks of 9 tons each from Sahibganj to Manihari during one day. Fare collected at Sahibganj for ro-ro services amounts to Rs 1,300 for a loaded truck (9 tons) and Rs 750 for an empty truck. Additionally to the local authorities, the GoI runs a ship named 'Rajagopalachari' which offers ro-ro services for trucks from Sakrigali to Manihari. On an average, about 40 tons of stone chips are loaded onto a truck and about 16 trucks are shipped in one go from Sahibganj to Manihari. This ferry service offers only two trips per day. The fare collected is a lump sum amount which comes down to about Rs 6,000 for 40 tons per truck load.

Figure 37: Route map-Sakrigali to Manihari by naukas

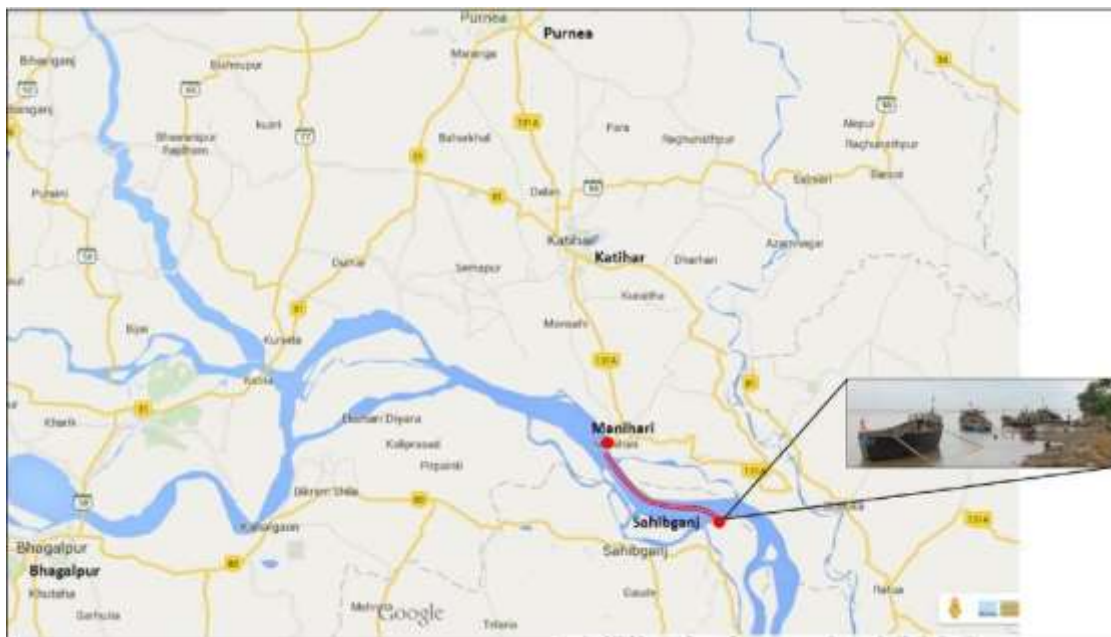

Source: Consultants' Market Survey, August-October 2015

Naukas crossing the NW-1 from Sahibganj to Manihari are unauthorized services run by local groups. The quantity of material ferried is not recorded and is regarded as unofficial mining and transportation. Discussion with local people revealed that about 200-250 naukas are used per day to ferry stone chips from the Sahibganj side of the Ganges River to Manihari. Each nauka has a holding capacity of 50-60 tons. They charge about Rs 200 per ton for one crossing. This fee also includes the loading and unloading charges at Sahibganj and Manihari respectively. Loading of stone chips observed at railway stations and onto naukas is shown in Figure 39 overleaf.

Figure 38: Means of commodity transport



Source: Consultants' Market Survey,

Stone chips dumped at Manihari from naukas are further loaded onto trucks for transport to regions in the north, namely Katihar, Purnea, Janakpur, Chakia, Saharsa, Dharbanga, etc. The waterway from Sakrigali to Manihari forms a very vital transportation link, as a bridge to cross the river is located only near Baghalpur where restrictions on heavy truck loads are in place. This lack of transport infrastructure has given rise to unofficial transportation means like naukas in this region. Hence, there is a huge potential of transporting stone chips across the river at Manihari because of the reduction in trucking costs and travel time. The distance from Sakrigali to Manihari by road is about 197 km, whereas on the waterway this distance is shortened to only 15 km. Naukas take about 2-2.5 hours to reach Manihari from Sakrigali.

Furthermore, demand at all the locations along the NW-1 can be met by IWT with lower cost and less time. Movement of heavy truck loads on the roads has inflicted heavy damage to the pavement making it worse for further movement of trucks during the monsoon season. Damages in the form of potholes and rutting for several kilometers are noticed on the main road network connecting regions to the east and west of Sahibganj. Worse road conditions have further become a deterrent to road trucking. The condition of the roads leading to the loading points is shown in overleaf *Figure 40*.

Figure 39: Severe damage inflicted due to heavy truck loads



Source: Consultants' Market Survey, August-October 2015

5.1.2.3 Mirzachowk

Trucks are used to transport stone chips from the nearby mines to the loading point at the railway station. The amount of stone chips loaded at Mirzachowk railway station (monthly breakdown see Table 1 of Annex 5) during the year 2014-15 is as follows:

Stone Chips Loading (2014-15)	Amount
Total (MMT)	0.437
Average per day by Rail (tons)	1,197

It can be seen that, during the year 2014-15, Mirzachowk railway station recorded about 1,200 tons per day of loading. The destinations served from Mirzachowk railway station along with the distances and the cost involved are given below in Table 33.

Table 33: Destinations served from Mirzachowk railway station - Stone chips and aggregates

Sr. No	Destinations	Distance from Mirzachowk (km)	Cargo Distribution (%)	Cargo Volume (tons/day)	Rate per ton-km by Rail (Rs)
1	Jamalpur Junction	112	7.2%	87	1.90
2	Karpurigram	253	92.8%	185	1.68
3	Narayanpur Ananth	294		185	1.56
4	Janakpur Road	327		185	1.60
5	Khajauli	340		185	1.54
6	Kati	311		185	1.57
7	Tarsarai	297		185	1.54

Source: Consultants' Market Survey, August-October 2015

Stone chips and aggregates moved by rail from Sahibganj, Sakrigali and Mirzachowk to the destinations mentioned above total almost 5,000 tons per day. Also, the amount of stone chips moved by naukas from Sakrigali to Manihari by waterways is about 12,600 (225 naukas of 55 tons each plus 28 trucks of 9 tons each). The cargo volume trucked to northern Bihar is pegged at 25,600 tons per day (1,600 trucks with an average load of 16 tons each).

5.1.2.4 Rajmahal

Silica sand mined at Mangalhat is transported in trucks until Rajmahal railway station for loading onto railway rakes. The amount of silica sand loaded at Rajmahal railway station during the year 2014-15 is given overleaf (monthly breakdown see Table 1 of Annex 5):

Silica Sand Loading (2014-15)	Amount
Total (MMT)	0.62
Average per day by Rail (tons)	171

It can be seen that during the year 2014-15, on an average about 170 tons of silica sand was transported from Rajmahal railway station. Furthermore, about 10-15 truckloads (average weight of 16 tons) of silica sand are trucked to areas in and around Kolkata. Destinations by rail include several processing industries which use silica sand as raw material. Destinations and costs involved by railways and roads are given in Table 34.

Table 34: Destinations served from Rajmahal railway station - Silica sand

Sr. No	Destination	Distance from Rajmahal by Rail (km)	Cargo Distribution (%)	Cargo Volume (tons/day)	Rate per ton-km by Rail (Rs)
1	Bokaro Steel Plant, Jharkhand	390	33.3%	57	1.52
2	Hatia, Ranchi	420	33.3%	57	1.49
3	Kolkata, Sodpur	250	33.3%	57	1.56

Source: Consultants' Market Survey, August-October 2015

5.1.2.5 Pirpainti

Coal from Rajmahal coal mines is loaded at Pirpainti railway station. Rajmahal coal mines are located in Lalmaitya which is 36 km away from Pirpainti railway station. Rajmahal coal mines have a railway siding where coal is loaded and from where it is transported to Kahalgaon Thermal Power Station. The volume of coal loaded at Pirainti railway station during the year 2014-15 amounted to 0.64 MMT (monthly breakdown see Table 3 of Annex 5).

Coal Loading (2014-15)	Amount
Total (MMT)	0.644
Average per day by Rail (tons)	1,764

Coal loadings are closed during the monsoon season because of less production activity. Also, it was learnt that there has been a problem with the loading agencies which often go on strike resulting in zero loadings at Pirpainti railway station. A similar problem was seen also at Rajmahal railway station. Demand from thermal power stations at Varanasi is met by coal mined at Lalmitiya making trucking of coal less reliable. Logistics companies have expressed their willingness to move onto waterways, as delivering coal at Varanasi would be a cheaper option by waterways and would also provide an alternative to the problems created by the loading agencies. The thermal power stations/regions served by the coal mined at Lalmatiya are given in below Table 35.

Table 35: Destinations served from Pirpainti railway station – Coal

Sr. No	Destinations	Distance from Pirpainti by Rail (km)	Cargo Distribution (%)	Cargo Volume (tons/day)	Rate per ton-km by Rail (Rs)
1	Banaras Thermal Power Station, Varanasi	501	24.0%	423	1.53
2	Farakka Thermal Power Station, Murshidabad, West Bengal	96	6.9%	122	2.14
3	Kahalgaon Thermal Power Station (NTPC Kahalgaon), Bhagalpur, Bihar	55	6.9%	122	3.74
4	Titagarh Thermal Power Station, Titagarh, Kolkata	507	6.9%	122	1.52
5	Bakreshwar Thermal Power Station, Chinpai, West Bengal	204	6.9%	122	1.69
6	Mejia Thermal Power Station, Bankura, West Bengal	591	6.9%	122	1.41
7	Sagar Dighi Thermal Power Station, Manigram, West Bengal	153	6.9%	122	1.84
8	Rosa Thermal Power Station, Shahjahanpur, Uttar Pradesh	971	6.9%	122	1.39
9	Hindalco Thermal Power Station, Sonbhadra, Uttar Pradesh	672	6.9%	122	1.43
10	Kolaghat Thermal Power Station, West Bengal	507	6.9%	122	1.52
11	Budge Budge Thermal Power Station, 24 Paraganas, West Bengal	376	6.9%	122	1.52
12	Bandel Thermal Power Station, Bandel,	367	6.9%	122	1.47

Source: Consultants' Market Survey, August-October 2015

5.1.2.6 Bakudi

The volume of stone chips and aggregates loaded during the year 2014-15 at Bakudi railway station amounted to 0.43 MMT (monthly breakdown see Table 1 of Annex 5). The stone crushers are located within a radius of 1-2 km from the loading point at Bakudi railway station.

Stone Chips & Aggregates Loading (2014-15)	Amount
Total (MMT)	0.429
Average per day by Rail (tons)	1,138

It can be seen that more than 1,100 tons of stone chips and aggregates were loaded on a daily average at Bakudi railway station during the year 2014-15. The destinations served from Bakudi railway station and the costs involved are given in Table 36.

Table 36: Destinations served from Bakudi railway station - Stone chips and aggregate

Sr. No	Destinations	Distance from Bakudi by Rail (km)	Cargo Distribution (%)	Cargo Volume (tons/day)	Rate per ton-km by Rail (Rs)
1	Dharbhanga, DBG	346	4.9%	173	1.51
2	Chhalkia, CAA	409	4.9%	173	1.53
3	Siwan, SV	466	90.2%	535	1.49
4	Narayanpur Ananth, NRPA	356		535	1.57
5	Karpurigram, KPGM	315		535	1.56
6	Harinagar, HIR	535		535	1.49
7	Samasthipur, SPJ Hathua,	309		535	1.59
8	HTW	484		535	1.50

Source: Consultants' Market Survey, August-October 2015

5.1.2.7 Barharwa

The railway station at Barharwa is a loading point for stone chips and aggregates. The amount of stone chips and aggregates loaded at Barharwa railway station during the year 2014-15 amounted to about 1.0 MMT (monthly breakdown see Table 1 of Annex 5).

Stone Chips & Aggregates Loading (2014-15)	Amount
Total (MMT)	1.019
Average per day by Rail (tons)	2,912

It can be seen that during the year 2014-15, on an average about 2,900 tons of stone chips and aggregates were loaded in a day at Barharwa railway station. The destinations served from Barharwa railway station and the costs involved are given in Table 37.

Table 37: Destinations served from Barharwa railway station - Stone chips and aggregate

Sr. No	Destination	Distance from Barharwa by Rail (km)	Cargo Distribution (%)	Cargo Volume (tons/day)	Rate per ton-km by Rail (Rs)
1	Dharbhanga	354	87.6%	245	1.57
2	Kapurigram	323		245	1.52
3	Narayanpur Ananth	364		245	1.53
4	Tarsarai	367		245	1.52
5	Khajauli	410		245	1.53
6	Janakpur Road	397		245	1.49
7	Sitamarhi	422		245	1.48
8	Kanti	381		245	1.55
9	Chakia	416		245	1.50
10	Harinagar	543		245	1.47
11	Gautamsthan	422	12.4%	87	1.48
12	Siwan	473		87	1.46
13	Mairwa	495		87	1.47
14	Hathua	492		87	1.48

Source: Consultants' Market Survey, August-October 2015

5.1.2.8 Pakur

Trucks are used to transport coal and stone chips from the mines until the loading points around Pakur railway station. The amount of stone chips and coal loaded at Pakur railway station during 2014-15 (monthly breakdown see Tables 1 and 2 of Annex 5) is as follows:

Stone Chips and Coal Loading (2014-15)	Coal	Stone Chips
Total (MMT)	7.316	5.023
Average per day by Rail (tons)	13,762	20,044

In the above table it can be seen that about 13,800 tons of stone chips more than 20,000 tons of coal are loaded at Pakur railway station, thus making it the busiest loading station in the influence area of Sahibganj MMT. The destinations served from Pakur railway station and the costs involved are given in overleaf Table 38.

Table 38: Destinations served from Pakur railway station - Stone chips and aggregate

Sr. No	Destination	Distance from Pakur by Rail (km)	Cargo Distribution (%)	Cargo Volume (tons/day)	Rate per ton-km by Rail (Rs)
1	Patna	376	22.4%	3,077	1.57
2	Ara	425	12.4%	1,710	1.47
3	Chhapra	439	18.6%	2,564	1.50
4	Samsi	103	3.1%	427	2.08
5	Sithamarhi	448	12.4%	1,710	1.47
6	Begusarai	304	12.4%	1,710	1.61
7	Kolkata	262	12.4%	1,710	1.62
8	Kidderpore Dock	279	6.2%	855	1.64

Source: Consultants' Market Survey, August-October 2015

Coal loaded at Pakur railway station is for operation of the thermal power stations given in Table 39.

Table 39: Destinations served from Pakur railway station – Coal

Sr. No	Destination	Distance from Pakur by Rail (km)	Cargo Distribution (%)	Cargo Volume (tons/day)	Rate per ton-km by Rail (Rs)
1	Ropar Thermal Power Plant, Rupnagar (RTPP)	1,570	27.4%	5,492	1.35
2	Guru Hargobind Thermal Power Plant, Lehra, Mohabbat (GHTL)	1,637	36.1%	7,226	1.39
3	Guru Nanak Thermal Power Plant, Bathinda (GNTB)	1,662	11.5%	2,315	1.37
4	Bakreshwar Thermal Power Station, Udaipur, West Bengal (BTPS)	116	25.0%	1,002	1.78
5	Sagardighi Thermal Power Plant Siding, Manigram, West Bengal (PSPM)	95		1,002	2.17
6	Kolaghat Thermal Power Station, Mecheda (KPPS)	310		1,002	1.53
7	Durgapur Coke Oven Plant Exchange Yard, Waria, Durgapur, West Bengal (DCOP)	171		1,002	1.65
8	Santaldih Thermal Power Station, West Bengal. (STPS)	243		1,002	1.56

Source: Consultants' Market Survey, August-October 2015

The amount of coal delivered at the three major thermal power plants during the year 2014-15 is as given below (monthly breakdown see Table 2 of Annex 5):

Loading of Coal (2014-15)	RTPP	GHTL	GNTB
Total (MMT)	0.200	0.264	0.845
Average per day by Rail (tons)	5,492	7,226	2,315

During the year 2014-15, almost 5,500 tons of coal per day were delivered at Ropar Thermal Power Plant, Rupnagar, 7,226 tons of coal per day at Guru Hargobind Thermal Power Plant, Lehra, Mohabbat and 2,315 tons of coal per day were delivered at Guru Nanak Thermal Power Plant, Bathinda.

5.1.2.9 Baghalpur

Cement, Food grains and Fertilizers are the commodities which are unloaded at Baghalpur railway station. The volumes of individual commodities unloaded at Baghalpur railway station during the year 2014-15 is given below (monthly breakdown see Table 4 of Annex 5).

Commodity Unloading (2014-15)	Cement	Rice	Wheat	Fertilizer
Total (MMT)	0.24	0.12	0.09	0.04
Average per day by Rail (tons)	662	321	242	114

It can be seen that during the year 2014-15, 662 tons of cement, 321 tons of rice, 242 tons of wheat and 114 tons of fertilizer per day were unloaded at Baghalpur railway station. Rice and wheat are further transported to Food Corporation of India (FCI) warehouses which are located at a distance of 5-6 km away from the railway station. Likewise, cement is also transported to warehouses which are located at 2-3 km away from the railway station.

The origin of these commodities unloaded at Bhagalpur railway station and the costs involved are given in following Table 40, Table 41, Table 42 and Table 43.

Table 40: Origin of cement unloaded at Bhagalpur Railway Station

Sr. No	Origin	Distance from Bhagalpur-by Rail (km)	Cargo Distribution (%)	Cargo Volume (tons/day)	Rate per ton-km-by Rail (Rs)
1	Akaltara, Chhattisgarh	882	4.5%	30	1.34
2	Ambuja Cement Eastern Ltd, Abada, W.B.	427	1.1%	8	1.44
3	Andal, West Bengal	309	1.1%	8	1.48
4	Bachhrawan, Uttar Pradesh	701	2.3%	15	1.42
5	Baikunth, Chhattisgarh	986	2.3%	15	1.32
6	Baragarh, Odisha	794	1.1%	8	1.33
7	Chunar, Uttar Pradesh	462	1.1%	8	1.40
8	Dalmia cements east limited, Jharkhand	389	1.1%	8	1.42
9	Dhutra, Odisha	694	9.1%	60	1.34
10	Dilwa, Bihar	276	4.5%	30	1.55
11	Durgapur, West Bengal	325	6.8%	45	1.41
12	Jabalpur, Madhya Pradesh	939	1.1%	8	1.32

Sr. No	Origin	Distance from Bhagalpur-by Rail (km)	Cargo Distribution (%)	Cargo Volume (tons/day)	Rate per ton-km-by Rail (Rs)
13	Jahangirabad, Uttar Pradesh/J P Bela Siding	779	8.0%	53	1.36
14	Jalalpur Mandwa	2,081	1.1%	8	1.17
15	Jamshedpur, Jharkhand	472	4.5%	30	1.37
16	Jaypee,Rewa, Madhya Pradesh	698	9.1%	60	1.33
17	Jinkhpani, Jharkhand	518	3.4%	23	1.43
18	JP Rewa cement siding, TZR	776	5.7%	38	1.36
19	M/s Bhilai Jaypee cement limited, Chhattisgarh	1,042	2.3%	15	1.37
20	M/s Lafarge India Pvt Ltd, West Bengal	336	3.4%	23	1.46
21	M/S. Jaiprakash Associates, Chunar	467	1.1%	8	1.38
22	Marauda, Chhattisgarh	1,052	1.1%	8	1.36
23	Muktsar, Punjab	1,560	1.1%	8	1.31
24	New Guwahati, Assam	822	3.4%	23	1.36
25	New Jalpaiguri, West Bengal	192	1.1%	8	1.58
26	Rajgangpur, odisha	632	9.1%	60	1.37
27	Raniganj, West Bengal	316	1.1%	8	1.45
28	Sahibganj	74	2.3%	15	2.68
29	Sindri Town	351	2.3%	15	1.48
30	Sitapur City, Mordabad	781	1.1%	8	1.35
31	Tildanga, West Bengal	138	1.1%	8	1.75
32	Ultratech Cement Ltd, Chhattisgarh	986	1.1%	8	1.32

Source: Consultants' Market Survey, August-October 2015

Table 41: Origin of rice unloaded at Bhagalpur Railway Station

Sr. No	Origin	Distance from Bhagalpur-by Rail (km)	Cargo Distribution (%)	Cargo Volume (tons/day)	Rate per ton-km-by Rail (Rs)
1	Ambala, Punjab	1,303	2.3%	7	1.28
2	Baghbara, Chhatisgarh	1,051	2.3%	7	1.26
3	Bariwala, Punjab	1,545	2.3%	7	1.23
4	Barnala, Punjab	1,439	4.7%	15	1.24
5	Bhabua, Bihar	378	2.3%	7	1.28
6	Bhatapara, Chhattisgarh	955	2.3%	7	1.27
7	Bhatinda, Punjab	1,487	7.0%	22	1.20
8	Dhuri, Punjab	1,409	2.3%	7	1.27
9	Faridkot, Punjab	1,540	2.3%	7	1.23
10	Firozpur, Punjab	1,543	2.3%	7	1.23
11	Gaya, Bihar	227	2.3%	7	1.49
12	Giddarbaha, Punjab	1,513	2.3%	7	1.25
13	Goniana, Punjab	1,497	2.3%	7	1.19
14	Hodal, Faridabad, Haryana	1,122	2.3%	7	1.28
15	Jakhal, Haryana	1,389	4.7%	15	1.20
16	Jalalabad, Punjab	1,596	2.3%	7	1.19
17	Jivanti, West Bengal	241	2.3%	7	1.41
18	Karnal, Haryana	1,312	2.3%	7	1.27
19	Khanna, Punjab	1,374	4.7%	15	1.22

Sr. No	Origin	Distance from Bhagalpur-by Rail (km)	Cargo Distribution (%)	Cargo Volume (tons/day)	Rate per ton-km-by Rail (Rs)
20	Kotkapura, Punjab	1,527	2.3%	7	1.24
21	Lehra Gaga, Sangrur, Punjab	1,405	2.3%	7	1.27
22	Moga, Punjab	1,485	7.0%	22	1.20
23	Mughal Sarai, Uttar Pradesh	430	2.3%	7	1.33
24	Muktsar, Punjab	1,560	9.3%	30	1.22
25	Nabha, Punjab	1,382	2.3%	7	1.21
26	Patiala, Punjab	1,336	2.3%	7	1.25
27	Pinjrapol BH	315	2.3%	7	1.35
28	Raipur, Chhattisgarh	1,031	2.3%	7	1.29
29	Rure Asal, Punjab	1,564	2.3%	7	1.21
30	Sainthia, West Bengal	236	2.3%	7	1.44
31	Sarna, Punjab	1,588	2.3%	7	1.19
32	Sunam, Punjab	1,427	2.3%	7	1.25
33	Yamunanagar, Haryana	1,252	2.3%	7	1.24

Source: Consultants' Market Survey, August-October 2015

Table 42: Origin of wheat unloaded at Bhagalpur Railway Station

Sr. No	Origin	Distance from Bhagalpur-by Rail (km)	Cargo Distribution (%)	Cargo Volume (tons/day)	Rate per ton-km-by Rail (Rs)
1	Abohar, Punjab	1,558	6.5%	16	1.22
2	Ahmedgarh, Punjab	1,442	6.5%	16	1.24
3	Ambala, Punjab	1,303	3.2%	8	1.28
4	Bareta, Punjab	1,403	3.2%	8	1.27
5	Bhattu Kalan, Haryana	1,415	3.2%	8	1.26
6	Bhuchchu, Punjab	1,487	3.2%	8	1.20
7	Bolinna Doaba, Punjab	1,474	3.2%	8	1.21
8	Chheharta, Punjab	1,559	6.5%	16	1.22
9	Chongajan, Assam	1,088	3.2%	8	1.22
10	Fazilka, Punjab	1,608	3.2%	8	1.18
11	Firozpur, Punjab	1,543	3.2%	8	1.23
12	Jagraon, Punjab	1,456	3.2%	8	1.23
13	Jakhal, Haryana	1,389	3.2%	8	1.20
14	Jind, Haryana	1,321	3.2%	8	1.27
15	Mandi Gogindgarh, Punjab	1,366	3.2%	8	1.22
16	Muktsar, Punjab	1,560	3.2%	8	1.22
17	Narwana, Haryana	1,351	3.2%	8	1.24
18	Panipat, Haryana	1,278	3.2%	8	1.22
19	Patiala, Punjab	1,356	3.2%	8	1.23
20	Patti, Punjab	1,596	6.5%	16	1.19
21	Pehowa Road, Haryana	1,369	3.2%	8	1.22
22	Rampura Phul, Punjab	1,472	3.2%	8	1.21
23	Sangrur, Punjab	1,425	3.2%	8	1.25
24	Sulthanpur Lodhi, Punjab	1,500	3.2%	8	1.19
25	Talwandi Bhai, Punjab	1,509	3.2%	8	1.26
26	Tarn Taran, Punjab	1,575	3.2%	8	1.20
27	Uchana, Haryana	1,336	3.2%	8	1.25

Source: Consultants' Market Survey, August-October 2015

Table 43: Origin of fertilizer unloaded at Bhagalpur Railway Station

Sr. No	Origin	Distance from Bhagalpur-by Rail (km)	Cargo Distribution (%)	Cargo Volume (tons/day)	Rate per ton-km-by Rail (Rs)
1	Baneshwar, West Bengal	544	7.7%	9	1.27
2	Bareilly, Uttar Pradesh	958	7.7%	9	1.26
3	Kakinada Sea ports limited	1,417	7.7%	9	1.26
4	Meerut, Uttar Pradesh, TCL Siding	1,055	7.7%	9	1.26
5	Paradip	892	23.1%	26	1.23
6	Phulpur, Uttar Pradesh	551	23.1%	26	1.36
7	Tata Chemicals Ltd, West Bengal	535	15.4%	18	1.29
8	Vijaipur, Madhya Pradesh	1,246	7.7%	9	1.25

Source: Consultants' Market Survey, August-October 2015

As an example, an OD-pair is presented in the following: The Consultants have identified 5,000 tons of fertilizer brought by railways from Kakinada Sea Port (Andhra Pradesh) over a distance of more than 1,400 km, a voyage which takes three days. This OD-pair is analyzed further in Chapter 5.3.

Table 44: Feasible cargo OD-pair via Bhagalpur - Fertilizer

Origin	Destination	Transport Mode	Distance [km]	Travel Time Est. [days]	Volume 2014 [tons]
Kakinada Port	Bhagalpur Railway Station	Railway	1,417	3.0	4,988

Source: Consultants' Market Survey, August-October 2015; calculations by Transport Model

5.1.2.10 Kahalgaon

Kahalgaon Thermal Power Station is operated by National Thermal Power Corporation (NTPC) and coal for the thermal power plant is sourced from coal fields at Lalmatiya in Jharkhand, coal fields at Andal in W.B. and imported coal from Thailand dumped at Haldia port. Imported coal from Haldia port is transported by rail to Kahalgaon Thermal Power Station railway siding. The amount of coal unloaded at Kahalgaon Thermal Power Station railway siding during the year 2014-15 is given below:

Coal Unloading (2014-15)	Amount
Total (MMT)	5.963
Average per day by Rail (tons)	16,336

It can be seen that during the year 2014-15 on an average about 16,300 tons of coal was unloaded at Kahalgaon Thermal Power Station.

Furthermore, flyash generated from Kahalgaon Thermal Power Station is loaded at the railway siding and is served to several destinations in the north east, viz Guwahati, Champasari, Digaru and Barpeta Road. It is also transported to Rohanpur in Bangladesh. About 1,733 tons of flyash per day is loaded at Kahalgaon thermal power station railway siding and is served to the destinations given in Table 45.

Table 45: Destinations served from Kahalgaon Thermal Power Station railway siding

Sr. No	Destination	Distance from Kahalgaon-by Rail (km)	Cargo Distribution (%)	Cargo Volume (tons/day)	Rate per ton-km-by Rail (Rs)
1	Guwahati (GHY)	788.27	25.0%	433	1.15
2	Champasari, Siliguri (SGUJ)	387.14	25.0%	433	1.22
3	Digaru (DGU)	821.86	25.0%	433	1.17
4	Barpeta Road (BPRD)	675.85	25.0%	433	1.18

Source: Consultants' Market Survey, August-October 2015

Table 46: Coal provided to Kahalgaon Thermal Power Station railway siding

Sr. No	Destination	Distance from Kahalgaon-by Rail (km)	Cargo Distribution (%)	Cargo Volume (tons/day)	Rate per ton-km-by Rail (Rs)
1	Andal	279	10.0%	1,634	0.00
2	Imported coal at Haldia	511	10.0%	1,634	0.00
3	Lalmatiya	55	80.0%	13,069	4.64

Source: Consultants' Market Survey, August-October 2015

Table 47: Fertilizer provided to Katihar Railway Station

Sr. No	Destination	Distance from Kahalgaon-by Rail (km)	Cargo Distribution (%)	Cargo Volume (tons/day)	Rate per ton-km-by Rail (Rs)
1	Kanpur	839	50.0%	1,300	1.54
2	Vishakapatnam	1,290	50.0%	1,300	1.50
3	Kanpur	839	50.0%	2,600	1.54
4	Vishakapatnam	1,290	50.0%	2,600	1.50
5	Kanpur	839	50.0%	3,900	1.54
6	Vishakapatnam	1,290	50.0%	3,900	1.50

Source: Consultants' Market Survey, August-October 2015

The below figure summarizes the volume significance of the above-discussed commodities in the Farakka-Munger sector.

Figure 40: Commodities moved in Farakka-Munger Sector

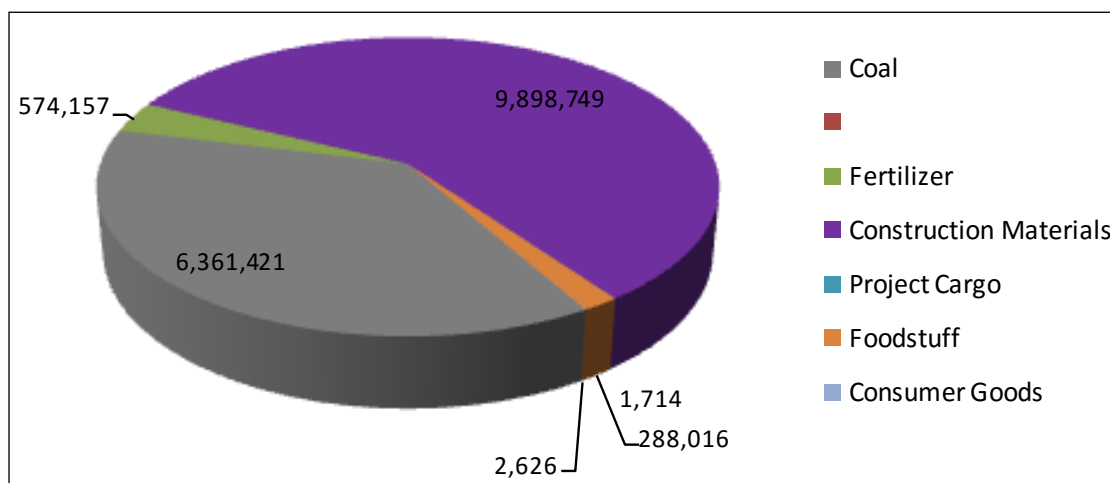

Source: Consultants' Market Survey, August-October 2015

The following table depicts commodities identified by the Consultants' market survey.

Table 48: Commodities by origin and destination in Farakka-Munger sector (tons)

Commodity	Cargo Type	Origin Cargo	Destination Cargo
Coal	Dry bulk	360,150	6,001,271
Sand		94,300	
Natural Aggregates		9,139,200	571,116
Fertilizer	Bagged	99,641	474,516
Cement			94,133
Food Grains		30,800	248,080
Project Cargo	Neo-bulk		1,714
Textiles	General Cargo	2,626	
Food		1,616	7,520
Total		9,728,333	7,398,350

Source: Consultants' Market Survey, August-October 2015

Natural aggregates loaded in the sector constitute the most important commodity, while the area also serves as distribution point for coal. Table 3 of *Annex 5* depicts the origin-destination pairs which had been identified during the Consultants' market survey.

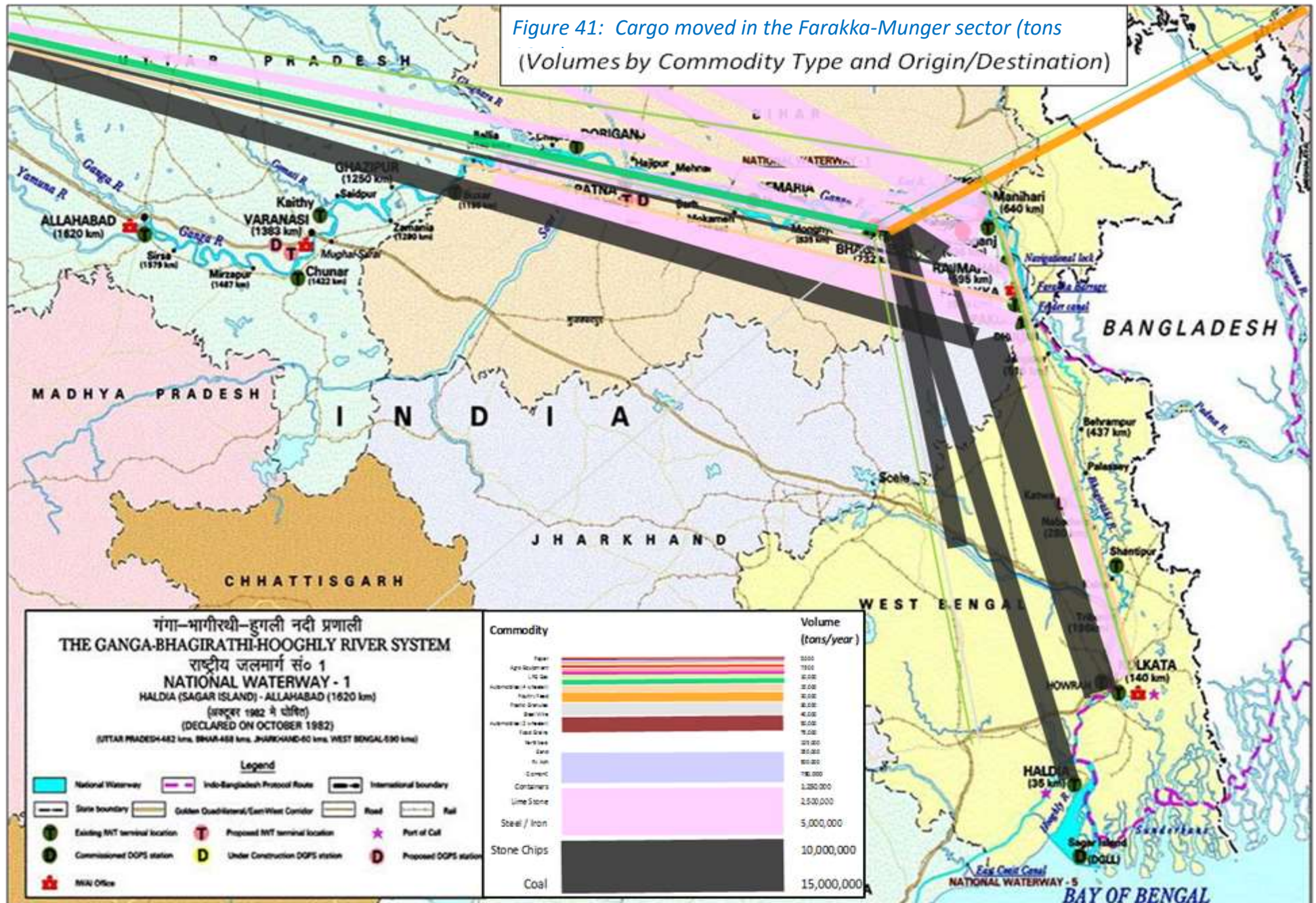

5.1.3 Munger-Ballia sector

The following table depicts commodities identified by the Consultants' market survey.

Table 49: Commodities by origin and destination in Munger-Ballia sector (tons)

Commodity	Cargo Type	Origin Cargo	Destination Cargo
Coal	Dry bulk	314,908	16,196,596
Natural Aggregates			13,918,093
Iron Ore		10,205	
Limestone		1,370,000	
Cement	Bagged	70,000	1,273,500
Fertilizer		25,000	692,225
Food Grains		345,773	1,641,317
Bricks & Tiles	Neo-bulk	10,300,000	
Petroleum		136,296	
Steel		280,300	2,403,174
Agro Equipment			5,143
Project Cargo		130,500	360
Food	General Cargo	646,510	163,448
Other Cargo		500	40,360
Containerized	Container	-	480,000
Total		13,629,992	36,814,216

Source: Consultants' Market Survey, August-October 2015

The area around Patna and eastward is well known for brick burning due to excellent clay deposits. Limestone production is therefore also very significant in this sector.

Figure 42: Commodities moved in Munger-Ballia Sector

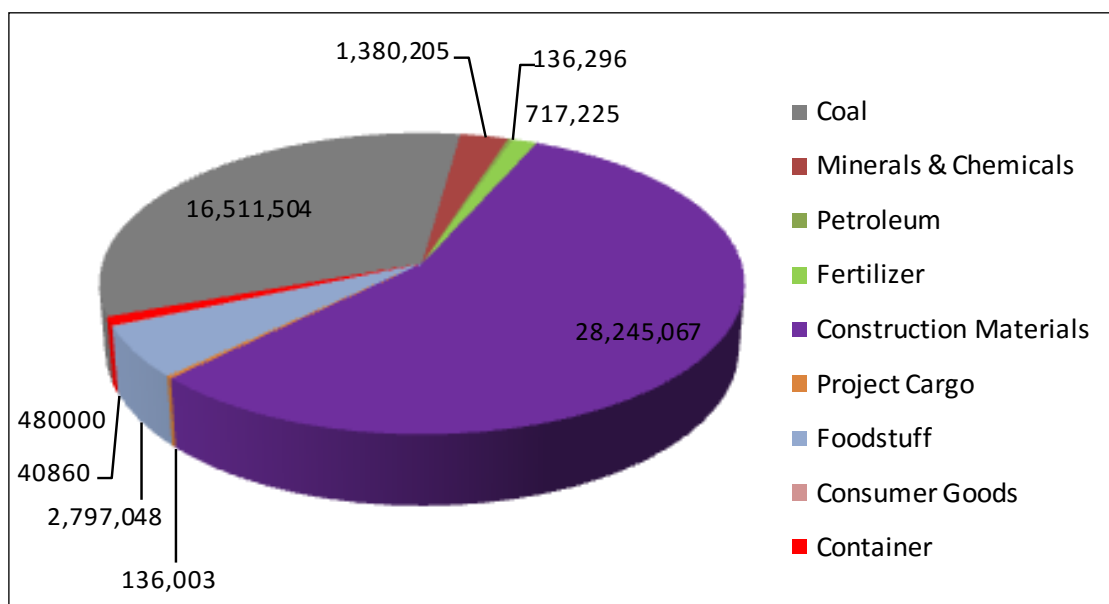

Source: Consultants' Market Survey, August-October 2015

Construction materials constitute the largest proportion of cargo moving through the sector. These cover all forms of cargo types: Natural aggregates and limestone as dry bulk, cement as bagged cargo, and bricks & tiles as neo-bulk cargo.

5.1.4 Ballia-Allahabad sector

5.1.4.1 Coal

Imported high-calorie coal: Bothra Group has a shipping and logistics business, and runs a coal terminal at Kakinada where an average of 2.0 MMT of coal is handled per year.

Domestic low-calorie coal: Every day around 2,000 tons per day (= minimum 100-120 trucks, maximum 200-250 trucks of 10-15 tons each) are trucked to the coal mandi in Varanasi from coal mines of Jharkhand and Madhya Pradesh (MP). This operation is carried out for nine months (not during the three months of the rainy season). Several small coal buyers in Patna area ask for coal transport (about 500 – 1,000 tons per month by barge).

5.1.4.2 Building materials

Cement

Two cement plants are located in the Varanasi region: one of the *Jaypee Group*, the other one of ECO Cements Limited:

1. *Jaypee Plant* produces 2.5 MMT cement per year with destination U.P. and Bihar. The plant is in 9 km distance from the Ganges, 30 km downstream of Varanasi.
2. *ECO Plant* produces 0.9 MMT cement per year for Bihar (70%), W.B. (15%) and U.P. (15%).

Stone chips

Stone chips and sand are presently transported by truck from Sonbhadra in the southwest of Varanasi, but would most possibly be procured from Bihar and Jharkhand (Sahibganj) due to lower rates, if IWT was available on NW-1.

5.1.4.3 Agricultural inputs

Fertilizer (urea)

Fertilizer can be imported at Kakinada port and then transported to Haldia and IW. Trains can carry fertilizer and manually discharge at IWT terminals by means of a conveyor belt to load / discharge.

5.1.4.4 Food grains and flour

Wheat

Grain is transported from U.P. (about 20% of all U.P. wheat) to Bihar and W.B. by Food Corporation of India (FCI).

Rice

About 20% of U.P. rice is transported to Bihar and W.B. by FCI.

5.1.4.5 Edible oil

Crude vegetable oil: Crude vegetable oil can be bound for Nepal if containerized and handled at Varanasi.

5.1.4.6 Local hand-loom silk products

Sarees

Many sarees are high-value home products which could be transported in containers. Volumes generated are 1.2 – 1.5 million Sarees per year => 2,000 tons per year (1 center), corresponding to 150 TEU per day (all centers) of which 30% are transported to U.P., Bihar and W.B. Additional incoming containers could carry inputs, such as silk from China (importers in Kolkata need to be questioned). However, transport chains still need to be established (particularly shipping to/from Kolkata/Haldia) => projected for the year 2028.

Carpets

Presently, 90% (of minimum 130,000 tons per year) of local carpets are transported on road to Mumbai. Carpets represent a major containerizable product. Estimated at 20 tons per TEU, 6,500 TEU would be moved annually. In fact, initially an ICD 30 km down the river was geared for carpets, but the trade did not work (due to missing transport chain?). In case, carpets went via the NW-1 then for onward transport through Haldia or Kolkata port on feeders, this business could be shared by local shipping agents. Bothra tried for containers earlier, but it did not work out.

5.1.4.7 Over-dimensional cargo (ODC)

In 2014, *Prism Logistics* carried 325 tons of heavy equipment on barge from Haldia to Allahabad. This company handles only ODC. *Eastern Navigation* is a shipping company focusing on ODC cargo and technical support vessel/facilities like pontoons, bridge construction facilities, etc. The company aims at earnings of around Rs 25 million per vessel trip (ODC cargo).

The below *Figure 44* summarizes the volume significance of the above-discussed commodities in the Ballia-Allahabad sector.

Figure 43: Commodities moved through Ballia-Allahabad sector (tons)

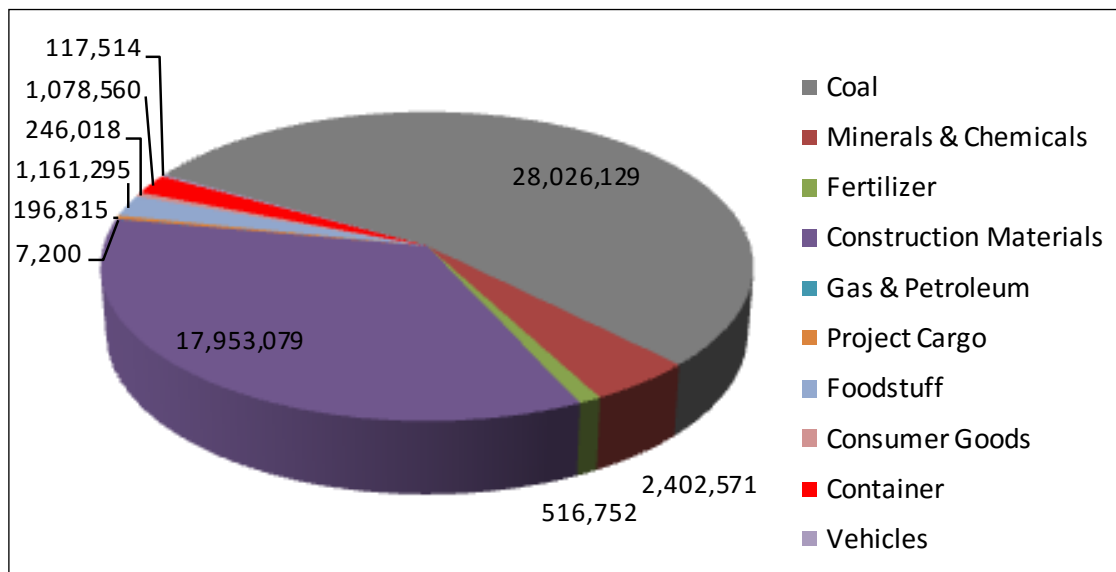

Source: Consultants' Market Survey, August-October 2015

The following table depicts commodities identified by the Consultants' market survey.

Table 50: Commodities by origin and destination in Ballia-Allahabad sector (tons)

Commodity	Cargo Type	Origin Cargo	Destination Cargo
Coal		18,810	28,007,319
Limestone	Dry bulk	2,400,000	2,571
Natural Aggregates		-	89,166
Gas & Petroleum	Liquid bulk	-	7,200
Fertilizer		372,752	144,000
Cement	Bagged	1,981,169	236,400
Food		777,615	-
Bricks & Tiles		-	10,400,000
Steel	Neo-bulk	13,124	5,233,220
Project Cargo		360	196,455
Textiles		5,475	94,363
Food	General Cargo	320,080	63,600
Other Cargo		98,480	47,700
Containerized	Container	17,280	1,061,280
Vehicles	Ro-ro	117,514	-
Total		6,122,659	45,583,274

Source: Consultants' Market Survey, August-October 2015

Significant amounts of coal are brought to Allahabad and Varanasi for onward distribution to TPPs. Much of the limestone being mined in this area is transported eastwards for brick-burning. In exchange, bricks are being brought for the significant construction activities in this sector.

5.2 Bottlenecks by transport mode and route

5.2.1 Railways

There are some sections where IR has been working above their capacity, especially on the eastern corridor line Delhi–Howrah. Currently, these routes face 140-150% of capacity utilization. Generally, a rail route is considered congested when the capacity utilization increases above 80%.

Over-saturation has implications for the quality of service of freight trains and severely restricts IR's ability to meet customer expectations. Speed of freight trains has largely remained stagnant and improved only marginally from 25 to 29 km per hour over the last three decades – as against a design average speed of 60 km/hour. These capacity constraints need to be further viewed in the context that IR does not operate heavy-haul freight trains which imply higher cost-efficiency in freight operations. Furthermore, the infrastructure is used by both, passenger and freight trains. The maximum gross load carried on trains of IR is 5,400 tons, compared to 20,000-37,000 tons in China, South Africa, Brazil and Australia. This may change only when the EDFC gets operational, as trains with maximum gross load of 12,000 tons are expected to run on this DFC. Also, the parcel size of cargo is presently restricted between the range of 2,400 metric tons and 3,800 metric tons and, therefore, cuts out many customers even in the bulk-cargo segment. Given the above constraints, IR has focused on carrying bulk cargo in train-loads dominated by a limited number of nine commodities such as coal (46%), iron ore (13%), cement (11%), fertilizers (5%) steel (5%), raw materials for steel plants (5%) except iron ore, food grains (5%), petroleum products (4%) and container traffic (4%), plus others (2%).

Ideally, coal and iron ore are supposed to be trucked by road only on short distances, mainly from the mines to the rail sidings. Feeder rail routes would then carry the coal or iron ore from the rail sidings to the trunk routes. The trunk routes would carry the minerals long distances, usually between distant states. Close to the destination, feeder routes would finally move the materials from the trunk route to the rail siding at the power or steel plant. However, the Consultants' market survey established that large volumes are being trucked over large distances, for instance coal and steel from Howrah Goods Yard at Kolkata to Patna or even Allahabad, coal from Shalimar Junction to Varanasi Junction, with limestone being trucked in the opposite direction, and again coal from Pakur to Kolaghat or Sagardighi (both in West Bengal), and stone chips from Nalhati and Pakur to Kolkata.

Although mining activities are concentrated in a number of locations, this comparatively low density may also be a reason why several mining products, like stone chips and coal, are in their majority trucked via Jharkhand's roads instead of being loaded onto trains.

5.2.2 Roads

Traffic on Indian roads is highly concentrated along certain corridors that link the largest metropolitan cities. The infrastructure and availability of services along these corridors is comparatively superior to that connecting with the more minor urban centers. A common complaint from the users is the absence of last-mile links. Ports connect insufficiently with the rail and road networks. The rail and road networks do not offer efficient points of interchange

for each to be harnessed to its best advantages, resulting in suboptimal energy usages and higher costs as rail's last-mile disadvantages prove debilitating.

Of the four riparian states, Jharkhand is in a special position: Road density in terms of both surface area as well as population is very low compared to the other three states and to India as a whole (see *Chapter 2.1.6*). Despite this low density, almost one in ten inhabitants owns a vehicle – perhaps due to the long distance to central places.

Of the few roads in Jharkhand, most are surfaced (asphalt or concrete). This is also reflected in the two tables below indicating that density of roads other than national (NH) and state (SH) highways is extremely low in terms of both surface area and population. At the other end of the scale ranks West Bengal which is comparably well endowed with roads, although mostly non-surfaced.

Table 51: Total road length of NW-1 riparian states versus national (km/'000 km²)

State/U.T.	NH	SH	Others	Total
Bihar	38.7	40.0	1196.6	1275.2
Jharkhand	22.6	23.6	173.0	219.1
Uttar Pradesh	24.4	34.8	1122.0	1181.2
West Bengal	28.4	18.9	2332.2	2379.4
India	20.3	47.0	847.6	914.9

Source: Statistical Abstract, Census of India 2011

In terms of national and state highways, Bihar has the densest network of the four riparian states, comparable to India as a whole.

Table 52: Total road length of NW-1 riparian states versus national (% km/'000 heads)

State/U.T.	NH	SH	Others	Total
Bihar	0.04	0.04	1.09	1.16
Jharkhand	0.05	0.06	0.42	0.53
Uttar Pradesh	0.03	0.04	1.35	1.43
West Bengal	0.03	0.02	2.27	2.32
India	0.06	0.13	2.30	2.49

Source: Statistical Abstract, Census of India 2011

However, density of the road network does not give any indication of its condition. The road network suffers from deficiencies in terms of pavement thickness, distressed bridges, etc. Total transport costs - road user costs plus road agency costs of construction, maintenance and rehabilitation - are minimized at an axle load of 11 tons. However, approximately 80-90% of the national and state highways are not suitable for the permissible axle loads of 10.2 tons. Massive investments are needed to strengthen the network for the currently prescribed axle loads. In summary, not only the quantity but also the quality of roads and bridges needs considerable improvement.

Light trucks and double-axle trucks dominate the Indian trucking industry, as narrow and badly maintained roads have traditionally permitted only the use of smaller and more flexible vehicles, and as regulations prohibiting the overloading of vehicles have been poorly enforced. The small vehicle sizes and widespread overloading mean that Indian trucking costs are

amongst the lowest for bulk and heavy goods, but the cost for relatively lighter products — electronics, pharmaceuticals, chemicals, etc. — is substantially higher.

5.2.3 National Waterway No. 1

Major constraints against connecting potential NW-1 users were expressed during the Consultants' market survey. The following constitutes a summary of interviewees' comments:

- Present mode of water transport is by coastal vessel, as neither river-sea vessels nor inland-waterway barge services are available on the NW-1;
- Insufficient road and rail connectivity to the plant and availability of service;
- High cost of transportation besides availability of service and reliability on the NW-1;
- Logistical bottlenecks, connectivity and infrastructure;
- Non availability of infrastructure and services;
- Inland waterways are more circuitous than roadways and railways;
- Insufficient draft in the river;
- Absence of mechanized loading and unloading in the terminals;
- Involvement of multi-modal transportation, thus broken traffic;
- Absence of both-way cargo;
- Absence of easy bank-loan facilities for new ship-building in comparison to availability of "house loan", "car loan" etc.
- Absence of tonnage tax on barges registered under I.V. Act 1917. There was a tax benefit available under Section 33 AC of Income Tax Act 1961 for all the ships, which include barges and even pontoons. This section had been scrapped with effect from year 2005-06, denying benefit to barges registered under I.V. Act 1917. From year 2005-06, tonnage tax was introduced under u/s 115V to 115VZC in I.T. Act 1961, whereby ships registered under the M.S. Act were given the benefit of lower tax.⁴⁷
- Presence of waterway charges: Using free-flowing water should not attract any charges. Maintaining navigability of the river is like maintaining a road which users do not pay any direct charges for. This is a hindrance for waterways to develop and to compete with other modes. In case the authority created any infrastructure, then it could charge users for using the same.

The following list indicates the prioritized needs of the interviewed market actors as prerequisite for using the NW-1:

This was stated by Mr S. Rakshit of the inland-barge operator Vivada Corporation Pvt Ltd in Kolkata (contact: cell 09903000269, vivadakolkata@yahoo.co.in)

- Adequate water depth with a guaranteed LAD maintained throughout the year;
- Stable and preferably buoyed channels with a width of at least 60 meters;
- Dredging, modern river information system (RIS), digital global positioning system (DGPS), night navigation facilities and modern methods of channel marking;
- Freight tariff rates cheaper than alternative transport modes;
- Adequate night navigation facilities;
- Adequate amount of storage space - both covered and open with modern mechanical handling facilities (particularly for container and bulk handling);
- Multi modal terminals with adequate facilities for handling all different commodities without disturbing each other;
- Channel marking and other clearance issues associated with the investing process;
- Absence of local (especially while crossing the state of Bihar) and political disturbances;
- Ro-ro facilities for heavy lift / ODC and automobiles;
- River bank (both sides) risen onto an embankment by compacted soil;
- Integration of coastal and inland waterways;
- Documentation for EXIM cargo at inland terminals.

5.3 Examination of origin-destination pairs

Origin-destination pairs, which the Consultants during their market survey identified as commodity transport feasible for being diverted onto the NW-1 (for a description of the individual commodities see previous *Chapter 3.5*), were further analyzed by their Transport Model. *Table 53* overleaf depicts the 20 important commodities transported within the NW-1 catchment area, which could be most profitably shipped on the NW-1, their origins and destinations, and their most significant parameters and associated costs.

Table 53: Important commodities divertible onto NW-1 as identified through the Consultants' market survey

Commodity Type	Cargo Type	Current Transport Mode	Origin	Destination	Distance [km]	Estimated Travel Time [days]	Volume 2014 [tons]	Growth expected by Producer (%)	Freight Costs per ton per km [Rs/ton/km]	Freight Rate [Rs/ton]	Value of Time [Rs/ton]	Generalised Cost [Rs/ton]
Coal	Dry Bulk	Road	Haldia HDC	Partapgarh	941	2.0	30,000	8	6.50	6,116.5	3.4	6,119.9
Fly Ash		IWT	Durgapur (W.B.)	Narayanganj/Bangladesh	925	5.5	807,000		1.12	1,036.0	11.8	1,047.8
Iron Ore		Rail	Barauni (Bihar)	Haldia	574	1.2	10,200	10	2.18	1,251.3	2.6	1,253.9
Lime Stone		Road	Kolkata	Allahabad	800	1.7	2,571	5	3.00	2,400.0	6.6	2,406.6
Sand		Road	Mangalhat	Kolkata	352	0.7	73,500		3.45	1,214.4	2.9	1,217.3
Stone Chips		Road	Sakrigali	Gauthamsthan, Bihar	389	0.8	179,200		3.45	1,342.1	3.2	1,345.3
Plastic Granules	Bagged	Road	Kanpur (U.P.)	Kolkata	1,160	2.4	6,300	5	3.65	4,234.0	5.2	4,239.2
Grain		Road	Fatuwa	Haldia	628	0.9	50,000	0	4.00	2,512.0	104.7	2,616.7
Cement		Road	Varanasi	Patna	269	0.6	1,000	10	4.20	1,129.8	2.2	1,132.0
Fertilizer		Rail	Vishakapatnam	Katihar Railway Station	1,290	2.7	23,400		1.50	1,935.0	20.1	1,955.1
Steel	Neo-bulk	Road	Fatuwa	Kolkata	536	0.7	150,000		4.00	2,144.0	44.7	2,188.7
Petroleum		Rail	Numaligarh/Assam	Haldia	1,442	3.0	24,138	10	2.57	3,705.9	6.4	3,712.4
Logs & Wood		Road	Faizabad	Kolkata	878	1.8	3,120	10	3.30	2,897.4	7.3	2,904.7
Textiles		Road	Kolkata	Sultanpur	830	1.7	7,200	3	5.00	4,150.0	74.7	4,224.7
Project Cargo		Road	Fatuwa	Kolkata	536	0.7	80,000		4.00	2,144.0	357.3	2,501.3
Statues		Road	Chunar	Kolkata	692	1.4	40,000	5	4.90	3,390.8	62.3	3,453.1
Paper		Road	Karnataka	Kolkata	2,200	4.6	4,286	5	3.60	7,920.0	198.0	8,118.0
Food	Gen. Cargo	Road	Kolkata	Allahabad	790	1.6	8,400	5	7.00	5,530.0	10.6	5,540.6
Containers	Container	Road	Kolkata	Varanasi	582	1.2	972,000	10	10.52	6,120.5	104.8	6,225.2
Vehicles	Ro-Ro	Road	Delhi	Kolkata	1,500	3.1	27,000	5	46.67	70,005.0	333.9	70,338.9

Source: Consultants' Market Survey, August-October 2015

The volume of selected commodities transported over the year varies between 1,000 tons and almost 1 MMT, some of which are being moved in small parcel sizes on voyages spread over the entire year.

At present, all commodities of the selected O/D pairs – with exception of fly ash – are being transported on land. Vehicles and general cargo, both in break-bulk form or containerized, but also most bagged and neo-bulk cargoes are being trucked on road. Except for three O/D pairs, the main bulk of the selected commodities is trucked on road over distances which are only somewhat shorter than those covered by rail transport. Specific commodities such as vehicles, but also rolled paper and bagged plastic granules, are being trucked over distances exceeded 1,000 km. Even low-value commodities (usually cargoes predestined for IWT) such as coal and lime stone are being trucked over long distances. The average distance between origin and destination of the individual commodities equals to approximately half the length of the NW-1.

Travel times are estimated to usually sum upto more than one day, they average two days, and for one fourth of the selected O/D pairs they exceed this average up to a travel time almost at par with the 5.5 days required by barging fly ash into Bangladesh.

Except for very specific commodities transported on an ad-hoc basis, such as project cargo, and where cargo owners or transport operators were unsure about future demand, most interviewees expected a demand growth between 5% and 10% per annum for the short to medium term.

Freight costs (on a ton-km basis) of land-based transport are approximately double those of IWT, with a significant cost difference between road and rail transport only for higher-value commodities which also require specific (un)loading procedures, such as vehicles and project cargo, but also palletized textiles, breakable statues and bundled steel rods.

Value of time (defined as the interest on the investment into the commodity itself during the duration of any voyage) generally remains below 2% of the freight price.

In a sum, aggregated (generalized) costs (on a per-ton basis) for a voyage remain below Rs 10,000, with the significant exception of vehicles where generalized) costs amount to seven times that level.

6 General Competitiveness of IWT

Within the framework of the Market Development Study and as a part of the Market Survey, this chapter looks into the competitiveness of IWT in comparison to road and rail transport in general and with a special focus on India's NW-1.

6.1 Supply chain review

Supply Chain Management (SCM) can be divided into three main areas: purchasing, manufacturing, and distribution. From end to end, this includes decisions about which input materials to use, production quantities, inventory levels, distribution network configuration, and transportation for the input materials as well as for the finished products. Logistics Management is the component of SCM that focuses on how and when to get these from their respective origins to their destinations. It also includes coordination and collaboration with channel partners, which can be suppliers, intermediaries, third-party service providers, and customers. In essence, SCM integrates supply and demand management within and across companies, and can be a real point of competitive differentiation.

For an effective, cost efficient Logistics Management, a company must lay the foundation for a responsive, economical transportation network. By that, the company is able to implement major strategic changes to reduce costs and increase customer service levels with very little disruption to the overall supply chain flow.

Figure 44: Supply chain

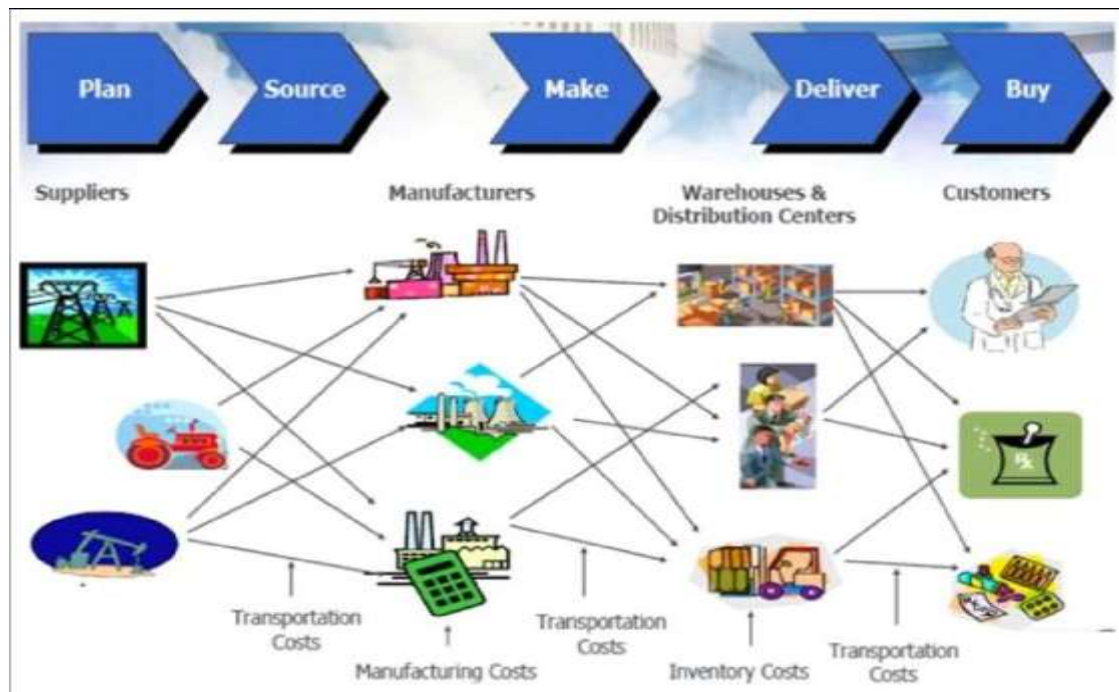

Source: <http://ashasmartimeneews.blogspot.de/2012/04/supply-chain-in-container.html>

Transportation and logistics related costs as a percentage of sales range from 9% to 14% depending on the industry sector. This range includes all logistics related expenses such as warehousing, dedicated personnel, and transportation expense. Transportation costs alone comprise the vast majority of this expense for most companies, amounting up to 30-60% of the logistics operations costs.

During the 1990s and early 2000s, the high availability and low cost of transportation services relative to the cost of keeping inventory encouraged companies to emphasize fast, frequent delivery to customers through means such as just-in-time delivery. However, things have changed in the last decade, especially due to volatile (and for a long time rising) oil prices as well as an imbalance of supply and demand for freight transport services. This has led to increasing transportation costs, high enough to cause companies to make transport-driven shifts in their supply chain strategies.

The first shift considers the sourcing strategies away from long distance shipments. The second is a shift from designing products and packaging for marketability and more efficient production toward designs that also incorporate "shipability" considerations, i.e. focuses e.g. on dimensions for space efficiency and easy handling, providing protection of goods in transit, like through the use of intermodal units. The third is a shift from lean inventory strategies to hybrid lean inventory/transportation strategies, i.e. instead of using just-in-time deliveries by road transport, now IWT is considered an alternative where the –albeit slower – vessel is part of the inventory and transportation strategy. Even though oil prices have come down again, which again makes road transport more feasible, the changes that were made may be a good long term precaution against price changes and other risks in the supply chain and may support the use of IWT transport.

There are two key players in any transportation process within a supply chain. The shipper is the one who requires the movement of the product between two points in the supply chain and uses transportation to minimize the total cost (transportation, inventory, information, and facility) while providing an appropriate level of responsiveness to the customer. The carrier is the one that actually transports the product and makes investment decisions regarding the transportation means (rails, locomotives, trucks, ships, airplanes) and then makes operating decisions to try to maximize the return from these assets.

Mode selection is based on the relative strengths of each modal/intermodal option in terms of accessibility, transit time, reliability, safety and security, transportation cost, and the nature of the product being transported. The carrier's choice focuses on the type of service required (direct or indirect), geographic coverage, service levels, and the carrier's ability and willingness to negotiate reasonable rates.

From a supply chain perspective, the main reason for using inland waterways as a mode of transport is the fact that it decreases the total cost, when used as part of the end to end logistical requirement of cargo movement. The closer the origin and/or destination of the shipment to the waterway, the higher the advantage for IWT compared to other modes of transport. Along the NW-1 corridor several users have been identified that have potential to use IWT for their commodity transports; however, while many industries are located near waterways for convenience of water use, the actual use of waterways for transport is still

- Customers with regular demand, like power plants requiring coal or regular shipments of construction materials;
- Customers with seasonal demand, like food grains and fertilizers;
- Project-based demand, like construction material and equipment related to particular projects as e.g. new thermal plants along NW-1, which often includes over-dimensional cargo;
- Import/export traffic through the main ports offer a potential for onward transports, like intermodal transport of containers.

During the stakeholder interviews it became clear that the majority of companies has organized their transport chains based on truck transportation with some shares for rail transport. However, all expected rising transport volumes in the next years and would be interested in integrating IWT via NW-1 in their transport chains, provided a reliable and cost effective service is offered. For example, the edible oil industry has already prepared supply chain schemes considering the use of IWT as they see potential advantages with regard to shifting customs clearance from the seaports to the inland ports of destination.

In general, changes in the supply chain organizations will only happen if certain prerequisites are fulfilled, namely navigability and infrastructure availability, service reliability, and not at least cost competitiveness.

6.2 Cost competitiveness of IWT compared to road and rail

As mentioned in the previous sub-chapter, there are two key players in the transportation process that deal with different cost components. A carrier, like an inland shipping company, a rail or trucking company, has to take into consideration the following costs:

- Vehicle related costs, i.e. the investment in the transport vehicle (barge, wagon, truck) as well as interests, leasing and depreciation. These costs are fixed as they incur independent of the actual operation, at least in the short term. With regard to medium to long-term planning decisions these costs are variable depending on the number of vehicles acquired.
- Fixed operating costs, i.e. any expenses in relation to terminals and labor independent of the actual vehicle operation. For operational decisions these costs are fixed, while for planning decisions concerning the location and size of facilities these costs are variable. In general, these costs are proportionately to the size of the operating facilities.
- Trip related costs, i.e. basically for labor and fuel as well as maintenance and repairs incurring for each trip independent of the quantity transported. These costs depend on the length and duration of the trip.
- Quantity related costs, i.e. the loading/unloading costs and the part of the fuel costs that varies with the transport volume.

- Overhead costs, i.e. the costs of planning and scheduling a transportation network as well as investments in information technology, like e.g. routing software.

A carrier's decisions are also affected by the responsiveness he seeks to provide his target segment and the prices the market will bear. For example, a carrier may use a hub-and-spoke system for providing fast and reliable delivery times while another may use the direct transport to provide cheaper transportation with longer delivery times. The difference between the two systems is reflected in the pricing schedule. From a supply chain perspective, a hub-and-spoke network is more appropriate when prices are independent of destination and fast delivery is important, whereas a direct delivery is more appropriate when prices vary with destination and a somewhat slower delivery is acceptable.

For the other key player in the transportation chain, shippers' decisions include the design of the transportation network, the choice of means of transport, and the assignment of each customer's shipment to a particular means of transport. A shipper's aim is to minimize the total cost of fulfilling a customer's order, while achieving the assured responsiveness. A shipper has to take account of the following costs when making transportation decisions:

- Transportation costs, i.e. the total amount paid to the various carriers for transporting products to customers. These depend on the prices offered by the different carriers and the extent to which the shipper uses cheaper but slower or expensive but fast means of transportation. Transportation costs are considered variable for planning and operational decisions as long as the shipper does not own the carrier.
- Inventory costs, i.e. the costs of holding inventory incurred by the shipper's supply chain network.
- Facility costs, i.e. the costs of various facilities in the shipper's supply chain network; this includes the direct warehousing costs for rent or investment in real estate, personnel, storage equipment (e.g. for forklifts, shelves, conveyor belts, etc.), energy, and other (e.g. for facility management or building insurances)
- Processing costs, i.e. the costs of organizing loading/unloading orders as well as other processing costs associated with transportation.
- Service level costs, i.e. the costs of not being able to meet delivery commitments. These may sometimes be clearly specified as part of a contract while in other cases it may be reflected in customer satisfaction.

A shipper needs to make a trade-off between all these costs when making transportation decisions. Furthermore, his decisions are also impacted by the responsiveness he seeks to provide his customers and the margins generated from different products and customers. For example, a shipper promising delivery within a certain time window specified by the customer will require different or more means of transport than a shipper whose customer is willing to accept delivery at any time.

An analysis in the EU⁴⁸, which can also be generalized to other countries, has shown that the cost structure for road, rail and inland waterway transport is similar. The labor costs have the highest share, followed by fuel, capital costs, taxes and insurances, and administration costs. In road transport the labor costs stand for the overwhelming majority, while in rail transport fuel, capital, and maintenance costs play an almost equal role. In IWT the cost structure focuses again on labor and fuel costs. Details with regard to the NW1 cost structure are included in the assumptions made for the transport model (see *Chapter 10.1*).

In India, the prevailing mode of transport is the truck and the share of rail in freight and passenger traffic has been declining over the years. The reasons are pricing policies and non-pricing attributes of the two modes. Rail transport is a state-owned monopoly subject to price regulation. The pricing system for rail transport covers all costs, including that of the fixed infrastructure. Furthermore, there is no distinction between the freight and passenger segments, which leads to considerable cross-subsidization.

Road transport on the other hand is a privatized market competing for freight traffic and the prices of freight transport by trucks are determined by the free market. However, passenger road transport is carried out under a regime of price regulation for both, private and public operators. Road pricing does not reflect the total costs for fixed infrastructure and its maintenance. Besides, the road and fuel taxes have hardly any relation to the resource costs of various inputs. In road transport, the freight and passenger segments operate as independent entities so that there is no element of cross subsidization.

Indian trucks are usually all-purpose, used for transporting everything from agricultural produce to steel products to higher-value electrical items. Poor maintenance and low-quality spare parts rapidly reduce operational efficiency of trucks. Light trucks and double-axle trucks dominate the Indian trucking industry as narrow and badly maintained roads are better only used with smaller and agiler vehicles, and as regulations prohibiting the overloading of vehicles have been poorly enforced. The small vehicle sizes and rampant overloading mean that Indian trucking costs are amongst the lowest for bulk and heavy goods, but the cost for relatively lighter products, electronics, pharmaceuticals, chemicals, etc., is substantially higher.⁴⁹

In the absence of more flexible practices, customers usually engage point-to-point trucking services on a full-load basis. Further inefficiencies sometimes result, when for short to medium-haul distances trucks are forced to return to their base without a load. In total, the industry is strongly competitive with low barriers to entry for either operator or driver, a high degree of substitutability, and significant bargaining power vested with the purchasers of trucking services. The capital required to enter the market is small, the licensing regime is not exceedingly strict, and only basic skills and qualifications are necessary.

The high degree of competition within the trucking industry puts pressure on the prices charged. Margins are recovered by cutting costs, such as by hiring drivers with suspect licenses, by overloading, and compromises on maintenance, each of which contributes to a high occurrence of accidents and mechanical failure. Service quality in terms of keeping to schedule and ensuring safety are not made priorities. Once on the road, the often unsafe trucks face

⁴⁸ European Commission, Fact-finding studies in support of the development of an EU strategy for freight transport logistics, Lot 1: Analysis of the EU logistics sector, Final Report, Brussels, January 2015

⁴⁹ See National Transport Development Policy Committee, Vol. 2, Part 1, Chapter 4. Integrated Transport: Strategy and Logistics, 2013

several problems, like potholed roads or clogged highways which reduce their speeds to about a third of that achieved by developed-world counterparts. Further, on a transnational journey, they are stopped at multiple checkpoints for inspections, payments of tolls and taxes, “tea money”, etc. It is well-acknowledged that many of these payments have no legal basis, and unjustly add to the transportation costs.

Lower operational priority and operation above capacity have implications for quality of service of freight trains and severely restrict Indian Railway’s ability to meet customer expectations. The speed of freight trains has largely remained at only 25 to 29 km per hour during the past three decades (about half of the speed of trains in the USA). Furthermore, *IR* does not operate real heavy-haul freight trains that increase the cost-efficiency of freight operations as the infrastructure is common to both, passenger and freight trains. The maximum payload carried on trains in India is 5,400 tons, compared to 20,000-37,000 tons in China, South Africa, Brazil and Australia. This is expected to change only when the Dedicated Freight Corridors (DFC) become operational, when the maximum payload will rise to 12,000 tons per train. Moreover, the parcel size of cargo is presently restricted to 2,400-3,800 tons and, therefore, leaves out many customers even in the bulk-cargo segment.

Despite growing freight transport volumes, IWT represents less than 1% of the modal share. Regardless of the efforts to improve the inland waterway sector in India, it still lacks interest from market partners, such as shippers. The mandate of IWAI is to develop and maintain the fairway and navigation infrastructure, as well as terminals to enable the commercial use of the National Waterways. Nowadays, NW-1 is used by various private cargo vessels, such as bulk cargo and general cargo vessels, tourist vessels, and IWAI vessels. States are allowed to raise levies and duties on the river, partly collected physically by state officials from the carriers directly at the state boundaries. Such kind of delays hinders timely transport flow, especially influencing the private sector and at the end the final consumer.

There is a transport subsidy for movement of raw materials and finished goods for the new industries of the North East Region, but this is applicable only for rail and road modes and not to IWT. Similarly, the transport subsidy available for movement of fertilizers is also meant for rail and road modes only.

The following table compares the investment costs related to the three modes of transport. It can be seen that the investment into waterways is by far the lowest as these are in general naturally available, while railways and roadways need considerably higher investments. With regard to the transport equipment, the acquisition costs of a barge are considerably higher than a truck, but lower than a rail wagon plus locomotive (which is necessary for the haulage and therefore has to be taken into consideration). When put into relation to the payload it shows that the required rail investments are clearly the highest for the transport of a given volume of cargo.

Table 54: Comparison of investment cost by mode in India (Rs)

Variable / Mode	IWT	Rail	Road
Cost for developing 1 km of fixed infrastructure	5,000,000	40,-60,000,000	40,-60,000,000
Transport equipment investment cost	60,-80,000,000 for a 2,000 dwt barge	150,000,000 for a locomotive 1,200,000 for a wagon	1,050,000 for a truck
Payload	1,500 tons per barge	65 tons per wagon	25 tons per truck
Investment cost for equipment required to transport 3,000 tons cargo	140,000,000	205,200,000	126,000,000

Source: HPC 2015, based on Internet research

In respect to operating costs per ton-km, IWT shows the lowest costs compared to rail and especially road. However, this cost argument has to be put into perspective, as it is generally true for single mode carriages but not for door-to-door transports including cargo transfer and pre/end haul. The total cost advantage of IWT depends much on the length of transport on waterways and the distance of the consignee to or from the transfer point. Finally, there are different types of transfer needs, closely related to the commodity as well as to port facilities and these result in different costs. In unfavorable situations the costs of transfer are double the waterway transport costs. On the other hand, many examples show that intermodal transport with inland navigation is efficient. Thus, even with additional costs in intermodal transport, as compared to direct road transport, the low costs of IWT more than compensate the additional costs of transfer and road haulage if the main leg is long enough.

Table 55: Modal comparative operating costs in India

Mode	Vehicle Operating Costs (Rs/ton-km)	Effective Taxes	Total (Rs/ton-km)
IWT	1.61	-	1.61
Rail	1.36	3.71%	1.41
Road	2.50	3.09%	2.58

Source: RITES, Preparation of Integrated National Waterways Transportation Grid, June 2013

Stakeholder interviews with regard to freight transports in the NW-1 catchment area also show that freight rates for road transports are usually clearly higher than for rail transports, depending on the origin/destination of transport. So far only limited IWT traffic takes place, but here the freight rates are even lower as the following table shows.

The IWT vehicle-operating costs derived by, and used for, the RITES study of 2013 are in the same cost range as the elaborated costs by the Consultants of this report. By comparing the figures of *Table 25 "IWT Costs for Movement of Cargo"* in *Chapter 4.2.3 "IWT"*, the RITES result does only differ slightly from the costs per ton-km of a 1,000 barge in upstream operations. Thus, the 1.06 Rs per ton-km by RITES definitely represent the upper level of costs as by increase of barge/vessel capacity and/or downstream operations the costs per ton-km decrease distinctly. It is the more conservative assumption and does not really represent an average but a maximum cost basis.

In *Chapter 4.2.1 "Railway"* costs for rail operations have been listed in *Table 21 "Railway Cost for Movement of Cargo by Cost Elements"*. The situation is quite similar as the costs mentioned

by RITES are more of the higher cost. For this report, costs have been derived based on the “Total Transport System Study” which result in 1.29 Rs. per ton-km assumed a diesel powered train is travelling on a ghat section with an incline larger than 1%. This is still below the 1.36 Rs. per ton-km without or 1.41 Rs. per ton-km including taxes. Thus, the more conservative costs have been used by RITES in 2013.

In order to compare this truck costs to the already mentioned, Rs. per ton-km in *Chapter 4.2.3 “Road”* (refer to *Table 24 “Road Costs for Movement of Cargo”*) the operating costs of trucks do contain fuel & oil consumption, labor expenses, repair and maintenance as well as depreciation and capital costs. Tolls and congestions fees are not really part of the vehicle operating costs.

Table 56: Comparison of freight costs by mode and commodity in NW-1 area (Rs)

Commodity	Road	Rail	IWT
Cement	3.40 – 4.24 /ton-km	1.61 – 3.40 /ton-km	...
Fertilizer	2.35 /ton-km	3.55 /ton-km	...
Natural aggregates	2.30 /ton-km	1.80 /ton-km	1.60 /ton-km
Petroleum products	6.72 /ton-km

Source: Consultants’ market survey, based on stakeholder interviews (point 8 of questionnaire)

From the economic point of view IWT is a low cost mode as well. The maintenance and operating costs of infrastructure are comparatively low (about 20% of that of roads). In addition, IWT is a highly fuel efficient mode of transport; it is estimated that one liter of fuel can move 24 ton-km freight by road, 85 by rail, and 105 by IWT. In summary, IWT has the lowest costs and usually pays no infrastructure charges. Prices in IWT tend to cover costs adequately, which is not the case in for road transport where market prices tend to be below cost levels, while rail transport remains highly subsidized.

6.3 Service attributes of IWT compared with road and rail

Modal shift towards IWT has not reached the desired levels yet. It is therefore important to understand first how the decision-making process of shippers and freight logistics providers works in order to know the variables that would need to be adapted from the practical side to stimulate modal shift towards IWT in promising market segments.

From the demand level, customers can have specific requests for a particular transport mode and quality of transport based on the type of goods to be transported and the dimension of the shipments. From the supply level, the modal choice is based upon two key drivers:

- Costs (i.e. door-to-door transport costs and inventory costs);
- Quality of the transport service (i.e. reliability, door-to-door transit time, flexibility, safety/security, frequency, network coverage, mass/bundling capability, availability of loading units, information exchange, organization of the supply chain, and complementary logistics services).

These two key drivers are mainly influenced by

- **Location:** Transport costs vary depending on the distance between the shipper and the recipient and the distance between those and the ports/terminals. If the shipper and/or the recipient are not located directly along a waterway, transfer of cargo onto other transport modes is needed which increases the costs. The location will also have impacts on the indicators of the quality of transport, such as the reliability (e.g. locations in structural congested areas), door-to-door transit time, the frequency of the available services, the network coverage and the bundling capabilities (e.g. based on the type and size of the economic activity in the area).
- **Transport Network Infrastructure:** This is not only related to the availability and quality of the infrastructure of waterways, railways and roads, but also to infrastructure at the terminals, ports, distribution centers and production/processing sites. These aspects affect the quality of the transport (e.g. transit time) and the level of costs (e.g. transfer costs).
- **Legal and Political Framework (in a country or corridor):** Restrictions, taxes and charges increase the level of the transport costs. Restrictions also affect the quality of transport (e.g. network coverage and accessibility).
- **External Factors:** There are other external factors such as congestion, water levels, strikes, hindrances due to accidents or infrastructure works that influence the quality of transport (e.g. reliability, transit time, network coverage and flexibility). Costs are also affected by these external factors, for example through low water charges or additional labor and fuel costs in case a truck needs to adjust its route). This results in increases in the external costs like environmental and social costs.
- **Economic Factors:** Costs are also influenced by economic factors such as the level and development of the different cost components (e.g. fuel costs, labor costs, maintenance, capital costs, insurance and other type of costs).

The quality of transport also influences the costs. For example, just-in-time deliveries are made possible by reliable transport services with a high frequency. This reduces the inventory costs. Also, the possibility of bundling cargo leads to higher frequencies of services and through higher load factors the transport costs per unit decrease.

Figure 45: Determining factors in modal shift for freight transportation

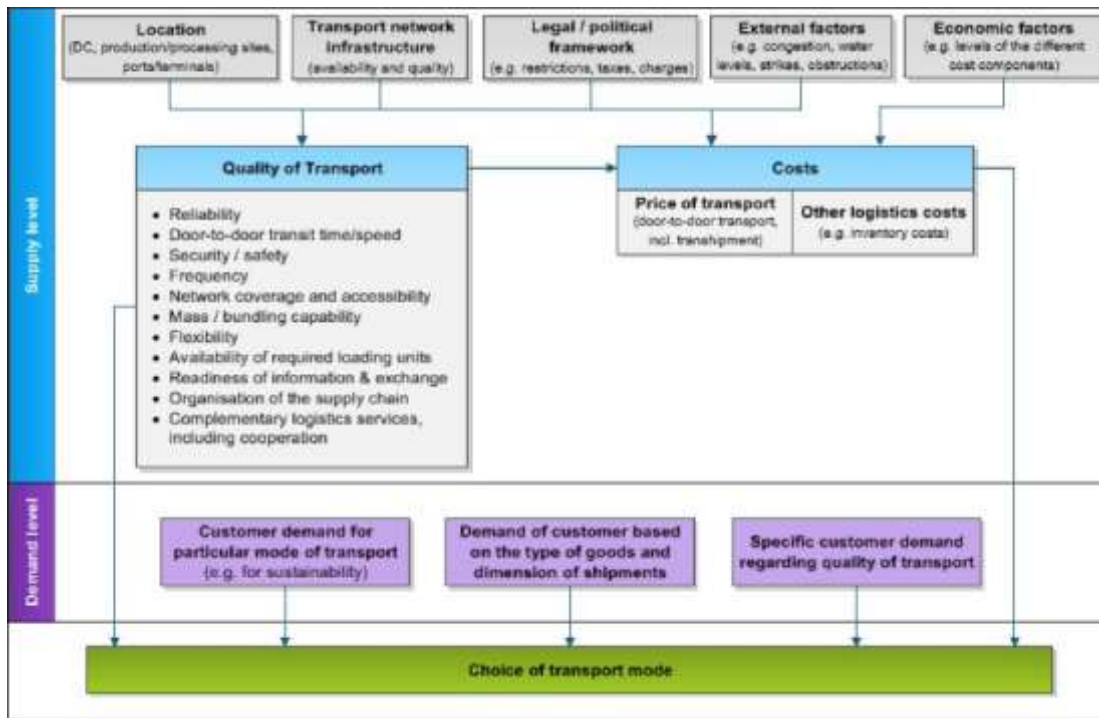

Source: EU DG Move, Platform for Implementation of NAIADES II, WP1 Market and Awareness, Page 31, Brussels 2013

Against this background, the following tables present illustrations of IWT, rail and road strengths, weaknesses, opportunities and threats (SWOT) in freight transport in general, and in India and the NW-1 in particular. The SWOT-analysis constitutes a strategic planning instrument which is used for a precise consideration of different possible strategies. The tables help comparing the three transport modes and identifying corresponding future aspects, chances and risks.

Table 57: SWOT-analysis IWT

	Strengths	Weaknesses
Internal view	<ul style="list-style-type: none"> • Large transport capacities of bulk cargo and ODC per shipment • Small risk of accidents and breakdowns • Usually no congestion on waterways • Environmentally friendly mode (least fuel consumption per ton-km, only half the CO₂ emissions of road transport) • IWT can reach both banks of a river with the same ease while other modes are obliged to bridge the rivers at high cost 	<ul style="list-style-type: none"> • Low transport speed; the usually required timely delivery depends on organization of multimodal chain • Limited area of operation, depending on sufficient depth of waterways • Time of operation limited to daytime • Hardly any door-to-door transport possible (unless sender/receiver is located at the waterway)
	Opportunities	Threats
External view	<ul style="list-style-type: none"> • Comparatively low investment costs for waterways (mostly naturally available) and low operations costs of IWT • When equipment for other modes is limited or restricted by law or size (e.g. high and heavy transports) IWT can be faster in the overall transport • More service flexibility than rail • Safe mode for hazardous cargo • Very limited land requirement • Potential for simultaneous development of a river for power creation, flood control, navigation, irrigation, industrial/urban uses, and recreation 	<ul style="list-style-type: none"> • Operation is interrupted part of the year due to weather conditions (low/high water level) • Rivers may change course leading to navigation problems

Source: HPC 2015, based on RC Agarwal Transportation, <http://www.yourarticlelibrary.com/geography/transportation/>; UNESCAP, Promotion of IWT in the Multimodal Transport World; Stakeholder Interviews

As shown in above Table 57, among the particular strengths of IWT is the ability of an environmentally friendly transport of large capacities of bulk cargo. In this, one can also see future opportunities as the corresponding equipment of other modes is likely to be either limited or restricted by law and size. Furthermore, whereas rail and road infrastructure is often subject to congestion, this is usually not the case for IWT. Among the most visible weaknesses of IWT are the low transport speed and its limited area of operation, depending on the infrastructural premises and depth of the waterways. Moreover, there are only very few cases in which IWT can offer door-to-door transport of cargo. Possible related threats for IWT include operational disruptions due to weather.

Table 58: SWOT-analysis Rail

	Strengths	Weaknesses
Internal view	<ul style="list-style-type: none"> • Fixed routes and schedules, therefore service is in general more certain, uniform and regular than other modes • High speed over long distances • Limited operating costs, esp. with regard to labor • Limited accidents and breakdowns; cargo can be protected from exposure to sun, rain, wind • Large transport capacity per shipment 	<ul style="list-style-type: none"> • Large investments in construction, maintenance and overhead; investments are immobile, i.e. in case of insufficient traffic the investments cannot be shifted and resources are wasted • Inflexibility of routes and timings, which cannot be adjusted to individual requirements • Hardly any door-to-door transport possible (unless sender/receiver is located at the rail track); usually service is tied to particular track and intermediate handling involves high cost and more time • Transport is not economical for short distances and small transport loads • No service in rural areas because of high capital requirements
External view	Opportunities	Threats
	<ul style="list-style-type: none"> • Dependable mode of transport as being least affected by adverse weather conditions and time of day 	<ul style="list-style-type: none"> • Limited number of carriers so that the lack of competition may lead to inefficiencies and higher costs • Rail in the NW-1 region is working at or beyond capacity limits

Source: HPC 2015, based on RC Agarwal Transportation, <http://www.yourarticlelibrary.com/geography/transportation/>; UNESCAP, Promotion of IWT in the Multimodal Transport World; Stakeholder Interviews

Table 58 shows that rail transport plays its strength when it comes to the transport of comparatively large shipments at a relatively high speed. As rail operation is based on fixed routes and schedules, it also offers a generally more certain and regular service than other modes of transport. In this regard, one can also see future opportunities for rail transport, as it tends to be less affected by adverse weather conditions and can offer 24/7 operations. Among the weaknesses of rail transport are the large investments necessary for construction and maintenance as well as its higher inflexibility compared to IWT and road transport. Potential threats for rail transport may result from inefficiencies and higher costs caused by a lack of intra-modal competition as well as capacity restrictions of the rail infrastructure.

Table 59: SWOT-analysis Road

	Strengths	Weaknesses
Internal view	<ul style="list-style-type: none"> • Road offers door-to-door service, which reduces transfer cost and also reduces the risk of damages of cargo • Good service in rural areas as exchange of goods between large towns and small villages is possible only by road • Flexible service as routes and timings can be adjusted and changed to individual requirements without much trouble 	<ul style="list-style-type: none"> • Higher risk of accidents and breakdowns • Limited transport volume per shipment • Unsuitable and costly for transporting bulk cargo and ODC • Restrictions for ODC/heavy load transports • Lack of organization, can be irregular and undependable • Carbon footprint
External view	Opportunities	Threats
	<ul style="list-style-type: none"> • Cost of constructing, operating and maintaining roads is lower than that of railways • Very suitable for short distances • Transport is more independent of schedules • Road is mostly required for the first and last mile transport of rail and IWT cargo 	<ul style="list-style-type: none"> • Less reliable during rainy season, when roads may be unfit and unsafe to use • Road congestion often leads to delays • Road dimensions in India often inadequate • Roads in India often in bad condition and poorly maintained (<0.1% of national income spent on road maintenance, while 3% in Japan) • Heavy tax burden on motor transport in India (tax per vehicle in India Rs 3,500 while Rs 860 in USA)

Source: HPC 2015, based on RC Agarwal Transportation, <http://www.yourarticlelibrary.com/aeography/transportation/>; UNESCAP, Promotion of IWT in the Multimodal Transport World; Stakeholder Interviews

The SWOT-analysis for road transport is shown in above Table 59. Strengths of this mode of transport include its ability to offer door-to-door services and its flexibility concerning routes and timings. As it typically covers for the first and last mile of rail transport and IWT, road transportation can possibly even benefit from future growth of rail and inland-waterway cargo. Other opportunities for road transport may result from its comparatively low infrastructure investment costs. Among the weaknesses of road transport is its limited transport volume per shipment as well as restrictions for heavy-load transports. Potential threats include poorly maintained and congested roads as well as a high tax burden on motor transport in India.

6.4 Required improvements to attract more traffic

The choice of mode is mostly determined by the shipper and his particular interests. In many cases the shipper is connected with a carrier from a certain mode. Customer-carrier relationships therefore play an important role in the decision process, particularly where they are based on long term contracts. If customers are content with the carrier's organization they do not require a check of possible transport alternatives. From this point of view, fostering the use of IWT is best done by making efforts to become involved in the decision making process, i.e. to have strong representatives of IWT in these circles.

Another important point is that shippers will not find an optimum solution for their specific transport problem without full knowledge of the conditions of available modes. As they would normally not spend much time in collecting this information themselves, they should receive offers from the representatives or operators of the modes involved. Thus, one way of promoting inland navigation is by cultivating relationships to those actors who place transport orders. That means it is important to invest in awareness and provision of information on the advantages in costs, but also quality of transport (especially reliability) of IWT for the short,

medium and long term. In order to make IWT a success the strategic and direct advantages to the shipper have to be promoted.

At the same time the existing limitations of IWT have to be addressed. The IWT sector in India is rather under-developed, mostly due to natural reasons, like limited water depth, to policy shortages, like lack of public investments and preference for other modes, and to lack of modal integration of IWT terminals with road and rail networks. The following table gives an overview of the identified limitations and reasons for not using IWT on the one hand and the proposed improvement measures on the other hand. The overleaf table is based on both, the responses of the stakeholders and potential users of NW-1 and generally available information.

Table 60: Identified IWT limitations and remedial measures for NW-1

Identified Limitations	Improvement Measures
Inadequate depth for commercial movement of cargo, and in addition severe problems of siltation so that the river bed rises, hampering movement of cargo during non-monsoon months	<ul style="list-style-type: none"> • Provision of 3m LAD along the NW-1 all year around or alternatively, design of low draft vessels • Development of river basins for the storage of flood waters in the upper catchment area, to be released during dry season while generating hydro-power; this will control floods during the monsoon and save land areas from erosion and prevent siltation at downstream end of river • Increasing stability of river banks and canals and providing a width of at least 60m*
Meandering river leads to further increasing travel distances compared to road and rail	<ul style="list-style-type: none"> • Analysis of technical feasibility of straightening the waterway to avoid bends in order to reduce the IWT route length
Inadequate air draft as several bridges with low vertical clearance hinder the passage of larger IWT vessels e.g. on canals in the states of U.P., Bihar and W.B.	<ul style="list-style-type: none"> • Raising the bridges to at least 5m above high flood level
Lack of night navigation infrastructure	<ul style="list-style-type: none"> • Provision of differential global positioning systems, light buoys, river information services etc. along the whole NW-1 to allow 24 hours navigation
Shortage of IWT vessels as new buildings are capital intensive and face financing problems; the private sector is reluctant to invest as long as no long term cargo commitments, also for return trips, are made by users	<ul style="list-style-type: none"> • Establishing a leasing company that acquires inland vessels and leases them out to operators to encourage IWT use with lower risks for operators • Setting up a dedicated IWT broker office in order to help organizing cargo movements in both directions, potentially combining shipments when feasible, to also guarantee access for shippers with less than full barge load transports
Shortage of MRO facilities	<ul style="list-style-type: none"> • Involving private sector in setting up additional IWT ship repair yard facilities on state government owned land
Insufficient terminal facilities for IWT cargo handling, leading to delays	<ul style="list-style-type: none"> • Development of modern handling facilities for the different commodities, eliminating interferences, i.e. necessary equipment for bulk, containers, ro-ro /ODC/heavy cargo as well as adequate storage space (open and covered)

Lack of multimodal connections, which hinders door-to-door transport, leading to	<ul style="list-style-type: none"> • IWT terminals need connections with other modes (at least road) for the first/last mile transport, i.e. at least all
----------------------------------------------------------------------------------	--------------------------------------------------------------------------------------------------------------------------------------------------------------------------

longer transportation times than necessary	<p>new terminals have to be planned at locations where a sufficient road connection exists or can be established, based on the analysis of origin/ destination cargo</p> <ul style="list-style-type: none"> • Setting up of industrial corridors and logistics parks to enhance trade and related services, which drive key elements of supply chain to promote IWT as gateway to industries, coastal and seaports • Creation of feeder routes to connect national waterways, especially NW-1 and NW-2 and integration of IWT and coastal shipping • Motivation of shippers to establish new businesses near NW-1 waterfront with own jetty to avoid use of other modes at least at one end of the transport chain
Missing level playing field for the three modes as rail and road receive preferential treatment by policy measures **	<ul style="list-style-type: none"> • Fiscal incentives and subsidies for freight transport should be available also for IWT, not just road and rail • Inclusion of IWT vessels in the tonnage tax regime • Equal treatment regarding transport infrastructure charges: review of waterway dues as operators do not pay for the use of roads directly
Lack of investment from public sources	<ul style="list-style-type: none"> • Review prioritization of mode support in favor of IWT or at least in a more balanced way • Increase the possibilities for private sector participation by giving incentives, e.g. by providing compensation, like tax holidays, in the beginning if cargo commitments are not sufficient in both ways to allow an economically feasible service
Missing awareness of IWT as transport alternative	<ul style="list-style-type: none"> • Setting up an IWT promotion centre integrating representatives of different stakeholders (shippers, operators, road, rail, state etc.) and developing a road-show for potential users
Low quality of IWT statistics	<ul style="list-style-type: none"> • Permanent observation of relevant economic, financial and social parameters is crucial for stakeholders to anticipate market trends; therefore, a system of systematic, complete, and periodical data collection with scheduled reviews is required • Timely publication of statistics and online availability

Notes: * See HOWE-PMC-HRW, Intervention Measures Report, page 38: "In discussion with the Transport Consultant (HPC) two navigation channel widths have been considered in the analysis. These navigation channel widths fit within the range identified in the project ToR of 60 to 120m"

** See National Transport Development Policy Committee, Vol. 3, Part 2, Chapter 4. Ports and Shipping, page 336: "The government needs to establish a level playing field between the various transport modes. While IWT is cost competitive in general with other transport modes such as rail and road, the situation is sometimes distorted by preferential treatment offered to other modes. An example is freight subsidy for transportation of fertilizer being extended to rail and road but not to IWT. This makes rail and road artificially more competitive on the cost curve and drives traffic away from IWT. Road and rail also enjoy preferential tax treatment."; see also pp. 340, 363, 369

Source: HPC 2015, based on stakeholder interviews (points 9-12 of questionnaire); NTDP, Ports and Shipping, 2013

The identified limitations and suggested improvement measures, which to a large extent are based on the stakeholder interviews, will be addressed in more detail in the "Development Strategy for IWT in India" under Part C of this project.

6.5 Business development plan

At the present stage of the project only rather general information about the plans for business development can be provided. To prepare a business plan for each commodity for NW-1, it

would have to be differentiated from which point of view these plans are developed, the shipper of cargo, the IWT vessel operator, or IWAI. IWAI, as the authority for providing navigability, is not actively involved in the decision process about shipments, but can only provide favorable framework conditions to attract IWT transports (see section above) and can facilitate the coordination between the different stakeholders.

Furthermore, a complete business plan requires considerable effort and time and has to be prepared in cooperation with the respective stakeholder. The following figure gives an overview of the strategic business development process in general. This project at present is in the process of defining the critical success factors.

Figure 46: Strategic business development



Source: <http://www.solutionstream.ca/>

The first phase of the business development process covers the outline of the descriptive information about the current business, like service features and benefits, technology descriptions and classifications, infrastructure and organization, staffing, third party service providers and suppliers, legal information, and ownership structure. In the next step the market competition is analyzed with regard to market size, segmentation and growth, customer profiles and future development potential. Based on this, a market strategy and business model is developed, defining goals and milestones, marketing and sales programs, potential alliances and value chains, operations planning, pricing approach, and risk mitigation and contingency plans. Finally, the planned financial performance is addressed, resulting in a cash flow analysis and projected use of funds.

6.5.1 Cargo services

With regard to the development of the freight transport business on NW-1 seven commodity groups have been identified that are showing further potential for IWT, namely thermal coal (imported high-calorie coal, domestic low-calorie coal), coking coal and pet coke; building materials (stone chips, cement, sand, steel coils/wires/girders); agricultural inputs (fertilizer (urea), poultry feed, agro equipment); food grains and flour (wheat, corn, rice, flour); industrial inputs (steel/iron, manganese ore, spirits, fly ash, limestone, plastics, paper); ro-ro and

containerized cargo; and over-dimensional cargo. The highest transport volumes are expected for coal, stone chips, and fertilizer (urea).

Growing domestic production and rapidly increasing import volumes of dry bulk cargoes are stretching the capacities of India's transport infrastructure, especially railways and ports. A shortage of railcars and line congestion mean that e.g. several MMT of coal pile up at the end of each year at the pit-heads of coal miners. Yet hardly a day passes without power plants suffering a critical shortage of coal. Therefore, IWT business development is essential. So far, this is hindered by several bottlenecks:

- Restriction of planning to development of trunk routes while not considering the total supply chain;
- Lack of coordinated efforts between local administration and shippers of cargo with regard to planning transport connections;
- Existing loading/unloading systems rather equipped to be used for railway and not IWT handling;
- No time schedule available for arrivals of cargo loads which requires sufficient storage space for uninterrupted production;
- Difficult warehousing conditions, stocks are exposed to pilferage and weather.
- In order to overcome these bottlenecks as well as to increase efficiency of operations and to improve logistics costs the following measures should be addressed.

In order to overcome these bottlenecks as well as to increase efficiency of operations and to improve logistics costs the following measures should be addressed:

- Coordination between the different actors of the supply chain and the infrastructure developers;
- Use of state-of-art equipment technology;
- Introduction of GPS tracking system for prediction of timing of arrivals of empties at loading points and loaded at unloading points for optimum utilization of related plants and machineries;
- Upgrade of handling terminals and improvement of distribution network;
- Cost sharing in capital investments.

In summary, and rather independent from the type of commodity, the business development of the freight transport sector on the NW-1 is largely dependent on the improvement of the technical and organizational framework conditions. Shippers have expressed their interest to use the waterway when the transport reliability can be assured.

The section overleaf discusses the costs as major determinant for feasibility of multi-modal transport of individual O/D pairs. The Consultants continue the example of the 20 important commodities, as exemplified in *Chapter 5.3*, which they selected from their Transport Model as most profitable for diversion onto the NW-1.

Table 61: Important commodities via NW-1 - multi-modal transport parameters and associated costs

Commodity Type	Entry Point NW1	Exit Point NW1	"First Mile" Distance	Distance IWT [km]	"Last Mile" Distance	Estimated Travel Time [days]	Freight Rate "First Mile" [Rs/ton]	Terminal Handling Rate (Entry) [Rs/ton]	Freight Rate IWT 2020 [Rs/ton]	Freight Rate IWT 2025 [Rs/ton]	Freight Rate IWT 2035 [Rs/ton]	Freight Rate "Last Mile" [Rs/ton]	Value of Time IWT Route [Rs/ton]	Generalised Cost IWT Route 2015 [Rs/ton]
Coal	Haldia MMT	Ramnagar	0	1,281	146	7.9	0.00	62.46	2,355.89	1,886.76	1,574.01	1,423.50	13.56	3,917.87
Fly Ash	Kolkata GRT	Other River	0	925	0	5.5	0.00	62.46	911.07	911.07	911.07	0.00	11.77	1,047.77
Iron Ore	Semaria	Haldia MMT	12	818	5	4.9	39.24	62.46	1,504.38	1,204.82	1,005.10	16.35	10.48	1,695.38
Lime Stone	Kolkata GRT	Allahabad	5	1,480	5	8.8	22.50	62.46	2,721.87	2,179.86	1,818.52	22.50	35.22	2,927.02
Sand	Raj Mahal	Kolkata GRT	8	443	10	2.7	41.40	62.46	814.72	652.49	544.33	51.75	10.67	1,043.46
Stone Chips	Sahibganj	Doriganj	5	382	25	2.3	25.88	62.46	702.54	562.64	469.38	129.38	9.32	992.03
Plastic Granules	Ramnagar	Kolkata GRT	337	1,249	5	8.1	1,845.08	54.49	2,289.33	1,838.96	1,538.71	27.38	17.41	4,288.16
Grain	Patna	Haldia MMT	21	920	0	3.2	126.00	54.49	1,686.29	1,354.55	1,133.40	0.00	20.52	1,941.78
Cement	Ramnagar	Patna	0	361	0	2.1	0.00	54.49	661.69	531.52	444.73	0.00	8.57	779.23
Fertilizer	Haldia MMT	Manihari	5	598	25	3.6	11.25	54.49	1,096.09	880.46	736.71	56.25	27.09	1,299.66
Steel	Patna	Kolkata GRT	21	815	0	2.9	126.00	141.97	1,263.07	1,015.35	850.20	0.00	11.57	1,684.58
Petroleum	Semaria	Haldia MMT	19	818	5	4.9	73.25	141.97	1,267.72	1,019.09	853.33	19.28	10.51	1,654.69
Logs & Wood	Ramnagar	Kolkata GRT	200	1,176	0	7.4	990.00	141.97	1,822.55	1,465.09	1,226.79	0.00	29.59	3,126.07
Textiles	Kolkata GRT	Ramnagar	0	1,176	152	7.3	0.00	141.97	1,822.55	1,465.09	1,226.79	1,140.00	316.08	3,562.56
Project Cargo	Patna	Kolkata GRT	21	815	0	2.9	126.00	141.97	1,263.07	1,015.35	850.20	0.00	309.86	1,982.87
Statues	Ramnagar	Kolkata GRT	31	1,176	0	7.1	227.85	141.97	1,822.55	1,465.09	1,226.79	0.00	305.19	2,639.52
Paper	Other River	Kolkata GRT	1,000	1,200	5	9.2	5,400.00	141.97	1,859.74	1,494.99	1,251.83	27.00	399.02	7,969.70
Food	Kolkata GRT	Ramnagar	0	1,176	121	7.3	0.00	96.00	4,127.87	3,386.97	2,893.04	1,270.50	46.49	5,636.86
Container	Kolkata GRT	Ramnagar	5	1,176	5	7.0	78.87	167.74	5,477.36	4,551.23	3,933.82	78.87	606.60	6,577.19
Vehicles	Allahabad	Kolkata GRT	730	1,480	5	10.3	51,103.65	36.99	10,678.50	8,720.40	7,415.00	350.03	1,104.90	63,311.07

Source: Consultants' Market Survey, August-October 2015

As the selected commodities would be transported both upstream and downstream via the NW-1, “first-mile” and “last-mile” distances would vary widely depending on the distance between origin to entry point, and destination to exit point, of the NW-1. Multi-modal transport would become most profitable with shorter distance of origin and destination from the multi-modal terminal located on the NW-1. However, only for a few cases would both origin and destination be identical with the multi-modal terminal itself, still usually one point of the voyage is located at or close to the NW-1. Freight prices for “first-mile” and “last-mile” transport would be higher than for long-distance voyages, in their Transport Model the Consultants assumed a 50% marginal increase per ton-km.

Shipping distance on the NW-1 generally amounts to at least two third of the entire voyage distance. Compared with travel time on land, multi-modal voyages of the selected commodities take an average of about 5 days, with no individual voyage lasting less than 2 days. Vehicles shipped from Delhi to Kolkata would require about 10 days, with a consequent value of time more than 3 times that of ‘mono-modal’ trucking. On average, value of time on multi-modal voyages would be about 3 times higher than pure land-based transport and reach more than 10% of the entire freight cost. Terminal-handling costs would need to be added to the pure transport costs and would be doubled where either origin or destination of the commodity is located away from the multi-modal terminal.

Shipping prices (on a per-ton basis) on the NW-1 would average about Rs 1,000 per voyage, as the operator needs to calculate his costs for the entire round trip. The Consultants expect these freight prices to decline over a certain period of years (in their Transport Model between the years 2020 and 2035), as the market and logistical information network develops thus providing the operator with opportunities of full-load return voyages.

In a sum, aggregated (generalized) costs (on a per-ton basis) for a voyage remain below Rs 5,000, again with the significant exception of vehicles and some special commodities such as general cargo as break-bulk or containerized.

6.5.2 Passenger services

The economic benefits of the river cruise shipping industry to the State are felt beyond the tourism sector, with operational expenses accounting for the majority of the direct expenditure, followed by corporate, passenger, and crew expenses. Operational expenses include expenditure such as fees for navigation and berthing, supplies such as fuel, food and beverage provision, and potable water, services such as wastewater and garbage removal, and passenger related services such as security, baggage handling and passenger levies. Corporate expenses comprise other expenditure by cruise operators, like corporate head office activity, advertising, sales activities, commissions, and general administration costs, depending on the office location.

Passenger expenses consist of expenditure by the passengers in their ports of call, including shore excursions, meals, transportation, admission to attractions, shopping, and accommodation. Crew expenses include expenditure of crew members in their ports of call, including meals, transportation, telecommunications, shopping, accommodation, and other recreational spending. That means that local commercial opportunities may evolve e.g. for

suitable hotel accommodation developments, for excursion guiding services, and high volume transport providers.

In order to develop the river cruise tourism business on NW-1 and to maximize the economic benefit of cruise shipping to India, the following goals need to be addressed:

- Provide sustainable infrastructure, efficient and safe operations, and ship services;
- Develop relationships with cruise lines in order to deliver goods and services that meet the needs of the river cruise market;
- Marketing of NW-1 as desirable cruise destination and work with neighboring areas to promote the whole region;
- Product development of onshore experiences (excursions);
- Simplify administrative, immigration, and customs procedures;
- Carry out regular passenger surveys to gather feedback in order to address potential concerns.

Cruise lines' deployment decisions are motivated by economic objectives; they will position their assets where they can achieve the greatest profit. Factors such as the potential local or regional source market, aviation access, port infrastructure and support services, tourism infrastructure, climate and the overall appeal of a region are considered carefully when deciding where to deploy vessels.

Shore excursions are a major revenue centre for every cruise line. Cruise lines rely heavily on their locally based agents to provide solid advice on the experiences that best represent a particular port/region, and that have the best potential to generate maximum profit. To make shore excursions more attractive, cruise lines (through their local agents) will be more likely to offer tours or experiences that

- can only be experienced in a particular area of call,
- have good marketing appeal,
- involve some level of interaction with local people, and
- leave enough time on the schedule to explore the area independently.

In summary, for developing the cruise tourism business a close contact between the different market players is essential. Besides provision of the necessary infrastructure and services, the region should develop a unique selling proposition that is communicated to the market.

6.5.3 Ferry services

Ferry services provide an alternative to land transport connections and are on the other hand sometimes the only way to cross a river in the absence of bridges in the vicinity. Ferry customers, who rely on ferry services to go to and from work or education, want fast, reliable services. They rely on good interchange opportunities with other modes such as bus and train. These customers generally travel in the morning and afternoon peaks. Tourist and leisure customers want comfortable, reliable services in the off peak periods and on weekends to key destinations.

Interviews with international ferry operators within the framework of a different project have resulted in the following success factors for developing a ferry service business:

- Travel time (and hence travel speed) and competitive fare

- Frequency and reliability of services
- Integration with other transport modes
- Quality of infrastructure
- Market development (i.e. associated land uses to attract support)
- Convenience and accessibility of service
- Passenger comfort and pleasantness of journey
- No alternative mode available, e.g. because bridges are not existing

The continuous population growth and an increase in vehicle numbers have exceeded the carrying capacity of the transport system along the NW-1 corridor. However, the location of the river Ganges provides an opportunity for urban and rural passengers to use this waterway. For example, in the transport system of Kolkata, where buses, automobiles, and metro rail dominate the urban traffic, an integrated inland water transport system should be developed with a suitable coordination with bus stops as well as sub-urban and metro railway stations. In 2011, ferry services accounted for only 1.7% of the total passenger movements, while buses carried 55.7% of the passengers travelling in Kolkata on an average weekday.

The basic problems of the ferry services can be identified as follows:

- Navigational:
 1. Siltation on lower part of Bengal delta creates problems for the movement of ferries
 2. Shallow water during dry season results in difficulties for ferry movements
 3. Some areas are prone to bank erosion leading to the siltation
 4. Water pollution interfering with functioning of motors of vessels
- Infrastructural:
 1. Non-availability of terminals, repair centers, river traffic management system
 2. Inadequate navigational aids, insufficient ferry landing stages, unsatisfactory ticketing system
 3. Lack of integration between public and private sectors
- Connectivity:
 1. Delays due to long transfer times between other modes and the ferry because of the distance between main roads and ferry landing stages
 2. Busy waterway hinders direct connection between different ferry landing stages when priority has to be given to other transports

In order to develop the ferry business on NW-1, the following measures for extension and strengthening should be addressed:

- Regular dredging of the river and provision of navigational aids;
- Ban of waste disposal into the river;
- Construction of permanent ferry jetties replacing the existing temporary landing stages;
- Introduction of new and frequent ferry crossing points with permanent jetties;
- Deployment of more motorized vessels and increasing the frequency of departures;
- Extension of ferry service times in the morning and in the evening;

- Linking the ferry connections with bus routes.

To reduce pressure on road and rail passenger transport services, appropriate planning, coordination and management of the ferry business is necessary. Strategic investments in water transport can positively impact overall costs and competitiveness of the other transport modes and may lead to new job opportunities.

Considering the above-described advantages and bottlenecks, the Consultants identified the following potential locations for ferry services crossing the Ganges River by:

1. Analyzing maps of market surveyors for cargo traffic crossing NW-1;
2. Urbanization patterns for larger settlements in proximity to NW-1; and
3. Transport infrastructure network for larger connecting roads close to NW-1.

These following potential sites still need to be checked by the engineering consultants Howe (India) for their physical condition (ro-ro connections proposed by IWAI are emphasized in bold letters).

6.5.3.1 Uttar Pradesh

1. Medhwa – Chochakpur
2. Madanpura – Pallia
3. Dullahpur – Ballia
4. **Buxar – Doriganj – Ballia**

6.5.3.2 Bihar

5. Maner – Doriganj
6. **Fatuha – Patna – Digha Ghat – Sherpur**
7. Barh – Baghrah
8. **Semaria – Mokama**
9. Sultanganj – Parbatta
10. **Kahalgaon – Teen Danga – Munger**

6.5.3.3 Jharkhand

11. **Rajmahal – Sahibganj – Manihari**
12. Rajmahal – Manikchak (container traffic Haldia – Biratnagar / Nepal)

6.5.3.4 West Bengal

13. Manigram – Lalgola
14. Hazarduari
15. Depara – Debagram
16. **Sagar – Lot 8 – Haldia MMT – Kolkata GRT – Tribeni**

Figure 47: Potential ro-ro ferry connections along NW-1

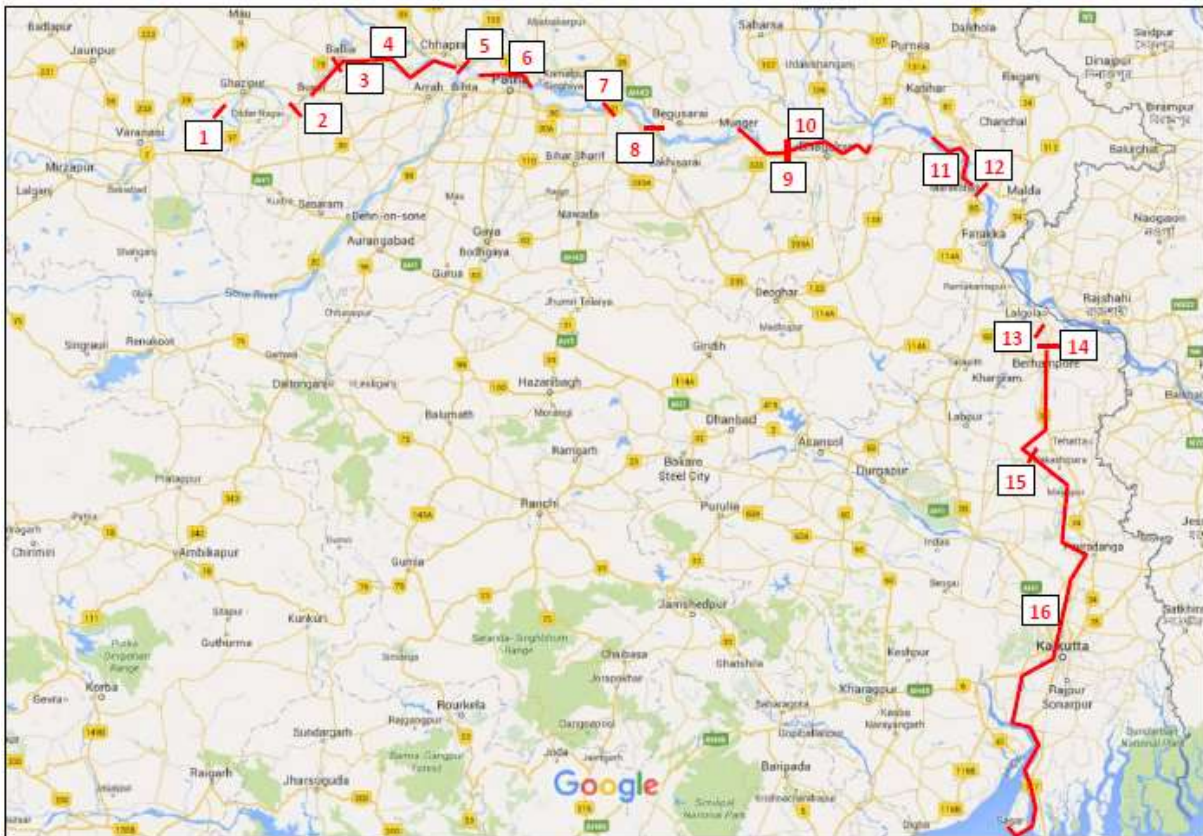

Source: PMU / IWAI; Consultants' analysis based on market survey July-October 2015

Another important ferry link could be established at Sagar Island, to connect Kochuberia Ghat (see below Figure 49) in the northeast of the island with LCD Ghat on Lot 8 in just 3 km distance across a side branch of the Hooghly River.

Figure 48: Ferry at Kochuberia Ghat



Source: Google Earth

7 IWT Competitiveness

7.1 NW-1 potential and constraints

The following potential and constraints of IWT constitute major determinants of the worstcase and best-case traffic projections as presented in Chapter 8 and 9.

7.1.1 General potential

During the Consultants' market survey, general opportunities have been described as follows:

- Huge trade potential exists in the eastern and north eastern region as a result of increasing investment from private companies as well as from the exposure to South Asian and neighboring economies like Bangladesh and Myanmar.
- Domestic shipping provides significant fuel and cost savings over road and rail transport and, thus, offers several opportunities to meet the demand for bulk shipping to nearby areas and along the coast, which is highly relevant for India.
- Sufficient water depth would provide a tremendous boost on the NW-1 since already some cargo is being shipped on this route. For instance, one company is getting many enquiries for liquid and sand movement, and with availability of 3 meters water depth and stable channels it could fulfil these requests.
- Opportunities will open up only when the service is available at Haldia MMT. For some companies a MMT at Haldia would provide immense advantages for their commodities on the NW-1, as origins and destinations of their cargoes lay exactly on the NW-1 route. A Haldia MMT will definitely give a boost to IWT which was largely untapped and underutilized despite its high growth potential. A ro-ro facility for heavy lift and ODC cargo should be provided at the proposed Haldia MMT which will surely offer a lot of opportunities to meet the requirement for shipping such commodities along the NW-1 and NW-2. For instance, a company is interested in using the Indo–Bangladesh Protocol Route for its commodity supply in larger volume from Kolkata to the NW-2 if this can be shipped cost-effectively. Another company might supply commodities to northern destinations if the IWT service was cost effective.

Following quotations give a valid impression of the prevailing sentiments of potential NW-1 users:

- We have a requirement of 10,000 tons per month of cement supply in 24 districts, which we would like to transport on the NW-1 from Haldia MMT (*source: ACC Ltd., Damodar Cement Works*).
- We have a requirement of 50,000 tons of aggregates per month to be supplied to Chittagong/ Bangladesh, which we would like to ship by waterways from Pakur / Sahibganj to Bangladesh (*source: Chandak & Associates*).
- We are not interested in owning barges but we can provide or build some infrastructure on the bank of the NW-1 near Pakur and Sahibganj at our own cost if IWAI provides land.

- Our manufacturing plant is very near to the proposed Haldia MMT. We are very much interested in using the NW-1 for our commodity, especially for transporting material from U.P. to Haldia and also for in-bound supply if this can be done cost-effectively. Presently we are not producing much of our commodity, but the scale will definitely grow in the near future.
- Our manufacturing unit is 140 km from the proposed Haldia MMT. We are interested in using the NW-1 for shipping our commodity from Kolkata to the Bihar region and also for in-bound supply if cost effective. Presently production of our commodity is not much, but we intend to play a bigger role in near future.
- Ready to invest for both options as our expertise in port infrastructure and equipment operations would give us an upper edge to participate in such PPP proposals(*source: J M Baxi & Co.*).
- Setting up of industrial corridors and logistics parks with enhance trade and related services which will drive key elements of supply chain to promote IWT as gateway to industries, coastal and other major ports(*source: J M Baxi & Co.*).
- Require massive change of the pattern to develop the trade (*source: Everett India Pvt Ltd*).
- Presently no incentive scheme is known however infusing capital investment would definitely support the IWT mode of transport. However unless there is a clear roadmap for providing stable channels this may not have the desired effect. We have been investing in inland waterway Barges and Tugs for the past 40 years to meet our client requirements (*source: Eastern Navigation Pvt. Ltd*).
- We can invest in inland barges and RSV tankers (*source: Vivada Corporation Pvt Ltd*).

7.1.2 Cargo sector

7.1.2.1 Haldia-Farakka sector

Following table discusses potential and constraints of commodities which will most likely pass through the Haldia MMT or Kolkata GRT.

Table 62: Potential and constraints of commodities transported on NW-1

Commodity	Description of Potential	Description of Constraints
Coal	Commodity with potential presently transported through waterways from Sagar to Farakka and also large quantity of Coal transported from Pakur region for Kolaghat Power Station which may be handled at the MMT.	No availability of IWT service at NW-1
Cement	Commodity is mainly for local supply but if demand is there for NW-1 and NW-2, Haldia MMT will be the right place for both NW-1 and NW-2 destination	Presently supplying only at Kolkata by roads. Nearest MMT is far away from the Plant
ODC	Commodity with huge potential as per requirement by the upcoming Cement / Power Industries along the NW-1 and in NE region of India	Proper Ro-Ro facilities / service for handling ODC is not there along NW-1
Fertilizer	Commodity with huge potential especially wheat from North India to SE-NE India and rice from West Bengal to North/NE India. Maize from Patna to Kolkata and further exported overseas	No availability of IWT service at NW-1
Crude vegetable oil	25,000 tons of crude edible oil monthly from Haldia to Varanasi Nepal-bounded cargo could be viably handled if containerized and handled at Patna Haldia to Northeast India: 300–400 tons daily for mill production/operations	No availability of IWT service at NW-1
Stone chips	Commodity with potential and in demand at Kolkata and Bangladesh may be handled at Haldia MMT or Kolkata GRT	No availability of IWT service at NW-1
Automobiles	Commodity with potential and in demand at Kolkata Large no. of units transported from North to Kolkata by road Commodity may be diverted from plant to Allahabad or Varanasi and thereafter by waterways to Kolkata	No availability of IWT service at NW-1
Containers	Large no. of containers transported from Kolkata to Nepal (Biratnagar) by road Commodities may be transported by waterways from Kolkata to Patna and thereafter by road to Nepal	Availability of service at NW-1 although it may not be feasible as the Patna Terminal being on south bank of Ganges River, boxes need to be transported to north bank for Nepal

Note: This table shows a pure market response from market interactors based on real day-to-day experience, collected by the Consultants' interviewers

Source: Consultants' Market Survey, August-October 2015

7.1.2.2 Farakka-Munger sector

The following potential and constraints of IWT are the determinants of the worst-case and best-case scenarios in the traffic projection for Sahibganj MMT.

Table 63: Potential and constraints of commodities transported on NW-1

Commodity	Area - Production/Consumption	Loading Point/Station	Description of Potential			Destinations	Nearest IWT Terminal for Unloading	Description of Constraints	
			Distance of Source Point to Sahibganj IWT (in Kms)	Current Mode	Potential (in tons per day)				
Stone Chips and aggregates	Sakrigali	Sakrigali	3	Rail	2,586	North of Bihar-Average distance travelled is 350 Km	Patna MMT	High scope for transfer onto IWT	
	Sahibganj	Sahibganj	10	Rail	1,138				
	Mirzachowk	Mirzachowk	32	Rail	1,197				
		Sakrigali	Sakrigali	3	Road	25,600	North of Bihar-Average distance travelled is 350 Km	NA	Significant share of the amount is unofficially mined and hence doesn't represent the actual demand. Curtailment to be done while calculating the actual potential
		Sahibganj	Sahibganj	10					
		Mirzachowk	Mirzachowk	32					
		Sahibganj	Sahibganj	10	By Naukas	12,627	Till Manihari and then to destinations on North of Bihar.	NA	Significant share of the amount is unofficially mined and hence doesn't represent the actual demand. Curtailment to be done while calculating the actual potential
		Sakrigali	Sakrigali	3					
		Bakudi	Bakudi	50	Rail	3,555	North of Bihar-Average distance travelled is 350 Km	Patna MMT	Access distances are higher and hence the cost benefits might be much
		Barharwa	Barharwa	57	Rail	2,792			
	Pakur	Pakur	96	Rail	13,762				
Coal	Lalmatiya	Pirpanti	72	Rail	1,764	Several Thermal Power Station	Patna MMT	Access distance is higher and most of the thermal power plants have railway sidings which enable direct unloading at the thermal power station which is unlikely in case of waterways. Cost advantages need to be worked out. In case of imported coal at Haldia, cost advantages work in favor of IWT.	
	Amrapara	Pakur	112	Rail	20,044	Several Thermal Power Station			
	Andal	Respective railway sidings and unloaded at Kahalgaon Thermal Power station railway siding.	Kahalgaon Thermal Power Station is 61 Kms away from Sahibganj MMT.	Rail	16,336	Origins include Andal in west Bengal, Lalmatiya in Jharkhand and imported coal dumped at Haldia	Sahibganj MMT	Kahalgaon Thermal Power Station has a railway siding and hence unloading happens within the power station. Kahalgaon is 60 km away from Sahibganj IWT and hence higher costs in transporting from MMT till Kahalgaon. Holds advantages at loading points as they are along the Ganges River e.g.: Haldia. Costs need to be worked out to ascertain the advantage of IWT over the existing mode of travel.	
	Lalmatiya			Rail					
Cement	Baghalpur	Unloading at Baghalpur Railway Station.	92	Rail	662	Origins include several cement production plants	Sahibganj MMT	Most of the cement plants have railway siding and hence the access distance to IWT becomes an additional cost over current mode of travel. Cost benefits need to be worked out	
	Sahibganj	Unloading at Sahibganj Railway Station.	10	Rail	87				
Rice	Baghalpur	Unloading at Baghalpur Railway Station.	92	Rail	563	Origins include the regions on North of India like Punjab, Haryana etc	Patna MMT	Not a potential as the origins are way further North of India	
	Sahibganj	Unloading at Sahibganj Railway Station.	10	Rail	130				
Fertilizer	Baghalpur	Unloading at Baghalpur Railway Station.	92	Rail	114	Baghalpur	Sahibganj MMT	Could be a potential as origins include areas in West Bengal and Andhra Pradesh	
Flyash	Kahalgaon Thermal Power Station.	Kahalgaon Thermal Power Station.	61	Rail	1,733	Destinations include North east of India and Bangladesh	Sahibganj MMT	Could be a potential as most of the distance falls on waterways	

Note: This table shows a pure market response from market interactors based on real day-to-day experience, collected by the Consultants' interviewers

Source: Consultants' Market Survey, August-October 2015

7.1.2.3 Muner-Ballia sector

This market-survey region between Munger to the east and Ballia to the west holds a great potential in that the NW-1 follows a rather straight west-east course. When dredged to sufficient depth and maintained in this condition, this section of the waterway is well located to serve the multi-modal cargo traffic between the industrial region of Varanasi to Allahabad (and beyond to Delhi) and the agricultural region of Bihar (and beyond into Northeast India).

Its future multi-modal terminals along the NW-1 will be well positioned to serve as lifeline nodes for cargo traffic into Nepal, both from the seaports of Haldia and Kolkata as well as from the industrial areas in western W.B., such as Durgapur.

7.1.2.4 Ballia-Allahabad sector

The following potential and constraints of IWT are the determinants of the worst-case and best-case scenarios in the traffic projection for Ramnagar MMT.

Table 64: Potential and constraints of commodities transported on NW-1

Commodity	Potential	Constraints
All commodities	<ul style="list-style-type: none"> • If overloading of trucks can be controlled, IWT will be more feasible; • If two-way cargo is available, then IWT will become feasible; • The provision of basic data (lock dimension, rates, fees, operating hours etc.) on the IWAI website is highly appreciated; • The cargo as well as the region where the vessel is supposed to go is influencing the vessel design. 	<ul style="list-style-type: none"> • Specification of vessels types which will be used on the NW-1 is required; • 24-hour operation on the river is a must; • There are huge doubts about continuous provision of sufficient draft; • Buoys are needed for water transport; • Policy support from government for use of IW is needed, only cost advantage is not enough; • KoPT controls IW from Sagar to Nabadweep, not IWAI; jurisdictional issues cause problems;
Coal	<ul style="list-style-type: none"> • Upcoming power plant projects are generating construction cargo which could be transported by IWT; • Some plants are not 100% utilized due to insufficient supply of raw material; supply cannot be covered by rail as its capacity is at nearly 100%; additional racks/rail cars are available but no more track capacity; rail infrastructure is generating a bottleneck; • Full trip from Kolkata to Allahabad and back within 12 days is possible and would be a competitive product; • Coal can be taken in barges to Allahabad; • Vessel are under development having a capacity of 1,500 t and a draft of 1.6m as well as vessel with a capacity of 2.7 t and a draft of 2m; • Three barges are chartered for coal transport having a capacity of 2,000 t each; • A vessel with a capacity of 2,800 t and a draft of 3m has been designed (but not 	<ul style="list-style-type: none"> • River changes course rapidly; • For liquid bulk pipelines are available; • Vessels are needed on a regular basis, as per schedule, to build credibility of IWT; • Marketing and road show is important to create an image; • Promotion of water transport is needed to create an image; • Customs department inspection is required for imports, therefore a warehouse is needed; • Interaction with state governments and Customs is required; • Tide and current are issues; • Goods have to be delivered reliable / on time; • Farakka lock has to work reliably 24 hours every day; • A second lock seems necessary; • Sufficient draft is the most important criterion to generate a reliable IWT infrastructure;

	<p>built yet); with length about 80m which is probably quite long, especially for some turns in Farakka area.</p>	<ul style="list-style-type: none"> Establishment of a river police will be necessary, if cargo/traffic will increase; currently there is no regulation;
Cement	<ul style="list-style-type: none"> Upcoming cement plants are generating construction cargo which could be transported via IW. 	<ul style="list-style-type: none"> How to handle pontoon bridges? The opening and closing of these bridge is not regulated and therefore not predictable; local authorities are responsible for opening and closing;
ODC	<ul style="list-style-type: none"> Upcoming power plant projects (and cement plants) are generating project cargo which could be transported via IW; Forwarding companies focusing on ODC (heavy lift and projects) already exist; <i>Prism Logistics</i> want navigable channel until Allahabad not only until Varanasi; <i>Eastern Navigation</i> has an own shipyard to customize their vessels if needed; the company builds two vessels/facilities annually; currently a fleet of 65 vessels/facilities. 	<ul style="list-style-type: none"> IWT with a depth below 3m is not viable on a regular basis; the operating costs for vessels with a 2.5m draft are higher (unit costs) as for 3m draft vessels.
Fertilizer	<ul style="list-style-type: none"> <i>IFFCO</i> is thinking about using the RSV 4 (which are allowed to go up to 12nm sea); Floating pontoons seem to be the most flexible way of cargo handling facility: floating barges used as storage facilities for fertilizer, as the consumers can only handle “handy” volume, would also reduce storage costs. 	<ul style="list-style-type: none"> A multi-modal terminal has to provide a covered warehouse; currently 10% of total fertilizer production gets lost annually due to weather effects (rain).
Crude vegetable oil	<ul style="list-style-type: none"> There is Nepal-bound cargo, if containerized and handled at Varanasi; The transport of crude edible oil is very likely to be shifted to IWT, if opportunities are there; Probably vessels can stop-over at Patna, discharge partly to proceed with lower draft to Varanasi; but currently there is no refinery at Patna; Currently the supply of 6-7 oil refineries is all done by road; 8,000 – 10,000 tons daily of canned oil products; 1,500 tons by max. 3m draft should be targeted; Pump and liquid storage facilities (3,000m³ - 4,000m³ per tank) have to be provided at the inland ports of discharge (e.g. Varanasi). 	<ul style="list-style-type: none"> Especially palm oil has to be heated during transport.
Containers	<ul style="list-style-type: none"> Pilferage on road and rail is a big issue; At Patna liquid bulk and general cargo is needed; Filling containers in Varanasi with sarees, carpets, cars (<i>Maruti Suzuki</i>) would reduce empty back-hauls of import containers. 	<ul style="list-style-type: none"> Door to door service is needed by clients (<i>Bothra</i> tried for containers earlier, but it did not work).

Note: This table shows a pure market response from market interactors based on real day-to-day experience, collected by the Consultants’ interviewers

Source: Consultants’ Market Survey, August-October 2015

7.1.3 Passenger sector

High potential exists for cruises, both for religious and tourism purposes, in the Ballia-Allahabad sector around the city of Varanasi. The Consultants had discussions with the Banaras House Group; the following is a quote from the company's chairman⁵⁰:

- For the initial phase as requested earlier to IWAI, we chose the route Gajipur to Ramnagar of approximately 100 km, which is presently - according to our knowledge - being covered for passengers and cargo by traditional boats of various capacities;
- There are approximately 500 traditional boats which are plying over the route and catering to both domestic and foreign visitors;
- We had already requested IWAI as well as your partners CNTechnologies, Mr. Anant Verma, for collecting the necessary data and detailed information;
- IWAI is very hopeful that the Ganges River all along from Haldia to Allahabad could be useful in the long run;
- We also believe that due to the influx of over one million visitors to Varanasi, being one of the oldest living cities on earth and having great religious appeal, ever-growing traffic would be eager to adopt modern transport facilities on the route in spite of various constraints of water depth and environment;
- Looking at the above factors, our activities as envisaged include putting in operation Hovercraft Services with a capacity of approximately 35-40 passengers to run point-to-point depending on the traffic requirement, which only a qualified consultant like CNTechnologies or the Consultants could provide;
- Our collaborators in Australia, manufacturers of Hovercraft, are eager to co-operate provided the project is commercially viable without any restriction or hindrance;
- As already informed earlier, various issues are still pending for consideration with IWAI and I am sure additional information could be available from their various offices in the region;
- Unfortunately, we are not able to provide sufficient information as required due to non-availability of this service as yet.

⁵⁰ Mr. Binay Kumar, Chairman (cell 09891287666, mail headoffice@banaras.com) Banaras House Group, New Delhi

8 Cost Competitiveness

8.1 Cost competitiveness comparison rail against IWT

Specifically applying to the three detailed observed sectors/terminal areas - Haldia MMT, Kolkata GRT and Sahibganj MMT – and based on the findings of the market surveyors, the Consultants established weighed rates per ton-km for cargo transports on land (road, railways) in the following table. Due to the spare barge traffic on the NW-1 and consequent low availability of freight rates, the Consultants proposed competitive freight rates for the various cargo types on the NW-1.

Table 65: Comparison of freight tariff levels of road, rail and IWT along NW-1 (Rs/ton-km)

Cargo Type	Haldia MMT		Kolkata GRT		Sahibganj MMT		IWT NW-1
	Road	Railway	Road	Railway	Road	Railway	
Dry bulk	1.95	2.14	2.00	2.26	3.62	2.41	1.30
Liquid bulk	<i>n.a.</i>	<i>n.a.</i>	4.00	<i>n.a.</i>	<i>n.a.</i>	<i>n.a.</i>	6.70
Bagged	2.39	<i>n.a.</i>	2.28	2.23	2.61	1.62	1.10
General	<i>n.a.</i>	<i>n.a.</i>	<i>n.a.</i>	<i>n.a.</i>	3.50	<i>n.a.</i>	<i>n.a.</i>
Neo-bulk	<i>n.a.</i>	2.50	3.11	2.17	<i>n.a.</i>	<i>n.a.</i>	1.40
Ro-ro	<i>n.a.</i>	<i>n.a.</i>	<i>n.a.</i>	2.47	<i>n.a.</i>	<i>n.a.</i>	7.00
Container	7.95	<i>n.a.</i>	6.33	<i>n.a.</i>	<i>n.a.</i>	<i>n.a.</i>	4.50

Note: Railway fare includes 5% additional development charge over the total freight rate, 15% busy season surcharge (not applicable in July, August and September months), and 4.2% service tax

Source: Planning Commission; Manual on Economic Evaluation of Highway Projects in India, Indian Road Congress; IWT freight tariffs according to market survey interviewees; calculations by Consultants

As proposed, the IWT-freight rates (in particularly, Rs 1.3/ton-km for dry bulk, Rs 1.1/ton-km for bagged, Rs 1.4/ton-km for neo-bulk cargo) are below the established land freight rates at such a level so that a shift of cargo onto the NW-1 becomes quite likely, while at the same time providing sufficient income to the shipper. This kind of iterative process has to be continued steadily in order to provide the ideal rate for both forwarders and ship owners.

Actually, transportation costs need to be worked out for the origin and destination pairs presented for the commodities being carried to ascertain the amount of traffic that can probably find a way to IWT as and when opened. Cost comparison between the three modes available with respect to the origin and destination pairs need to be worked out to estimate the probable amount of traffic that can be transferred on to the waterways.

The following tables show exemplary calculations for all three transport modes. The examples focus on transport of the bulk commodities coal and cement. Bulk is transported from Kolkata to Barh and cement is transported on the way back from Barh to Kolkata.

Figure 49: Map of transport cases Kolkata-Barh

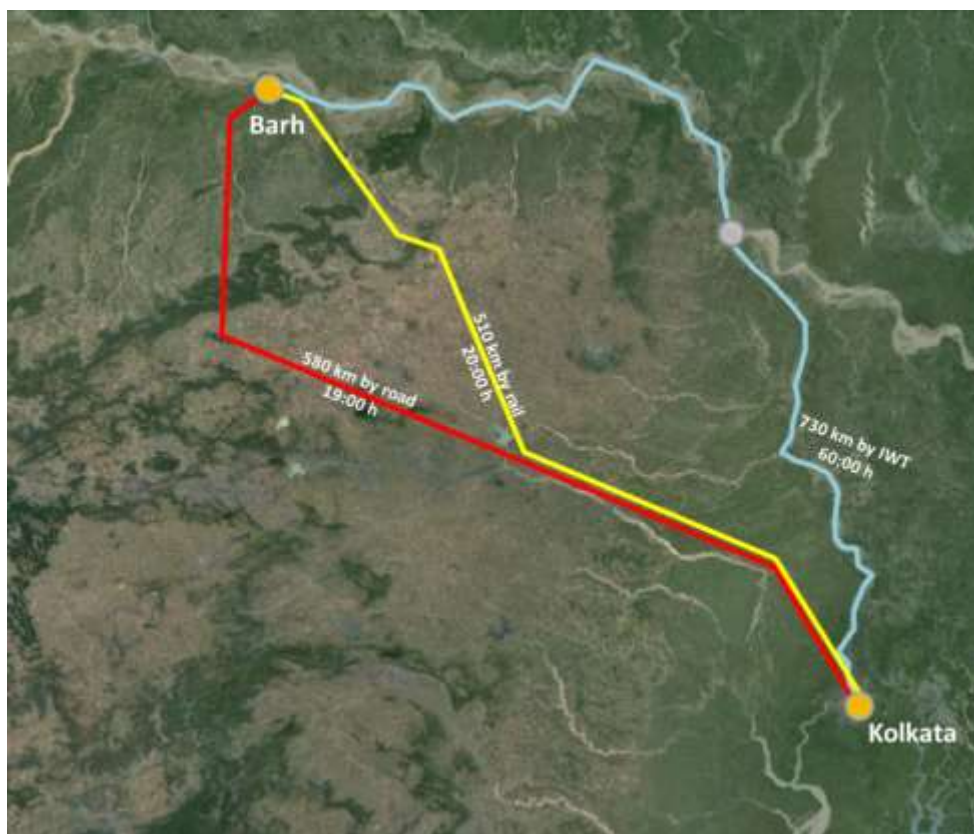

Source: Google Earth; Consultant's illustration

For each transport mode two transport “vehicle” alternatives have been considered. The freight rates for road and rail transport are the mean value of the Kolkata-rate and the Sahibganj-rate.

Table 66: Costs and earnings per trip for road transport of coal/cement between Kolkata and Barh

Road	Dry Bulk / Coal				Dry Bulk / Cement				Whole Trip				Average speed				
	Truck utilization 100%	Section: Kolkata to Barh			Costs total	Earnings 2.8 Rs. per ntkm	Truck utilization 100%	Section: Barh to Kolkata			Costs total	Earnings 2.8 Rs. per ntkm	Costs	Earnings	Margin	Average speed 30 km/h	
	Transport volume [t]	Cost / Rs. per ntkm	Cost / Rs. per trip	Rs. per passage	Rs. per trip	Rs. per trip	Transport volume [t]	Cost / Rs. per ntkm	Cost / Rs. per trip	Rs. per passage	Rs. per tour	Rs. per tour	Rs. per tour	Rs. per tour	Rs. per tour	travel time [h]	in days
16 t Truck	16	3.03	28,094	incl.	28,094	26,077	16	3.03	28,094	incl.	28,094	26,077	56,188	52,154	-4,034	39	1.6
24 t Truck*	24	2.02	28,094	incl.	28,094	39,115	24	2.02	28,094	incl.	28,094	39,115	56,188	78,230	22,043	39	1.6

* overloaded by 50%

Source: Planning Commission; Manual on Economic Evaluation of Highway Projects in India, Indian Road Congress; findings by market surveyors; calculations by Consultants

The load capacity of one truck has been assumed as 16 tons as well as 24 tons. Thus, up to 24 tons can be transported per one trip assuming a truck utilization of 100%. A fully loaded truck is quite likely. The distance by road from Kolkata to Barh is about 580 km. The road toll has already been included in the costs per ton-km. The cost per one trip (one way to Barh) has been calculated by transport volume x distance km x Rs per ton-km. The existence of rail fees has not been identified during the elaboration of this report. The average speed of a truck has been assumed being 30 km/h which leads to transit time for a round trip of 39 hours net (without breaks and waiting time). The table shows that the operations with only 16 tons of load capacity do not lead to an economic result but generating a loss about Rs 4,000.

Table 67: Costs and earnings per trip for rail transport of coal/cement between Kolkata and Barh

Rail	Dry Bulk / Coal						Dry Bulk / Cement						Whole Trip						
	Train utilization		Section: Kolkata to Barh			Costs total	Earnings 2.3 Rs. per ntkm	Train utilization		Section: Barh to Kolkata			Costs total	Earnings 2.3 Rs. per ntkm	Costs	Earnings	Margin	Average speed	
	90%	510 km	Cost / Rs. per ntkm	Cost / Rs. per trip	Rail fee			90%	510 km	Rail fee	Cost / Rs. per ntkm	Cost / Rs. per trip						Rs. per passage	Rs. per tour
	Transport volume [t]*																		
1,800 t Train	1,620	0.94	780,520	n.a.	780,520	1,929,177	1,620	0.94	780,520	n.a.	780,520	1,929,177	1,561,040	3,858,354	2,297,314	41	1.7		
2,200 t Train	1,980	0.94	953,969	n.a.	953,969	2,357,883	1,980	0.94	953,969	n.a.	953,969	2,357,883	1,907,938	4,715,766	2,807,828	41	1.7		

* average load per IR train 1,823 t (2012/13)

Source: IR "Adjustments in Base Freight Rate effective form 01.04.2015"; findings market surveyors; calculations by Consultants

According to the statistical yearbook of IR, the average load per train has been around 1,823 tons in the fiscal year 2012/13. In order to get two possibilities, train capacity slightly above and slightly below the average have been chosen. Due to sometimes unplanned changes in provision of rolling stock, mainly wagons/rail cars, the train utilization has been assumed being 90%. The distance by rail between Kolkata and Barh is about 510 km. The costs per km have been taken for electrified, double line ghat-landscape. The average speed of a train according to the statistical yearbook 2011/13 of IR is around 25 km/h. This has been taken for further calculation leading to a net travel time for a whole round trip of about 41 hours (without breaks, waiting time etc.). Rail net travel time is almost comparable to truck net travel time. The calculation shows the economies of scales as the train with the larger load capacity generates a higher margin.

Table 68: Costs and earnings per trip for IWT transport of coal/cement between Kolkata and Barh

IWT	Dry Bulk / Coal								Dry Bulk / Cement								Whole Trip								
	Upstream		Section: Kolkata to Farakka			Section: Farakka to Barh			Costs total	Earnings 1.3 Rs. per ntkm	Downstream		Section: Barh to Farakka			Section: Farakka - Kolkata			Costs total	Earnings 1.3 Rs. per ntkm	Costs	Earnings	Margin	Average speed	
	Vessel utilization 75%	400 km	Cost / Rs. per ntkm	Cost / Rs. per tour	Rail fee	330 km	Cost / Rs. per ntkm	Cost / Rs. per tour			Rs. per passage	75%	330 km	Rail fee	Cost / Rs. per ntkm	Cost / Rs. per tour	Rs. per passage	400 km						Cost / Rs. per ntkm	Cost / Rs. per tour
	Transport volume [t]																								
2,000 t Barge	1,500	0.77	464,099	incl.	0.77	382,882	846,981	1,423,500	1,500	0.59	294,122	incl.	0.59	356,512	650,635	1,423,500	1,497,615	2,847,000	1,349,385	122	5.1				
3,000 t Barge	2,250	0.66	591,715	incl.	0.66	498,165	1,079,880	2,135,250	2,250	0.52	389,543	incl.	0.52	472,174	861,717	2,135,250	1,941,597	4,270,500	2,328,903	122	5.1				

Source: Azzura Marine Liners Pvt Ltd; findings market surveyors; Eastern Navigation Pvt Ltd.; calculations by Consultants

Another rail connection is the transport of fertilizer from Kakinda Sea Port to Bhagalpur Rail Station. This is an OD pair elaborated by the market surveyors. The distance between Kakinda Sea Port and Bhagalpur is almost 5,000 km. It provides the same gauge over the complete distance.

Table 69: Costs and earnings per trip for IWT transport of fertilizer between Kakinada and Bhagalpur

Rail II	Fertilizer								
	Volume in 2014 4,988	Section: Kakinda Port - Bhagalpur			no further section needed		Costs total	Earnings 2.3 Rs. per ntkm	Total Margin in Rs.
	1,417 km	Rail fee	Cost / Rs. per ntkm	Cost / Rs. per trip	Rs. per passage				
2,200 t train	1,823	0.94	2,440,368	n.a.			6,588,994	16,503,771	9,914,776

* average load per IR train 1,823 t (2012/13)

Source: IR "Adjustments in Base Freight Rate effective form 01.04.2015"; findings market surveyors; calculations by Consultants

The following figure shows the connection between Kakinda and Bhagalpur.

Figure 50: Rail connection Kakinda to Bhagalpur

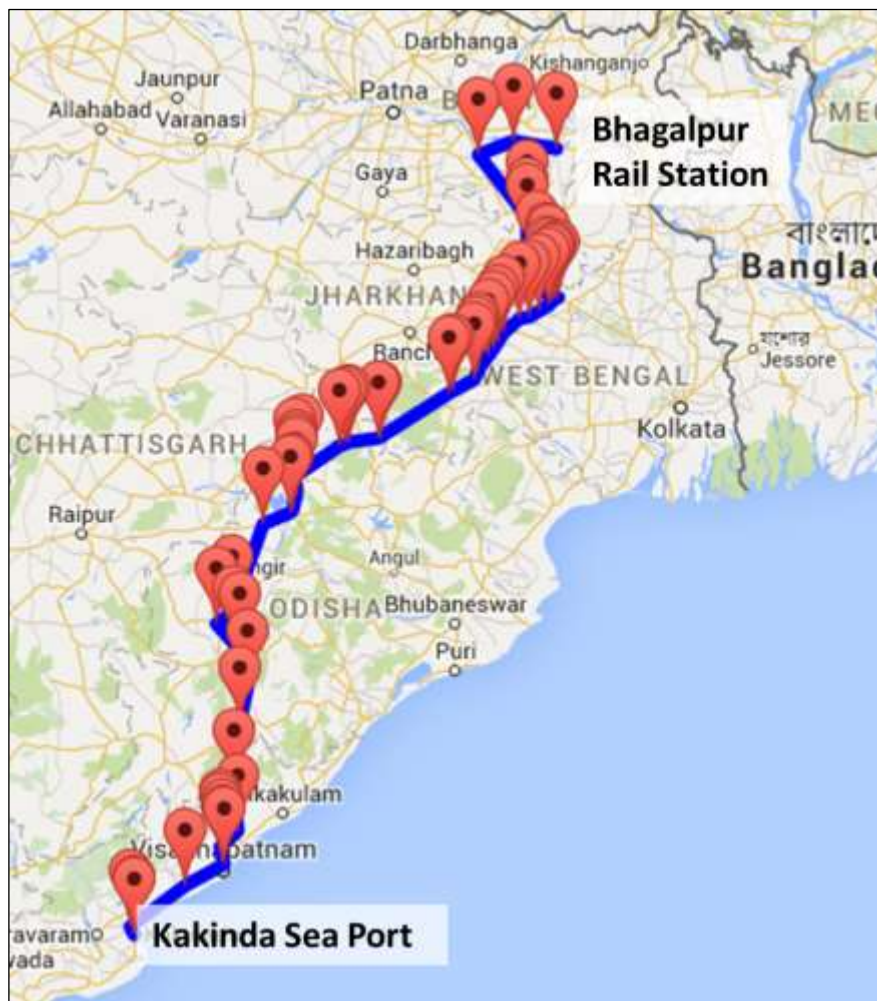

Source: Google Maps under <http://rbs.indianrail.gov.in/ShortPath/Map.jsp>; consultant's illustration

Table 70: Costs and earnings per trip for IWT transport of coal/cement between Kolkata and Barh

IWT	Dry Bulk / Coal								Dry Bulk / Cement								Whole Trip							
	Upstream				Downstream				Upstream				Downstream				Costs		Earnings		Margin		Average speed	
	Vessel utilization	Section: Kolkata to Farakka		Section: Farakka to Barh	Costs total	Earnings	Vessel utilization	Section: Barh to Farakka		Section: Farakka - Kolkata	Costs total	Earnings	Costs	Earnings	Costs	Earnings	Margin	Average speed	travel time					
75%	400 km	Farakka Lock	330 km	Rs. per ntkm	Rs. per tour	75%	330 km	Farakka Lock	400 km	Rs. per ntkm	Rs. per tour	Rs. per ntkm	Rs. per tour	Rs. per ntkm	Rs. per tour	Rs. per ntkm	Rs. per tour	[h]	in days					
2,000 t Barge	1,500	0.77	464,099	incl.	0.77	382,882	846,981	1,423,500	1,500	0.59	294,122	incl.	0.59	356,512	650,635	1,423,500	1,497,615	2,847,000	1,349,385	122	5.1			
3,000 t Barge	2,250	0.66	591,715	incl.	0.66	488,165	1,079,880	2,135,250	2,250	0.52	389,543	incl.	0.52	472,174	861,717	2,135,250	1,941,597	4,270,500	2,328,903	122	5.1			

Source: Azzura Marine Liners Pvt Ltd; findings market surveyors; Eastern Navigation Pvt Ltd.; calculations by Consultants

Although in the previous sections three types of barges have been described in this example only the 2,000-tons and the 3,000-tons barges are mentioned. As natural draft restrictions are expected during regular operations the utilization rate per barge has been assumed being 75%. The distance between Kolkata and Barh has been divided into two sections which are Kolkata-Farakka (with its lock) and Farakka- Barh vice-versa respectively. The charges for the usage of the lock are already included in the cost per ton-km. The distance via waterway from Kolkata to Barh is about 730 km. As described in the previous chapters the costs per ton-km differ depending on the direction which could be upstream or downstream. The net travel time

needed for a whole round trip from Kolkata to Barh and back has been calculated being 122 hours which is obviously longer than by road or rail.

Table 71: Comparison of transport modes concerning transport of 3,000 tons of cargo between Kolkata and Barh

All modes	Capacity of vehicle/unit [t]	Section: Kolkata - Barh 1,500 t of coal					Section: Barh - Kolkata 1,500 t of cement					Kolkata - Barh - Kolkata 3,000 t of cargo		
		Number of trips	Cost / Rs. per trip	Total cost	Total earnings	Profit	Number of trips	Cost / Rs. per trip	Total cost	Earnings	Profit	Total cost	Earnings	Profit
IWT	1,500	1.0	846,981	846,981	1,423,500	576,519	1.0	650,635	650,635	1,423,500	772,865	1,497,615	2,847,000	1,349,385
Road	24	62.5	28,094	1,755,859	2,444,700	688,841	62.5	28,094	1,755,859	2,444,700	688,841	3,511,719	4,889,400	1,377,681
Rail	1,980	0.8	953,969	722,704	1,786,275	1,063,571	0.8	953,969	722,704	1,786,275	1,063,571	1,445,407	3,572,550	2,127,143

Source IR "Adjustments in Base Freight Rate effective form 01.04.2015"; Planning Commission; Manual on Economic Evaluation of Highway Projects in India, Indian Road Congress; Azzura Marine Liners Pvt Ltd; Eastern Navigation Pvt Ltd.; findings market surveys; calculations by Consultants

The table above shows a case of 1,500 tons of coal to be transported from Kolkata to Barh and 1,500 tons of cement from Barh to Kolkata. Due to uncertain draft condition on the Farakka-Barh section, a 2,000-tons barge has been chosen for this comparison. As an overloaded truck is the only economic way to execute road transport a 24-tons truck has been chosen. For rail operations a 2,200-tons train with 90% utilization has been selected. Due to the different load capacities per trip different numbers of trips are necessary to transport the whole volume of coal and cement. For IWT one barge trip seems to be sufficient but for road transport 62.5 truck trips per direction would be necessary to transport the total amount. The train is not fully utilized per each direction. Thus, one trip is sufficient. Based on the costs and earning per ton-km mentioned in the road, rail and IWT table above the total costs for the complete transport as well as the related earnings have been calculated. The mentioned earnings are equal to the amount the customer has to pay for transport services. As freight rates for IWT has been defined on purpose lower than the road and rail rates the actual margin for IWT is also the lowest. Earnings generated by road operations are the highest of the three transport modes. But the costs are also the highest. Finally the remainder profit for road transport equals almost the profit of IWT. But the total costs for an IWT are less than half of the costs generated by road transport. Due to the quite costly upstream operations of IWT the total transport costs are higher than for rail transport. In the end from the customer's point of view the IWT provides the lowest rate. From the operator's point of view rail generates the highest profit.

8.2 Unit cost of transportation for IWT as against rail and road

In general, comparing the three transport modes, transport by truck is most expensive, transport by train is less expensive (in Germany approximately 4.1% of the unit cost compared to those by truck regarding fuel consumption) and, finally, IWT is even more economical (approximately 1.9% of the unit cost compared to those by truck regarding fuel consumption). But this general comparison of unit costs constitutes a rather theoretical exercise as transport unit costs mainly depend on the location as well as availability of traffic infrastructure of the origin and the destination.

As a result of comparison, it is obvious that railway transport and IWT are both more economical than road transport. But when it comes to making decision between rail transport and IWT, it is necessary to consider other measures as well. The location of the origin and its

traffic infrastructure are important for the cost-efficiency and success of the IWT. Once an industry moves closer to, or ideally onto the banks of, the NW-1, IWT becomes more attractive.

Similar to road and railway transport, unit cost per ton-km decreases in inland shipping on longer transport distances. The unit costs of inland shipping also depend on the usage of the potential vessel draft (construction draft). It has been assumed that a vessel with a higher load capacity also request a lager draft. The trucking costs are quite high in comparison to the elaborated road transport rates. If the calculations concern the regular depreciation as well as the official maximum loading capacity economic truck operations do not seem possible for certain commodities like dry bulk or bagged cargo. This indicates that road transport in India is very likely to be performed with old and completely depreciated trucks in combination with heavy overweighed cargo loads.

8.2.1 Case I and II: 16-tons and 24-tons capacity trucks

Due to this finding, two truck cost calculations are mentioned in the following table. One calculation is based on the adherence of the maximum allowed loading capacity of 16 tons per truck and the second one concern an overloading rate of 50% ending up with a utilized loading capacity of 24 tons.

Table 72: Unit cost comparison of transport modes (Rs per ton-km)

Cost Component	Rail Cost Electrified; double line; ghat terrain	Truck Costs		Various Barge Sizes on Upstream versus Downstream Voyage					
		16-tons capacity	24-tons capacity (overloaded)	1000 tons		2000 tons		3000 tons	
				Upstream	Downstream	Upstream	Downstream	Upstream	Downstream
Fuel & Oil	0.23	1.87	1.25	0.51	0.25	0.30	0.15	0.22	0.11
Labor & Staff	0.15	0.15	0.10	0.03	0.01	0.02	0.01	0.01	0.01
Terminal	0.04	-	-	0.31	0.31	0.31	0.31	0.31	0.31
Repair & Maintenance	0.04	0.09	0.06	0.04	0.04	0.02	0.02	0.01	0.01
Overhead	0.05	0.32	0.21	0.06	0.03	0.03	0.02	0.02	0.01
Capital	0.43	0.27	0.18	0.10	0.10	0.05	0.05	0.03	0.03
Tolls / User Charges	n.a.	0.34	0.23	0.05	0.05	0.05	0.05	0.05	0.05
Total Costs per ntkm	0.94	3.03	2.02	1.08	0.79	0.77	0.59	0.66	0.52

Source: Azzura Marine Liners Pvt Ltd, Kolkata, October 2015; Eastern Navigation Pvt Ltd.; Manual on Economic Evaluation of Highway Projects in India, Indian Road Congress, IRC:SP:30-2009

For the 1,000 tons barge a diesel engine of 2x 345 BHP has been assumed as a suitable motorization. This engine stands for fuel consumption per hour of about 70 liters. The calculation of the 2,000 tons barge is based on the assumption to consider a 2x 400 BHP diesel engine. This kind of engine consumes around 90 liters of diesel per hour. The 3,000 tons barge is equipped with a 2x 500 BHP aggregate and consumes 100 liters of diesel per working hour.

As the unit cost for a total round-trip also depends on the freight volume on the return trip, the spread has been calculated for two cases: empty return voyage / full capacity use also on the return trip. The figure below shows results for a big motor vessel (110 x 11.45 m). The costs per ton-km do decrease by around 53% if the effective draft of a vessel could be increased from 2.0m to 3.4m. The interesting range of drafts of the NW1 is between 2.5m and 3.0m. In this range the reduction of unit costs by around 13% are very likely.

Figure 51: Average depression of IWT unit costs per ton-km according to effective draft (Europe)

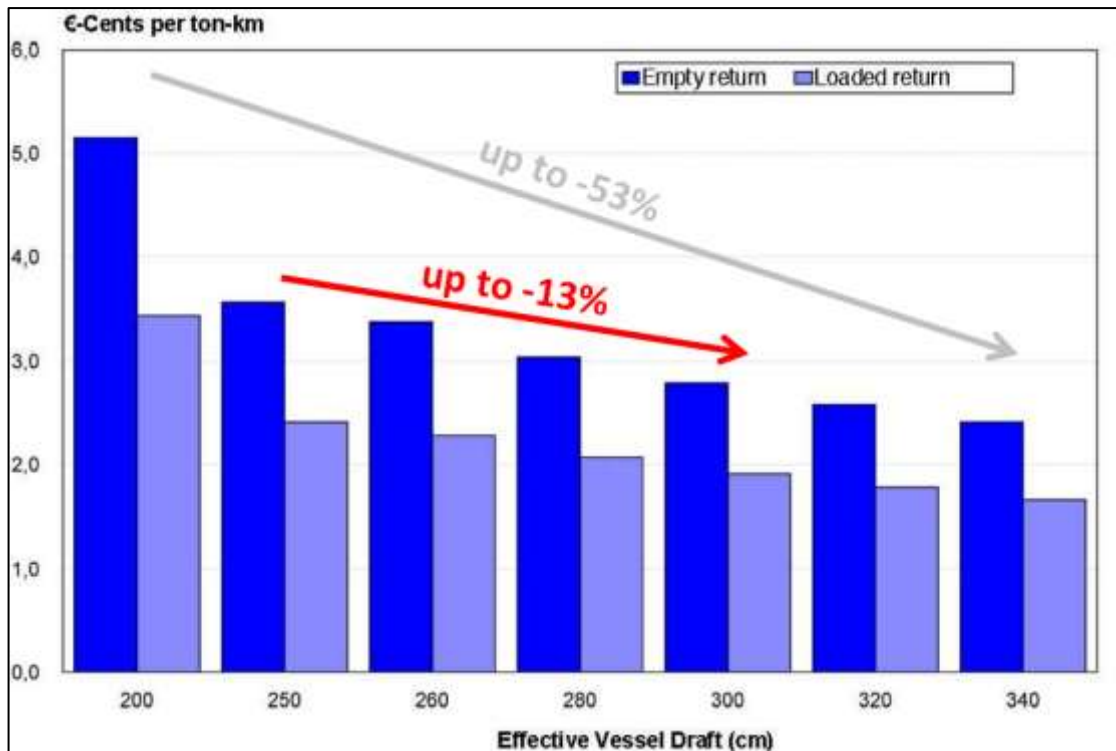

Source: PLANCO Consulting GmbH *Economical and Ecological Comparison of Transport Modes: Road, Railways, Inland Waterways*, Essen/Germany, November 2007, p. 32

The level of transport costs on inland waterways depends heavily on the size of vessels its draft respectively and on the volume of cargo carried. Both parameters are influenced by the physical characteristics of the used waterway. Comparative cost calculations per ton-km reflect the cost depression according to typical vessels and effective vessel draft.

For all three transport modes, the cost of allocating the required vehicle for a given transport task and the cost of loading and unloading are largely independent of the transport distance. Hence, the cost per ton-km decreases with the distance. For a given transport distance, the unit cost depends on the loading capacity and on the capacity utilization of vehicles employed. Different commodities have different loadability, resulting in commodity-specific transportation costs. The cost per ton-km of loaded vehicles will be lower for higher freight volumes and the cost per ton-km for a roundtrip will be lower with a lower share of empty voyages. Thus, transport modes which are able to transport high cargo volumes (in tons) are actually more suitable to transport high volume heavy goods. Due to this bulk cargo like for example coal, fertilizer, and cement are commodities being predestinated to be transported by IWT or rail on the long-distance travel. Additional transport cost for the "last mile" do occur.

Operating costs are further divided into time-related and running costs. Time-related costs include expenditure such as capital, crew salary, insurance, taxes (goods, roads), overheads, etc. which are to be incurred by the operator irrespective of the vehicle movement. Similarly, the costs borne by the operator relating to vehicle movement are considered as running costs, i.e. fuel, mobile oil, repairs and maintenance (all types), tyre & tubes, toll charges, trip allowances or 'Bhatta' to the crew and other wayside expenses.

According to comparative calculations for selected routes (O/D pairs) in Germany, inland shipping has the lowest specific energy consumption of the three considered modes. On seven of eight selected bulk freight routes, and on all chosen container routes, inland ship transport has lower energy consumption than railway transport. The highest energy consumption occurs generally with truck transport.

In order to show the range of costs concerning commodities as well as transport modes the following two tables are presented. The tables also show a probable margin per transport mode. The main difference between both tables is the assumption of utilized load capacity for road transport. As described above the regular assumption for road transport lead to losses in bulk and bagged cargo transport. Thus, the upper table considers a maximum load capacity of 16 tons per truck and the lower considers a maximum load capacity of 24 tons.⁵¹

Table 73: Comparison freight tariffs and costs on Haldia-Farakka sector (Case I: 16 tons per truck)

Rs. per ntkm	Railway					Road (16 t cargo per truck)					IWT (3,000 dwt vessel)				
	Haldia MMT	Kolkata GRT	Total Sector	Costs	Difference Tariffs- Costs	Haldia MMT	Kolkata GRT	Total Sector	Costs	Difference Tariffs- Costs	Tariffs* NW-1	Costs Upstream	Costs Downstream	Difference: Tariffs - Costs Upstream	Difference: Tariffs - Costs Downstream
Dry bulk	2.14	1.99	2.07	0.94	1.12	1.95	2.00	1.98	3.03	-1.05	1.0	0.66	0.52	0.32	0.45
Liquid bulk	n/a	n/a	n/a	n/a	n/a	n/a	4.00	4.00	3.03	0.97	4.0	0.66	0.52	3.34	3.48
Bagged	n/a	3.31	3.31	0.94	2.37	2.39	2.28	2.34	3.03	-0.69	1.1	0.66	0.52	0.44	0.58
General	n/a	n/a	n/a	n/a	n/a	n/a	n/a	n/a	n/a	n/a	n/a	n/a	n/a	n/a	n/a
Neo-bulk	2.50	3.72	3.11	0.94	2.17	n/a	3.11	3.11	3.03	0.08	1.4	0.66	0.52	0.74	0.88
Ro-ro	n/a	32.40	32.40	0.94	31.46	n/a	n/a	n/a	n/a	n/a	7.0	0.66	0.52	6.34	6.48
Container	n/a	n/a	n/a	n/a	n/a	7.95	6.33	7.14	3.03	4.11	4.5	0.66	0.52	3.84	3.98

*proposed

Source: Based on Planning Commission “Total Transport System Study”; IWT freight tariffs according to market survey interviewees; Consultant’s depiction

Table 74: Comparison freight tariffs and costs on Haldia-Farakka sector (Case II: 24 tons per truck)

Rs. per ntkm	Railway					Road (24 t cargo per truck)					IWT (3,000 dwt vessel)				
	Haldia MMT	Kolkata GRT	Total Sector	Costs	Difference Tariffs- Costs	Haldia MMT	Kolkata GRT	Total Sector	Costs	Difference Tariffs- Costs	Tariffs* NW-1	Costs Upstream	Costs Downstream	Difference: Tariffs - Costs Upstream	Difference: Tariffs - Costs Downstream
Dry bulk	2.14	1.99	2.07	0.94	1.12	1.95	2.00	1.98	2.02	-0.04	1.0	0.66	0.52	0.32	0.45
Liquid bulk	n/a	n/a	n/a	n/a	n/a	n/a	4.00	4.00	2.02	1.98	4.0	0.66	0.52	3.34	3.48
Bagged	n/a	3.31	3.31	0.94	2.37	2.39	2.28	2.34	2.02	0.32	1.1	0.66	0.52	0.44	0.58
General	n/a	n/a	n/a	n/a	n/a	n/a	n/a	n/a	n/a	n/a	n/a	n/a	n/a	n/a	n/a
Neo-bulk	2.50	3.72	3.11	0.94	2.17	n/a	3.11	3.11	2.02	1.09	1.4	0.66	0.52	0.74	0.88
Ro-ro	n/a	32.40	32.40	0.94	31.46	n/a	n/a	n/a	n/a	n/a	7.0	0.66	0.52	6.34	6.48
Container	n/a	n/a	n/a	n/a	n/a	7.95	6.33	7.14	2.02	5.12	4.5	0.66	0.52	3.84	3.98

Source: Based on Planning Commission “Total Transport System Study”; Market Survey Findings; Consultant’s depiction

These examples are based on IWT data related to the Haldia-Farakka section and by this do not include any usage fees for the lock. The second table also shows that even with a higher load capacity the truck operations for dry bulk within the Haldia-Farakka section could not be executed economically.

8.2.2 Case III: Rajmahal Coal Mines

In general, comparing the three transport modes, transport by truck is most expensive, transport by train is less expensive (approximately 4.1% of the unit cost compared to those by truck regarding fuel consumption) and, finally, IWT is even more economical (approximately 1.9% of the unit cost compared to those by truck regarding fuel consumption). But this general comparison of unit costs constitutes a rather theoretical

⁵¹ For cost details per element and transport mode consider Table 21 for railway, Table 24 for road and Table 25 for IWT

exercise; practically, transport unit costs depend on the location and traffic infrastructure of the origin and the destination.

As an example, one may have a closer look at the *Rajmahal Coal Mines* located in Lalmatia / Jharkhand. The distance between these coal mines and Varanasi via road is approximately 583 km (via NH 133 and NH 2). A direct access for coal to be transported by rail is provided in Lalmatia (via Farakka) with a total distance of approximately 764 km to Varanasi. The Ganges River (access through Sahibganj / Jharkhand) is approximately 57 km away from the coal mines via road (via NH 133 and NH 80) and approximately 190 km away via rail. The distance between Sahibganj and Varanasi via NW 1 is 747 km.

Figure 52: Location of Rajmahal Coal Mines



Source: www.map.de; changes made by HPC Hamburg Port Consulting GmbH, UNICONSULT Universal Transport Consulting GmbH, 2015

When assessing the overall unit costs for transporting coal from the *Rajmahal Coal Mines* in Lalmatia to Varanasi, the relative unit-cost difference transported by train compared to truck transport is differing from theory. Although the train ride from Rajmahal to Varanasi has to be routed via Farakka it results in 40.9% of the truck transport costs which are set as 100%. Whereas for IWT coal must be transported to the river first before it can be transported to Varanasi by vessel due to the location of the coal mines and by this an additional handling is generated. Either this first transport link to Sahibganj would have to be covered by truck or by train. The transport chain of truck and IWT results in 42.5% of the compared costs for transporting the whole cargo volume by trucks from Rajmahal to Varanasi. The case of combining rail and IWT ends up at 42.9% of costs in comparison to 100% truck transport. The utilization of two transport modes makes an additional handling of cargo necessary. In this particular situation, additional costs are implied by the handover from train/truck to a vessel.

Table 75: Comparison of transport cost of different supply chain between Rajmahal and Varanasi

Road / IWT		Distance		Cargo volume	Cost			Percentage of pure road transport
From	To	By road	By IWT		per ntkm	per section	per unit	
Rajmahal Coal Mine	Sahibganj	57 km		2,250 t	3.03 Rs	388,257 Rs		
Sahibganj	Varanasi		747 km	2,250 t	0.77 Rs	1,300,057 Rs		
Total cost						1,688,314 Rs	750.4 Rs / 1 t coal	42.5%

Rail / IWT		Distance		Cargo volume	Cost			Percentage of pure road transport
From	To	By rail	By IWT		per ntkm	per section	per unit	
Rajmahal Coal Mine	Sahibganj	190 km		2,250 t	0.94 Rs	403,864 Rs		
Sahibganj	Varanasi		747 km	2,250 t	0.77 Rs	1,300,057 Rs		
Total cost						1,703,921 Rs	757.3 Rs / 1 t coal	42.9%

Road		Distance		Cargo volume	Cost			Percentage of pure road transport
From	To	By road			per ntkm	per section	per unit	
Rajmahal Coal Mine	Varanasi	583 km		2,250 t	3.03 Rs	3,971,118 Rs		
Total cost						3,971,118 RS	1,764.9 Rs / 1 t coal	100.0%

Rail		Distance		Cargo volume	Cost			Percentage of pure road transport
From	To	By rail			per ntkm	per section	per unit	
Rajmahal Coal Mine	Varanasi	764 km		2,250 t	0.94 Rs	1,623,958 Rs		
Total cost						1,623,958 RS	721.8 Rs / 1 t coal	40.9%

Source: Consultants

As a result of comparison for this example, it is obvious that railway transport and IWT (regarding both alternatives for the first stretch) are both more economical than road transport. But when it comes to making decision between rail transport and IWT, it is necessary to consider other measures as well.

The example shows that the location of the origin and its traffic infrastructure is important for the cost-efficiency and success of the IWT. Once an industry moves closer to, or ideally onto the banks of, the NW 1, IWT becomes more attractive.

8.2.3 External costs

External costs are defined as non-compensated impacts by transport agents on not involved third parties. 'External' means: the negatively affected third party receives no (no full) compensation. In the transport sector external effects occur in following fields:

- Transport safety/Accidents: Of all economic costs caused in Germany by freight transport accidents in the period 2000 to 2005, 96.9% are due to trucks, 2.0% to railways and 1.1% to inland shipping.
- Noise: The difference of noise emissions per unit of freight, between road and rail, measured along road resp. railway lines is only small. Inland shipping causes only lower emissions, with a difference representing 50% lower immission loads as perceived by people.
- Climate gases: In Germany, calculations were prepared for selected O/D pairs. Clearly, the highest specific CO² emissions are caused by road trucks. This remains valid if the additional collection and distribution transport by trucks is considered for containers carried by railways or ships on their main route section. For five of eight analyzed bulk freight transport cases, inland shipping causes lower CO² emissions than railways.
- Air pollution: Electricity-powered railway transport causes clearly lower pollutive emissions (nitrogen oxide, sulfur dioxide, non-methane carbon hydrides, carbon monoxide and particles) than road and inland ship transport. Accordingly, on all selected transport routes the external costs of air pollution caused by railway transport are significantly lower

than those of competing modes. However, exhaust emissions of electricity-powered railways depends on the structure of primary energy used for electricity generation. When comparing inland shipping with road transport, there is a clear advantage for ship transport.

- Landscape dissection and area consumption: While roads and railways serve exclusively transport purposes, almost fully sealing soils, waterways remain habitats for aquatic fauna – though sometimes minor sealing of waterway beds and shoulders is required. These habitats can have a highly positive ecological value. Waterways also serve other purposes than transport (e.g. water sports, energy generation, fishery). These qualitative aspects show a clear advantage of waterways against other modes.

The following figure is supposed to show the likely scale of external costs. Although published in 2007 and based on German condition, the figure gives an impression of the proportionality of the distribution of the external costs generated by cargo transport.

Figure 53: Average external costs by transport mode (in € per 1,000 tkm)

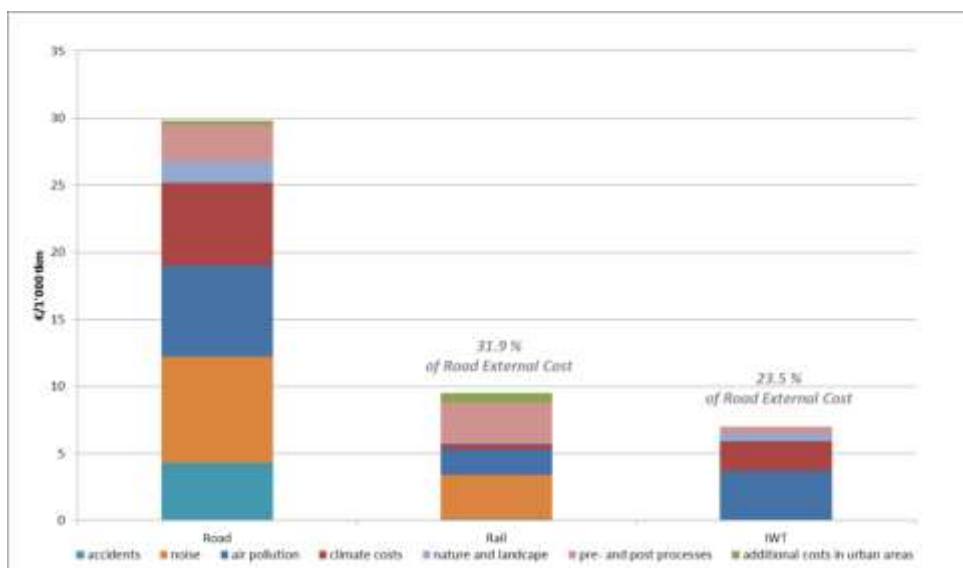

Source: based on Infras 2007; Consultant's illustration; http://www.ioew.de/uploads/tx_ukioewdb/IOEW_SR_194_Stand_und_Potenziale_der_Elbe-Binnenschifffahrt.pdf

Table 76: Average external costs by mode (in € per 1,000 tkm)

€/per 1,000 tkm	Road	Rail	IWT
accidents	4.3	0.1	0.0
noise	7.9	3.3	0.0
air pollution	6.8	1.9	3.7
climate costs	6.2	0.4	2.2
nature and landscape	1.6	0.1	0.6
pre- and post processes	2.7	3.0	0.5
additional costs in urban areas	0.3	0.7	0.0
Total	29.8	9.5	7.0

Source: Consultants

On Germany's bulk freight routes, the external costs of inland shipping are even lower reaching an average of 70% of those for railway transport, and a staggering 17% of those for road transport.

9 Traffic Forecast – General

9.1 Background indicators

Provided that the IWT infrastructure develops sufficiently, the cargo potential on the existing five national waterways is projected to increase to about 47 MMT by 2019-20 and to 92 MMT by 2031-32. The composition of projected cargo is expected to be similar to the current structure comprising of coal, construction material, agriculture & forest products, and others, with coal forming the bulk of the volume.

Coal is the most important and abundant fossil fuel in India. Coal and lignite together account for about 53.65% of the country's energy need. Considering the limited reserve potentiality of petroleum and natural gas, eco-conservation restriction on hydro-electric project and geo-political perception of nuclear power, coal will continue to occupy centre-stage of India's energy scenario. Natural gas is fast emerging as an alternative source of energy. However, in the foreseeable future coal-based thermal power plants will remain the mainstay of electricity generation in the Project region. The nationwide reserve capacity for coal production increased from tons 264 billion in 2007-08 to tons 293 billion in 2011-12 showing a growth rate of 2.64% per annum. The reserve capacity for lignite production increased from tons 39 billion in 2007-08 to tons 42 billion in 2011-12 showing a growth rate of 1.9% per annum.

Major freight-generating sectors such as power, steel and cement industries and consequently coal - both domestically mined and imported - are poised for a massive expansion. Coal constitutes close to 45% of India's total railways' freight movement. Although part of the coal movement may shift to non-rail alternatives (e.g. pit-head or portbased power plants relying on merry-go-round or conveyor belt systems), concerns on pollution overload and energy security at state/regional level would lead to continued expansion of thermal generation capacity across the country. Both the volume and lead of coal transport would increase as a result. A large part of the movement would involve linkages to new mines or ports.

Almost all economic activity requires electricity, and steel is an important input for many industries. In order to sustain a GDP growth rate of 8-10% over the next two decades, it is estimated the production of electrical energy will need to increase 3.5 times from 1,105 BU now to 3,860 BU by 2031-32. As coal is expected to remain the dominant fuel for the power sector, the requirement for coal is expected to grow correspondingly. Utilization of domestic coal is expected to grow by about 2.5 times; from about 440 MMT in 2011-12 to 1,110 MMT in 2031-32. Its use in the power industry will be limited by the amount produced and imports will bridge the deficit and grow much faster; by almost five times; from 73 MMT in 2011-12 to 355 MMT by 2031-32.

Overleaf *Table 77* indicates the generating capacity of electricity in the four riparian states.

Table 77: State-wise installed generating capacity of electricity

State	Installed generating capacity of thermal electricity (GWh)	Per-capita electricity consumption (Kwh)
Bihar	430	133.61
Jharkhand	1,550	790.20
Uttar Pradesh	7,117	449.89
West Bengal	6,484	563.78
Total India	131,603	883.63

Source: All India Electricity Statistics published by Central Electricity Authority, M/o Power, 2012

Low per-capita electricity consumption, compared to India as a whole, in the state of Bihar and, to a certain extent, even in U.P. indicates significant material requirements in general and a high potential for coal transports in particular upstream of the Farakka Barrage. These needs could be covered, at least in part, by shipping cargo on the NW-1.

9.2 Impact of background economic growth on future transport demand

In the decades before and after economic reforms, total freight traffic grew at a pace broadly comparable to GDP growth. Below Table 78 shows the correlation between GDP and traffic growth:

Table 78: Freight elasticities with respect to GDP

Years	1950-51 to 1970-71	1970-71 to 1990-91	1990-91 to 2004-05	1950-51 to 2004-05	2004-05 to 2011-12
Rail Freight Traffic Elasticity	1.4	0.8	0.6	0.9	0.9 ^A
Road Freight Traffic	3.1	2.0	1.1	2.0	1.4 ^E
Total Freight Traffic	1.8	1.3	0.9	1.3	1.2 ^E

Note: ^A Actual Elasticity

^E Estimated Elasticity

Source: NTDPC Research

Road freight traffic which grew at a slower rate than GDP prior to 1991, increased at a higher rate subsequently. The trend for rail traffic was exactly the opposite. Total freight traffic grew parallel with GDP.

The intensity of steel use in the economy is expected to increase. So requirements for steel will grow faster than the growth of the economy from 73 MMT in 2011-12 to 495 MMT in 2031-32; almost an eightfold increase. Keeping in mind that a ton of finished steel requires three to four tons of raw material, the transport requirements for the steel industry will be huge; growing from 600 MMT in 2011-12 to about 2,230 MMT in 2031-32.

The transport requirements for the power and steel industry are expected to grow from about 900 MMT now to 3,700 MMT in 2031-32. While POL and natural gas will also grow, most of the transport for these commodities will be carried out through pipelines. Some POL will be transported by rail, but the volumes will be very small and are not expected to impact the rail network much. However, it will have a huge impact on waterway cargo traffic. It already has

the largest share (38%) of sea port traffic that will increase by over 2.5 times from about 330 MMT in 2011-12 to 865 MMT in 2031-32.

9.3 Freight volume growth as expected by producers and operators

Producers interviewed in the Haldia-Farakka sector expressed their expectations as to short-term volume growth of their commodities. Below *Table 79* summarizes the weighted averages of growth expectations:

Table 79: Growth expectations of commodity volumes

Commodity Group	Expected annual change (%)
Thermal Coal	5
Coking Coal	8
Pet Coke	8
Manganese Ore	10
Fly Ash	5
Stone Chips	5
Steel / Iron	6
(Silica) Sand	5
Limestone	6
Fertilizer (Urea)	5
Raw Sugar	10
Food Grains	5
Plastic Granules	5
Steel Wire / Girder	9
Cement & Concrete	7
Straight Run Naptha	10
Motor Spirit, Diesel & Kerosine	10
Agro-Equipment	5
Automobiles	5
Containers	10

Source: Consultants' Market Survey, August-October 2015

These growth expectations, although being subjective, serve as a reliable forecast indicator until about the end of this decade, as producers should have a good outlook on their commodity's perspectives. The above-expressed growth expectations vary between 5% and 10%, with industrial inputs at the lower, and consumer goods at the higher, end.

Subjective growth expectations will be compared against objective indicators such as GDP growth forecasts.

10 Traffic Forecast – on O/D Routes

The following traffic projections consider various development stages of the NW-1

10.1 Methodology and future trends

10.1.1 Overview of the forecast model

The Consultants have used their integrated forecast model determining the freight flows on the basis of the collected origin-destination pairs (O/D-pairs) from base year 2015 until 2045. The model combines:

- modal shift decisions through a comparison of the current transport mode (road/rail) with alternative IWT routes based on quantitative (generalized cost) as well as qualitative parameters (advantages of IWT transport);
- traffic forecasts based on trend analyses for the relation of GDP (in terms of real prices) respectively population growth and traffic volumes (in terms of tonnage) on the NW-1.

Figure 54: Methodology of the forecast model

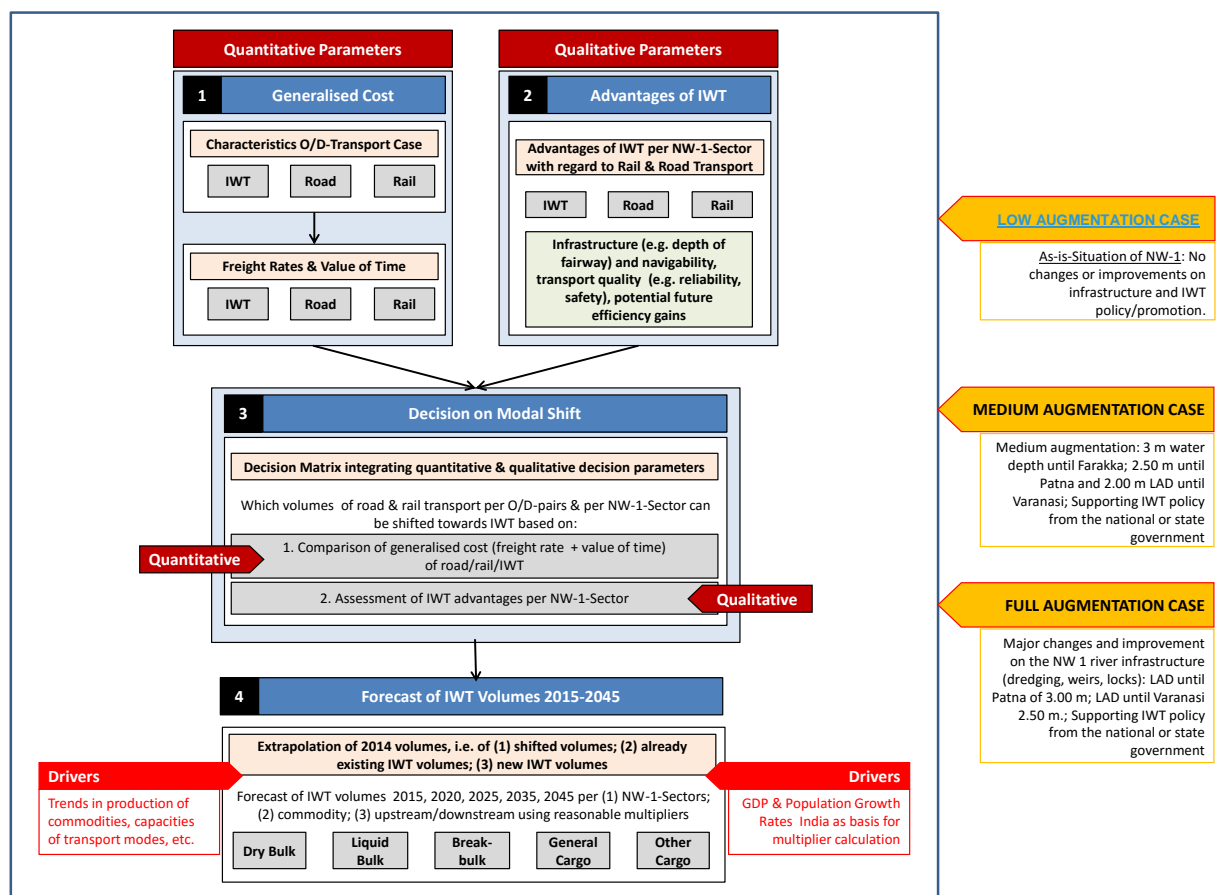

Source: Consultants, 2015

Three different scenarios applied for the O/D-pairs traffic forecast (as depicted in the following table) differ mainly in terms of the infrastructural extension/augmentation of the NW-1:

- Low Augmentation Case (LAC),
- Medium Augmentation Case (MAC),
- Full Augmentation Case (FAC).

Technical improvements would already be introduced under the LAC, in that the NW-1 will gradually be covered through electronic night navigation (based on global positioning). Also, present obstructions such as low-lying bridges and very sharp bends would be improved.

Table 80: Transport model scenarios Model Scenarios

Scenario	Description
Low Augmentation Case	No changes or improvements on infrastructure and IWT policy/promotion: Construction of Multi-modal Terminals at Haldia, Kolkata, Tribeni, Sahibganj, Doriganj and Ramnagar/Varanasi; Regular growth rates in the IWT based on macroeconomic growth rates and regional economic development
Medium Augmentation Case	Medium changes and improvements on infrastructure: Augmentation of NW-1 water depth: 3.0 m least-available depth (LAD) until Barh; 2.5 m until Buxar and 2.2 m LAD until Varanasi; Supporting IWT policy from the national or state government; Implemented IWT promotion concept to market the quality and services of IWT; Construction of Multi-modal Terminals at Haldia, Kolkata, Tribeni, Sahibganj, Doriganj and Ramnagar/Varanasi; Regular growth rates in the IWT based on macroeconomic growth rates and regional economic development
Full Augmentation Case	Major changes and improvement on the NW 1 river infrastructure (dredging, weirs, locks): LAD until Buxar of 3.0 m; LAD until Varanasi 2.5 m; Supporting IWT policy from the national or state government; Implemented IWT promotion concept to market the quality and services of IWT; Construction of Multi-modal Terminals at Haldia, Kolkata, Tribeni, Sahibganj, Doriganj and Ramnagar/Varanasi; Regular growth rates in the IWT based on macroeconomic growth rates and regional economic development

Source: Consultants, 2015

According to the fact that decisions for shifting transport volumes from land transport towards inland-waterway transport (IWT) are multifaceted, the forecast model has two main pillars indicating the quantitative and qualitative decision criteria:

- *Generalized cost comparison for O/D-pairs:* The potential future traffic on the NW-1 is mainly driven by volumes divertible from existing road and rail transport to IWT in regions along the NW-1 (approximately 200 km each side of the river). One important criteria for that decision of shippers are the generalized cost (freight costs plus value of time) which arise per transport. Therefore, the analysis matrix evaluates the freight rates and travel times of existing land transport as compared to freight rates and travel times that would occur if this actual transport case (O/D-pair) would be shifted towards IWT. The calculation is based on collected market data and is differed in freight rates per cargo packaging form (dry bulk, bagged cargo, neo-bulk/general cargo, ro-ro, container and liquid bulk).
- *Analysis of advantages of IWT:* With regard to each O/D-pair, the Consultants include their expert estimations whether IWT will have an advantage against rail and road in terms of,

inter alia, infrastructure (navigability, especially draft of fairway per NW-1-sector of the O/D-Pair), transport quality (reliability, speed), as well as potential future efficiency gains (expected improved transport on IWT). This qualitative advantage may compensate a small cost advantage of competing transport modes.

The transport model integrates these two views on modal shift, namely the quantitative (freight rate and time) and the qualitative (IWT advantages towards competing transport modes) perspective. Combining both pillars, it calculates whether and when the corresponding transport volume per O/D-pair could be diverted to NW-1.

The applied model results in a forecast of future demand of freight transport volumes on the NW-1 based on a large number of transport cases (O/D-pairs). In total, the future traffic numbers on the NW-1 result from the following sources:

- Already existing IWT transport cases (O/D-pairs) for certain commodities;
- Existing road and rail transport cases (O/D-pairs) for certain commodities that can be diverted towards the NW-1 based on the cost-ratio calculation between IWT and land transport and based on quality advantages of IWT compared to the competing land transport modes;
- Future coal import volumes for new thermal power plants that are expected to be transported via IWT.

Collected base volumes that are divertible to IWT are then extrapolated to the forecast horizon 2045, based on growth rates collected from market actors as well as a forecast of the general market dynamics elaborated by the Consultants.

10.1.2 Evaluation of modal shifts

The evaluation of modal shifts is conducted for each O/D-pair based on the following steps.

1. Transport Case Description and Calculation of Generalized Cost:

Based on the collected market data, O/D-pairs are listed in the model with the shipped commodity type, cargo packaging form, current transport mode, location of producers and users, transport distances and time, volumes of base year 2014, and with the freight rates. Based thereon, the generalized cost per ton is given as total freight rate per ton plus value of the travel time. This data has been collected through conducting on-site market research using questionnaire and personal interview methodology with shippers, consignees and industry companies in a corridor of 200 km each side of the NW-1.

For each O/D-pair, the model further describes the following parameters under the assumption that it is routed via IWT (corresponding with the real case if already today transported via IWT, or else a hypothetical route assumed by the Consultants):

- Entry and exit point of transport on NW-1;
- Entry and exit sectors/stretchers of NW-1:
 - - Stretch 1: Haldia/Kolkata-Farakka-Haldia/Kolkata,
 - - Stretch 2: Farakka-Sahibganj-Farakka,
 - - Stretch 3: Sahibganj-Patna-Sahibganj,
 - - Stretch 4: Patna-Varanasi-Patna,

- - Stretch 5: Varanasi-Allahabad-Varanasi;
- Distinction between upstream and downstream traffic on NW-1;
- "First Mile" and "Last Mile" distances (i.e., distance origin to entry point NW-1 as well as distance exit point NW-1 to destination);
- Transport distance waterway ("river bank to river bank" – this may include waterways other than NW-1, such as the sea or other inland waterways);
- Generalized cost for the IWT route (combined freight rate plus terminal handling rates plus value of time).

2. Qualitative IWT advantages per Transport Case:

Besides the above-mentioned quantitative parameters, the transport model includes a qualitative matrix asking for each O/D-pair whether IWT will have an advantage towards competing transport modes on the corresponding stretches of NW-1 depending on low augmentation case, medium or full augmentation case. Qualitative advantages of IWT towards rail and road include transport quality criteria such as mass transportation capacity, transport safety and reliability, and opportunities for intermodal shift. Furthermore, the IWT advantage evaluation includes a consideration of possible future efficiency gains and thus transport cost reduction. In that framework, the impact of infrastructure on type of vessels and their operating costs has to be assumed (economies-of-size per vessel types which depend on fairway drafts).

Overall, the following advantages have been identified:

- Low Augmentation Case: advantage for routes within NW-1 Sector 1 (up to Farakka).
- Medium Augmentation Case: advantage for routes within NW-1 Sectors 1-3 (up to Patna).
- Full Augmentation Case: advantage for all routes.

In addition, current navigability in NW-1 Sectors 4 and 5 is considered insufficient for efficient waterway transport. As a consequence, no shift is assumed for corresponding O/D-pairs in the Low Augmentation Case.

3. Decision on Modal Shift per Transport Case:

After quantitative and qualitative parameters of the transport case have been identified, the model calculates the relative difference in generalized cost between the transport case if shifted to IWT and the current generalized cost. Depending on this relative advantage or disadvantage of the IWT route in generalized cost, as well as the qualitative advantage or disadvantage, it is evaluated whether a modal shift of the O/D-pairs' volumes takes place and, if it does, in which year.

The overleaf table shows the evaluation matrix which determines the year of shift (if any) subject to a cost advantage (-100% to 5%) of IWT, current mode (road/rail) and qualitative advantage of IWT.

Table 81: Criteria for modal shift

IWT Advantage in Generalised Cost		Road		Rail	
		Qualitative Advantage IWT		Qualitative Advantage IWT	
from	to	Yes	No	Yes	No
-100%	-10%	TRUE	TRUE	TRUE	TRUE
-10%	5%	TRUE	-	TRUE	-
5%	-	-	-	-	-

Source: Consultants, 2015

The inclination to shift to IWT increases with the advantage in generalized costs. In addition, the inclination is higher if a qualitative advantage is given for the IWT route (a qualitative advantage may even outweigh a small disadvantage in generalized costs).

10.1.3 Parameter assumptions used in the model

The following table shows the underlying parameter assumptions used in the model:

Table 82: Parameter Assumptions

Parameter Assumptions										
Freight Prices IWT										
	2015	2020	Up		Down		2035	2045		
			2025	2035	2025	2035	2045			
Dry Bulk	1.84	1.84	1.47	1.23	1.23	1.84	1.84	1.47	1.23	1.23
Bagged	1.83	1.83	1.47	1.23	1.23	1.83	1.83	1.47	1.23	1.23
Neo-bulk	1.55	1.55	1.25	1.04	1.04	1.55	1.55	1.25	1.04	1.04
General Cargo	3.51	3.51	2.88	2.46	2.46	3.51	3.51	2.88	2.46	2.46
Ro-Ro	7.22	7.22	5.89	5.01	5.01	7.22	7.22	5.89	5.01	5.01
Container	4.66	4.66	3.87	3.35	3.35	4.66	4.66	3.87	3.35	3.35
Liquid bulk	1.59	1.59	1.27	1.06	1.06	1.59	1.59	1.27	1.06	1.06
Share of Two-Way Traffic										
	2015	2020	2025	2035	2045	Speed by Mode				
Dry Bulk	0.0%	0.0%	25.0%	50.0%	50.0%	Road	Rail	IWT		
Bagged	0.0%	0.0%	25.0%	50.0%	50.0%	20.0	20.0	7.0	km/h	
Neo-bulk	0.0%	0.0%	25.0%	50.0%	50.0%					
General Cargo	0.0%	0.0%	25.0%	50.0%	50.0%					
Ro-Ro	0.0%	0.0%	25.0%	50.0%	50.0%					
Container	0.0%	0.0%	25.0%	50.0%	50.0%					
Liquid bulk	0.0%	0.0%	25.0%	50.0%	50.0%					
Base Freight Price - One-Way Traffic IWT										
	Freight	Insurance	Value of Time		Stowage Factor					
Dry Bulk	1.83	0.01	Rs/tkm	Coal	0.07	Rs/ton/h	australian	Coal, fly ash (bulk)	(m ³ /MT)	
Bagged	1.80	0.03	Rs/tkm	Construction Materials	0.17	Rs/ton/h	cement	Natural aggregates (bulk)	1.25	
Neo-bulk	1.52	0.03	Rs/tkm	Consumer Goods	1.80	Rs/ton/h		Lime stone (bulk)	0.9	
General Cargo	3.15	0.36	Rs/tkm	Project Cargo	4.45	Rs/ton/h		Fertilizer (bagged)	0.8	
Ro-Ro	6.62	0.60	Rs/tkm	Fertilizer	0.31	Rs/ton/h	DAP	Grain (bagged)	1.25	
Container	3.94	0.72	Rs/tkm	Food and Foodstuff	0.27	Rs/ton/h	wheat	Cement (bagged)	1.3	
Liquid bulk	1.58	0.01	Rs/tkm	Gas and Petroleum	0.09	Rs/ton/h	diesel	Bricks & tiles (palletted)	0.85	
				Minerals & Chemicals	0.09	Rs/ton/h	iron ore	Steel (neo-bulk)	1.0	
				Container	3.60	Rs/ton/h		General cargo (piece)	0.6	
				Vehicles	4.45	Rs/ton/h	US\$ 5000/ton	Vehicles (piece)	2.0	
								Containers (boxes)	4.2	
								Crude oil, petroleum (bulk)	2.5	
									1.0	
Terminal Handling Rate (per Handling)										
Dry Bulk	62.5	Rs/t								
Bagged	54.5	Rs/t								
Neo-bulk	142.0	Rs/t								
General Cargo	96.0	Rs/t								
Ro-Ro	37.0	Rs/t								
Container	167.7	Rs/t								
Liquid bulk	48.7	Rs/t								
Notes to calculation: Proportional to 1,000-ton barge (Barh upstream) - 2,000-ton barge (Barh downstream), multiplied by stowage factors, plus 0.01% of commodity value as insurance cover for voyage charge										
Source: Below Tables on Freight-Prices Breakup for Movement of Cargo on NW-1										
Notes to calculation: Conversion from commodity (as above) per-ton prices into hourly interest										
Source: Specific commodity prices in internet										
13% annual interest rate										
300 working days per year										
1.5 ratio first/last mile vs. main freight rate										
Notes to calculation: Average 2 days of 1,000-ton barge assumed for berthing charges; Stowage and shore-handling (by terminal) of bagged, neo-bulk, ro-ro and general cargo receive 40% rebate; Only 1/3 of 2014 dry-bulk cargo volume with 40% rebate										
Sources: (1) The Gazette of India, July 16, 2011 (Part III - Sec. 4); 13.5 tons per TEU										
(2) SS-56/Part-I and S11.3/Part-II of No. TAMM/8/2013-KOPT, 24 February 2014										
Sources: (1) http://www.jctrans.net/Register/SF.html#C ; (2) https://en.wikipedia.org/wiki/Stowage_factor , 12 March 2016										

Source: Consultants, March 2016

Three financial input figures have the most significant impact on forecast cargo volumes:

1. Freight prices (see Chapter 4.2.3 for their calculation process) modified into individual types of shipped cargo by different stowage factors, and by the shipper calculating roundtrip costs (in case of empty return voyage) and charging its insurance premium;
2. Terminal-handling rates applicable within the Kolkata Port Trust tariff (cargo handling) and IWAI terminals (wharfage); and
3. Inventory costs (depending on the voyage speed of the three transport modes, generally to the detriment of shifting potential onto the NW-1) of shipped major commodities.

Assumptions

It has been assumed that the Medium Augmentation shall be completed by 2025.

Vessel Sizes

The average vessel size of 1000MT has been assumed to ply across the stretches in 2015.

By 2017 the shallow draft vessels design will be available and accordingly the vessel size across different stretches shall increase from 1000MT to 2000MT by 2020.

The medium augmentation (MAC) shall be completed by 2025 and by then the average vessel size shall increase to 2500MT. In 2035 it has been assumed that the existing vessels of 2015 would have phased out and the average vessel size shall become 3000MT.

The vessel carrying capacity has been assumed same across NW-1 inspite of different characteristic of waterway from Haldia to Farakka and Farakka to Allahabad. The LAD in stretch between Haldia to Farakka is more but the radius of curvature of bends is limiting factor on the vessel size and not able to use tug and tow concept. Whereas the stretch between Farakka to Allahabad has lower LAD but stretches are wider, have less number of bends and with larger radius of curvature hence Tug and Tow has been assumed to be used for the stretch.

Directional Flow of Traffic

It has been assumed that in 2020 the vessels shall be able to get cargo in both directions for about 25% of the total cargo and in 2025 50% and by 2045 the number shall be about 70%.

Freight rates

The freight rates have been taken averaging the upstream and downstream cargo and the effect of the vessel size on freight rates has been also accounted for. The operational period for the vessels has been assumed to be 250 days in a year.

Year	2015	2020	2025	2035	2045
Vessel Size in MT	1000	2000	2500	3000	
IWT BC	1.83	1.6725	1.475	1.396	1.3565
IWT MAC		1.1025	0.92	0.868	0.816
IWT FAC		1.05	0.868	0.816	0.675

Growth

The growth has been accumulated on cumulative year on year basis.

Table 83: Earliest consideration of NW-1 terminals for forecast calculation (per time block)

NW-1 Terminal	Start
Sagar Island	2015
Haldia MMT	2020
Budge Budge	2035
Kolkata GRT	2020
Tribeni	2020
Katwa	2025
Pakur	2035
Farakka	2025
Raj Mahal	2025
Sahibganj MMT	2020
Manihari	2025
Kahalgaon	2025
Semaria	2025
Patna	2020
Doriganj	2020
Ballia	2025
Ghazipur	2020
Ramnagar MMT	2020
Chunar	2035
Mirzapur	2035
Allahabad	2035
Seq/Other River	2015

Source: PMU / IWAI, March 2016

Finally, inclination to shift to the NW-1 depends on the inauguration date of each multi-modal terminal. Construction of six terminals is envisaged (detailed planning has partly been initiated) with finalization date before the year 2020. In parallel growth to the expected cargo-traffic volumes, other terminals are planned to be constructed between the years 2020 and 2025, with construction of the last terminals upstream of Ramnagar/Varanasi envisaged to be finalized between the years 2025 and 2035. *Table 84* depicts the years for which any multi-modal terminal envisaged to be established alongthe NW-1 can be considered earliest for calculation with the Consultants' Transport Forecasting Model. Through an iteration process, the Consultants calculated all feasible alternatives for a multi-modal terminal, through which cargo could be routed for all O/D pairs for which the optimum terminal would not be finalized before 2020.

10.1.4 Volume forecasts

After the decision whether a transport case could be shifted to IWT, the volumes of 2014 are extrapolated to the forecast years 2020, 2025, 2035 and 2045. The transport model extrapolates the divertible volumes by using assumptions on growth rates collected from relevant market actors (shippers, consignees) in the states of West Bengal, Bihar, Jharkhand and Uttar Pradesh. In addition, and especially in case that there are no statements available from market actors, the model takes macro-economic growth rates as parameters for extrapolation. These general market growth rates are calculated with the methodology of elasticity techniques, using the development pattern of relevant economies per different cargo types (dry bulk, liquid bulk, neo-bulk, general cargo and other cargo types).

Growth Rates:

As market actors can give solid estimations on the development of their transport volumes only for the next 5-10 years, the general market growth rates are used by the model for all mid- and long-term volume forecast from 2020 onwards until 2045. For that time frame, the model is calculating an average weighed growth rate per O/D-pair based on the market actors' growth rate and of the general market growth rates. The following table indicates the weights between growth rates reported by market actors and the general market dynamics. For earlier years, more weight is given to the growth rates specifically reported for an OD-Pair. For later periods, more weight is put on the general market dynamics.

Table 84: Forecast growth rates – Weighting of specific and general market expectations by year

	2015	2016-20	2021-25	2026-35	2036-45
Reported Growth Rate	100%	90%	50%	25%	0%
General Market Growth Rate	0%	10%	50%	75%	100%

Source: Consultants, 2015

The general market growth rates have been based on elasticity analysis of historic production and demand data. Elasticity is a tool for measuring the responsiveness of a function to changes in parameters. For example, to determine the elasticity of the two parameters ‘Traffic Volumes’ and ‘GDP’, the following equation can be applied:

$$Elasticity = \frac{\% \text{ change in sand tonnage}}{\% \text{ change in GDP}}$$

Following this equation, the elasticity is the ratio of the %change in one variable to the %change in the other variable. Thus, if the elasticity is larger than 1, the relationship between the two parameters is considered to be elastic (a parameter responds largely to small changes in other parameters). If it is less than 1, the relationship is said to be inelastic (it does not change much in response to changes in other parameters). In order to forecast growth rates of volumes of different commodities year by year, the current volumes are multiplied by the forecasted % change in GDP or in population and by the ‘multiplier’ which is specific to each commodity type.

Growth rates thus derive from analyzed and assumed elasticities in combination with the forecasts of real GDP and population. GDP is considered the main driver for most commodities; however, population is considered the main driver for agricultural and staple goods.

Table 85: Real GDP and population forecast India (annual %-change)

	2015	2016	2017	2018	2019	2020	2025	2035	2045
GDP	7.46	7.47	7.55	7.65	7.70	7.75	6.61	5.18	4.25
Population	1.24	1.22	1.21	1.19	1.17	1.15	1.02	0.74	0.48

Source: GDP: 2015 IMF data for years until 2020, thereafter 2014 OECD long-term baseline projections from OECD Economic Outlook No. 95. Population forecast based on data from UN ESA 2015.

The following table provides an overview over the derived general market growth rates, based on analysis of historic elasticities and under consideration of GDP and population forecasts. In line with common practice, growth rates have been derived under the general assumption of decreasing elasticities to account for increasing market saturations as well as a structural change of the economy towards services. Thus, the forecast may be seen to have a somewhat conservative edge.

Table 86: General market growth factors for traffic forecast (2015-2045)

Commodity Type	Driver	Average Yearly Traffic Growth Factors			
		2015-2020	2021-2025	2026-2035	2036-2045
Coal	GDP	1.09	1.03	1.02	1.01
	Population	1.03	1.02	1.01	1.01
Fertilizer	Population	1.01	1.01	1.01	1.01
Rice	Population	1.02	1.02	1.01	1.01
Wheat	Population	1.01	1.01	1.01	1.00
Maize	Population	1.02	1.01	1.01	1.01
Other Food Grains	Population	1.02	1.01	1.01	1.01
Corn	Population	1.02	1.01	1.01	1.01
Flour	Population	1.02	1.01	1.01	1.01
Sand	GDP	1.10	1.05	1.03	1.02
Stone Chips	GDP	1.10	1.05	1.03	1.02
Natural Aggregates	GDP	1.10	1.05	1.03	1.02
Lime Stone	GDP	1.10	1.05	1.03	1.02
Concrete	GDP	1.10	1.05	1.03	1.02
Cement	GDP	1.06	1.05	1.03	1.02
Iron Ore	GDP	1.01	1.01	1.01	1.01
Fly Ash	GDP	1.04	1.04	1.03	1.02
Animal Feedstuff	Population	1.02	1.02	1.01	1.01
Plastic Granules	GDP	1.07	1.06	1.04	1.03
LPG Gas	GDP	1.05	1.04	1.03	1.01
Petroleum	GDP	1.05	1.04	1.03	1.01
Edible Oil	Population	1.04	1.02	1.01	1.01
Logs	GDP	1.05	1.04	1.03	1.02
Paper	GDP	1.05	1.04	1.03	1.02
ODC	GDP	1.05	1.04	1.03	1.02
Steel	GDP	1.06	1.04	1.03	1.02
Container	GDP	1.13	1.07	1.04	1.03
Handloom & Agro Equipment	GDP	1.07	1.05	1.04	1.03
	Population	1.03	1.02	1.01	1.01
Vehicles	GDP	1.09	1.08	1.05	1.03

Source: Consultants, 2015

The following paragraphs close with some particular remarks on three relevant commodities: coal, construction materials, and containers.

Coal:

Until 2018 a certain number of coal-heated thermal power plants will start operation along NW-1. To overcome any erratic supplies of indigenous coal, the MOP allows power plants to blend imported coal to the extent of 20%.⁵² Thus, the transport model assumes that approximately 20% of coal requirements of those thermal power plants which are or will be located near to the NW-1 will be satisfied through imported coal which in turn is potential volume for IWT.

Sheet 16 “Coal Projects - Project Region” of Volume II: Transport Forecast Model presents a list of already existing or planned thermal power plants. Subject to their distance from NW-1, the model takes into account the thermal power plants marked in blue. For all these future thermal

⁵² Coal Movement on Ganga (NW-1), IWAI presentation, 25 February 2010, p.18

power plants, specific O/D-pairs have been added to the forecast model in order to account for the associated coal volumes expected on NW-1.

Construction Materials:

With regard to commodities that are closely linked with India’s building industry, such as sand, stone chips, natural aggregates, lime stone or concrete, there will be relatively high annual growth rates in the next five years until 2020 due to the goals laid down in the 11th and 12th Five-Year Plans of the Indian Government. The following figure shows India's last years’ construction spending (in billions US\$ per market year) with a CAGR of 13.4% for residential construction, and CAGR of 12.2% for non-residential constructions.

Figure 55: India’s construction spendings

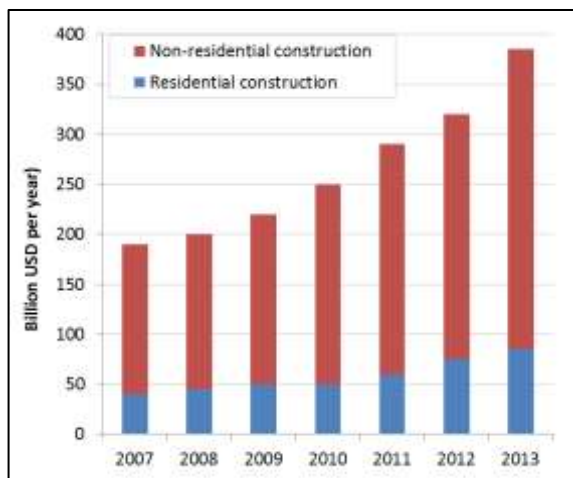

Source: Consultants, 2015 based on data IHS Global Insight (2009) and numbers of 11th Five-Year-Plan

The growth in construction sector in GDP (3.85% in 2010-2011 compared to 2.85% in 2006-07) has primarily been on account of increased spending on physical infrastructure in the last few years through programs such as National Highway Development (NHDP) and PMGSY/Bharat Nirman (*India’s Twelfth Five Year Plan, Chapter 19, p. 362*). The Consultants calculated the annual average growth rate (AAGR) in this sector to be about 8% in the year 2020, decreasing to 2% in 2045.

Containers:

With an AAGR of about 13%, container traffic growth is expected to be relatively high during the initial years, driven by the general economic development as well as increasing containerization. The latter effect is likely to be significant in particular after opening of multimodal terminals along NW-1, which will facilitate the multi-modal transport in the corridor.

It should be noted, however, that the mentioned effects will decrease over time. As a consequence, the Consultants calculated the AAGR to decline to 3% by the year 2045 based on decreasing elasticities.

10.2 Results of traffic forecast for existing and augmented NW-1

Given the freight tariff rates of the competing transport modes roads and railways, and assuming that short-range pre- and onward carriage will not be charged more than 50% higher

than longer range road transport, the Consultants calculated the freight tariff rates for shipping dry bulk, bagged, neo-bulk and general cargo on the NW-1 as indicated in the previous *Chapter 10.1.3*. From IR data sources, the Consultants concluded that terminal handling charges in the railway mode are already included in the published freight tariff rates (explained by a relatively high charge for the shortest segment of 1-125 km distance).

10.2.1 Total cargo volumes by case

Under the above assumptions (see *Chapter 10.1.1* for a description of the below three cases), following cargo traffic volumes (by types) could be projected for the entire waterway.

Table 87: Cargo volumes projected 2020-2045 – by scenario (tons)

Year	Low Augmentation Case	Medium Augmentation Case	Full Augmentation Case
2020	120,14,210	218,88,955	225,22,417
2025	143,64,941	373,27,425	431,49,885
2035	168,59,505	556,27,176	916,10,968
2045	181,42,494	654,54,128	1320,11,894

Source: Consultants’ Market Survey July-October 2015, calculations by transport model

Above table shows that, in the case of sufficient development of the NW-1 (medium augmentation) as planned, more than 65 MMT of cargo could be shifted onto the NW-1 by the year 2045. This accumulated cargo volume is derived from diverted traffic (for details see *Sheet 15: “Traffic Forecast - Freight Rates Comparison including already existing IWT traffic”* of *Volume II: Transport Forecast Model*) out of the almost 520 O/D pairs which were identified as potentially feasible during the Consultants’ market survey.

Figure 56: Cargo volumes projected 2020-2045 – by scenario (tons)

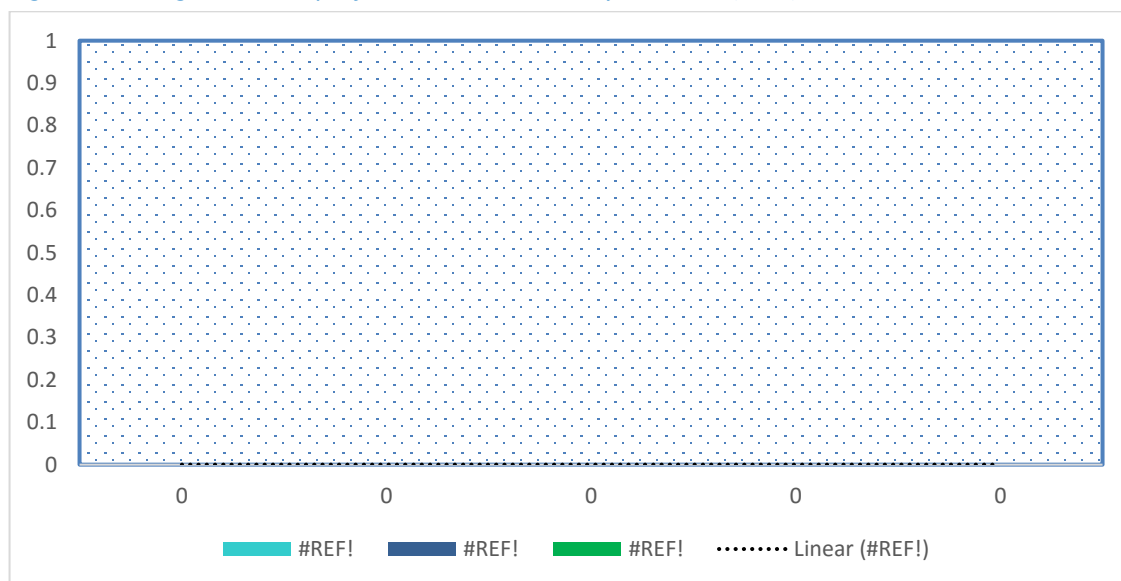

Source: Consultants’ Market Survey July-October 2015, calculations by transport model

The relatively small margin between medium and full augmentation cases is due to the fact that most shipping traffic would be expected in the downstream sectors of the NW-1 (see next section) which will be dredged to 3m depth also under the Medium Augmentation Case.

For the above reason and due to the fact that the Medium Augmentation Case almost perfectly reflects the dredging depths as presently planned by the MoS, the following sections are limited to a discussion of this MAC. Low and full augmentation cases are presented in the data interpretation sheets 3 to 14 of *Volume II: Transport Forecast Model*.

10.2.2 Cargo flows by original transport mode

Apart from slightly more than 5 MMT (mostly coal and fly ash) presently shipped on the NW-1 (and the connected IBPR), more than three fourth of the land-based cargo traffic would be diverted away from roads (see below table). This high proportion is due to the fact that in the Project region much higher cargo volumes are transported by trucks.

Table 88: Cargo flows by original transport mode before deviation (MAC, million tons)

Years	Rail	Road	IWT	Future IWT	Grand Total
2020	0.89	17.20	2.30	1.50	21.89
2025	11.91	21.05	2.87	1.50	37.33
2035	22.29	28.95	2.89	1.50	55.63
2045	22.71	30.88	10.36	1.50	65.45

Source: Consultants' Market Survey July-October 2015, calculations by transport model

Future IWT traffic consists of imported coal to upstream thermal power plants (TPPs), which is expected to be diminished following Gol policy (see *Chapter 5*).

Figure 57: Cargo volumes by original transport mode before deviation (million tons)

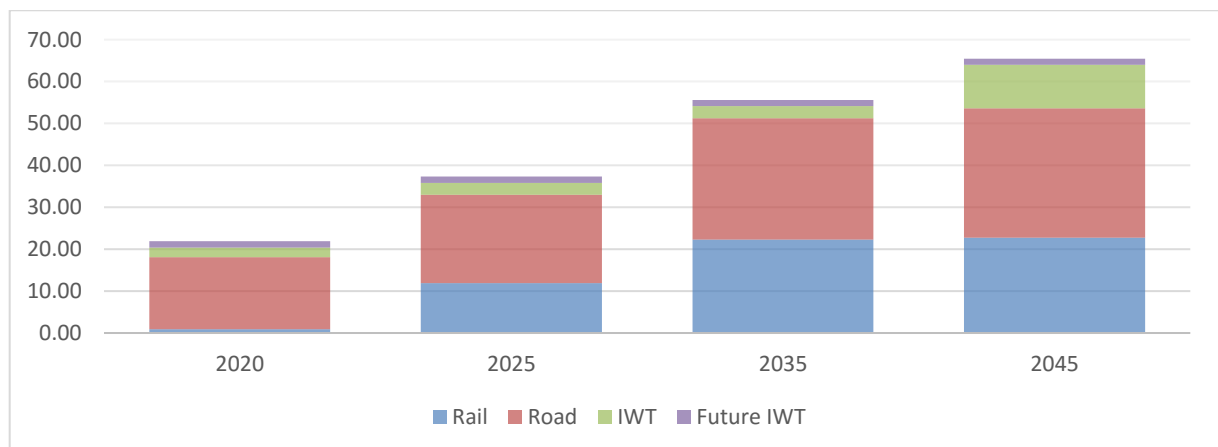

Source: Consultants' Market Survey July-October 2015, calculations by transport model

10.2.3 Cargo volumes upstream against downstream flows

The following section compares the traffic flow development on the NW-1, distinguishing between upstream and downstream shipping.

Of the 2014 cargo volumes shipped on the NW-1, about 70% are being transported upstream. Most of this cargo consists of imported coal being shuttled to the Farakka TPP.

Table 89: Cargo flows upstream vs downstream – development 2020-2045 (MAC, million tons)

Years	Upstream	Downstream	Grand Total
2020	15.37	6.52	21.89
2025	29.78	7.55	37.33
2035	36.69	18.94	55.63
2045	46.22	19.24	65.45

Source: Consultants’ Market Survey July-October 2015, calculations by transport model

By the year 2045, the share of upstream cargo would increase to 70%, much of it originating from shipments of imported coal to the thermal power plants which are being erected mainly in the downstream sectors (Bihar) of the NW-1. Fly ash results from burning the coal at TPPs, thus fly ash equivalent to about one-third of coal volumes constitutes one major commodity for downstream shipment. Furthermore, a combination of overseas and coastal cargo from Haldia and Kolkata would result in increased shipments from the middle stretches of the NW-1 catchment area to the Varanasi-Allahabad region.

Figure 58: Cargo flows upstream vs downstream 2020-2045 (million tons)

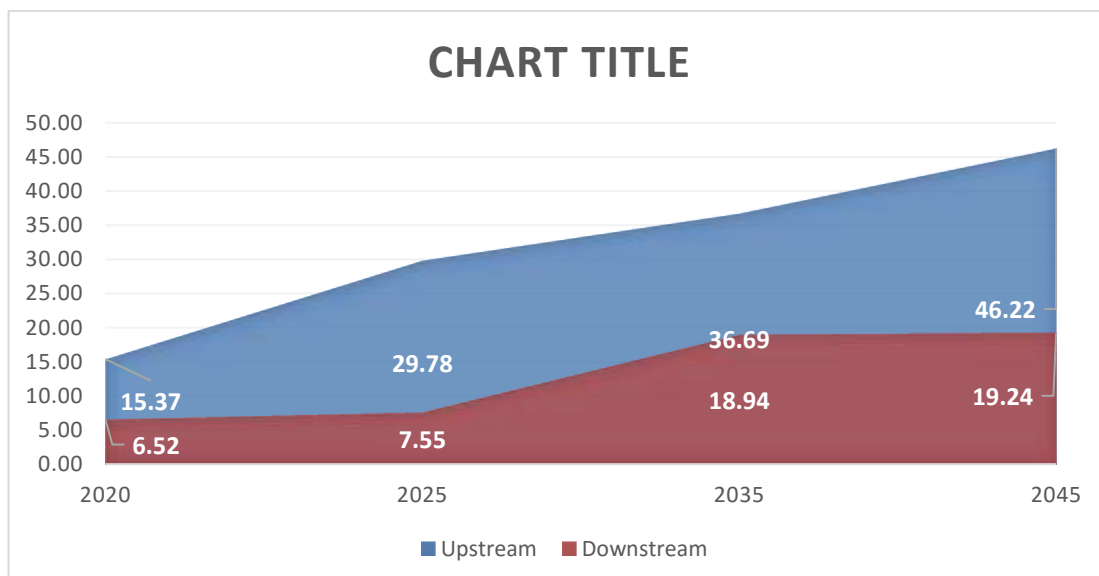

Source: Consultants’ Market Survey July-October 2015, calculations by transport model

Shipments by 2,000-ton barges on the middle stretches of the NW-1 will be made possible through large river-dredging works there, which will facilitate large barge operations on the Ballia-Allahabad sector of the NW-1.

10.2.4 Volumes by cargo types

The following section lays out the development of shipping distinguished by cargo (packaging) types by comparing the cargo flows between beginning (year 2015) and end (year 2045) of the projection period.

As the below table and graphic impressively show, dry-bulk cargo shipments would constitute the major cargo type to be moved on the NW-1. With almost two-third of total volumes, this cargo type holds the highest potential to be diverted onto the NW-1.

Table 90: Cargo volumes by type projected 2015-2045 (MAC, million tons)

Year	2020	2025	2035	2045
Bagged	1.93	2.07	4.12	4.19
Container	4.19	4.53	4.98	5.38
Dry Bulk	11.33	26.05	41.29	50.57
General Cargo	1.62	1.69	1.76	1.77
Liquid Bulk	0.01	0.01	0.01	0.01
Neo-Bulk	2.75	2.93	3.12	3.18
Ro-Ro	0.05	0.05	0.35	0.36
Grand Total	21.89	37.33	55.63	65.45

Source: Consultants' Market Survey July-October 2015, calculations by transport model

Between the year 2025 and 2035, container shipments from Kolkata to both the industrial Varanasi-Allahabad region and for onward trucking into the Katmandu Valley of Nepal would be established on the NW-1. Containerized cargo would reach a significant volume of more than 5 MMT by the year 2045.

Figure 59: Cargo volumes by type projected 2015-2045 (million tons)

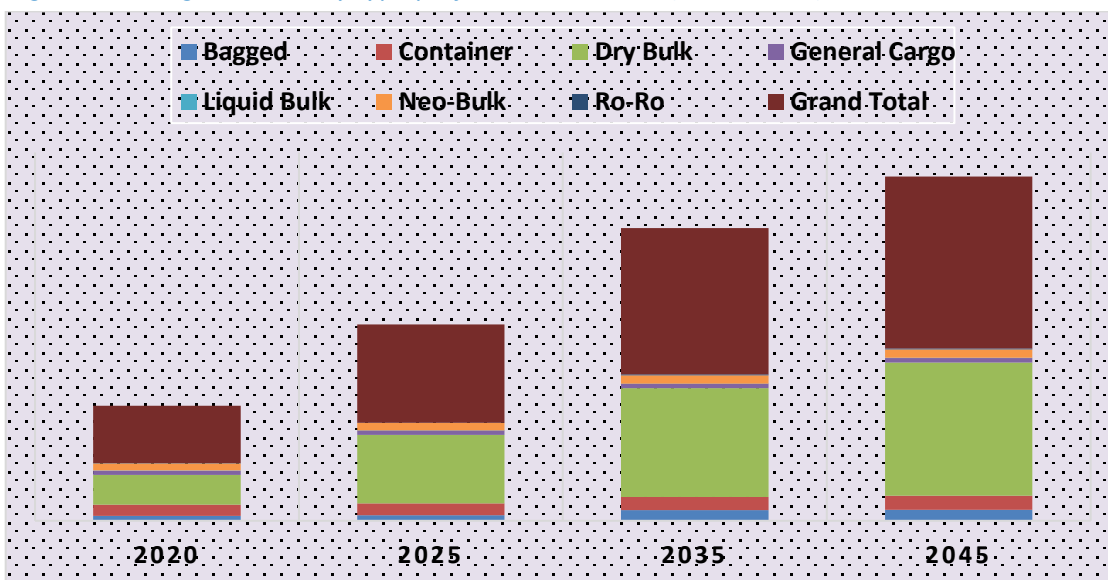

Source: Consultants' Market Survey July-October 2015, calculations by transport model

Bagged cargo flows would reach 4.19 MMT by the year 2045. Finally, flows of neo-bulk shipments consisting mainly of prefabricated steel for housing and plant construction would reach 3.18 MMT.

10.2.5 Cargo volumes by commodity

Shipments of construction materials, particularly natural aggregates (stone chips and bagged cement), would benefit most from waterway improvements. With more than 24 MMT by 2045, this commodity group would constitute by far the largest proportion of projected cargo traffic on the NW-1. With more than 11 MMT, coal would follow suit. Large quantities of fly ash (Minerals & Chemicals) would constitute a significant counter-flow to coal shipments.

Table 91: Cargo volume forecast 2015-2045 by commodity group (MAC, million tons)

Year	Coal	Construction Materials	Consumer Goods	Container	Fertilizer	Food and Foodstuff	Gas and Petroleum	Minerals & Chemicals	Project Cargo	Vehicles	Grand Total
2020	1.92	9.97	0.34	4.19	0.21	2.26	0.84	1.61	0.48	0.05	21.89
2025	8.12	17.97	0.41	4.53	0.22	2.38	0.89	2.26	0.50	0.05	37.33
2035	13.39	29.71	0.42	4.98	0.50	2.46	0.96	2.35	0.51	0.35	55.63
2045	20.98	31.43	0.43	5.38	0.50	2.48	0.97	2.40	0.52	0.36	65.45

Source: Consultants' Market Survey July-October 2015, calculations by transport model

Container would constitute the third most important commodity group with almost 5.38 MMT of containerized cargo by 2045. Foodstuff, mainly bagged grains, with 2.48 MMT would represent another important commodity group.

Figure 60: Cargo volume projection by commodity group 2015-2045 (million tons)

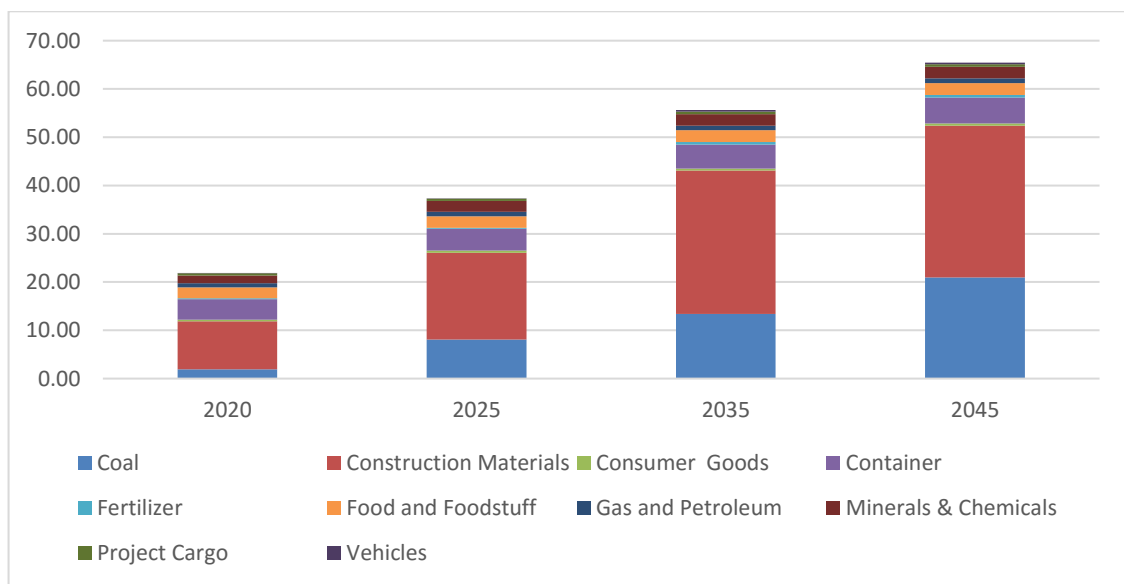

Source: Consultants' Market Survey July-October 2015, calculations by transport model

Gas & petroleum moved in drums (neo-bulk) plus project cargo, generally too heavy and spacious to be trucked per road or transported on rail, with about 1 MMT constitute the last important commodity groups.

Below table and figure detail the overleaf-described split of groups into individual commodities.

Table 92: Cargo volume forecast 2015-2045 by individual commodity (MAC, tons)

Year	Bleaching Powder	Cement	Coal	Container	Fertilizer	Flour	Fly Ash	Food	Food Grains	Iron Ore	Lime Stone	Logs & Wood	LPG Gas
2020	650	1063697	1917071	4191502	213658	30047	1558354	1624342	87208	19830	4169	104069	11095
2025	656	1148182	8123698	4526822	219267	30907	2095654	1689101	91895	124938	4377	108441	11650
2035	663	2851943	13388403	4979504	498621	31483	2095654	1756115	94742	166364	4032827	111844	11999
2045	669	2908982	20975354	5377864	503607	31798	2137567	1773676	95689	168027	4113484	114081	12119

Minerals	Natural Aggregates	Paper	Petroleum	Plastic Granules	Project Cargo	Rice	Sand	Statues	Steel	Textiles	Tobacco	Vehicles	Wheat	Grand Total
24040	7639598	16028	832073	10194	483597	51094	170130	129444	991904	191560	0	51454	472148	21888955
24761	15433856	16919	878156	10805	498203	53605	178637	133327	1096808	259634	20528	54541	492059	37327425
24761	21339920	17522	952224	66093	510729	55023	178637	134661	1191692	271152	16586	345096	502918	55627176
25008	22900159	17872	961746	68075	520944	55573	182210	134661	1215526	279287	16752	355449	507947	65454128

Source: Consultants' Market Survey July-October 2015, calculations by transport model

As a summary of this forgoing section, the Consultants state that in the MAC the commodity mix would attain a mixture rather typical for IWT, with construction materials, coal, minerals & chemicals, containers and bagged food & foodstuff being shipped in highest volumes.

Figure 61: Cargo volume projection by individual commodity 2015-2045 (tons)

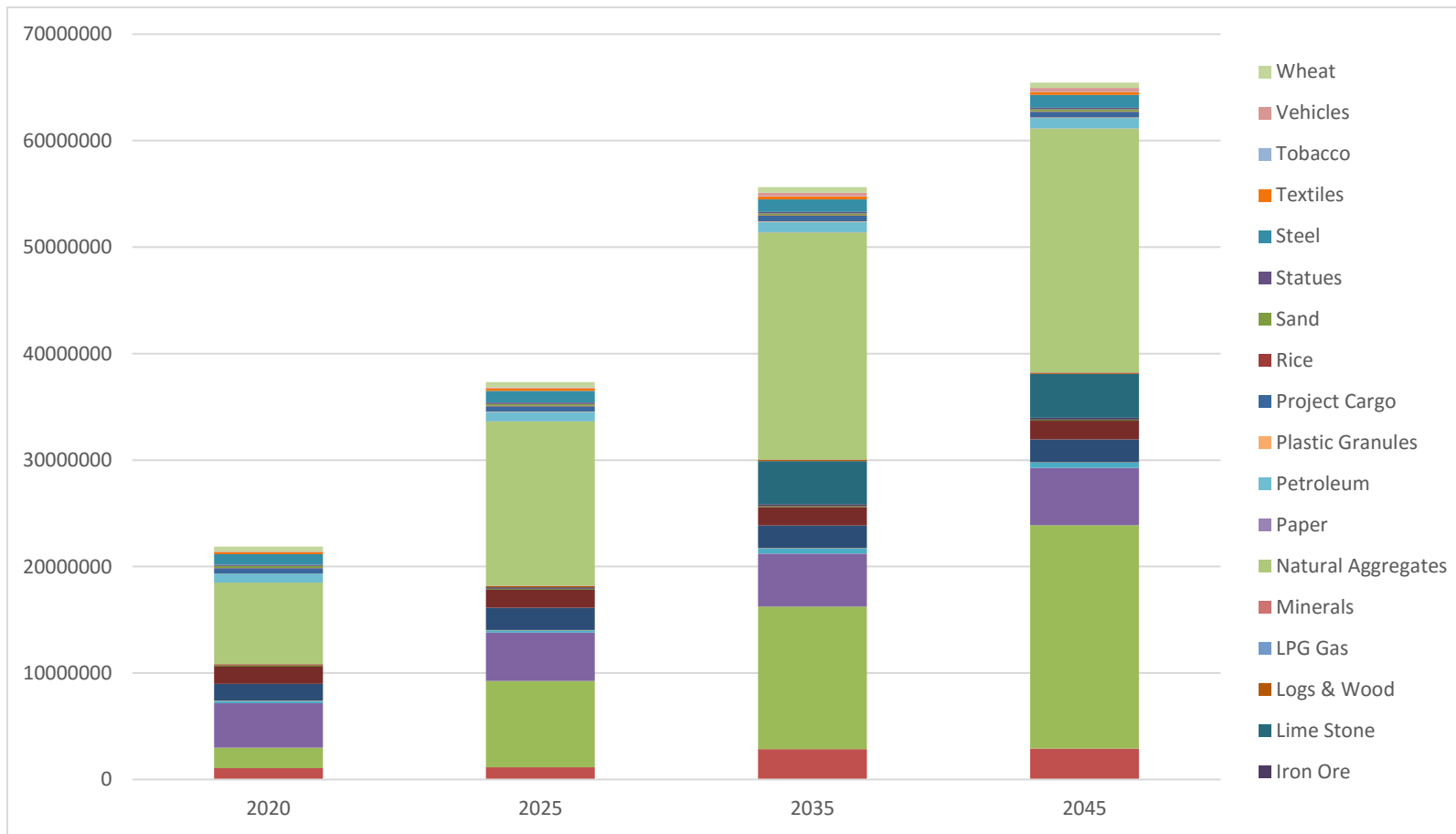

Source: Consultants' Market Survey July-October 2015, calculations by transport model

10.3 Examination of origin-destination pairs

This section finally presents the Consultants’ forecast for the three selected O/D pairs based on the cost advantages of multi-modal against pure land-based transport, as calculated by the transport model and exemplified in *Chapter 6.5.1*.

Overleaf *Table 93* depicts the growth rates which the Consultants calculated for each individual commodity as a trend from historical growth modified by future population and GDP development. Generally, these cargo-traffic growth rates are expected to decline as India’s population growth is diminishing. An O/D pair could be diverted via the NW-1 only as soon as the multi-modal terminals at both ends of the water voyage leg have been established. The Consultants considered this progressive development of multi-modal terminals – according to IWA information – for the year blocks 2020, 2025 and 2035 as depicted in overleaf *Table 93*. In line with the Consultants’ Transport Model, the table indicates the Medium-Augmentation Case (MAC) cargo-traffic forecast in terms of both volumes (tons) and transport productivity (ton-km).

Table 93: Important commodities via NW-1 & respective growth rates

Commodity Type	Earliest Consideration of Terminals (year)	Growth Factor 2016-2020	Growth Factor 2021-2025	Growth Factor 2026-2035	Growth Factor 2036-2045
Coal	2020	1.08	1.06	1.04	1.01
Fly Ash	2015	1.04	1.04	1.03	1.02
Iron Ore	2025	1.09	1.06	1.03	1.01
Lime Stone	2035	1.06	1.05	1.03	1.02
Sand	2025	1.10	1.05	1.03	1.02
Stone Chips	2020	1.10	1.05	1.03	1.02
Plastic Granules	2020	1.05	1.06	1.04	1.03
Grain	2020	1.00	1.01	1.01	1.01
Cement	2020	1.10	1.07	1.05	1.02
Fertilizer	2025	1.03	1.02	1.01	1.01
Steel	2020	1.06	1.04	1.03	1.02
Petroleum	2025	1.09	1.07	1.04	1.01
Logs & Wood	2020	1.10	1.07	1.05	1.02
Textiles	2020	1.03	1.04	1.03	1.03
Project Cargo	2020	1.05	1.04	1.03	1.02
Statues	2020	1.05	1.03	1.01	1.00
Paper	2020	1.05	1.05	1.03	1.02
Food	2020	1.05	1.03	1.02	1.01
Container	2020	1.10	1.08	1.06	1.03
Vehicles	2035	1.05	1.06	1.05	1.03

10.4 IWT-cargo volumes through existing and planned major multi-modal terminals

The following sections depict the forecast traffic flows individually through the existing or planned major multi-modal terminals, viz Haldia, Kolkata, Sahibganj, Patna and Ramnagar/Varanasi.

10.4.1 Haldia Multi-modal Terminal and Sagar Island

Haldia MMT constitutes the largest IWT-infrastructure development downstream of the Farakka Barrage. Under the MAC, total cargo volumes are forecast to reach more than 7.6 MMT by the year 2045 (for details see *Sheet 10: "Cargo-Volume Data Interpretation - Multimodal Cargo Potential Haldia MMT"* of *Volume II: Transport Forecast Model*).

This terminal is dedicated to handle mainly bulk cargoes, much of which would constitute coal loaded for shipment to upstream TPPs which are being erected mainly in Bihar. This coal could alternatively be transhipped midstream off-shore Sagar Island. This major cargo stream is reflected in below *Table 94* which indicates loaded cargo volumes more than double of discharged ones.

Table 94: Haldia MMT - 2020-2045 forecast by loaded versus unloaded cargo (MAC, million tons)

Year	Load	Unload	Total
2020	4.55	3.40	7.95
2025	11.35	4.23	15.59
2035	11.92	4.44	16.36
2045	19.54	4.51	24.04

Source: Consultants' Market Survey July-October 2015, calculations by transport model

Figure 62: Haldia MMT loaded versus unloaded cargo 2020-2045 (million tons)

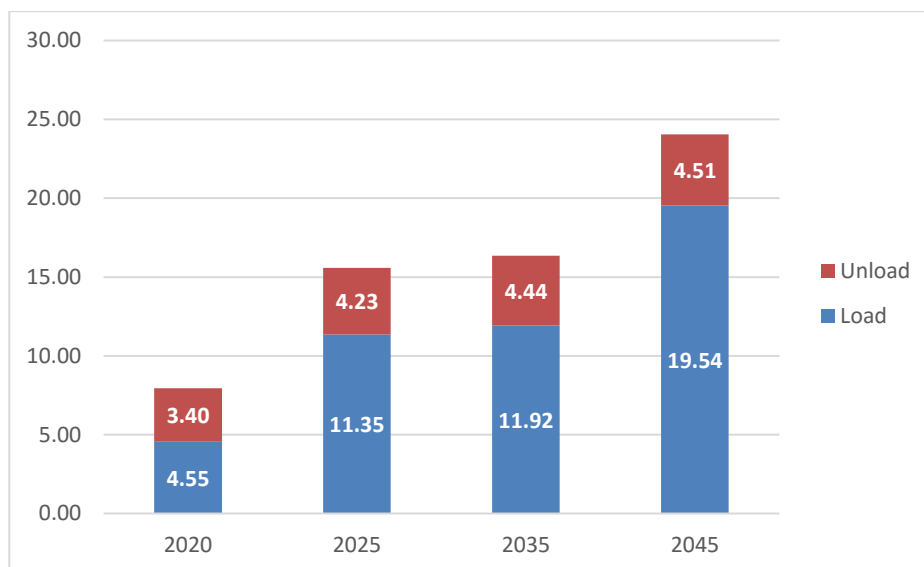

Source: Consultants' Market Survey July-October 2015, calculations by transport model

Table 95: Haldia MMT - 2020-2045 cargo forecast by cargo type (MAC, million tons)

Year	Bagged	Container	Dry Bulk	Neo-Bulk	General Cargo	Total
2020	0.43	0.16	5.15	1.27	0.93	7.95
2025	0.44	0.17	12.61	1.40	0.96	15.59
2035	0.74	0.19	12.89	1.56	0.98	16.36
2045	0.75	0.21	20.51	1.58	0.99	24.04

Source: Consultants' Market Survey July-October 2015, calculations by transport model

By the year 2045, dry-bulk cargo, would be the major cargo. Neo-bulk and general cargo would also constitute important cargo types. In contrast, bagged and containerized cargo volumes would almost be negligible.

Figure 63: Haldia MMT - 2020-2045 cargo forecast by cargo type (million tons)

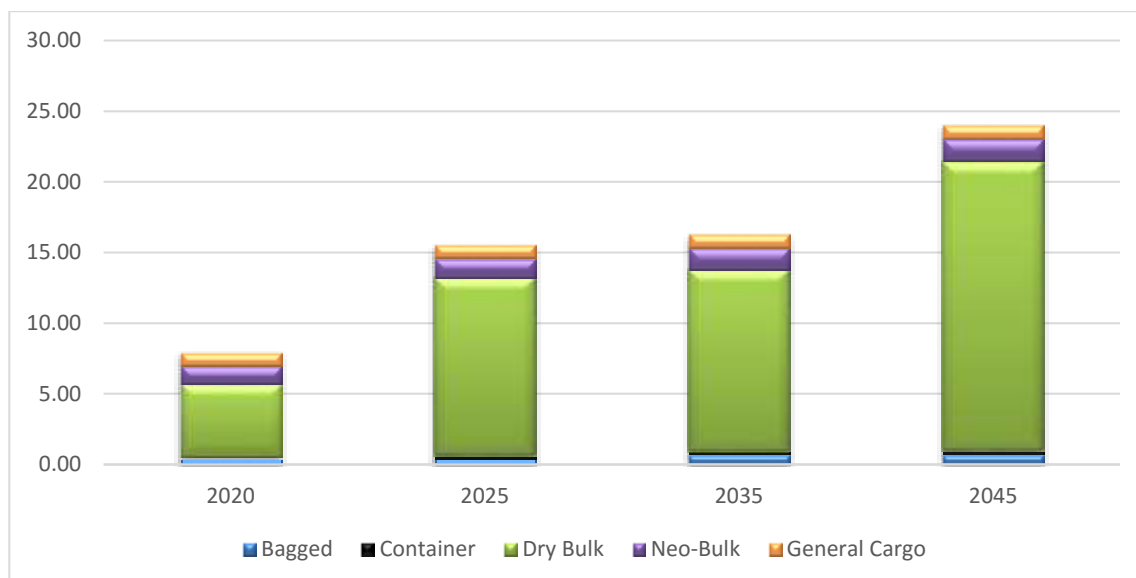

Source: Consultants' Market Survey July-October 2015, calculations by transport model

Coal, gas & petroleum, foodstuff (mostly bagged grain) and minerals & chemicals would constitute the most important commodity groups.

Table 96: Haldia MMT - 2020-2045 cargo forecast by commodity groups (MAC, million tons)

Year	Coal	Construction Materials	Consumer Goods	Container	Fertilizer	Gas and Petroleum	Minerals & Chemicals	Project Cargo	Food and Foodstuff	Total
2020	1.82	0.31	0.12	0.16	0.35	1.00	3.14	0.05	1.02	7.95
2025	8.02	0.38	0.18	0.17	0.36	1.06	4.32	0.05	1.05	15.59
2035	8.26	0.45	0.19	0.19	0.60	1.14	4.41	0.05	1.07	16.36
2045	15.79	0.46	0.20	0.21	0.61	1.15	4.50	0.05	1.08	24.04

Source: Consultants' Market Survey July-October 2015, calculations by transport model

Figure 64: Haldia MMT - 2020-2045 cargo forecast by commodity group (million tons)

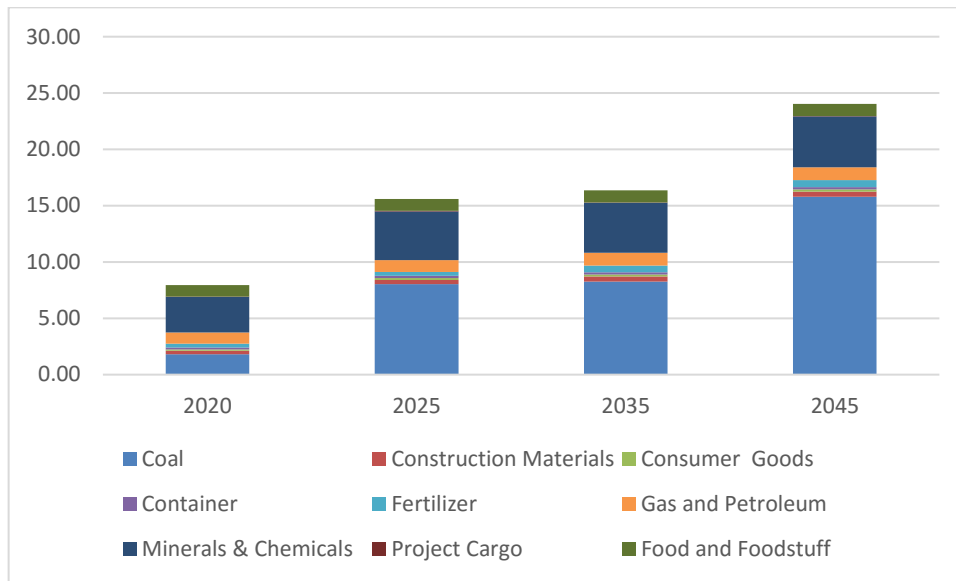

Source: Consultants' Market Survey July-October 2015, calculations by transport model

The GoI might need to decide whether operation of other dry bulk cargoes could be diverted to Haldia MMT away from Kolkata GRT, as demand at the latter terminal (see next section) might outrun the supply of facilities.

10.4.2 Kolkata Garden Reach Terminal

Kolkata GRT will be integrated into the large production and demand generated within the Kolkata metropolitan area. Despite the terminal’s location in a central area (usually with rather balanced demand and supply), the Consultants expect differences in loaded versus unloaded cargo volumes to be very unbalanced. The Consultants expect traffic volumes to increase more than tenfold during the forecast period 2020-2045, of which more than threefourth would be cargo loaded for upstream shipments.

Table 97: Kolkata GRT - 2020-2045 forecast by loaded versus unloaded cargo (MAC, million tons)

Year	Load	Unload	Total
2020	5.01	2.21	7.21
2025	5.36	2.32	7.69
2035	5.89	12.04	17.92
2045	6.29	12.22	18.51

Source: Consultants’ Market Survey July-October 2015, calculations by transport model

Figure 65: Kolkata GRT loaded vs unloaded cargo 2020-2045 (million tons)

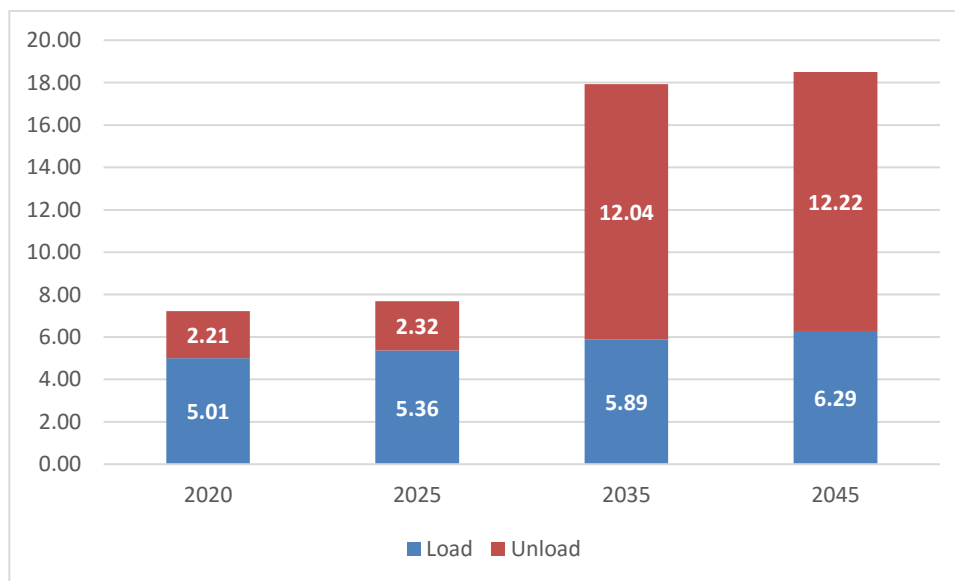

Source: Consultants’ Market Survey July-October 2015, calculations by transport model

One major reason for this unbalance would be the terminal’s dedication to handling mainly general cargoes, most of which would be containerized bound for Nepal and upstream NW-1 (for details see *Sheet 11: “Cargo-Volume Data Interpretation - Multi-modal Cargo Potential Kolkata GRT”* of *Volume II: Transport Forecast Model*). Kolkata GRT could thus develop into an important supply base for the upstream waterway region.

Table 98: Kolkata GRT - 2020-2045 cargo forecast by cargo type (MAC, million tons)

Year	Bagged	Container	Dry Bulk	General Cargo	Liquid Bulk	Neo-Bulk	Ro-Ro	Total
2020	0.39	4.03	0.30	0.30	0.01	2.13	0.05	7.21
2025	0.43	4.35	0.31	0.32	0.01	2.21	0.05	7.69
2035	0.70	4.79	9.48	0.33	0.01	2.27	0.35	17.92
2045	0.71	5.17	9.61	0.33	0.01	2.31	0.36	18.51

Source: Consultants' Market Survey July-October 2015, calculations by transport model

Figure 66: Kolkata GRT - 2020-2045 cargo forecast by cargo type (million tons)

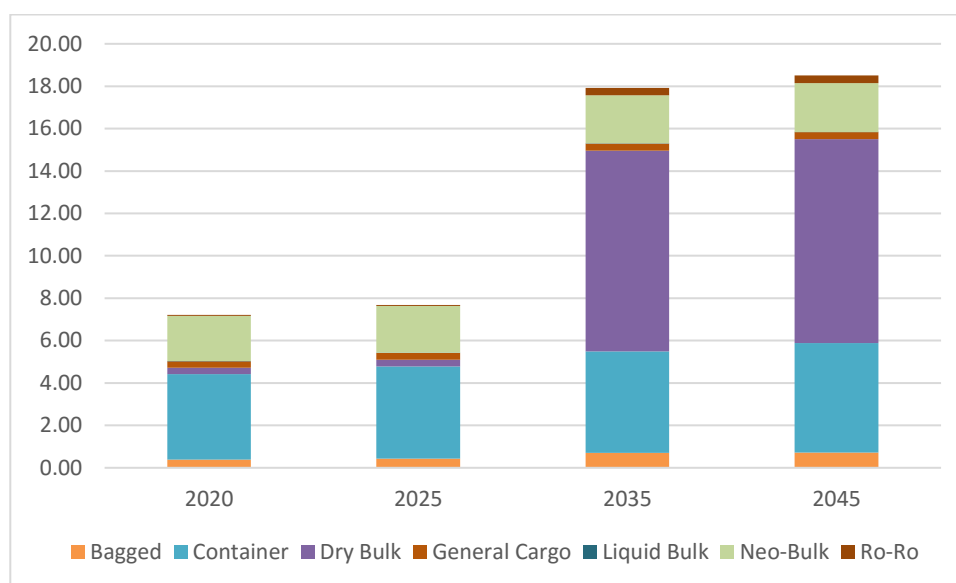

Source: Consultants' Market Survey July-October 2015, calculations by transport model

By far the major commodity would be containerized cargo, followed by construction materials (mainly stone chips and bagged cement) discharged to cater for construction activities in the city, and by minerals & chemicals presently loaded at Howrah Goods Yard on the western Hooghly side opposite of Kolkata city.

Table 99: Kolkata GRT - 2020-2045 cargo forecast by commodity groups (MAC, million tons)

Year	Coal	Construction Materials	Consumer Goods	Container	Fertilizer	Food and Foodstuff	Gas and Petroleum	Minerals & Chemicals	Project Cargo	Vehicles	Total
2020	0.10	1.36	0.16	4.03	0.00	0.59	0.42	0.03	0.48	0.05	7.21
2025	0.10	1.42	0.16	4.35	0.00	0.63	0.43	0.04	0.49	0.05	7.69
2035	5.18	5.76	0.17	4.79	0.00	0.64	0.45	0.10	0.50	0.35	17.92
2045	5.23	5.87	0.17	5.17	0.00	0.65	0.45	0.10	0.51	0.36	18.51

Source: Consultants' Market Survey July-October 2015, calculations by transport model

Container shipments to the industrial Varanasi-Allahabad region and for onward trucking into the Katmandu Valley of Nepal would constitute a large proportion of the containerized cargo.

Figure 67: Kolkata GRT - 2020-2045 cargo forecast by commodity group (million tons)

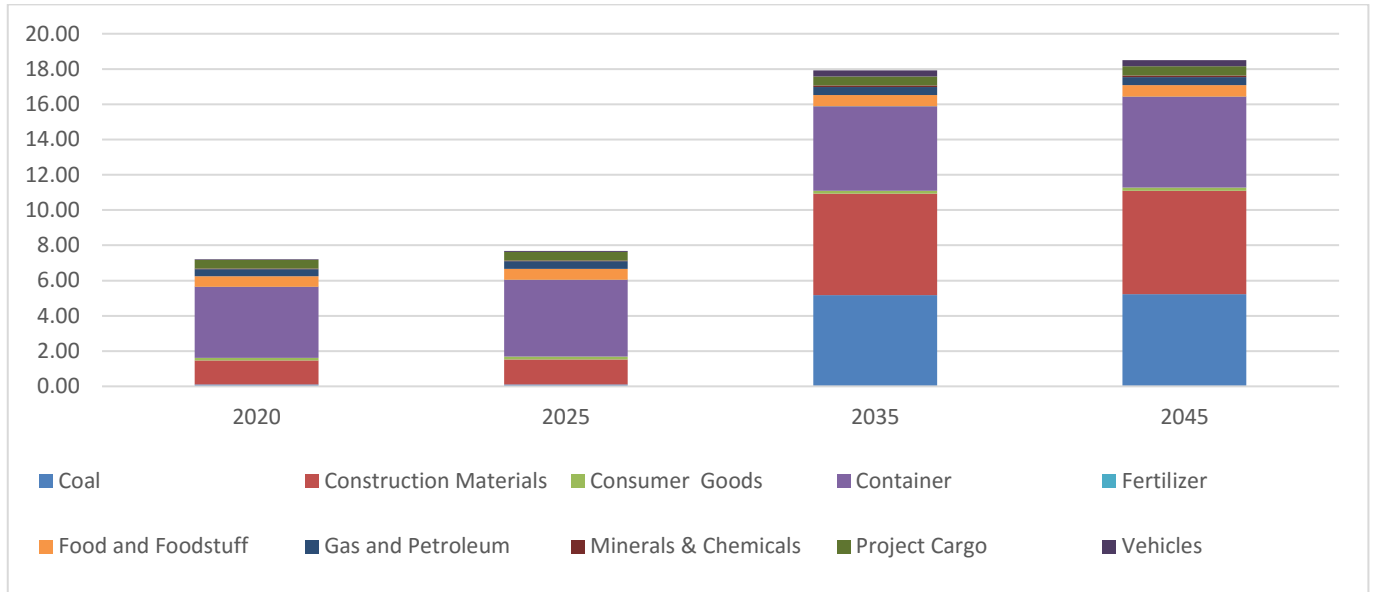

Source: Consultants' Market Survey July-October 2015, calculations by transport model

10.4.3 Sahibganj Multi-modal Terminal

Sahibganj MMT would develop as a terminal entirely dedicated to shipping bulk cargo (stone chips & aggregates, limited amounts of coal) upstream to the urban areas with high demand for construction materials, i.e. Varanasi and Patna (for details see *Sheet 12: “Cargo-Volume Data Interpretation - Multi-modal Cargo Potential Sahibganj MMT”* of *Volume II: Transport Forecast Model*). The Consultants forecast total cargo volumes to reach almost 43.5 MMT by the year 2045, of which more than 65% would be loading operations.

Table 100: Sahibganj MMT - 2020-2045 forecast by loaded versus unloaded cargo (MAC, million tons)

Year	Load	Unload	Total
2020	8.08	1.85	9.92
2025	16.13	7.26	23.39
2035	27.07	7.31	34.38
2045	28.69	14.78	43.47

Source: Consultants’ Market Survey July-October 2015, calculations by transport model

Much of the demand for construction materials downstream of the Farakka Barrage (see *Chapter 10.2.5*) is expected to be shipped through Pakur, Farakka and other small terminals (see next chapter).

Figure 68: Sahibganj MMT loaded versus unloaded cargo 2020-2045 (million tons)

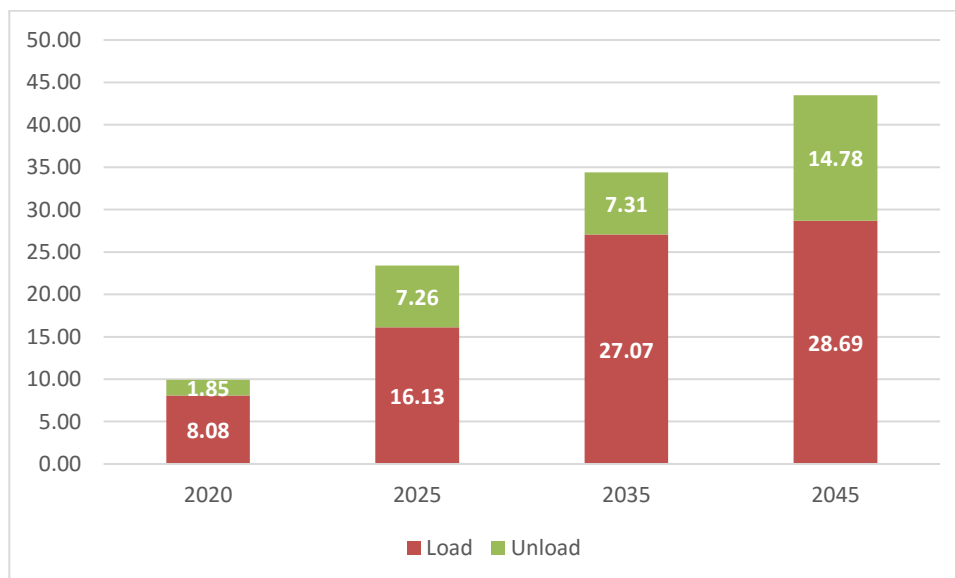

Source: Consultants’ Market Survey July-October 2015, calculations by transport model

Sahibganj MMT would attain a central position as bulk-cargo loading center at the middle NW-1, with the major commodity group being construction materials (mainly stone chips & aggregates).

Table 101: Sahibganj MMT - 2020-2045 cargo forecast by commodity groups (MAC, million tons)

Year	Coal	Construction Materials	Consumer Goods	Food and Foodstuff	Minerals & Chemicals	Fertilizer	Total
2020	1.76	7.80	0.01	0.27	0.00	0.08	9.92
2025	7.28	15.61	0.01	0.30	0.10	0.08	23.39
2035	12.34	21.51	0.01	0.31	0.08	0.12	34.38
2045	19.86	23.08	0.01	0.32	0.08	0.12	43.47

Source: Consultants' Market Survey July-October 2015, calculations by transport model

Figure 69: Sahibganj MMT - 2020-2045 cargo forecast by cargo type (million tons)

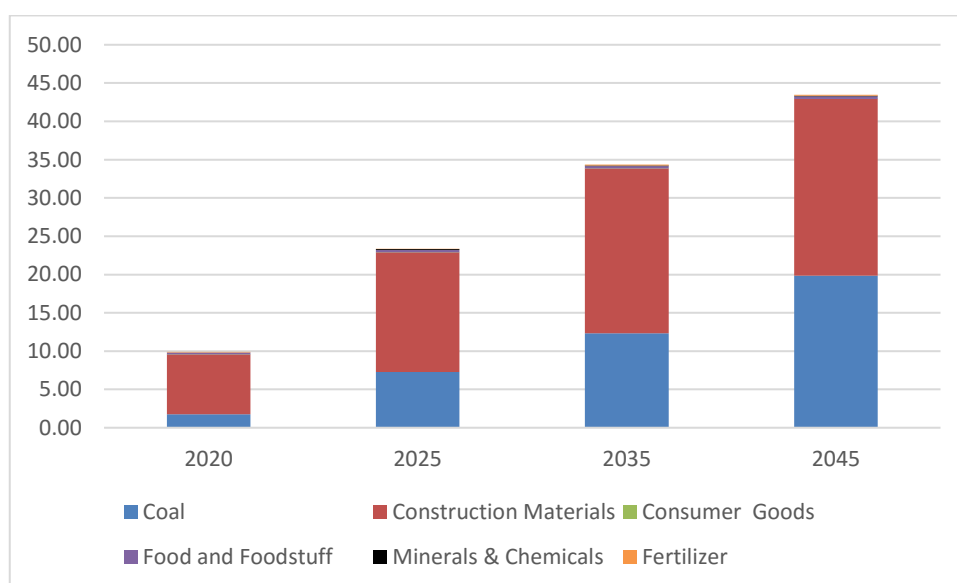

Source: Consultants' Market Survey July-October 2015, calculations by transport model

10.4.4 Patna Terminal

Patna already holds a double-berth adjacent to the NH19 road-bridge crossing the Ganges River. However, cargo operations had, in the past, so far not taken off. With sufficient improvements to the LAD as planned by the GoI and anticipated in the MAC, cargo shipments would take off after the year 2018 (for details see *Sheet 13: "Cargo-Volume Data Interpretation - Multi-modal Cargo Potential Patna MMT"* of *Volume II: Transport Forecast Model*). Until the year 2045, cargo volumes would increase to more than 22 MMT, of which more than 90% would be unloaded at the terminal for onward distribution by truck and rail.

Table 102: Patna - 2020-2045 forecast by loaded versus unloaded cargo (MAC, million tons)

Year	Load	Unload	Total
2020	0.91	6.67	7.58
2025	0.96	12.54	13.50
2035	1.03	19.86	20.89
2045	1.05	21.43	22.48

Source: Consultants' Market Survey July-October 2015, calculations by transport model

In contrast to the major downstream multi-modal terminal at Kolkata, Patna MMT would mainly serve as an important distribution center, where large amounts of dry-bulk, bagged, neo-bulk and general cargo cargo would be unloaded for onward transport, much of it trucked northward into Nepal.

Figure 70: Patna Terminal loaded versus unloaded cargo 2020-2045 (million tons)

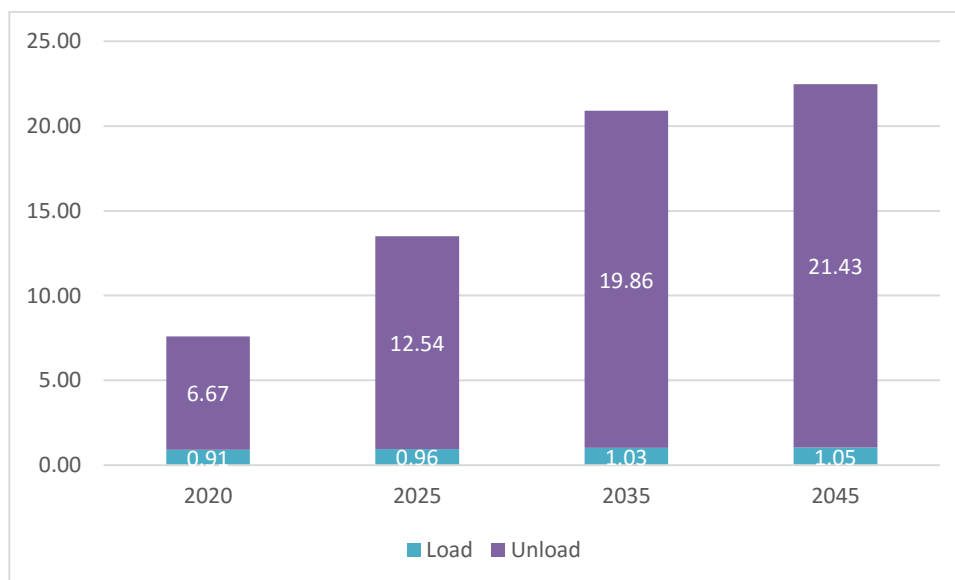

Source: Consultants' Market Survey July-October 2015, calculations by transport model

Table 103: Patna Terminal - 2020-2045 cargo forecast by cargo type (MAC, million tons)

Year	Bagged	Dry Bulk	Neo-Bulk	General Cargo	Total
2020	1.15	5.18	0.96	0.30	7.58
2025	1.24	10.94	1.00	0.32	13.50
2035	2.91	16.51	1.14	0.33	20.89
2045	2.97	18.01	1.16	0.33	22.48

Source: Consultants' Market Survey July-October 2015, calculations by transport model

Figure 71: Patna Terminal - 2020-2045 cargo forecast by cargo type (million tons)

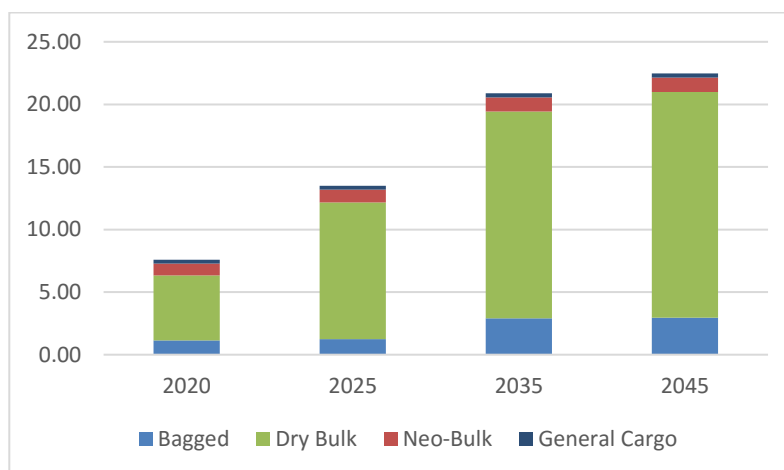

Source: Consultants' Market Survey July-October 2015, calculations by transport model

Most (more than 90% of total) of the unloaded cargo would consist of construction material (stone chips and cement) to cover the demand both with the fast growing city of Patna and the metropolitan areas of Varanasi and Allahabad.

Table 104: Patna Terminal - 2020-2045 cargo forecast by commodity groups (MAC, million tons)

Year	Coal	Construction Materials	Consumer Goods	Gas and Petroleum	Minerals & Chemicals	Project Cargo	Fertilizer	Food and Foodstuff	Total
2020	0.05	6.50	0.07	0.26	0.02	0.21	0.00	0.49	7.58
2025	0.73	11.68	0.07	0.27	0.02	0.22	0.00	0.51	13.50
2035	0.82	18.67	0.07	0.33	0.02	0.22	0.24	0.53	20.89
2045	0.88	20.17	0.07	0.33	0.02	0.23	0.24	0.54	22.48

Source: Consultants' Market Survey July-October 2015, calculations by transport model

Figure 72: Patna Terminal - 2020-2045 cargo forecast by commodity group (million tons)

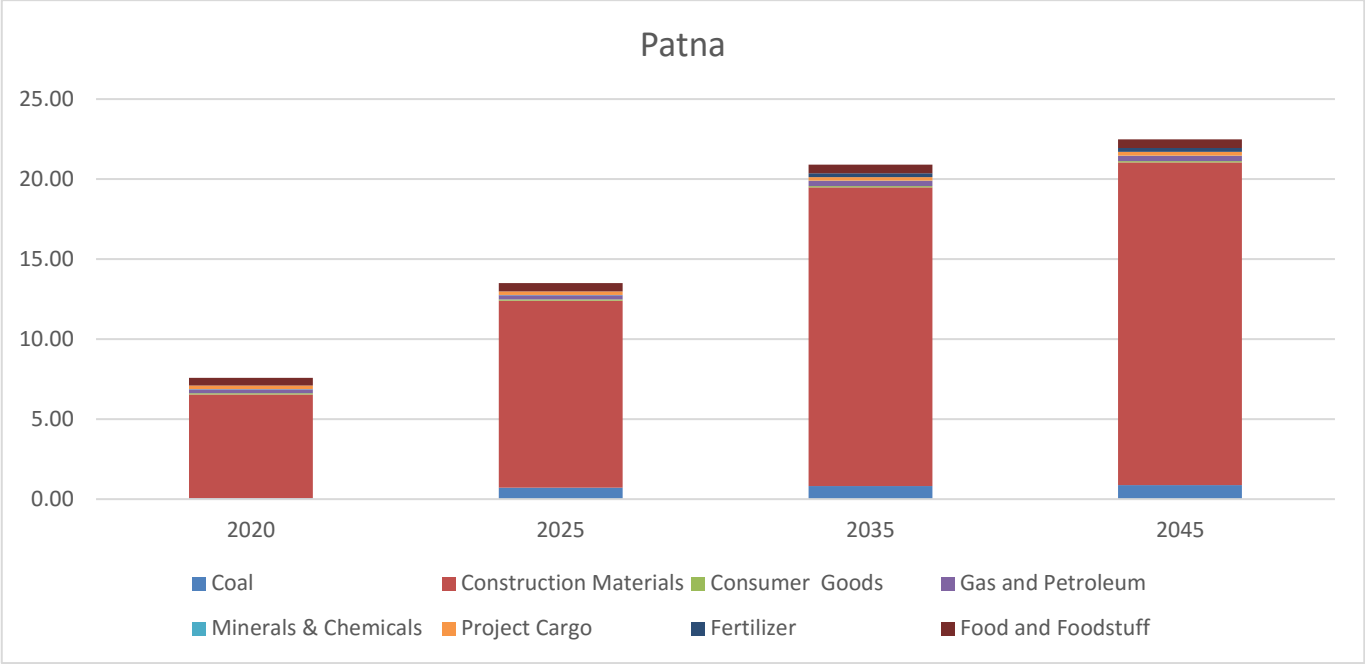

Source: Consultants' Market Survey July-October 2015, calculations by transport model

10.4.5 Ramnagar Multi-modal Terminal

Under the present least-available depth (LAD) limitations, the Consultants expect no IWT-related operations to take place at the Ramnagar MMT. However, with sufficient improvements to the LAD as planned by the GoI and anticipated in the MAC, Ramnagar MMT would be connected by barge operations to the Sector 4 (Ballia-Varanasi) of the NW-1. As Varanasi constitutes an important transportation hub on the Delhi–Kolkata axis – with a fibrant connection to both NH2 and the EDFC – significant consolidation and distribution operations via the NW-1 could now be exercised within the terminal. Cargo traffic in this section of the NW-1 would shoot up to 10.32 MMT, through Ramnagar MMT, in the year 2045 (for details see *Sheet 14: “Cargo-Volume Data Interpretation - Multi-modal Cargo Potential Ramnagar MMT” of Volume II: Transport Forecast Model*).

As below *Table 105* indicates, future cargo traffic volumes would be rather balanced as Varanasi constitutes both an important production center as well as a central distribution point.

Table 105: Ramnagar MMT - 2020-2045 forecast by loaded versus unloaded cargo (MAC, million tons)

Year	Load	Unload	Total
2020	2.20	1.35	3.55
2025	2.35	1.47	3.82
2035	8.51	1.61	10.12
2045	8.67	1.66	10.32

Source: Consultants’ Market Survey July-October 2015, calculations by transport model

Figure 73: Ramnagar MMT loaded versus unloaded cargo 2020-2045 (million tons)

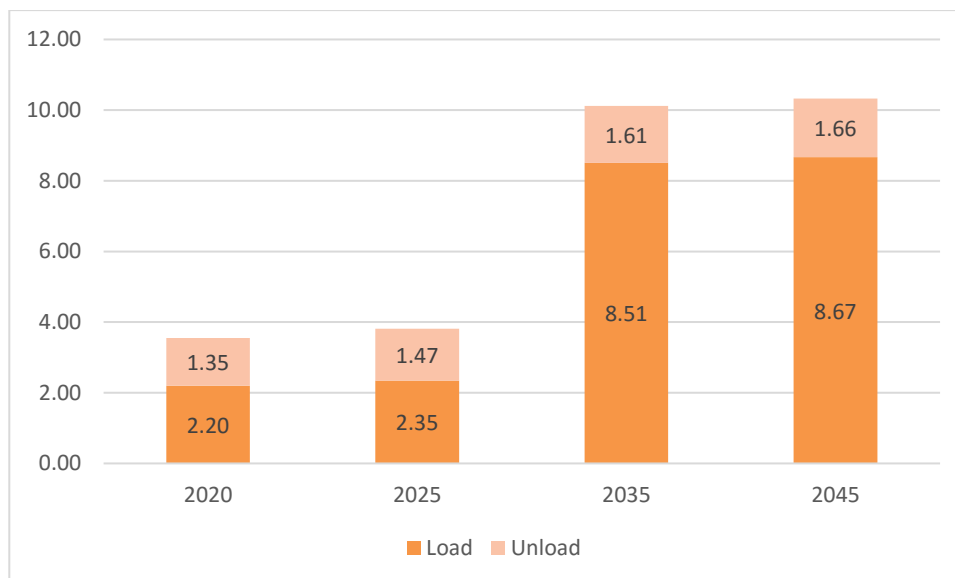

Source: Consultants’ Market Survey July-October 2015, calculations by transport model

These consolidation and distribution operations between trucks and railway could be exercised as DFCCIL is expected to operate a terminal within Ramnagar MMT.

Table 106: Ramnagar MMT - 2020-2045 cargo forecast by cargo type (MAC, million tons)

Year	Bagged	Container	Dry Bulk	General Cargo	Neo-Bulk	Ro-Ro	Liquid Bulk	Total
2020	1.40	0.16	0.14	0.66	1.13	0.05	0.01	3.55
2025	1.50	0.17	0.15	0.69	1.23	0.05	0.01	3.82
2035	3.31	0.19	4.25	0.74	1.27	0.35	0.01	10.12
2045	3.37	0.21	4.34	0.75	1.29	0.36	0.01	10.32

Source: Consultants' Market Survey July-October 2015, calculations by transport model

With sufficient LAD improvements upstream of Varanasi, the Consultants would expect vehicles from the Delhi area to be loaded onto barges for downstream shipment at Allahabad.

Figure 74: Ramnagar MMT - 2020-2045 cargo forecast by cargo type (million tons)

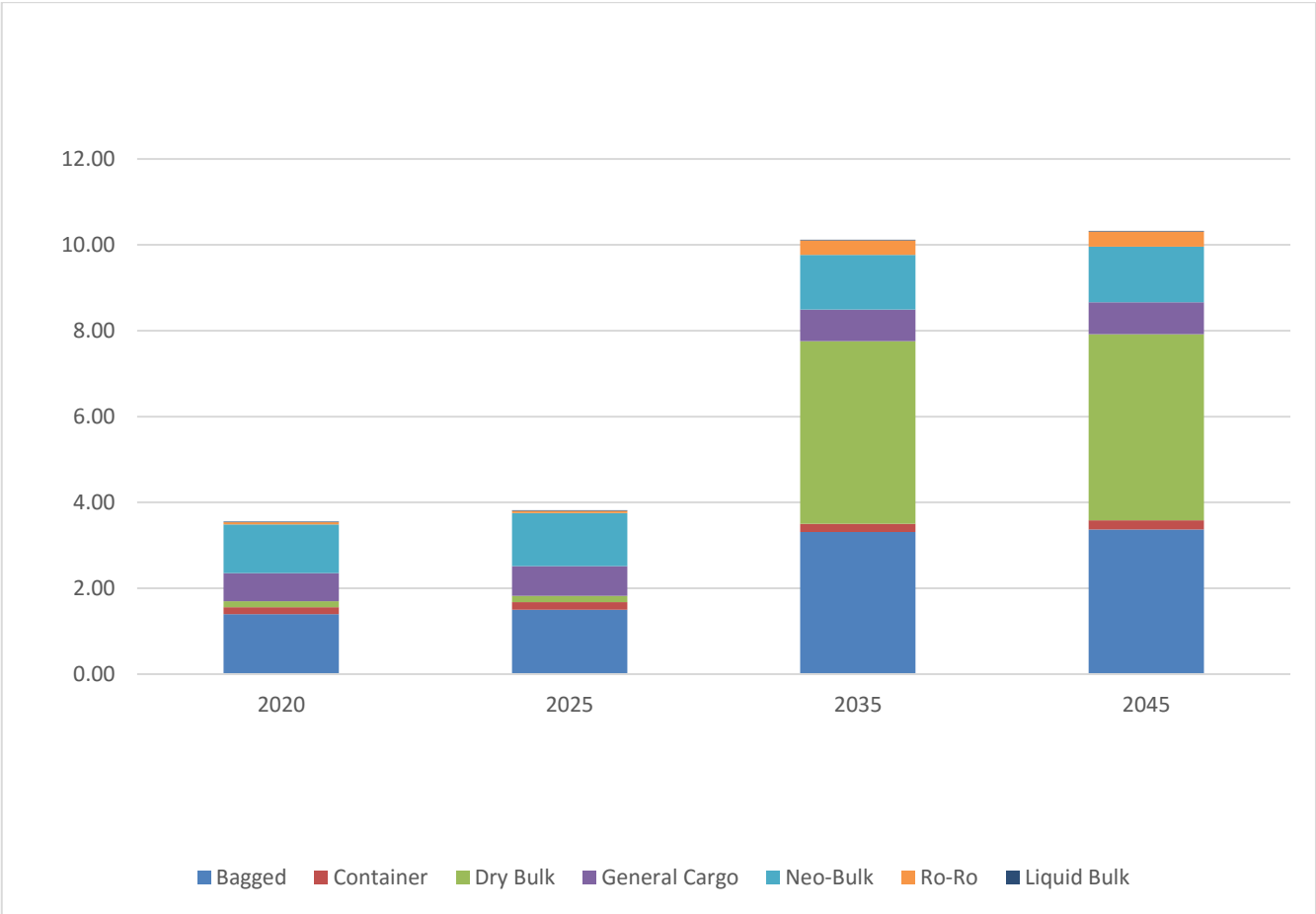

Source: Consultants' Market Survey July-October 2015, calculations by transport model

Table 107: Ramnagar MMT - 2020-2045 cargo forecast by commodity groups (MAC, million tons)

Year	Coal	Construction Materials	Consumer Goods	Container	Fertilizer	Food and Foodstuff	Minerals & Chemicals	Project Cargo	Vehicles	Gas and Petroleum	Total
2020	0.11	1.64	0.33	0.16	0.00	0.98	0.03	0.24	0.05	0.01	3.55
2025	0.11	1.75	0.40	0.17	0.00	1.04	0.04	0.24	0.05	0.01	3.82
2035	0.19	7.50	0.41	0.19	0.04	1.09	0.09	0.25	0.35	0.01	10.12
2045	0.19	7.65	0.42	0.21	0.04	1.10	0.09	0.25	0.36	0.01	10.32

Source: Consultants' Market Survey July-October 2015, calculations by transport model

Figure 75: Ramnagar MMT - 2020-2045 cargo forecast by commodity group (million tons)

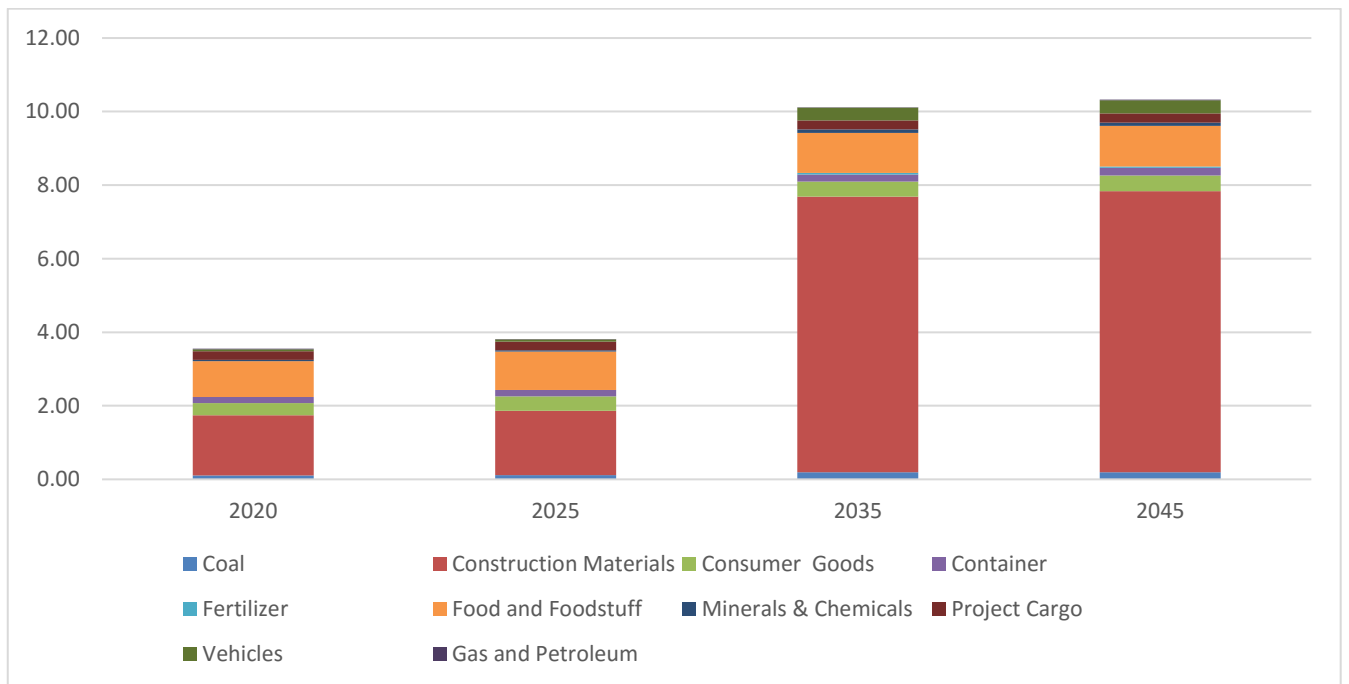

Source: Consultants' Market Survey July-October 2015, calculations by transport model

10.4.6 Ghazipur Multi-modal Terminal

The preferred location for a potential multi-modal terminal at Ghazipur is on the southern side of the Ganges River, thus opposite the city, as shown by the below imagery.

Figure 76: Preferred location for potential multi-modal terminal at Ghazipur, U.P.



Source: Google Earth; information from PMU/IWAI

However, this location would necessitate a pre- or onward carriage by truck via the NH97 river bridge, an estimated road distance of 7 km.

Figure 77: Possible location for a multi-modal terminal in Ghazipur, U.P.



Source: Google Earth; Consultants' investigation

A calculation of potential O/D pairs through the Consultants' Transport Model had identified a potential of 85,000 metric tons cargo for a multi-modal terminal (MMT) at Ghazipur. This is exemplified in *Annex 8*.

The Transport Model calculated only one O/D pair of cargo that could potentially be shipped via the NW-1. This O/D pair represents imported thermal coal to be used by the Buxar thermal power plant. However, as Government policy foresees coal imports to be phased out, the Consultants agreed with IWAI to reduce coal volumes by 4% per year the entire forecast period.

Local Cargo

The cargo volumes as included into the transport model are the ones that had been identified during the Consultants' market survey of August-October 2015. The map in *Figure 77* overleaf depicts the location of interviews held by their market surveyors. Although these market surveyors had spent significant efforts in particularly screening the region close to the NW-1, they had not identified any significant potential cargo at, or in the vicinity of, Ghazipur. Therefore, the surveyors could not hold any interviews with stakeholders in or around Ghazipur. Consequently, the Consultants cannot see a demand for a MMT to operate local products.

Figure 78: Location of one or more interviews with producing units in the Allahabad-Munger sector (red dots)



Source: Consultants' market survey August-October 2016

Regional Cargo

As to regional cargo, the overleaf table depicts the number of daily truck movements into and out of the city of Ghazipur. Two of the origins/destinations (Mau, Azamgarh) are located far away from the NW-1. The other origins/destinations (Varanasi, Buxar, Zamania) are located on the NW-1. However, the preferred location for a potential multi-modal terminal at Ghazipur is on the southern side of the Ganges River, thus opposite the city.

This location would necessitate a pre- or onward carriage by truck via the NH97 river bridge, an estimated road distance of 7 km. The Consultants estimated the road distance from Ramnagar MMT to Varanasi at 10 km, from Gola Ghat to Buxar as 0 km, and from Zamania to any possible future terminal site (still to be acquired) within the city also as 0 km.

In case of dry-bulk cargo (sand, stone chips and soil representing just over 15% of total truck loads) between Ghazipur and Varanasi, the Consultants' transport model calculated the threshold to make shipping by barge profitable at a trucking price well over Rs 5 / ton-km, a freight rate their market surveyors have been rarely told of across the entire survey area. The same holds true for the origins/destinations of Buxar and Zamania, where a trucking price of close to Rs 5 / ton-km would constitute the threshold. Other cargo types (bagged, neo-bulk, general cargo) could not compete at all against door-to-door trucking, as terminal handling costs would be higher compared to dry-bulk cargo movements. Assuming such high trucking prices were charged (and the truckers would not react through price dumping), shortdistance shipping of dry-bulk cargoes (sand, stone chips and soil) could be financially feasible.

There exists a possibility of additional 130 cargo trucks/day carrying clothes, food grain and cement from Varanasi/ Mirzapur through Ghazipur, and onwards from Ghazipur to Nepal (at the time of survey no cargo movement was recorded due to unrest at the Nepal border). Out of this number, about 40-45 trucks could move on the NW-1 from Varanasi via Ghazipur to Nepal. Moreover, there is a local movement of about 10 trucks/day of vegetables and agriculture produce from Ghazipur to Varanasi. Finally, there is also potential of about 40,000 tons/annum of jute products from Kolkata for Ghazipur.⁵³

The calculated total cargo, under the assumptions as noted below the overleaf table, would then amount to just below 2 MMT per year.

⁵³ Information from PMU/IWAI provided 19 February 2016

Table 108: Detail of Trucks/Cargo at Ghazipur Route (number of trucks per 24-hour day)

Route	Total annual Load (tons)	Full Trucks (no.)	Medicine	Grains	Straw	Sand	Stone Chips	Cement	Iron Rod	Electronic Items	Plastic Item	Cloth	Jute	Soil	Fuel	Tiles	Others	Empty	Road Distance (km)
Buxar-Ghazipur	427,200	89	-	3	2	59	9	3	1	-	3	-	-	4	2	1	2	8	54 - 60
Ghazipur-Buxar	259,200	54	5	12	6	2	3	2	-	-	4	-	-	4	6	2	8	63	
Ghazipur-Zamania	288,000	60	4	10	5	8	5	5	-	-	5	-	-	6	3	2	7	67	26 - 34
Zamania-Ghazipur	456,000	95	-	12	8	43	4	5	-	-	5	-	-	6	5	1	6	7	
Varanasi-Ghazipur	144,000	30	6	2	-	2	-	1	-	4	3	3	-	2	1	-	6	5	79-108
Ghazipur-Varanasi	148,800	31	2	1	2	-	1	-	-	2	1	2	-	3	3	-	14	23	
Varanasi-Ghazipur	216,000	45	-	20	-	-	-	20	-	-	-	5	-	-	-	-	-	-	79-108
Nepal-Varanasi		0	-	-	-	-	-	-	-	-	-	-	-	-	-	-	-	130	
Kolkata-Ghazipur	40,000	59	-	-	-	-	-	-	-	-	-	-	59	-	-	-	-	-	687
Ghazipur-Kolkata		0	-	-	-	-	-	-	-	-	-	-	-	-	-	-	-	-	
Ghazipur-Mau		66	-	6	8	4	5	8	2	4	3	4	-	8	2	-	12	42	away from NW
Mau-Ghazipur		23	-	3	2	-	-	4	-	2	3	-	-	4	-	-	5	15	1
Azamgarh-Ghazipur		40	3	6	4	-	-	1	-	6	4	6	-	4	2	-	4	3	away from NW
Ghazipur-Azamgarh		17	-	1	2	-	1	-	1	2	3	-	-	3	-	-	4	16	1
Total	1,979,200	609	20	76	39	118	28	49	4	20	34	20	59	44	24	6	68	379	

Notes: *Other-Vegetable, Fruit, Coal, Bricks, wood, Furniture etc

Load per full truck (tons): 16

Operating days per year: 300

Source: PMU / IWA, 13 February and 19 February 2016

Transit Cargo

As to transit cargo, the Consultants rechecked their data as depicted in Annex 9. As can be seen in the orange-coded columns there, in no case would a deviation through a multi-modal terminal at Ghazipur be more cost-effective than through the terminals calculated by their transport model. O/D pairs crossing the NW-1 west of Ghazipur could be deviated more cost-effectively through an MMT at Ramnagar. For instance, wheat trucked from Jaunpur to Manihari and shifted onto the NW-1 at Ramnagar MMT would incur a total cost of 1502.8 Rs/ton (30.7% cheaper than pure trucking) as against 1592.5 Rs/ton if shifted at Ghazipur (26.6% cheaper than pure trucking). Similarly, O/D pairs crossing the NW-1 east of Ghazipur could be deviated more cost-effectively through an MMT at Ballia. For instance, rice trucked from Naugarh to Kolkata and shifted onto the NW-1 at Ballia would incur a total cost of 2840.1 Rs/ton (15.9% cheaper than pure trucking) as against 2887.9 Rs/ton if shifted at Ghazipur (14.5% cheaper than pure trucking). The Consultants would like to highlight that although their survey identified all potential cargo, their transport model considers only those cargo streams which are adjacent to the Ganges River and could be shifted onto the NW-1. Any other cargo which crosses Ghazipur perpendicular to the NW-1 can of course not be considered as potential cargo for this waterway.

Container traffic bound for Birgunj (Nepal) would be channeled more cost-effectively through an MMT at Patna, as also identified by the IFC expert. The reason is that the road distance from Patna to Birgunj (Nepal) is shorter than the distance between Ghazipur and Birgunj (Nepal). Additionally, the IWT distance from Kolkata to any multi-modal terminal (including Ghazipur) located upstream of Patna is larger and transport time therefore longer in comparison to Patna.

Summarizing the Consultants' investigation of three (local, regional and transit) cargo data bases and after thorough analysis, they come to the conclusion that predominantly short-distance shipping could provide a possible demand for a multi-modal Terminal at Ghazipur. Under very optimistic assumptions as laid down on the previous pages 3 and 4, total cargo would amount to about 3 MMT in the year 2020.

Table 109: Ghazipur Terminal - 2020-2045 forecast by loaded versus unloaded cargo (MAC, million tons)

Year	Load	Unload	Total
2020	0.96	2.38	3.35
2025	0.99	5.15	6.14
2035	1.01	5.58	6.59
2045	1.02	5.69	6.72

Source: Consultants' Market Survey July-October 2015, calculations by transport model

Figure 79: GhazipurMMT loaded versus unloaded cargo 2020-2045 (million tons)

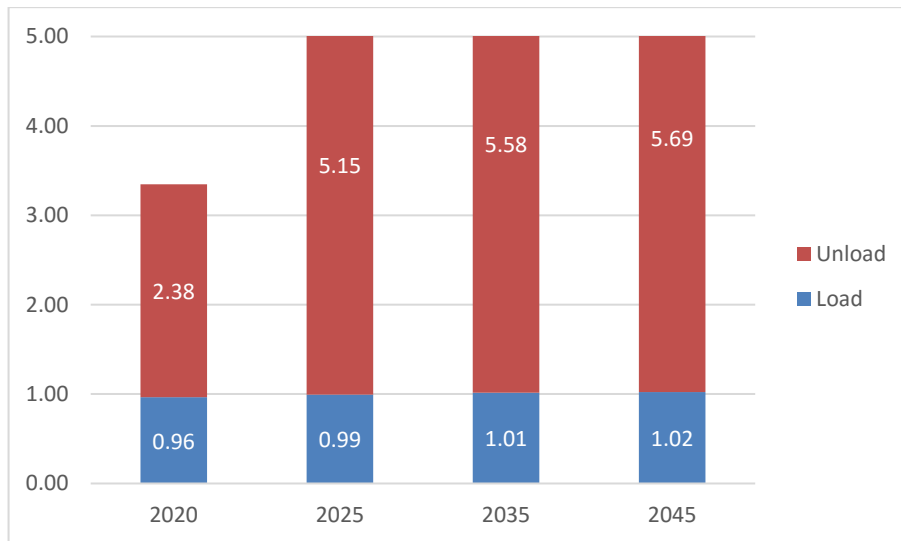

Source: Consultants' Market Survey July-October 2015, calculations by transport model

Table 110: Ghazipur Terminal - 2020-2045 cargo forecast by cargo type (MAC, million tons)

Year	Dry Bulk	Bagged	General Cargo	Total
2020	2.33	0.03	0.98	3.35
2025	5.10	0.03	1.01	6.14
2035	5.53	0.04	1.03	6.59
2045	5.64	0.04	1.04	6.72

Source: Consultants' Market Survey July-October 2015, calculations by transport model

Figure 80: Ghazipur MMT - 2020-2045 cargo forecast by cargo type (million tons)

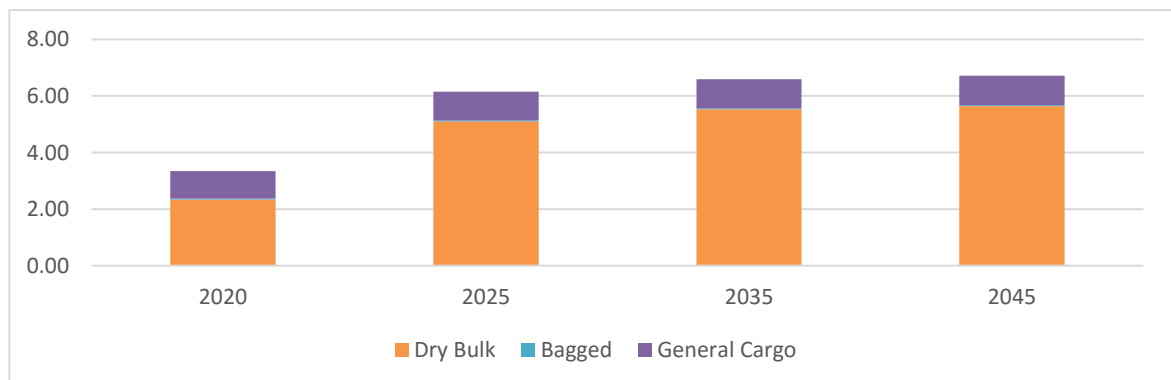

Source: Consultants' Market Survey July-October 2015, calculations by transport model

10.4.7 Kalughat Multi-modal Terminal

Kalughat, near Sitabganj about 20 km upstream of Patna gaighat, constitutes a second location which the GoI has earmarked for future medium-sized MMTs (see below Figure 81). A Kalughat MMT would be an ideal location for transferring containers, shipped on the NW-1 from Kolkata GRT, for onward trucking into the Katmandu Valley of Nepal. Also, no bridge needs to be crossed by truck traffic, as this area lies north of the Ganges River.

Figure 81: Regional location of Kalughat Multi-modal Terminal



Source: Google Earth; information by Howe India, 19 April 2016

Below map gives a closer view to the location of a future Kalughat MMT.

Figure 82: Possible location for an alternative multi-modal terminal at Kalughat

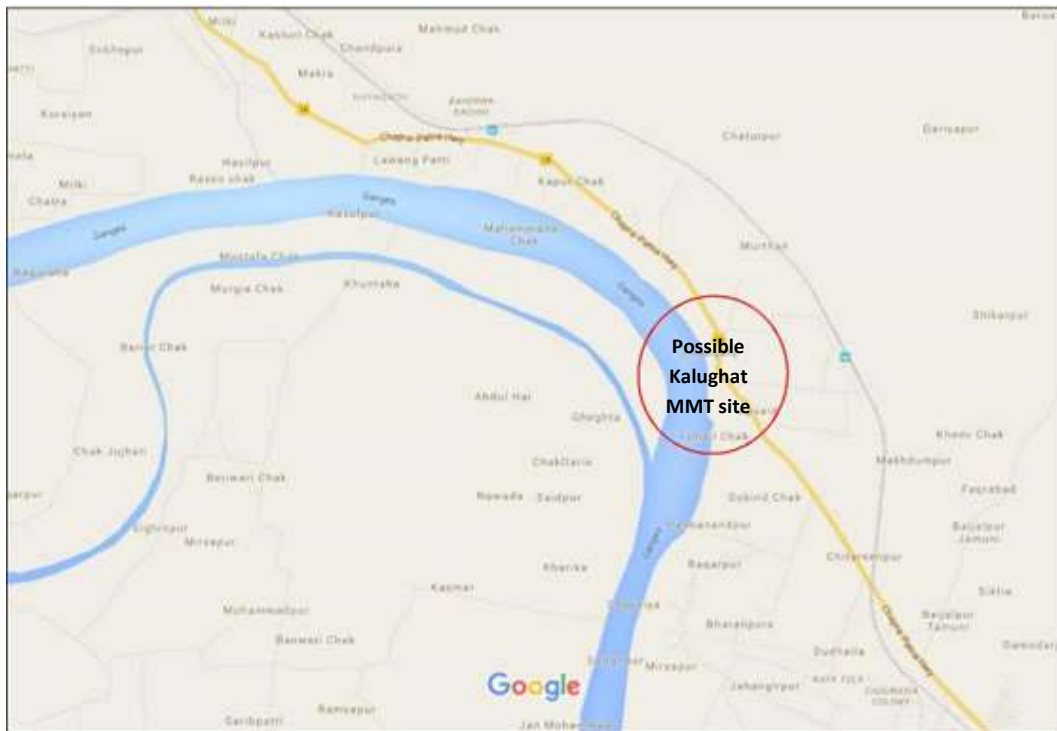

Source: Information by Howe India, 19 April 2016

Overleaf Table 109 indicates that traffic through a future Kalughat MMT would be concentrated on dry-bulk and containerized cargo (see Annex 10 for detailed figures).

Figure 83: Kalughat Terminal loaded versus unloaded cargo 2020-2045 (million tons)

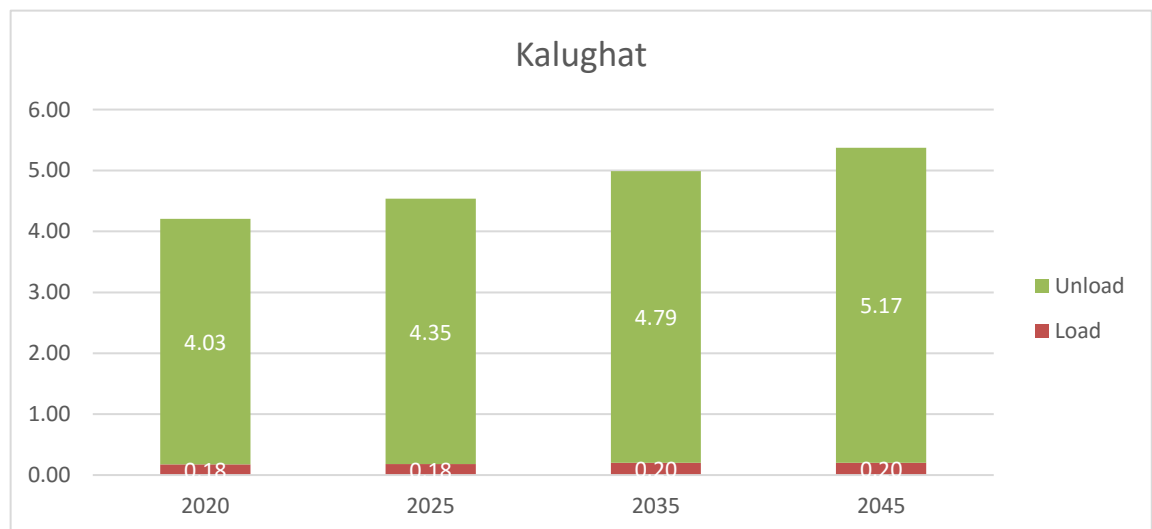

Source: Consultants' Market Survey July-October 2015, calculations by transport model

Table 111: Kalughat Terminal cargo forecast, 2020-2045 (MAC, tons)

Year	Bagged	General Cargo	Container	Total
2020	0.11	0.06	4.03	4.21
2025	0.12	0.07	4.35	4.54
2035	0.12	0.08	4.79	4.99
2045	0.12	0.08	5.17	5.38

Source: Consultants' Market Survey July-October 2015, calculations by transport model

Total cargo traffic in the year 2045 would amount to 5.38 MMT, of which more than 90% would constitute containerized cargo.

Figure 84: Kalughat Terminal - 2020-2045 cargo forecast by cargo type (million tons)

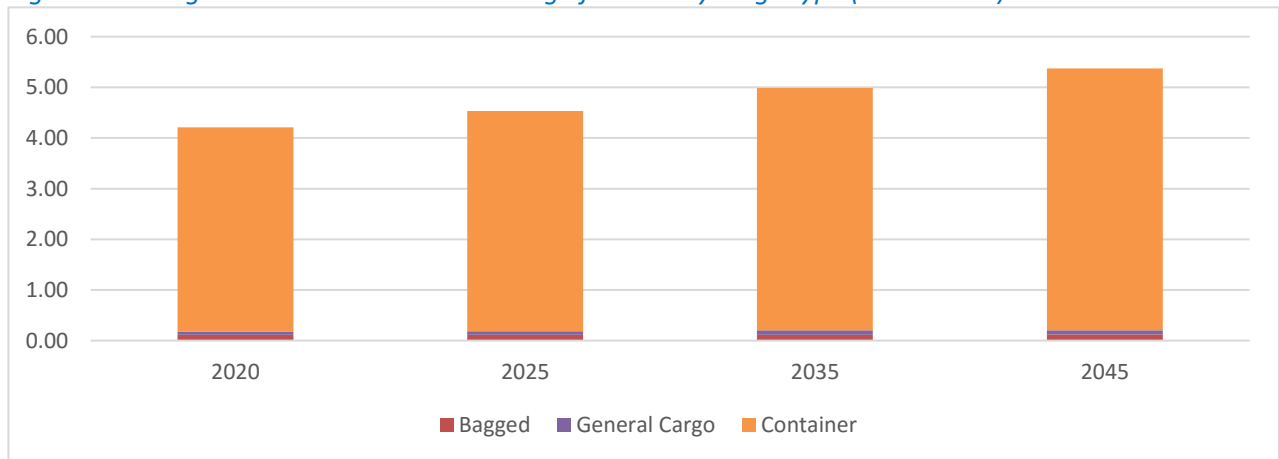

Source: Consultants' Market Survey July-October 2015, calculations by transport model

10.4.8 Tribeni transshipment terminal

Tribeni is located 53 km upstream of Kolkata respectively 158 km upstream of Haldia MMT. Tribeni constitutes one of three locations which the Gol has earmarked for a medium-sized transshipment terminal. The Consultants visualize the location depicted below as a possible site for transshipment operations.

Figure 85: Possible location for a transshipment terminal in Tribeni, W.B.

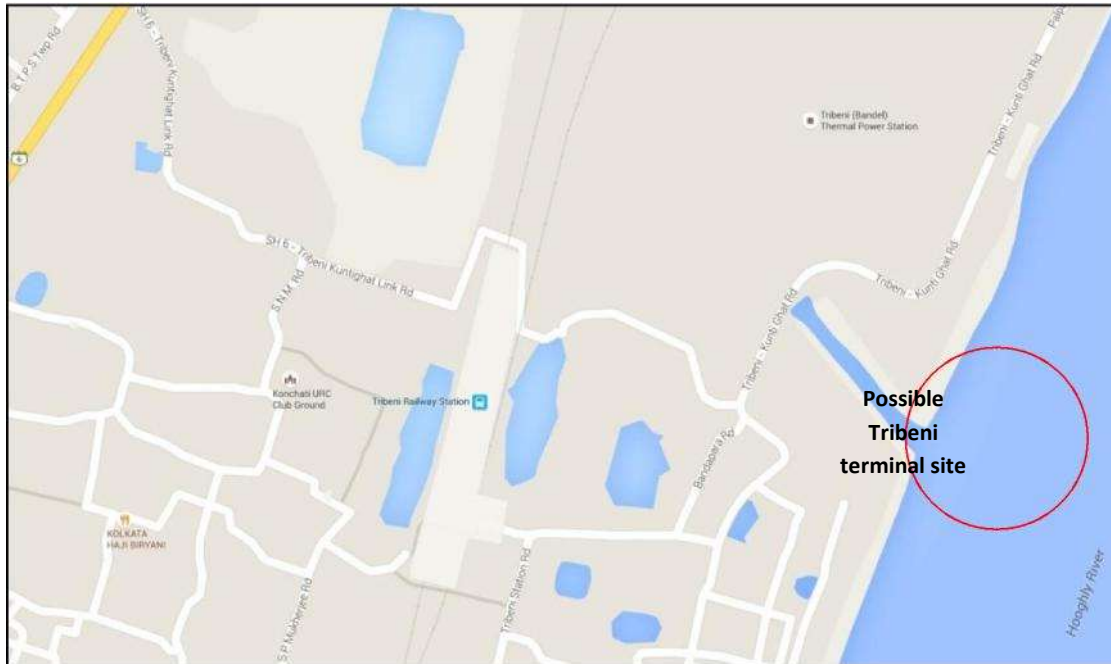

Source: Google Earth; Consultants' investigation

IWAI intends to tranship cargo between large ships (approximately 5,000 tons) and small vessels (2,000 tons). IWAI estimates that economies-of-scale will warrant additional costs of transshipment.

Overleaf Table 110 indicates the cargo amounts which could be transhipped at Tribeni (see Annex 11 for detailed figures). Basis of the calculation is the idea that during the monsoon season (approximately three months) the river has sufficient water depth 5,000-ton ships. The Consultants therefore calculated one-fourth (25%) of the cargo volumes forecast to be shipped past Tribeni (see Volume II: Final Transport Forecast Model for detailed figures).

Table 112: Tribeni transhipped cargo volume forecast, 2020-2045 (MAC, tons)

Cargo Type	2020	2025	2035	2045
Dry Bulk	1,523,469	2,050,099	3,169,547	3,580,848
Liquid Bulk	0	0	4,187	4,840
Bagged	28,514	105,514	178,589	199,428
Neo-Bulk	140,805	472,714	694,733	860,265
General Cargo	0	3,751	4,487	4,727
Container	215,186	319,900	1,776,738	2,315,551
Ro-Ro	0	0	21,042	28,052
Total	1,907,974	2,951,977	5,849,324	6,993,712

Source: Consultants' Market Survey July-October 2015, calculations by transport model

Of the cargo types depicted in the above table, IWAI envisages mainly bulk cargo to be transhipped at Tribeni (particularly coal and stone chips).

10.5 Demand distribution between various transport corridors and modes

For each planning horizon the distribution of future demand will be forecasted. Certain transport routes (O/D routes) as well as the transport modes in general will be considered.

The development of the transport modes is depending on several aspects like monetary and non-monetary as well as logistical and non-logistical. The relevance of the different aspect is expected to change during the years. The considered aspects are named below and their expected development and individual consideration in the distribution forecast are described as follows:

Monetary costs: It is expected that fuel and staff costs will continue to increase. Thus, saving of fuel as well as an as efficient as possible utilization of staff will be important for provision of viable transport services in the future.

Non-monetary costs: Non-monetary costs represent other sources of sacrifice or efforts than the above mentioned monetary costs. Besides the direct expenditure there are also other events or conditions generating additional efforts which influence the decision of choosing one transport or another. These are for example in general so called time costs and psychological costs. In detail these could be described by the terms like time saving, established procedures, safety as well as creation of an environmental friendly image. Finally all these aspects generate costs but they are “not visible” or expressed by a rate.

If the time saving aspect matters when choosing a transport mode it is important for the decision maker to transport the cargo very fast to its destination or to avoid delays by diminishing the risk of getting into traffic jams or other delays causing events. Psychological costs are generated e.g. by the fact that the decision maker prefers to stay with the already established procedures or transport mode respectively. Established procedures are ostensible reliable as they are known to the decision maker. Additionally it is quite convenient to stay with an established system (although it might cost more). According to statistics the different transport mode are more or less prone to accidents. The environmental issues like consideration of emissions or creation of an eco-friendly image by efforts to generate a comparative low carbon footprint per transport or similar are also non-monetary costs.

In the future e.g. the principles “National Mission for Clean Ganga” will become more and more important for the transport and logistics industry. It is on its way as a registered society originally formed by Ministry of Environment, Forests and Climate Change (MoEFCC) since on 12th August 2011. The aims and objectives of NMCG are to ensure effective abatement of pollution, water quality and environmentally sustainable development. It is expected that environmental efforts as well as economical efforts will be executed in a balanced way. By this it could be quite likely that for example new vessel engine technologies like the use of LNG powered engines will step more and more into the focus. These engines do generate lesser emissions than the conventional diesel powered engines.

Additionally it is expected that the establishment of “green ports” will continue. In 2015/16 for example Haldia will be declared as the first "green port" in the country for using bio-diesel in its operations. Probably this will also have an effect on the design of logistics chains as the use of certified or awarded port location will also be taken into account.

Logistical aspects: These aspects determine the choice of a transport mode considering logistics issues like availability of infra- and superstructure. If a warehouse is needed, than it

is important that a suitable facility is provided. Probably it is also important to have a good rail connection to use the advantages of this transport mode for further on transport. If certain loading, discharging or handling equipment are necessary their availability will influence the decision for or the structure of the supply chain. The ability of navigation aid is also something that will have an impact on the choice of transport. It is expected that all these technical issues will improve steady over the years and will become more and more supportive for the inland waterway.

Non-logistical aspects mainly cover cargo-related issues like certain storage temperature, continuous cooling chain, perishability, heating or similar. The more the cargo cannot be handled in a suitable standardized way the more influence these aspects have on the design and/or choice of the transport route.

Besides that also the political focus and direction is important. As the current PM has described his will to support and push the strengthening of IWT there are also efforts to comply with the "Vision 2020" which defines the aims how the railway sector should develop within the next Years. This paper has been published in June 2009. Some of the mayor targets related to cargo traffic are:

- Freight services would be transformed by segregation of freight and passenger corridors, construction of dedicated freight corridors, improving the speed of transit, cost-efficiencies in bulk transport and meeting the needs of customers in terms of service delivery, logistics services, transit time and tariff.
- Railways will aim at capturing 50% of the freight moving over 300 km distance and more than 70% of the bulk cargo moving in large volumes in the same distance range.

Currently the Ministry of Railways is working on a paper called "Vision 2030".

11 Socio Economic and Environment Benefits

11.1 Absolute and comparative benefits to environment due to the modal shift and transportation of cargo using IWT sector

General considerations

Inland Waterway Transport (IWT) offers a comparatively low cost and environmentally sound alternative to road and rail transportation especially for bulk and containerized cargo. Infrastructure requirements of IWT in comparison to road and rail transport are also relatively low, although some investments in port facilities, connecting road/rail infrastructure and the establishment and maintenance of waterways' minimum draft and for aids to navigation have to be made. Compared to other modes of transport which are often confronted with congestion and capacity problems, inland waterway transport is characterized by its reliability, its low environmental impact and its major capacity for increased exploitation.

It is therefore obvious that IWT can play a very important role when high quality ports and waterway connections are available in combination with high transport demand and industrial activities. In addition to a good waterway infrastructure, also connecting transport networks have to be established and have to work efficiently to make IWT attractive – road and/or rail connections should be available at a place of discharge/loading in order to transport the cargo to or from the producer or consumer of the transported cargoes as most of the production sites are not located directly at the river but some distance away.

Generally, Inland Waterways Transport is considered to be one of the environmentally friendliest ways of transportation.

At present, no information on the environmental performance of the inland waterway transport system in India or on the exact environmental figures of road and rail transport is available to compare the environmental performance of the different modes. Consequently, data and figures related to the sectors in the US and Europe are taken to illustrate the environmental impacts of IWT in general. Although the inland waterways sector of India differs from the situation in other countries, the overall environmental impact of the different modes of transport can be compared, based on the international data from Europe and the US.

Within this study, only the benefits and impacts to be expected due to modal shift and increased use of IWT are considered. The environmental impacts related to dredging, bandalling and construction are evaluated in a separate study executed by a different team of consultants.

In the following, different parameters influencing the environmental impacts of IWT are considered.

Emissions

- Carbon Dioxide CO₂
- Particulate Matter PM
- Nitrogen oxides (NO_x)
- Sulfur oxides (SO_x)

Environmental impact

Global warming
Human toxicity, summer smog, carcinogenic
Human toxicity, Acidification eutrophication,
eco-toxicity, summer smog
Human toxicity, Acidification, eco-toxicity

Waste – influencing the water quality

- Oily and greasy waste resulting from vessel operation (depending on the type of fuel used)
- Cargo related waste
- Sewage water, garbage, cleansing slurry and slops





Energy efficiency and related CO₂ production⁵⁴

The energy efficiency of inland waterways transport in comparison to other modes of transport, especially road transport, is generally much higher, as is indicated in many studies world-wide. To cite just a few of these studies, please find below examples for energy efficiency of the different modes of transport from the USA as well as from Europe.

Figure 86: Comparison of cargo capacity of different modes of transport

Cargo Capacity of Different Transportation Modes

Comparison of the cargo capacities of a barge, rail car, train, and semi truck (adapted from Iowa Department of Transportation)

Mode of Transportation	Tons of Cargo	Gallons of Cargo
 One Barge	1,500 tons	453,600 gallons
 One Rail Car	100 tons	30,240 gallons
 100-car Train Unit	10,000 tons	3,024,000 gallons
 Large Semi	26 tons	7,865 gallons

Source: Tennessee-Tombigbee Waterway, <http://business.tenntom.org/why-use-the-waterway/shipping-comparisons/>

⁵⁴ A very thorough and detailed analysis is done in the study on Long and medium term perspectives of IWT in the European Union, executed by the consortium of CE Delft, Planco, MDS Transmodal, viadonau and NEA for the European Commission Directorate-General MOVE published December 2011

However, these generalized figures should not be taken without considering the individual circumstances of each case. Sound calculations of energy consumption by different transport modes and their comparison must consider the specific conditions of transport. This includes: technical characteristics of vehicles, load factors of these vehicles, infrastructure characteristics and specific traffic conditions.

As an example, for road freight transport the traffic flow is decisive. According to complex model calculations, the average fuel consumption of trucks and truck-trailer combinations on German highways in 2005 was as follows⁵⁵:

- Unrestricted traffic flow: 29.2 liters per 100 km;
- Medium level of traffic disturbances: 30.8 liters per 100 km;
- Significant traffic disturbances: 31.8 liters per 100 km;
- Stop and Go: 61.9 liters per 100 km.

This example illustrates, that, in order to come to an unambiguous picture of actual environmental impacts, all figures related to transport and fuel consumptions must be considered for each individual logistics chain, respectively route.

Energy consumption related to rail freight transport also must consider specific transport conditions. Such specific conditions include: technical specifications of locomotives, number of wagons per train, train length, train gross weight, ratio of net to gross train weight, and train speed. Furthermore, specific conditions of selected routes (e.g. topography) and number of stops can be considered in order to come to a realistic picture.

The same applies to calculations related to inland waterways transport. Here, the load factor, the engine / propulsion / fuel used, the construction and the type of vessel, the current as well as the pre-haulage plus end-haulage to and from the transshipment sites, to name just a few factors, must be considered.

In general terms the below figure illustrates the energy efficiency of the different modes of transport and lead to a very positive picture of IWT when compared to road and rail.

Figure 87: Energy efficiency of different modes of transport



Source: Tennessee-Tombigbee Waterway, <http://business.tenntom.org/why-use-the-waterway/shipping-comparisons/>

⁵⁵ Economical and Ecological Comparison of Transport Modes Road, Railways, Inland Waterways PLANCO 2007
at: http://www.bafg.de/DE/08_Ref/U1/03_Projekte/05_Verkehrstraeger/verkehrstraeger_kurz_engl.pdf?__blob=publicationFile (21.09.2015)

Figure 88: Comparison of distances transported for one ton of freight given the same energy input

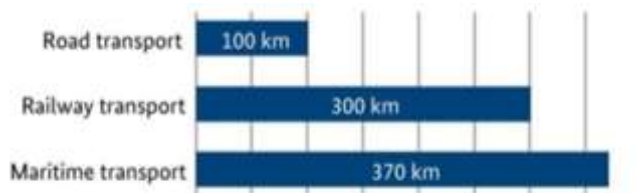

Source: Federal Waterways and Shipping Administration

Source: German Federal Waterways and Shipping Administration, <http://www.inefficiency-from-germany.info/ENEFF/Navigation/EN/Energieeffizienz/Transport/InlandWaterways/inland-waterways.html>

Other emissions

Not only CO₂ emissions have to be considered when evaluating the environmental impacts of the different modes of transport, but other gases like hydrocarbons, carbon monoxide and NO_x must be taken into account. Some studies show that even the emissions of these other gases are favorable if compared to road transport. One example is given in the figure below.

Figure 89: Comparison of emissions per ton-mile

Environmental Quality of Shipping Methods

Comparison of the emissions of different gases into the atmosphere from different shipping methods
(Source: C. Jake Hauk Ph.D. - Inland Waterways as Vital National Infrastructure: Refuting "Corporate Welfare" Attacks)

Mode of Transportation	Hydrocarbons Emitted (lb/ton-mile)	Carbon Monoxide Emitted (lb/ton-mile)	Nitrous Oxide Emitted (lb/ton-mile)
	0.0009	0.0020	0.0053
	0.0046	0.0064	0.0183
	0.0063	0.0190	0.1017

Source: Tennessee-Tombigbee Waterway, <http://business.tenntom.org/why-use-the-waterway/shipping-comparisons/>

The above figure shows that the emissions of hydrocarbons, carbon monoxide as well as nitrous oxide emitted per ton-mile are much lower in IWT, especially compared to road transport, thus indicating that a shift to inland waterways transport from road or rail would have positive environmental impacts indeed.

However, inland navigation vessels need to fulfill some prerequisites in order to reach the highest environmental standards and thus be the environmentally friendliest mode of transport. Below, some of these prerequisites are listed.

- The use of low or no polluting energies (low sulfur or sulfur-free diesel, LNG, electricity, etc.):
- Installation of state-of-the-art engine and propulsion arrangements;
- Selective Catalytic Reduction (SCR) (to reduce nitrogen oxides NO_x and Particulate Matter emissions)
- Installation of Particulate Matter filter
- Speed regulator giving advice on fuel economic operating speed

There are undoubtedly positive impacts to be expected from shift to inland waterways transport from road transport as far as the reduction of CO₂ is concerned, because IWT has relatively low energy consumption in relation to tons/volumes of cargo transported and thus a low carbon footprint. Noise and environmental impacts from infrastructure are also rather low. Also, IWT decreases the burden on the transport network – if more goods are transported by waterway, there is less traffic on the roads leading to better transport flow for the remaining traffic and less deterioration of road infrastructure and finally to less CO₂ production resulting from road transport. Further, the railway system can be released from part of the burden, freeing capacities for passengers and for cargoes not fit to be transported by water.

However, looking at the pollution resulting from other pollutants like particulate matters, NO_x and SO_x, the situation is not so unambiguous. Air pollutants, including NO_x and sulfur dioxide (SO₂) as well as particulate matter, are directly emitted into the air due to fuel combustion. Here, the impacts of transport heavily depend on the quality of fuel and the state of the art of the engines / propulsion of the inland waterways vessels used.

A recent study comparing the impact of transport using diesel as fuel comes to the following conclusion regarding the environmental impacts of goods transported by truck, rail and inland waterways – all using diesel engines - from Vienna, Austria to Budapest, Hungary. The graph below clearly shows that road transport uses more fuel to transport the same amount of goods; however, despite the bigger fuel consumption the emission of particulate matters is by far higher in inland waterways transportation. This figures shows that the transport mode with the lowest energy consumption is the railway. Here it has to be taken into account, that in many parts of Europe, the railways is running electrically and not on fossil fuel, which leads to lower greenhouse gas emissions. (It should be noted that most IWT craft – and also their engines - in that area are in the age bracket of 40 to 50 years).

Figure 90: Comparison analysis between road, rail and IWT emissions

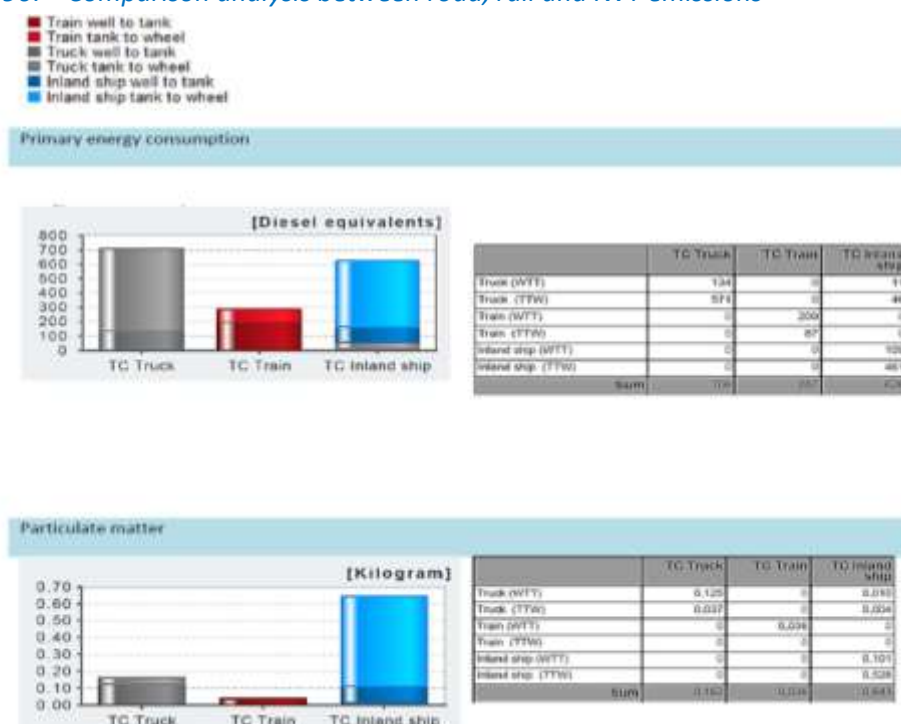

Source: United Nations Economic Commission for Europe: Diesel Engine Exhausts – Myths and Reality, p. 27f

This comparison shows that although there is a high potential for environmentally friendly inland waterways transport, IWT must invest in advanced technology to stay ahead of the competing transport modes.

The Central Commission for the Navigation of the Rhine also states in an inspection report: "... However, the other carriers that compete with inland navigation are making advances in reducing their greenhouse gas emissions. If inland navigation wants to retain its competitive advantage as being "environmentally friendly", it also needs to further reduce its greenhouse gas emissions."⁵⁶

Waste

As many of the fears expressed by stakeholders (fishermen, inhabitants of adjacent communities) related to new terminal construction and increase of inland waterway transport concerned potentially increased water pollution of the rivers, water polluting waste is also briefly addressed within this study.

Following the classification of the Central Commission for the River Rhine in Europe, the waste is divided into three categories, as mentioned above:

- Oily and greasy waste resulting from vessel operation
- Cargo related waste
- Sewage water, garbage, cleansing slurry and slops

Rivers are invaluable and unique ecosystems with unique aquatic life – in the case of the river Ganges dolphins and turtles are especially valuable species in certain areas, next to different fish – and they also provide livelihood for fishermen and serve as freshwater supply for neighboring communities as well as for religious purposes. Therefore, water pollution from any source should be prevented. The only way to ensure that pollution is prevented and waste collected in dedicated facilities and brought to proper treatment, is to set up environmental rules and regulations for the IWT sector and, of course, take care of enforcement of these regulations.

In Europe, inland waterway transport plays an important role, especially on the Rhine and Danube and their connecting canal systems. At the same time, environmental consciousness is well developed in the European societies. In order to prevent water pollution, international agreements for pollution prevention and treatment of waste, respectively avoiding waste, have been elaborated and implemented. One example how to prevent pollution and deal with waste is the International Convention on the Collection, Deposit and Reception of Waste generated during Navigation on the Rhine and other Inland Waterways, elaborated in 1996 and in force since November 2009. The rules stipulated in the Convention aim at⁵⁷

- encouraging the prevention of waste generation,
- facilitating the disposal to the dedicated waste reception facilities along the waterway network,

⁵⁶ Possibilities for reducing fuel consumption and greenhouse gas emissions from inland navigation - Summary of the report by the Inspection Regulations Committee for the 2012 Autumn Meeting (Annex 2 to protocol 2012-II-4 of the Central Commission for the Navigation of the Rhine, 29 November 2012), p.3.

⁵⁷ <http://www.cdni-iwt.org/en/presentation-of-cdni/> (accessed 22 Sep 2015)

- ensuring adequate funding in view of the “polluter-pays principle”, and
- facilitating compliance with the prohibitions of discharge of the waste into surface water.

Part A of this convention deals with wastes arising from operating the vessel. Wastes occurring in the engine room are specifically addressed: i.e. used oil, bilge water, used grease, used cloths, used filters and similar wastes. To dispose of these wastes, a network of special waste reception vessels is installed all over the European inland waterways to ensure easy access for the inland waterways barges and vessels. This network consists mostly of oil separator vessels that dock on to vessels during passage. As these wastes occur in any type of vessel, the costs for installing and maintaining these facilities are shared by all vessels via a special “disposal fee” which has to be paid by all vessels. The amount is calculated for all types of vessel on the same basis – based on the amount of diesel bunkered. For each 1000 liters of diesel, a disposal fee of 7.50 Euro is due. The amount is the same for any type of vessel and entitles the vessels to dispose of their waste free of charge.

Part B deals with handling cargo residue and waste that are due to the shipment of cargoes. The main aim is to minimize cargo residues that have to be collected and treated as waste by optimizing the discharge procedures of the vessels. The regulations prescribe certain standards for discharge, depending on the characteristics of the individual cargo. The correct execution of the discharge procedures has to be confirmed by the recipient of the cargo by issuing a special document to the ship. In this document it also has to be stated, where cargo residues are brought to in case they do not remain at the cargo recipient.

Part C takes care of “household waste” – sewage water, garbage, sludge and slop. In this respect, special attention has to be paid to ferry and passenger vessels as they can accommodate a huge number of persons, leading to high volumes of this type of waste, which must not be thrown or pumped into the water. Cargo vessels can usually dispose of their garbage in waste collection installations installed directly at the landing facilities. Ferry and cruise vessels have to collect the garbage on board and hand it over to commercial garbage treatment companies which have to be paid. Sewage water and slop must be either collected on board, and handed over to special facilities at shore, or have to be treated on board. The cleared water can then be released into the rivers, but the residue sludge must be kept on board and handed over to special reception facilities.

The procedures as well as the fees to cover the costs for implementation are regulated in the convention. To ensure that a similar system can be implemented in India, first of all the political will of the states has to be there and then a joint system to enforce these rules has to be in place. But international examples like the one briefly introduced above show that it is possible to ensure that the water quality will not be compromised by inland waterway transport⁵⁸.

⁵⁸ More ideas on how to deal with ship generated waste and waste water can also be found e.g. in the EU-financed CO-WANDA Project dealing with the Danube river (CONvention for WAsTe management for inland Navigation on the Danube), web-site: <https://co-wandaproject.eu/home.html>

Conclusions

All in all it can be stated that IWT is an environmentally friendly mode of transport and that a shift especially from road transport to inland waterway transport will generate environmental, but also social benefits. Numerous studies of fuel efficiency have been conducted and practically every one of these studies shows similar results; that is that inland waterway transport is the most fuel efficient mode of transportation for moving bulk raw materials and bulky goods (like heavy lifts, over-dimensioned units, project cargo, etc.); it is the least energy intensive method of freight transportation when moving equivalent amounts of cargo, and it consumes less energy than alternative modes per ton-kilometer. These factors, combined with the remoteness of the vessels' operating environment from population centers, substantially reduce the impact of its exhaust emissions, especially in comparison with road transport.

For inland waterways transport as well as for rail transport, the volume of cargo transported, but also the type of engine or propulsion used determine the specific emissions and thus the environmental impacts for a trip. The more cargo is transported by one vessel per one trip, the higher the environmental benefits. Next to these factors, the pre and end-haulage have to be considered in order to come to a realistic picture of emissions produced by the entire transport of a certain cargo. However, it can be clearly stated, that only in extraordinary cases the emissions of IWT (or railway) are higher than those of road transport. This might only happen in case of a very low load factor, e.g. in the low water periods when the vessels cannot be fully loaded.

In order to ensure highest environmental benefits of inland waterways transport, strict emission regulations for IWT should be elaborated and implemented. Next to reducing fuel consumption, these might include among others the allowed levels of emissions for Particulate Matter as well as for nitrogen oxides (NOX) and SOX, requiring for example the use of low sulfur or sulfur-free diesel.

Low sulfur or sulfur-free fuel will in itself reduce emissions considerably (SOX by 98% and PM by 17%), but is also a prerequisite for application of various other emission reduction techniques achieved after treatment of the emissions, like SCR catalysts, soot filters etc. By using these techniques 80% to 90% of the remaining NOX and PM in the exhaust gasses can be reduced⁵⁹. New engines can easily cope with low sulfur fuel or sulfur-free fuel (modern diesel engines in cars operate on sulfur-free diesel), but given the fact that marine diesel engines have a long life span of approximately 20 years, old engines are still in place. In case of these old engines fuel additives or fuel type adapted lubricants will have to be used in order to enable them to run with low sulfur diesel.

If no stringent regulations are applied, the environmental gap between road transport and IWT will rapidly become smaller in India, like already nowadays in Europe. In Europe, a major concern thereby is the poor progress made on the emission of air pollutants, in particular with the emission of NOX and Particulate Matter. In contrast to the road haulage sector the emission standards for new engines in IWT are much less stringent and the average lifetime of engines in inland vessels is very long; therefore, the implementation of large-scale innovations

⁵⁹ European Barge Union: EBU-Statement on Inland Navigation and Environmental Sustainability in the Danube River Basin, 25 June 2007

takes comparatively long time. Consequently, inland waterway transport already has higher air pollutant emission levels than road transport per ton-kilometer for certain vessel types.⁶⁰

In order to ensure that IWT will remain the environmentally friendliest way of transport, a combination of lower emission limits, low sulfur or sulfur-free diesel fuel and financial incentives for implementation of emission reduction techniques will have to be implemented to achieve a major improvement in emission reductions from inland navigation.

Another way to reduce emissions is of course the use of fuel saving technologies, by using new propulsion system technologies, modern construction material and resistance-reducing scantlings for vessels. Lower fuel consumption not only leads to lower emissions but also reduces operating costs and is therefore generally attractive for ship owners. Also in this area, the implementation of state incentives like tax reduction for ships constructed with special material and innovative, fuel saving shape as well as state of the art propulsion engines will assist to achieve good environmental standards in IWT and ensure that not only the executions of a future increase of mass bulk transport but also a future modal shift to inland waterway transport will bring high environmental benefits.

As in India the IWT sector is still under development and working on a very low level of transport activities there is a big chance for India to start the development of the sector with the use of state-of-the-art vessels which take environmental and fuel efficiency concerns into consideration in vessel construction and propulsion. This way, India could ensure that due to the application of latest technologies the modal shift to inland waterways transportation really leads to measurable environmental benefits. Many of the transports will be dedicated transports of for example coal to a power plant or other raw materials to dedicated end users. Such transports on dedicated transport routes that work in a dedicated, long-term supply chain, can reap the greatest ecological and economical benefits by being performed by specialized, dedicated vessels with advanced vessel and propulsion technologies. European examples show that in cases where more or less dedicated transports take place, ship owners build dedicated vessels which can be optimized for a given route.

Given the fact that especially bulk cargo lends itself for IWT environmental benefits will arise by shifting this type of cargo transport from road to inland waterways. One motorized inland waterways vessel with a load of 2,000 tons carries as much cargo as 50 railway cars at 40 tons each or 80 trucks at 25 tons each⁶¹. Combined with comparably low transport costs, inland vessels show an excellent cost-benefit-ratio.

Next to bulk cargo, also project and out-of-gauge cargo can easily be transported by inland waterways vessels. Due to their size and loading capacity, inland vessels are especially suitable for transporting goods with unusual sizes and weights like transformers, turbines and the like.

Both the two other modes of transport – road and rail – often already work at capacity limit and suffer from congestion in the case of road and capacity problems in case of the railway. Thus, inland waterways with a lot of free capacity can help to remedy this situation and offer comparatively low cost, environmentally friendly and reliable services.

⁶⁰ United Nations Economic Commission for Europe: Diesel Engine Exhausts – Myths and Reality, p.24ff.

⁶¹ EU financed 7th Framework Program – PLATINA II Project

12. Annexes

Annex 1: List of Market-Survey Interviews

Haldia-Farakka Sector

Sl No.	Date of Interview	Name of Company/ Organisation	Function	Location	Agenda	Remarks
1.	05-Aug-2015	Agro Suppliers Syndicate	Producer cum Supplier of Agro Equipment and Supplies	16, Ganesh Chandra Ave 4 th floor, Kolkata.	Surveyed cargo volumes and rate of transportation in Kolkata area and also about the O/D pairs	Very Co-operative
2.	05-Aug-2015	Debson Pumps Pvt Ltd	Agro equipment manufacturer/supplier	14, Bentink St, Kolkata	Surveyed cargo volumes and rate of transportation in Kolkata area and also about the O/D pairs	Very Co-operative
3.	05-Aug-2015	Ranjan Agro Industrial Co.	Agro equipment Supplier	Marshal House , 33/1, N.s.Rd, Kolkata	Surveyed cargo volumes and rate of transportation in Kolkata area and also about the O/D pairs	Problems in understanding questionnaire but cooperative
4.	27-Jul-2015	Chandok & Associates	Order supplier of Aggregates/Stone chips)	RDB Boulevard, 8 th Flr, Sector V, Salt Lake City, Kolkata-700091	Surveyed cargo volumes and rate of transportation in Pakur, Nalhati and Kolkata area and also about the O/D pairs	Very Co-operative
5.	04-Aug-2015	Aero Agro Chemical Industries Ltd	Manufacturer of Agro Chemical	R.N Mukherjee Rd, Kolkata	Surveyed cargo volumes and rate of transportation in Kolkata area and also about the O/D pairs	Problems in understanding questionnaire but cooperative
6.	03-Aug-2015	CTS Industries Ltd	Manufacturer/Order supplier of Aggregates & Stone chips	37 Shakespear Sarani, Kolkata	Surveyed cargo volumes and rate of transportation in Pakur, Nalhati, Sahibgunj and Kolkata area and also about the O/D pairs	Although promised to share data through questionnaire but could not deliver same due to reluctant attitude / Yet to receive infos on Questionnaire pending
7.	05-Aug-2015	JVL Oil Refinery	Manufacturer / supplier of Edible Oil	AJC Bose Rd, Kolkata	Surveyed cargo volumes and rate of transportation 8.etc in Haldia area and also about the O/D pairs	Although promised to share data through questionnaire but could not deliver same due to reluctant attitude / Yet to receive infos on Questionnaire pending
8.	17-Aug-2015	ACC Ltd	Manufacturer / Supplier of Cement, Concrete	Damodar Cement Works P.O. Sunuri 723 121 Madhukunda District Purulia West Bengal / Sindri Cement Works P.O. ACC Colony, Pin- 828 124 District Dhanbad, Jharkhand	Surveyed cargo volumes and rate of transportation etc in all West Bengal area and also about the O/D pairs	Very Co-operative
9.	19-Aug-2015	Tirupati Vessels Pvt Ltd	Barge /Tug Owner; Commodity handled Fly Ash on NW-1	Sarat Bose Rd, Kolkata	Surveyed cargo volumes and rate of transportation etc on NW-1 and Bangladesh area and also about the O/D pairs	Although promised to share data through questionnaire but could not deliver same due to reluctant attitude / Yet to receive infos on Questionnaire pending

10.	19-Aug-2015	Krishna Shipping & Logistics	Barge/Tug Owner; Commodity handled ODCs on NW-1 & NW-2	Diamond Chambers, Chowringhee, Kolkata	Surveyed cargo volumes and rate of transportation etc in NW-1 and NW-2 area	Problems in understanding questionnaire but cooperative
11.	07-Aug-2015	Ruchi Soya Industries Ltd	Producer of Edible Oil	Shakespeare Sarani, Kolkata	Surveyed cargo volumes and rate of transportation etc in Haldia area and also about the O/D pairs	Although promised to share data through questionnaire but could not deliver same due to reluctant attitude / Yet to receive infos on Questionnaire pending
12.	06-Aug-2015	Pioneer Agro Industries	Producer of Fertilizers	K.S.Roy Rd, Kolkata – 1	Surveyed cargo volumes and rate of transportation in Kolkata area and also about the O/D pairs	Problems in understanding questionnaire but cooperative
13.	06-Aug-2015	Adhunik Power & Natural Resources Ltd	Thermal Power Industries	AJC Bose Rd, Crescent Towers, Kolkata/Haldia	Surveyed cargo volumes and rate of transportation etc in Haldia area and also about the O/D pairs	Although promised to share data through questionnaire but could not deliver same due to reluctant attitude / Yet to receive infos on Questionnaire pending
14.	12-Aug-2015	Jindal ITF Ltd	Barge operator- Transporting coal from Sagar Is to Farakka	Shakespear Sarani, Kolkata	Surveyed cargo volumes and rate of transportation etc in NW-1 area and also about the O/D pairs	Very Co-operative
15.	11-Aug-2015	Bothra Shipping Services Pvt Ltd	Forwarder & Terminal Operator	Kolkata, Paradip Port, Bhubaneswar, Visakhapatnam Port, Kakinada Port, Krishnapatnam Port, Mangalore Port	Surveyed cargo volumes and rate of transportation etc in Kolkata port area and also about the O/D pairs	Very Co-operative
16.	17-Aug-2015	TCI Seaways	Multimodal Integrated Supply Chain Solutions Provider	TCI House, 69 Institutional area, Sector-32, Gurgaon-122007	Surveyed cargo volumes and rate of transportation etc in Kolkata/Haldia port area and also about the O/D pairs	Very Co-operative
17.	01-Sept-2015	Shri Shyam Agro Bioatech Pvt Ltd	Producer of Agro Products - Wheat Flour (Atta), Flour (Maida) and Cattle Feed	Raniganj, W.B.	Surveyed cargo volumes and rate of transportation etc in Raniganj, West Bengal area and also about the O/D pairs	Problems in understanding questionnaire but cooperative
18.	01-Sept-2015	BABA Ispat Pvt. Ltd	Producer of Iron & Steel	Raniganj, W.B.	Surveyed cargo volumes and rate of transportation etc in Raniganj, West Bengal area and also about the O/D pairs	Problems in understanding questionnaire
19.	03-Sept-2015	Lafarge India Pvt Ltd	Producer of Cement	Mejia, Vill-Amdanga, Bankura, -722183, W.B.	Surveyed cargo volumes and rate of transportation etc in Bankura Dist, West Bengal area and also about the O/D pairs	Very co-operative
20.	29-Aug-2015	Birla Corporation Ltd	Producer of Cement	Durgapur Cement Works, Durgapur-713203, W.B.	Surveyed cargo volumes and rate of transportation etc in Durgapur Dist, West Bengal area and also about the O/D pairs	Very co-operative
21.	13-Aug-2015	United Phosphorus Ltd	Producer of Raw Materials of Insecticides	Near Durgachawk Town, Haldia	Surveyed cargo volumes and rate of transportation etc in Haldia area and also about the O/D pairs	Very co-operative

22.	04-Aug-2015	Bicco Agro Products pvt Ltd	Producer of Fertilizers	Kolkata – 69	Surveyed cargo volumes and rate of transportation etc in Haldia area and also about the O/D pairs	Problems in understanding questionnaire but cooperative
23.	18-Aug-2015	ABC India Ltd	Project Logistics and Retail Transporter (FTL) for ODC/H-Lift transportation	40/8, Ballygunj Circular Rd, Kolkata-700019	Surveyed cargo volumes, Equipment owned and rate of transportation etc in Kolkata/ Haldia / NW-1 & NW-2 area and also about the O/D pairs	Very co-operative
24.	25-Aug-2015	J M BAXI & CO.	Ship Agents, Forwarder, Port and Terminal operator / Commodity – Containers, Bulk & Project cargo	Kolkata	Surveyed cargo volumes and rate of transportation etc in Kolkata/ Haldia area and also about the O/D pairs	Very co-operative
25.	10-Aug-2015	Aishwarya Shipping & Logistics, Kolkata	Customs Agent , Forwarder / Commodity – Refractory Cargo	Kolkata	Surveyed cargo volumes and rate of transportation etc in Kolkata/ Haldia area and also about the O/D pairs	Co-operative
26.	10-Aug-2015	Everett India Pvt Ltd	Shipping Agent / Commodities handled – Steel, General Cargo, Lime Stone, Coal	50, Chowringhee Rd, Kolkata-71	Surveyed cargo volumes and rate of transportation etc in Kolkata/ Haldia area and also about the O/D pairs	Co-operative
27.	10-Aug-2015	Eastern Navigation Pvt. Ltd.	Shipping Line (River Transporters only) / Commodities handled – Heavy Lift – ODCs	Mercantile Buildings, 2nd Floor, 9/12 Lal Bazar Street, Kolkata-700001	Surveyed cargo volumes, Equipment owned and rate of transportation etc in Kolkata/ Haldia / NW-1 & NW-2 area and also about the O/D pairs	Very co-operative
28.	12-Aug-2015	Karnani Minerals Pvt. Ltd	Trader / Commodities handled – Lime Stone, Silica Sand	Kolkata	Surveyed cargo volumes and rate of transportation in Kolkata area and also about the O/D pairs	Very co-operative
29.	10-Aug-2015	Vivada Corporation Pvt Ltd	Inland Barge Operator / Commodities handled – Petroleum Products	14 Southern Ave, (Dr Meghnad Saha Sarani)3 rd Floor, Kolkata 700 026	Surveyed cargo volumes, Equipment owned and rate of transportation etc in Kolkata/ Haldia / NW-1 & NW-2 area and also about the O/D pairs	Very co-operative
30.	13-Aug-2015	Royal Movers India	Integrated Logistic Service provider (Road Transportation)	B. H. Road, Kolkata - 700104	Provided Road Transportation rate for Individual Commodity as per different O/D pairs	Very co-operative
31.	13-Aug-2015	TATA Chemicals Pvt Ltd	Producer of Chemicals	Durgachak, Haldia	Surveyed cargo volumes and rate of transportation in Haldia area and also about the O/D pairs	Although promised to share data through questionnaire but could not deliver same due to reluctant attitude or may be unwilling to share same / Yet to receive infos on Questionnaire pending
32.	13-Aug-2015	Hindustan Uni-Lever	Producer of Detergent materials	Durgachak, Haldia	Surveyed cargo volumes and rate of transportation in Haldia area and also about the O/D pairs	Although promised to share data through questionnaire but could not deliver same due to reluctant attitude or may be unwilling to share same / Yet to receive infos on Questionnaire pending

33.	17-Aug-2015	Prism Logistics	Logistic Service Provider	Kolkata	Surveyed cargo volumes and rate of transportation in Kolkata/Haldia area and also about the O/D pairs	Although promised to share data through questionnaire but could not deliver same due to reluctant attitude or may be unwilling to share same / Yet to receive infos on Questionnaire pending
34.	04-07-Aug-2015	28 more Companies	Agro/Fertilizers industries	Kolkata / Howrah Market area	Problems in understanding questionnaire	No infos received due to reluctant attitude of sharing data
35.	04-Sept-2015	New Shankar Stone Works	Crusher Owner / Supplier of Aggregates	Bahadurpur, Nalhati, W.B.	Problems in understanding questionnaire	Data received verbally
36.	04-Sept-2015	Sharda Stone Works	Crusher Owner / Supplier of Aggregates	Bahadurpur, Nalhati, W.B.	Problems in understanding questionnaire	Data received verbally
37.	04-Sept-2015	Rohan Industries	Crusher Owner / Supplier of Aggregates	Bahadurpur, Nalhati, W.B.	Problems in understanding questionnaire	Data received verbally
38.	31-Aug-2015	Eastern Railway Authorities	Railway rate/Volume inquiry	Koilaghat, Kolkata	No data shared on the commodities, O/D pairs, rates etc	Data collected from Railway website.
39.	01-Sept-2015	Pakur Railway Authority	Railway rate/Volume inquiry	Pakur, Jharkhand	Shared only Railway volume and rate data	Data received verbally
40.	13-15-Sept-2015	Eastern Freight Corridor Corporation of India	Railway rate/Volume inquiry	New Alipore, Kolkata	Unable to share the actual volume/rate data	Projected data information collected from website as advised by them.
41.	14-15-Sept-2015	HDC Railway	Railway rate/Volume inquiry	Chiranjibpur, Haldia	Surveyed cargo volumes, O/D pairs, rate etc by Railway transportation from HDC	Still awaiting data
42.	31-Aug to 05-Sept-2015	At least 70 interviews in Pakur (50), Nalhati (5) and Rampurhat (15) areas were roadside interviews as per locations of different stone-chip crushers. Most of them were not ready to share data. Some of them shared only O/D pairs but unable to provide other data. Out of these 70 interviews, only 6 interviews resulted in complete data collection within these regions. All data were received verbally.				

Source: Consultants' Market Survey July – October 2015

Terminal and shipping operators interviewed:

1. Bothra Shipping Services Pvt Ltd / Forwarder & Terminal Operator / Established: 1977 / Location: Kolkata, Paradip Port, Bhubaneswar, Visakhapatnam Port, Kakinada Port, Krishnapatnam Port, Mangalore Port / Nos. of Staff: 358, / Nos. of Transport Devices: Tippers 124, Payloaders 45, Excavators 18, Excavators With Grabs 5, Liebherr Shore Cranes Lhm 400/550: 8, Lhm 984; 2.
2. TCI Seaways (TCI House, 69 Institutional area, Sector-32, Gurgaon-122007) / Multimodal Integrated Supply Chain Solutions Provider with a global presence / Established: 1958 / Location: 1100 locations all over India / Staff: 5,000+ / with extensive infrastructure, TCI today moves 2.5% of India's GDP by value. Over 9,000 trucks in operation / Fleet of 4 cargo ships / 10.5 million sq.ft. of warehousing space / CHA license.
3. Vivada Corporation Pvt Ltd. (14 Southern Ave (Dr Meghnad Saha Sarani) 3rd Floor, Kolkata 700 026 [Email: vivadakolkata@yahoo.co.in](mailto:vivadakolkata@yahoo.co.in)) / Inland Barge Operator / Established 1966 / No. of Staff: Permanent 140, Contract 90.

Farakka-Munger Sector

Sr. No	Survey Period	Organization/Company	Industry	Location	Reason	Remarks
1	29-Jul-15	M/s. Ammadia Mines	Stone Chips and Aggregates	Sakrigali	Current mode of transportation includes road and railway and the players look at IWT as an alternative. Could be a potential for IWT and hence surveyed.	As a general remark on the interview process and responses received, it was found that the mining agencies and industries were highly resistant to sharing information on the characteristics of the company/establishment, individual production capacity, future growth and costs involved. Albeit, they were expressing a favorable response to the proposed new IWT facility, there was ambiguity in the cost advantages and operational issues. This resulted in unclear response to questions like "their interest" and "investment in developing Sahibganj MMT".
2	29-Jul-15	M/s. Dilip and Brothers Stone Works	Stone Chips and Aggregates	Sakrigali		
3	3-Aug-15	M/s. Puthulbabu Stone crushers	Stone Chips and Aggregates	Sakrigali		
4	3-Aug-15	M/s. Bajrangee Stone works	Stone Chips and Aggregates	Sakrigali		
5	3-Aug-15	M/s. Mungerilal Stone Works	Stone Chips and Aggregates	Sakrigali		
6	6-Aug-15	M/s. CTC Stone crushers, Mahadevganj	Stone Chips and Aggregates	Sahibganj		
7	6-Aug-15	M/s. Yashraj Block Stone, Mr. Bajrangi Prasad Yadav	Stone Chips and Aggregates	Sahibganj		
8	6-Aug-15	Mr. Ram Savare Tiwari Stone crushers	Stone Chips and Aggregates	Sahibganj		
9	7-Aug-15	M/s. Mumtaz Stone, Mr. Mumtaz Ansari	Stone Chips and Aggregates	Sahibganj		
10	5-Aug-15	Mr. Rajesh Kumar Jaiswal Stone works	Stone Chips and Aggregates	Sahibganj		
11	7-Aug-15	M/s. F.A. Stone Works	Stone Chips and Aggregates	Sahibganj		
12	10-Aug-15	M/s. Yashraj Block Stone, Mr. Bajrangi Prasad Yadav	Stone Chips and Aggregates	Sahibganj		
13	4-Aug-15	M/s. Black Stone Works, Mr. Wahavavuddin	Stone Chips and Aggregates	Sahibganj		
14	10-Aug-15	M/s. Vaishnav Stone Works, Mr. Avadh Kishore Sinh	Stone Chips and Aggregates	Sahibganj		
15	10-Aug-15	M/s. Sarve Shri Sunny Stone Works, Mr. Amit Kumar	Stone Chips and Aggregates	Sahibganj		
16	11-Aug-15	Mr. Anil Yadav Stone works	Stone Chips and Aggregates	Sahibganj		
17	5-Aug-15	Mr. Mukesh Yadav, Munger	Stone Chips and Aggregates	Sakrigali		
18	4-Aug-15	M/s. Black Stone Works, Mr. Ved Prakash Khurania	Stone Chips and Aggregates	Sahibganj		
19	7-Aug-15	Mr. Pradhan Stone works	Stone Chips and Aggregates	Mirzachowki		
20	7-Aug-15	M/s. MKGN Stone Works	Stone Chips and Aggregates	Mirzachowki		
21	12-Aug-15	M/s. Mamatha Stone Works	Stone Chips and Aggregates	Mirzachowki		
22	13-Aug-15	M/s. Maa Bhavani Stone Works	Stone Chips and Aggregates	Mirzachowki		
23	13-Aug-15	M/s. Vaishnav Stone Works	Stone Chips and Aggregates	Mirzachowki		
24	7-Aug-15	M/s. Hindusthan Stone Works	Stone Chips and Aggregates	Mirzachowki		
25	7-Aug-15	M/s. Ashoka Engineering Stone works	Stone Chips and Aggregates	Mirzachowki		
26	8-Aug-15	M/s. Parvathy Stone works	Stone Chips and Aggregates	Mirzachowki		
27	12-Aug-15	M/s. RQS Silica Sand Mining Company.	Silica Sand Mining	Mangalhat		
28	12-Aug-15	M/s. SMC Silica Sand Mining Company.	Silica Sand Mining	Mangalhat		
29	21-Aug-15	M/s. Tirupati Pvt. Limited & Katihar Jute Mills	Textile Industry	Katihar		
30	24-Aug-15	M/s. TG Force India Pvt. Ltd.	Food Production	Katihar		
31	24-Aug-15	M/s. Purnea Mushrooms Pvt. Ltd.	Food Production	Katihar		

32	4-Aug-15	Sahibganj Railway Station	Stone Chips and Aggregates, Cement, Rice	Sahibganj
33	6-Aug-15	Sakrigali Railway Station	Stone Chips and Aggregates	Sakrigali
34	7-Aug-15	Mirzachowk Railway Station	Stone Chips and Aggregates	Mirzachowki
35	7-Aug-15	Bakudi Railway Station	Stone Chips and Aggregates	Bakudi
36	6-Aug-15	Barharwa Railway Station	Stone Chips and Aggregates	Barharwa
37	11-Aug-15	Kotalpukur Railway Station	Stone Chips and Aggregates	Kotalpukur
38	12-Aug-15	Pakur Railway Station	Stone Chips and Aggregates, Coal	Pakur
39	12-Aug-15	Rajmahal railway Station	Silica Sand	Rajmahal
40	20-Aug-15	Katihar Railway Station	Fertilizer, Cement	Katihar
41	13-Aug-15	Baghalpur Railway Station	Rice, Wheat, Fertilizer, Cement	Baghalpur
42	13-Aug-15	Kahalgaon Railway Station	Coal, Flyash	Kahalgaon
43	7-Aug-15	Pirpainti Railway Station	Coal	Pirpainti

The left-listed stations are major loading/ unloading points in the region. Hence the magnitude of loading recorded and origins/ destinations were collected for the past year from these railway stations to ascertain the demand specifically met by rail.

Source: Consultants' market survey, August-October 2015

Munger-Ballia Sector

No.	Commodity	Location of producers (origin)	Location of users (destination)	Address of the Firm
1	Cement	Naya Bhojpur	Buxar	Amar Cement Bhandar, Bhogpur, Buxar
2	Sand	Naya Bhojpur	Koilwar	
3	Stone Chips	Naya Bhojpur	Sasaram	
4	Stone Chips	Sasaram	Aara	Raju, Gitti, Kharsar, Majhin, Sasaram, Rohtas, Bihar
5	Stone Chips	Sasaram	Mohinya	
6	Stone Chips	Sasaram	Dinara	
7	Stone Chips	Sasaram	Buxar	
8	Rice	Dalmiyanagar	Buxar	Suraj, Ricemill, Dalmiyanagar, Rohtas, Bihar
9	Stone Chips	Sasaram	Aara	Dhanu, Gitti Machinery, Utpadan, Sasaram, Rohtas, Bihar
10	Stone Chips	Sasaram	Mohinya	
11	Stone Chips	Sasaram	Dinara	
12	Stone Chips	Sasaram	Buxar	
13	Rice	Dehri	Aara	Gupta G, Ricemill, Dalmiyanagar, Dihri, Rohtas, Bihar
14	Stone Chips	Sasaram	Aara	Arunidhi, Gitti, Kharsar Machine, Sasaram, Rohtas, Bihar

15	Stone Chips	Sasaram	Mohinya	Ajit, Gitti, Kharsar, Machine, Sasaram, Rohtas, Bihar
16	Stone Chips	Sasaram	Dinara	
17	Stone Chips	Sasaram	Buxar	
18	Stone Chips	Sasaram	Aara	
19	Stone Chips	Sasaram	Mohinya	
20	Stone Chips	Sasaram	Dinara	
21	Stone Chips	Sasaram	Buxar	Aditya, Gitti, Kharsar, Machine, Sasaram, Bihar
22	Stone Chips	Sasaram	Aara	
23	Stone Chips	Sasaram	Mohinya	
24	Stone Chips	Sasaram	Dinara	
25	Stone Chips	Sasaram	Buxar	
26	Stone Chips	Sasaram	Aara	
27	Stone Chips	Sasaram	Mohinya	Parinidhi, Gitti, Kharsar, Machine, Sasaram, Rohtas, Bihar
28	Stone Chips	Sasaram	Dinara	
29	Stone Chips	Sasaram	Buxar	
30	Stone Chips	Sasaram	Aara	
31	Stone Chips	Sasaram	Mohinya	Raju, Gitti, Kharsar, Sasaram, Rohtas, Bihar
32	Stone Chips	Sasaram	Dinara	
33	Stone Chips	Sasaram	Buxar	
34	Stone Chips	Sasaram	Aara	Jairam, Gitti, Kharsar, Machine, Sasaram, Rohtas, Bihar
35	Stone Chips	Sasaram	Mohinya	
36	Stone Chips	Sasaram	Dinara	
37	Stone Chips	Sasaram	Buxar	
38	Stone Chips	Sasaram	Aara	Jagnu, Gitti, Kharsar, Ricemill, Sasaram, Rohtas, Bihar
39	Stone Chips	Sasaram	Mohinya	
40	Stone Chips	Sasaram	Dinara	
41	Stone Chips	Sasaram	Buxar	
42	Cement	Bihiya	Aara	Ramco Aodhyogik Kendra, Bihiya
43	Cycle	Jagdishpur	Aara	Vijay Cycle Store, Jagdishpur, Bhogpur
44	Urea	Bhadsara	Aara	Amit Khad Bhandar, Bhadsara
45	Rice	Bhadsara	Aara	Maa Sharda Ricemill, Bhadsara, Jagdishpur, Bhogpur
46	Rice	Pero	BSFC (Aara)	Jai Maa Laxmi ji Rice Mill, Piro, Aara
47	Cement	Bihiya	Aara	Deepak Cement Store, Bihiya
48	Sand	Bihiya	Koilwar	
49	Stone Chips	Bihiya	Sasaram	
50	Rice	Hasawahdeh	BSFC (Aara)	Rajiv Kumar Singh, 9308249030
51	Rice	Kaithua	BSFC (Aara)	Maa Vaishno Devi Ricemill, Kaithua
52	Rice	Agiwa Bazar	BSFC (Aara)	Maa Vindhyaavaaisni Mini Ricemill, Agiwa Bazaar

53	Rice	Lehthan	BSFC (Aara)	Tiway ji, Ricemill, Lehthani
54	Iron Bar	Fatuwa	Odisa	Kaamdhenu Chad Company, Fatuwa, Patna
55	Iron Bar	Fatuwa	Kolkata	
56	Machine	Fatuwa	Kolkata	
57	Wire	Fatuwa	Purjia	Shri Bala ji Oil Company, Fatuwa, Patna
58	Iron Bar	Fatuwa	Odisa	Dada ji Company, fatuwa, Patna
59	Iron Bar	Didar Ganj (Fatuwa)	Odisa	Magadh Chad Company, Didarganj, Fatuwa, Patna
60	Iron Bar	Didar Ganj (Fatuwa)	Odisa	Vinay Iron Chad Company, Didar Ganj, Fatuwa, Patna, Bihar
61	Rice	Bihiya	BSFC (Aara)	Sunil Dukaan, Bahiya
62	Wheat	Bihiya	BSFC (Aara)	
63	Cement	New Bhojpur	Buxar	Kasim Cement Store, Bhogpur, Buxar
64	Sand	New Bhojpur	Koilwar	
65	Stone Chips	New Bhojpur	Sasaram	
66	Cement	Bihiya	Aara	Ramdhani Cement Store, Bihiya
67	Sand	Bihiya	Koilwar	
68	Stone Chips	Bihiya	Sasaram	
69	Cement	Bihiya	Aara	Maa Vindhyaavaaisni Cement Store, Bihiya
70	Sand	Bihiya	Koilwar	
71	Stone Chips	Bihiya	Sasaram	
72	Cement	Bihiya	Aara	Maa Jagdamba Cement Store, Bihiya
73	Sand	Bihiya	Koilwar	
74	Stone Chips	Bihiya	Sasaram	
75	Iron Bar	Fatuwa	Odisa	Dada ji Company, fatuwa, Patna
76	Cement	Bihiya	Aara	yadav Cement Store, Bihiya
77	Sand	Bihiya	Koilwar	
78	Stone Chips	Bihiya	Sasaram	
79	Cement	Bihiya	Buxar	Raju Cement Store, Naya Bhogpur
80	Sand	Bihiya	Koilwar	
81	Stone Chips	Bihiya	Sasaram	
82	Cement	Bihiya	Aara	Arun Cement Store, Bihiya
83	Sand	Bihiya	Koilwar	
84	Stone Chips	Bihiya	Sasaram	
85	Cement	Bihiya	Aara	Rajesh Gitti Store, Bihiya
86	Sand	Bihiya	Koilwar	
87	Stone Chips	Bihiya	Sasaram	
88	Cement	Bihiya	Buxar	Ojha, Cement Store, Naya Bhogpur
89	Sand	Bihiya	Koilwar	
90	Stone Chips	Bihiya	Sasaram	

91	Cement	Bihiya	Aara	Bansighar Cement Store, Bihiya
92	Sand	Bihiya	Koilwar	
93	Stone Chips	Bihiya	Sasaram	
94	Cement	Bihiya	Buxar	Shukla Building Material, KrishnaBrahma, Buxar
95	Sand	Bihiya	Koilwar	
96	Stone Chips	Bihiya	Sasaram	
97	Cement	Bihiya	Buxar	Jai Bhole Shankar, Naya Bhogpur, Buxar
98	Sand	Bihiya	Koilwar	
99	Stone Chips	Bihiya	Sasaram	
100	Cement	Bihiya	Buxar	Raja Cement Store, Naya Bhogpur
101	Sand	Bihiya	Koilwar	
102	Stone Chips	Bihiya	Sasaram	
103	Cement	Bihiya	Buxar	Maa Baalu Bhandar, Naya Bhogpur
104	Sand	Bihiya	Koilwar	
105	Stone Chips	Bihiya	Sasaram	
106	Cement	Bihiya	Buxar	Pandey Cement Store, Naya Store, Buxar
107	Sand	Bihiya	Koilwar	
108	Stone Chips	Bihiya	Sasaram	
109	Cement	Bihiya	Buxar	Mira, Cement Store, Naya Bhogpur
110	Sand	Bihiya	Koilwar	
111	Stone Chips	Bihiya	Sasaram	
112	Oils	Nalanda	Kolkata	Mohini Oils Mills Nalanda
113	Rice	Nalanda	Whole Nalanda District	Pawanpuri Ricemill, Nalanda
114	Rice	Nalanda	BFCS	Radhika Rice Mills, Silao, Nalanda, Bihar
115	Rice	Nalanda	BFCS	Ishan Chawal Utpadan, Nalanda, Bihar
116	Rice	Nalanda	BFCS	Budh Bihar Rice Mill, Nalanda, Bihar
117	Wheat	Nalanda	BFCS	Omprakash Roller Flour Mill, Nalanda, Bihar
118	Edibles Items	Nalanda	Sasaram	Maa shitlao-OM-Storage Pvt. Ltd. Nalanda
119	Edibles Items	Nalanda	Bhojpur	
120	Edibles Items	Nalanda	Buxar	
121	Edibles Items	Nalanda	Jahanabad	
122	Drinking Water	Nalanda	Delhi	Relent Enterprises pvt ltd, visthapit, Colony Nagdin-2, Rajgir, Nalanda
123	Potato	Nalanda	All Bihar	Metallite Food Processing Pvt Ltd, Islampur Road, Nalanda, Bihar
124	Bleaching Powder	Gaya	Kolkata	Madhu Chemicals, 1st Floor, Leela Palace, Near Tulsi market, gaya, Bihar
125	Iron	Gaya	Odisha	Vishnu Krishi Udyog, 4750 Saft, Gaya, Bihar
126	Tool Room	Gaya	Kolkata	Mital Bhai Construction 4750 Saft, Gaya, Bihar
127	Tool Room	Gaya	Odisha	
128	Plastic Granules	Gaya	Aara	Muskan Plastic, Nima Tola Choraha, Budhgaya, Gaya, Bihar

129	Plastic Granules	Gaya	Sasaram	
130	Plastic Granules	Gaya	Patna	
131	Plastic Granules	Gaya	Purjia	
132	Iron	Gaya	Odisa	Kavita Enterprises, Swaraj Puri Road, Gaya, Bihar
133	Iron	Gaya	Odisa	NTP Industries, Narayani Tubewell, 81, Tekari Road, Gaya, Bihar
134	Iron	Gaya	Kolkata	Alfa paints, Gurudwara Road, Gaya, Bihar
135	PVC Pipes			HI Diary & Agro Product Ltd, Boring Road, Opp. AM College, Adjacent to Petrol Pump
136	Processed Food			Amar pali Food Pvt. Ltd. Opp. Tara Mandir, Hazipur Industrial Area
137	Battery	Gaya	Kolkata	Infra power, ahmad ali house, Nagmitia Road, Gaya, Bihar
138	Ilaichi (Cardamom)	Gaya	Kolkata	Basanti Food Products, ramana road, gaya, Bihar
139	Electric Pipes	Bela	Patna	D.B. Electrical Industries, Plot No. 6, D-6, Industrial Estate, Bela, Phase-I, Muzzafar pur
140	Paper	Bela	Delhi	Sai Packing Factory, Bela, Muzzafarpur, Bihar
141	Tank	Bela	Delhi	Gangotari Adhyogik, Bela, Muzzafarpur, Bihar
142	Plastic	Bela	Uttar Pradesh	IP Industrial, Bela, Muzzafarpur, Bihar
143	Chicken Feed	Bela	Delhi	Khag Parsankaran Udyag, Bela, Muzzafarpur, Bihar
144	Tabacco	Bela	Kolkata	Archana Tambacco, Bela, Muzzaffarpur, Bihar
145	Pulses	Bela	Patna	Ripu Foods, Bela, Muzzaffar Pur, Bihar
146	Agriculture	Beka	Bokaro	Kishan Engineering Works, Bela, Muzzaffarnagar, Bihar
147	Pulses	Samastipur	Patna	Mahabir Enterprises, Samastipur, Bihar
148	Flour	Samastipur	Dhanbad	Natraj Industries, Harpur, Aloth, Samastipur, Bihar
149	Wheat	Samastipur	Kolkata	Shri bala ji Adhyogik, Samastipur, Bihar
150	Milk	Samastipur	All Bihar	Mitla Dugadh utpadak Sahkari Sanggh Ltd, Samastipur, Bihar
151	Chicken Feed	Samastipur	Dhanbad	Shivshakti Agro Industries, Samastipur, Bihar
152	Minery	Samastipur	Odisa	Mithla Engineering Adhyogik, Samastipur, Bihar
153	Thinner	Samastipur	Patna	Samrat Labrotaries, harpur, Samastipur, Bihar
154	Tank	Samastipur	Delhi	RS Industries, Samastipur, Bihar
155	Machinery	Darbhanga	Bokara	Vishwakarma Industries, bela, Darbhanga, Biah
156	Machinery	Darbhanga	Odisa	Shri Krishna Engineering, Naya Adhyogik Prangan, Bela, Darbhanga, Bihar
157	Pulses	Darbhanga	Patna	Pankaj Mini Daal Mill, bela, Darbhanga, Bihar
158	Aluminium	Darbhanga	Bokaro	Pooja Metal Industries, Bela, Darbhanga, Bihar
159	Pipe	Khadakpur (Patna)	Banaras	Mahashakti Pipe Industries, Saidpur Tola, Patna
160	Pipe	Khadakpur (Patna)	Assam	
161	Pipe	Khadakpur (Patna)	Guwahati	
162	Pipe	Khadakpur (Patna)	Ranchi	
163	Iron Bar	Fatuwa	Odisa	jai Jagdamba Chad Udyog, Fatuwa, Patna, Bihar
164	Iron Bar	Fatuwa	Kolkata	Shri Bala ji Iron, Fatuwa, Bihar
165	Besan	Fatuwa	Haldia	Shyam Besan, Fatuwa, Patna, Bihar
166	Iron Bar	Baikhatopur	Kolkata	

167	Stone Chips	Fatuwa	Sasaram	Raj Enterprises, Fatuwa, Patna
168	Chicken Feed	Samastipur	Patna	Massila Agro Industries, Samastipur, Bihar
169	Latex			Ficus Industries, D-18, Industrial Estate, Bela, Muzzaffarpur, Bihar
170	Urea	Bela	Delhi	Bajrang Rasayan Khad, Bela, Muzzaffarpur, Bihar
171	Plastic	Bela	Bhopal	Aditya Industrial, Plastic, Bela, Muzzaffarpur, Bihar
172	Plastic	Bela	Patna	Shri Krishna Product, Bela, Phase-I, Muzzaffarpur, Bihar
173	Mustard Oil	Bela	Gela (Muzzaffarpur)	Shiv Food Industries, N4, Industries State, Bela, Muzzaffarpur, Bihar
174	Besan	Bela	Gela (Muzzaffarpur)	
175	Flour	Bela	Gela (Muzzaffarpur)	
176	Electric	Bela	Bokaro	Malhotra Engineering Works Pvt. Ltd. Bela, Muzzaffarpur, Bihar
177	Bricks	Madhubani	Dhanbad	Chouthi Eet Bhatta, Bhawara, Madhubani, Bihar
178	Bricks	Madhubani	Dhanbad	Fatmi Eet Bhatta, Bhawara, Madhubani
179	Bricks	Madhubani	Dhanbad	Moti Eet Bhatta, Madhubani, Bihar
180	Bricks	Madhubani	Jhadiya	Umesh Paamnaami, Eet Bhatta, Salempur, Madhubani, Bihar
181	Bricks	Madhubani	Jhadiya	Madab Eet, Raghunathpur, Madhubani, Bihar
182	Bricks	Madhubani	Dhanbad	Dosti Eet Bhatta, Gibaspur, madhubani, Bihar
183	Bricks	Madhubani	Dhanbad	Bhawaki Eet Bhandar, Gibaspur, Madhubani, Bihar
184	Bricks	Madhubani	Dhanbad	Yakeshwar kumar paamnaami, yodharan, madhuabni, Bihar
185	Bricks	Madhubani	Jhadiya	Krishna Eet Bhatta, Yodhrana, Madhubani,, Bihar
186	Bricks	Madhubani	Dhanbad	Gold Eet Factory, Rati, Madhubani, Biah
187	Bricks	Madhubani	Dhanbad	Ghar Eet Bhandar, RATI, madhubani, Bihar
188	Flour	Begusarai	Patna	OM Food Procession Pvt. Ltd., Industries area, Deona, Begusarai, Bihar
189	Wood	Begusarai	Odisa	Padarath Saw Mill, Baruni Industrial area, Begusarai, Bihar
190	Flour	Begusarai	Patna	Jay shree industries, industrial area, Burani, begusarai, Bihar
191	Tiles	Begusarai	Rajasthan	Pawan tiles, Dewana Industrial area, Burani, Begusarai, Bihar
192	Coal	Begusarai	Dhanbad	Premier Adhyogik, Jauna Adhyogik Chetra, begusarai, Bihar
193	Tiles	Begusarai	Rajasthan	surya tiles industries, 4-IB, Industrial Area, Baruni, Begusarai, Bihar
194	Flour	Begusarai	Patna	Sarv Shri Om Food Product, Industrial Area Baruni, Begusarai, Bihar
195	Fodder	Begusarai	Patna	Gopal Sampurana Pashu Aahar, Industrial Area, Baurani, Begusarai, Bihar
196	Hydraulic Trailor	Begusarai	Bokaro	Shiv Shakti Engineering Works, Industrial area Dewana, Begusarai, Bihar
197	Industrial Machinery	Begusarai	Odisa	JP Engineering Adhyogik, Dewana, Begusarai, Bihar

Source: Consultants' market survey, August-October 2015

Ballia-Allahabad Sector

Sr No.	Date	Location	Organisation/ Company	Function	Agenda	Remarks
1	08.09.15	Ballia	FCI	Distribution of Grain	Surveyed Cargo Volumes, Freight Costs , O/D Pairs Percentage Split of Transport, Awareness / Advantages / Incentives of Water Transportation	Co-operative
2	06.09.15	Ballia	Indian Railways	Transportation of Cargo / Goods by Train	Surveyed Cargo Volumes, Freight Costs, O/D Pairs	Co-operative
3	10.09.15	Ballia	Mandi Samiti Ballia	Supplier of Fruits/ Vegetables	Surveyed Cargo Volumes, Freight Costs , O/D Pairs Percentage Split of Transport, Awareness / Advantages / Incentives of Water Transportation	Co-operative
4	12.09.15	Mau	FCI	Distribution of Grain	Surveyed Cargo Volumes, Freight Costs , O/D Pairs Percentage Split of Transport, Awareness / Advantages / Incentives of Water Transportation	Co-operative
5	14.09.15	Mau	Mandi Samiti Kopaganj	Supplier of Fruits/ Vegetables	Surveyed Cargo Volumes, Freight Costs , O/D Pairs Percentage Split of Transport, Awareness / Advantages / Incentives of Water Transportation	Co-operative
6	15.09.15	Mau	FCI	Distribution of Grain	Surveyed Cargo Volumes, Freight Costs , O/D Pairs Percentage Split of Transport, Awareness / Advantages / Incentives of Water Transportation	Co-operative
7	15.09.15	Mau	Indian Railways	Transportation of Cargo / Goods By Train	Surveyed Cargo Volumes, Freight Costs, O/D Pairs	Reluctant to give information
8	16.09.15	Azamgarh	Indian Railways	Transportation of Cargo / Goods by Train	Surveyed Cargo Volumes, Freight Costs, O/D Pairs	Cooperative
9	16.09.15	Azamgarh	FCI	Distribution of Grain	Surveyed Cargo Volumes, Freight Costs , O/D Pairs Percentage Split of Transport, Awareness / Advantages / Incentives of Water Transportation	Very cooperative
10	17.09.15	Jaunpur	Amba Cement	Producing of Cement	Surveyed Cargo Volumes, Freight Costs , O/D Pairs Percentage Split of Transport, Awareness / Advantages / Incentives of Water Transportation	Very cooperative
11	17.09.15	Jaunpur	Gangesh Cement	Producing of Cement	Surveyed Cargo Volumes, Freight Costs , O/D Pairs Percentage Split of Transport, Awareness / Advantages / Incentives of Water Transportation	Reluctant to give information
12	17.09.15	Jaunpur	Sale Tax Office	Collection of Revenues / Tax from Industries	Industries in District for Surveying Cargo Volumes, Freight Costs, O/D Pairs	Sale tax office informed about number of industries in district
13	17.09.15	Jaunpur	Abhinav Steel And Power Ltd	Manufacture of Steel / Thermal Plant	Surveyed Cargo Volumes, Freight Costs , O/D Pairs Percentage Split of Transport, Awareness / Advantages / Incentives of Water Transportation	Reluctant to give information, provided information about thermal plant but information on steel industry not given
14	17.09.15	Jaunpur	H.I.L Ltd C.K Birla Group Sathariya	Manufacturing of Roofsheets	Surveyed Cargo Volumes, Freight Costs , O/D Pairs Percentage Split of Transport, Awareness / Advantages / Incentives of Water Transportation	Very co-operative
15	17.09.15	Jaunpur	H.I.L Ltd C.K Birla Group Jhajjar	Manufacturing of Roofsheets	Surveyed Cargo Volumes, Freight Costs , O/D Pairs Percentage Split of Transport, Awareness / Advantages / Incentives of Water Transportation	Very co-operative
16	17.09.15	Jaunpur	H.I.L Ltd C.K Birla Group Faridabad	Manufacturing of Roofsheets	Surveyed Cargo Volumes, Freight Costs , O/D Pairs Percentage Split of Transport, Awareness / Advantages / Incentives of Water Transportation	Very co-operative
17	17.09.15	Kushinagar	Ramakant Transport	Transport /Supplier of Aggregates /Sand	Surveyed Cargo Volumes, Freight Costs , O/D Pairs Percentage Split of Transport, Awareness / Advantages / Incentives of Water Transportation	Co-operative

18	18.09.15	Jaunpur Afri	Balu Mandi	Supplier of Aggregates / Sand	Surveyed Cargo Volumes, Freight Costs , O/D Pairs Percentage Split of Transport, Awareness / Advantages / Incentives of Water Transportation	Co-operative
19	18.09.15	Jaunpur	FCI	Distribution of Grain	Surveyed Cargo Volumes, Freight Costs , O/D Pairs Percentage Split of Transport, Awareness / Advantages / Incentives of Water Transportation	Co-operative
20	18.09.15	Shahganj	Indian Railways	Transportation of Cargo / Goods by Train	Surveyed Cargo Volumes, Freight Costs , O/D Pairs Percentage Split of Transport, Awareness / Advantages / Incentives of Water Transportation	Co-operative
21	18.09.15	Shahganj	Agrasen Flour Mill	Producer of Agro (Wheat Flour)	Surveyed Cargo Volumes, Freight Costs , O/D Pairs Percentage Split of Transport, Awareness / Advantages / Incentives of Water Transportation	Co-operative
22	18.09.15	Shahganj	Moto Aahar Pvt Ltd	Producer of Agro (Wheat Flour)	Surveyed Cargo Volumes, Freight Costs , O/D Pairs Percentage Split of Transport, Awareness / Advantages / Incentives of Water Transportation	Co-operative
23	19.09.15	Sultanpur	Kisan Shahkari Chini Mill Ltd	Producer Of Sugar	Surveyed Cargo Volumes, Freight Costs , O/D Pairs Percentage Split of Transport, Awareness / Advantages / Incentives of Water Transportation	Co-operative
24	19.09.15	Kushinagar	FCI	Distribution of Grain	Surveyed Cargo Volumes, Freight Costs , O/D Pairs Percentage Split of Transport, Awareness / Advantages / Incentives of Water Transportation	Co-operative
25	19.09.15	Sultanpur	Sale Tax Office	Collection of Revenues / Tax from Industries	Industries in District for Surveying Cargo Volumes, Freight Costs, O/D Pairs	Sale tax office informed about number of industries in district
26	19.09.15	Sultanpur	Indian Railways	Transportation of Cargo / Goods By Train	Surveyed Cargo Volumes, Freight Costs, O/D Pairs	Co-operative
27	19.09.15	Pratapgarh	Sale Tax Office	Collection of Revenues / Tax from Industries	Industries in District for Surveying Cargo Volumes, Freight Costs, O/D Pairs	Sale tax office informed about number of industries in district
28	19.09.15	Kushinagar	Sale Tax Office	Collection of Revenues / Tax from Industries	Industries in District for Surveying Cargo Volumes, Freight Costs, O/D Pairs	Sale tax office informed about number of industries in district
29	19.09.15	Kushinagar	FCI	Distribution of Grain	Surveyed Cargo Volumes, Freight Costs , O/D Pairs Percentage Split of Transport, Awareness / Advantages / Incentives of Water Transportation	Co-operative
30	21.09.15	Allahabad (Naini)	Indian Railways	Transportation of Cargo / Goods By Train	Surveyed Cargo Volumes, Freight Costs, O/D Pairs	Co-operative
31	21.09.15	Gorakhpur	FCI	Distribution of Grain	Surveyed Cargo Volumes, Freight Costs , O/D Pairs Percentage Split of Transport, Awareness / Advantages / Incentives of Water Transportation	Co-operative
32	21.09.15	Gorakhpur	Narayan Roadlines	Transport /Supplier of Aggregates /Sand	Surveyed Cargo Volumes, Freight Costs , O/D Pairs Percentage Split of Transport, Awareness / Advantages / Incentives of Water Transportation	Co-operative
33	21.09.15	Gorakhpur	Sanjay Roadways	Transport /Supplier of Aggregates /Sand	Surveyed Cargo Volumes, Freight Costs , O/D Pairs Percentage Split of Transport, Awareness / Advantages / Incentives of Water Transportation	Problems in understanding questionnaire
34	21.09.15	Gorakhpur	Rajiv Janta Transport	Transport /Supplier of Aggregates /Sand	Surveyed Cargo Volumes, Freight Costs , O/D Pairs Percentage Split of Transport, Awareness / Advantages / Incentives of Water Transportation	Co-operative
35	21.09.15	Kushinagar	United Provinces Sugar Company Ltd	Sugar Producer	Surveyed Cargo Volumes, Freight Costs , O/D Pairs Percentage Split of Transport, Awareness / Advantages / Incentives of Water Transportation	Reluctant to give information
36	21.09.15	Kushinagar	Triveni Eng. And Industries Ltd	Sugar Producer	Surveyed Cargo Volumes, Freight Costs , O/D Pairs Percentage Split of Transport, Awareness / Advantages / Incentives of Water Transportation	Co-operative

37	21.09.15	Kushinagar	New Sugar Mills	Sugar Producer	Surveyed Cargo Volumes, Freight Costs , O/D Pairs Percentage Split of Transport, Awareness / Advantages / Incentives of Water Transportation	Co-operative
38	22.09.15	Allahabad (Naini) Michel Ganj	Indian Railways (Northern Railway Loco Siding)	Transportation of Cargo / Goods By Train	Surveyed Cargo Volumes, Freight Costs, O/D Pairs	Co-operative
39	22.09.15	Gorakhpur	Prashant Transport	Transport /Supplier of Aggregates /Sand	Surveyed Cargo Volumes, Freight Costs , O/D Pairs Percentage Split of Transport, Awareness / Advantages / Incentives of Water Transportation	Reluctant to give information
40	22.09.15	Gorakhpur	Jaiswal Transport	Transport /Supplier of Aggregates /Sand	Surveyed Cargo Volumes, Freight Costs , O/D Pairs Percentage Split of Transport, Awareness / Advantages / Incentives of Water Transportation	Reluctant to give information
41	22.09.15	Gorakhpur	U.P. Ballia Transport	Transport /Supplier of Aggregates /Sand	Surveyed Cargo Volumes, Freight Costs , O/D Pairs Percentage Split of Transport, Awareness / Advantages / Incentives of Water Transportation	Reluctant to give information
42	22.09.15	Gorakhpur	Sangam Transport	Transport /Supplier of Aggregates /Sand	Surveyed Cargo Volumes, Freight Costs , O/D Pairs Percentage Split of Transport, Awareness / Advantages / Incentives of Water Transportation	Problems in understanding questionnaire
43	22.09.15	Gorakhpur	Bengali Transport	Transport /Supplier of Aggregates /Sand	Surveyed Cargo Volumes, Freight Costs , O/D Pairs Percentage Split of Transport, Awareness / Advantages / Incentives of Water Transportation	Reluctant to give information
44	22.09.15	Allahabad Sargam	Sail (Warehouse)	Storage	Surveyed Cargo Volumes, Freight Costs , O/D Pairs Percentage Split of Transport, Awareness / Advantages / Incentives of Water Transportation	Very co-operative

Source: Consultants' market survey, August-October 2015

Annex 2: Roadside Interviews to identify Truck Loads

Interviews at Toll Plaza: Dulagarh

Trucks (no)	Cargo	Origin	Destination	Distance (km)	Volume (tons)
19	Container	Kolaghat	Haldia		18
11	Diesel	Alampur	Kolkata		12 kL
7	Chicken Granules	U.P.	Durgapur	475	20
7	Wire	Dulagad	Baruni	400	10
6	Iron	U.P.	Kashipur	1,000	20
5	Paper	Karnataka	Kolkata	2,200	20
5	Onion	Rajgarh	Dulagad	893	20
4	Onion	Madras	Dulagad		22
4	Gas	Kolkata	U.P.	1,000	12
3	Potatoes	Bihar	Howrah		20
3	Corn	Purniya	Durgapur	360	20
3	Rice	Purniya	Dulagad	475	15
2	Wire	Nagaland	Luberiya		18
1	Pulses	Chattisgarh	Durgi Para	850	20
1	Hindustan Surf	Haldia	Bihar		20
1	Chicken Granules	Banagarh	Dulagad	450	20
1	Container	Nagaland	Kanpur		13
1	Oil Tanker	Kolkata	U.P.	1,000	12
1	Corn	Purniya	Durgapur	360	12
1	Chemical Powder	Durgapur	AP	1,800	12
1	Crude Oil	Howrah	Barauni	575	10
1	Coca Cola	Hajipur	Kolkata		10
1	Corn	Purniya	Dulagad	475	8
1	Calisum	Ankleswer	Kasipur	2,100	6
1	Clothes	Kolkata	Patna	920	4
91	Total number of interviews				

Date: 22-07-2015

Interviews at Toll Plaza: Dankuni

Trucks (no)	Cargo	Origin	Destination	Distance (km)	Volume (tons)
10	Hero Bikes	Delhi	Kolkata	1,500	50 pc
7	Maida	Patna	Kolkata	750	20
7	Plastic Granules	Kanpur	Kolkata	1,700	15
5	Maruti Suzuki Cars	Delhi	Kolkata	1,550	8 cars
5	LPG	Muradabad	Paharpur	85	15
4	Hyundai Cars	Delhi	Kolkata	1,550	8
3	Iron	Danapur	Rajarhat	600	15
2	Chicken Granules	Patna	Mahnar	800	21
2	Paper	Bulandnagar	Durgapur	1,300	20
2	Wall Putty	Jabalpur	Kalyani	1,300	20
2	Maida	Lalganj	Kolkata	962	16
2	Crane Equipment	Bihar	Rajaghat	600	16
1	Paper	Bihar	Durgapur	1,300	20
1	Iron	Danapur	Kolkata	500	18
1	Iron	Danapur	Rajarhat	600	18
1	Cloth	Ahmedabad	Durgapur	2,200	16
1	Iron	Patna	Bengal	680	15
1	Iron	Patna	Rajarhat	600	15
1	Iron	Patna	Bangladesh Border	747	12
1	Shoe Materials	Delhi	Batanagar	1,650	11.5
59	Total number of interviews				

Date: 28-07-2015

Interviews at Toll Plaza: Mecheda

Trucks (no)	Cargo	Origin	Destination	Distance (km)	Volume (tons)
35	Indian Oil (empty)	Patna	Haldia		16
34	Fly Ash	Mecheda	Haldia		
32	Plastic Granules	Haldia	Muzzaparnagar	1,650	50
30	Edible Oil (empty)	Kolkata	Haldia		16
24	Coal	Haldia	Orissa	420	20
19	Container	Khidirpore	Haldia		
16	Cement (empty)	Haldia	Madhukunda		0
14	HP Gas	Haldia	Pharapur		
10	Container	Haldia	Uttrakhand		12
10	Fly Ash	Kolaghat	Haldia		
9	Container (empty)	Haldia	Khidirpore		0
7	Indian Oil	Haldia	Guwathi		34
7	Cement	Madhukunda	Haldia		20
7	Bharat Gas	Haldia	Kolkata		
5	Cement	Madhukunda	Haldia	326	20
4	Coal (empty)	Khragpur	Haldia		0
4	Indian Oil	Haldia	Debra (Kolkata)		
4	Steel Plates	Haldia	Dankuni		
3	Coal	Haldia	Khragpur		17
3	Fly Ash (empty)	Haldia	Kolaghat		0
3	Gas (empty)	Tirpai	Haldia		0
3	HP Gas (empty)	Kolkata	Haldia		0
2	Indian Oil (empty)	Jamshedpur	Haldia		16
1	Cement	Mirza	Haldia		20
1	Chemical Tanker	Haldia	Kandla		20
1	Indian Oil	Haldia	Guwathi		16.5
1	Indian Oil (empty)	Ara	Haldia		16
1	Gas (empty)	Kolaghat	Haldia		0
1	General (empty)	Kolaghat	Haldia		0
1	Indian Oil	Haldia	Kolkata		
292	Total number of interviews				

Date: 23-07-2015

Source: Consultants' Market Survey July – October 2015

Roadside interviews on NH-31 - Summary of commodities and tonnages, origins and destinations

Commodity Type	No of Vehicles				Origin	Destination	Average Tonnage				Total Tonnage
	LCV	2-Axle	3-Axle	MAV			LCV	2-Axle	3-Axle	MAV	
Coal				58	Guwahati	Odisha	4.5	9.4	13.5	18.0	1039.8
			23	29	Guwahati	Barh					835.4
Cement			94		Siliguri	Kolkata					1261.8
			47		Kolkata	Guwahati					630.9
Rice and Wheat		99	305		Kolkata	Siliguri					5032.9
	484	49	47	115	Kolkata	Guwahati					5342.2
	363				Guwahati	Siliguri					1624.2
				58	Haryana	Siliguri					1039.8
			94	87	Punjab	Guwahati					2821.6
				58	Delhi						1039.8
Crushed Stone and Flyash				130	UP/Allahabad	Siliguri	2339.7				
				58	Siliguri	Farakka	1039.8				
		25		14	Siliguri	Kolkata	493.0				
		87		Krishnagunj	Farakka	815.6					
Total											25,356.4

Roadside interviews on NH-31C - Summary of commodities and tonnages, origins and destinations

Commodity Type	No of Vehicles				Origin	Destination	Average Tonnage				Total Tons
	LCV	2-Axle	3-Axle	MAV			LCV	2-Axle	3-Axle	MAV	
Coal	3	5		2	Kolkata	4.5	9.4	13.5	18.0	84.7	
	7	14			Guwahati					Nepal	157.8
Cement			3		Kolkata					Nepal	43.2
		32			Guwahati						297.0
	7	14	1		Shillong						172.2
		5			Tripura						42.4
		5	7		Lanka (Assam)						143.1
Rice and Wheat	3				Guwahati					Nepal	15.3
			1		Kolkata						14.4
		5	1		Falakata						56.8
			1		Dalkhola	14.4					
Total										1041.4	

Source: Consultants' Market Survey July – October 2015

Annex 3: Commodities identified in Haldia-Farakka NW-1 sector (tons)

Commodity	Cargo volume 2014	Cargo volume 2015
Producer - Raniganj, W.B / User - Durgapur, Asansol, Kolkata, W.B by road		
Flour Wheat (Atta)	60,000	60,000
Flour (Maida)		40,000
Cattle Feed	20,000	20,000
Producer - Raniganj, W.B / User - Burdwan, W.B by Roads		
Iron & Steel	40,000	40,000
Producer - Mejia, Bankura, W.B / User - Kolkata/Shalimar, W.B by Road and Rail		
Cement	1,620,000	1,920,000
Producer - Madhukunda, Purulia, W.B. / User - All W.B. by road and rail - Sindri Cement Works, Dhanbad, Jharkhand / User - All Bihar by road and rail		
Cement	24,000,000	24,000,000
Producer - Dankuni, Mogra, W.B / User - Jorhat, Tezpur, Tinsukia, Assam		
Fertilizers	200	200
Producer - Kolkata, W.B / User - Jorhat, Tinsukia, Assam, Rajasthan		
Fertilizers	200	200
Producer, Haldia, W.B.- Gajraula, U.P / User - Jammu, Kashmir, Haldia		
Raw materials/Insecticides	2,000	2,000
Producer cum Supplier - Kolkata, W.B. / User - Bhagalpur, Bihar by Road		
Agro Equipment and Spares	1,000	1,000
Producer cum Supplier - Kolkata, W.B. / User - Patna, Bihar by Road		
Agro Equipment and Spares	6,000	6,000
Order Supplier, Nalhati, W.B/Pakur, Jharkhand / User - Chittagong, Bangladesh		
Aggregates	120,000	300,000
Inland Barge Operator - Haldia / Users - Budge budge, Haldia port area, Namkhana, Kolkata		
Petroleum Products	230,000	250,000
Shipping Line (River Transporters only) - Kolkata, Haldia / Users - Upper Assam at NW2		
ODCs (Gen/Stat/Trafos etc)	5,000	2013: 4,000
Project Logistics and Retail Transporter (FTL)- Kolkata, Haldia / User - Tezpur, Jogigopha, Biswanath		
Generator /Transformer, Metro Coaches, Reactor etc.)		2013: 1,000
ODC General Cargo	90,000	2013: 80,000
Forwarder and Terminal Operator : 5km dist within the port limit Location- Kolkata, Paradip Port, Bhubaneswar, Visakhapatnam Port, Kakinada Port, Krishnapatnam Port, Mangalore Port by road		
Coal	4530,000	5550,000
Iron Ore	1290,000	2330,000
Fertilizer	1960,000	2000,000
Food grains and Other Bulk	2010,000	1650,000
Ship Agents, Forwarder, Terminal operator - Kolkata, Haldia / User - Indian Sub-continent, Asean South		
Containers	500,000 TEU	500,000 TEU
Bulk	10,000,000	10,000,000
Project Cargo	1,000,000	1,000,000
Multimodal Integrated Supply Chain Solutions Provider : In Indian Coastal Waters by coastal vessels		
Containers	15,000 TEU	13,000 TEU
Customs Agent, Forwarder - NS dock / CFS, Kolkata / Users - Outside KoPT within 4 km		
Refractory Cargo	20,000	2013: 20,000
Shipping Agent - Kolkata		
Steel	30,000	2013: 20,000
General Cargo	80,000	2013: 50,000
Lime Stone	50,000	2013: 20,000
Coal	100,000	2013: 150,000
Trader - Kolkata / Users - Allahabad		
Lime Stone	3,000	3,000
Silica Sand	4,000	30,000

Annex 4: Farakka-Munger Survey Information

Table 1: Patna region district-wise commodity survey (roads)

SN	District (Origin)	Commodity	Destination
1	Patna	Steel Bars, Steel pipes, PVC Pipes, Dairy Products, Rice, Cement, Sand, Potato, Fruits, Paints, Stone chips etc.	Limited to state only
2	Bhojpur	Rice mills, Wheat, Cement, Sand, Dairy Products	UP and Bihar
3	Buxar	Rice mills, Wheat, Sand, Potatoes, Brick kilns	Bihar, West Bengal
4	Rohtas	Rice production, Wheat, Vegetable oil/ghee	Bihar, UP, West Bengal
5	Gaya	Tools, CI castings, PVC pipes, Electric appliances like starters, pump sets etc, Batteries, Dry Paints, Charcoal dust, Bleaching pwr etc.	Bihar, West Bengal
6	Nalanda	Flour mills, Drinking Water plants, Masoor dal, rice mills	Bihar, West Bengal
7	Darbhangha	Utensils, Daal Mills, Agriculture machinery, Rice cultivation, Potato, Wheat	Bihar, Nepal
8	Samastipur	Milk, Chicken feed, Agriculture machines, Wheat, Flour mills, Paint thinner, PVC storage tanks etc.	Bihar, West Bengal, Nepal
9	Mujafarpur	Biscuit, flour mills, rice mills, Steel bars, Chicken feed, PVC Pipes, Drinking Water, Kurkure / Chips Packaging, Dairy products	National Level via Patna
10	Begusarai	Carbon, Agricultural industries, Flour mills, Soya milk, Cattle feed, Tiles etc	Bihar, Nepal, West Bengal
11	Madhubani	Brick kilns	Bihar, Nepal
12	Chhapra	Sone river sand	Entire Northern Bihar
13	Siwan	Sand	Entire northern Bihar
14	Khagaria	Sand, Cement, Rice, Wheat, Flour Etc.	Entire northern Bihar

Note: Most of the places presumably charge by road only Rs 4/ton-km

Source: Consultants' Market Survey July – October 2015



Source: Consultants' Market Survey July – October 2015

Annex 5: Monthly Cargo Movements (tons)

Table 1: Stone chips loading operations at railway stations, 2014-15

Month	Pakur	Bakudi	Barharwa	Mirzachowk	Sahibganj (loading)	Sahibganj (unloading)
April	436,800	101,400	65,000	13,000	30,904	6,336
May	455,000	72,800	72,800	23,400	40,769	15,574
June	387,400	85,800	75,400	28,600	20,579	12,495
July	384,800	96,200	80,600	33,800	12,882	13,557
August	395,200	96,200	93,600	52,000	25,737	14,218
September	418,600	124,800	93,600	59,800	33,665	15,724
October	369,200	101,400	65,000	65,000	30,870	14,751
November	421,200	111,800	91,000	13,000	51,439	11,957
December	434,200	98,800	83,200	52,000	28,810	13,388
January	452,400	106,600	101,400	49,400	33,556	10,047
February	400,400	137,800	85,800	26,000	36,085	6,687
March	468,000	163,800	111,800	20,800	70,243	14,548
Total	5,023,200	1,297,400	1,019,200	436,800	415,539	149,282

Source: Consultants' market survey, August-October 2015

Table 2: Coal and other commodities loading operations at railway stations, 2014-15

Month	Pakur Thermal Coal	Pirpainti Thermal Coal	Mirzachowk Silica Sand
April	395,064	201,190	7,800
May	599,912	98,766	5,200
June	764,522	58,528	2,600
July	819,392	0	7,800
August	779,154	0	5,200
September	577,964	0	13,000
October	475,540	0	2,600
November	654,782	58,528	7,800
December	654,782	0	7,800
January	566,990	0	2,600
February	537,726	98,766	0
March	490,172	128,030	0
Total	7,316,000	643,808	62,400

Source: Consultants' market survey, August-October 2015

Table 3: Coal shipped to Super Thermal Power Plants

Month	Kahalgaon	GHTL	RTPP	GNTB
April	577,964	58,528	215,822	51,212
May	490,172	160,952	164,610	62,186
June	453,592	354,826	87,792	65,844
July	314,588	230,454	190,216	87,792
August	351,168	285,324	120,714	84,134
September	340,194	201,190	120,714	106,082
October	592,596	186,558	120,714	80,476
November	570,648	117,056	117,056	47,554
December	647,466	296,298	204,848	62,186
January	632,834	274,350	204,848	146,320
February	497,488	248,744	226,796	32,922
March	493,830	223,138	230,454	18,290
Total	5,962,540	2,637,418	2,004,584	844,998

Source: Consultants' market survey, August-October 2015

Table 4: Unloading of commodities at Bhagalpur railway station-2014-15

Month	Cement	Rice	Wheat	Fertilizer
April	20,800	5,200	2,600	0
May	28,600	5,200	5,200	5,200
June	26,000	10,400	5,200	5,200
July	10,400	7,800	13,000	5,200
August	15,600	13,000	15,600	5,200
September	20,800	18,200	5,200	5,200
October	15,600	13,000	7,800	2,600
November	13,000	15,600	10,400	2,600
December	15,600	7,800	5,200	5,200
January	26,000	7,800	2,600	2,600
February	18,200	5,200	7,800	0
March	31,200	7,800	7,800	2,600
Total	241,800	117,000	88,400	41,600

Source: Consultants' market survey, August-October 2015

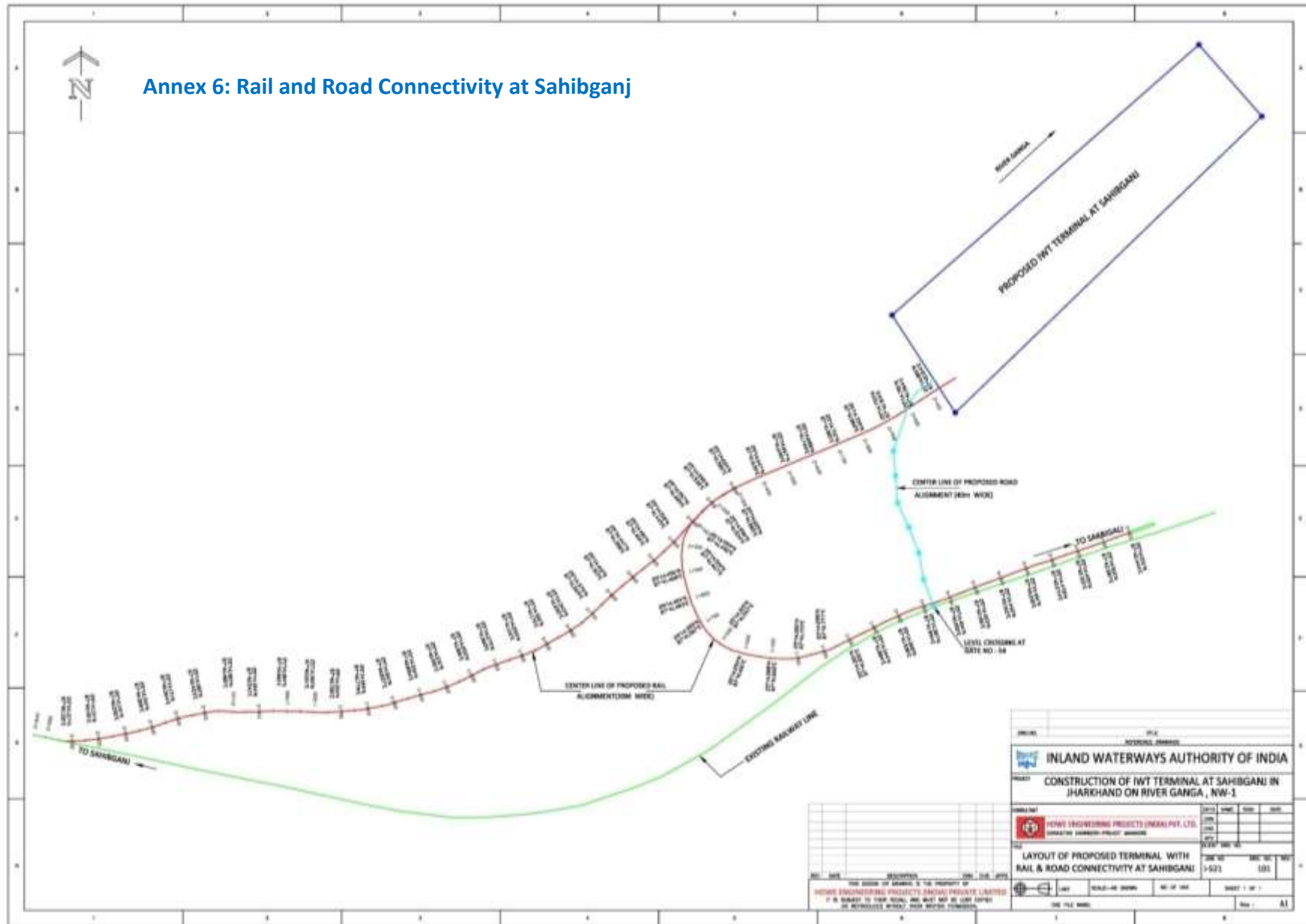

Annex 7: Railway Freight Charges for Class 150-Type Commodity

Source: www.fois.indianrail.gov.in

Distance		Rate per Ton		Distance		Rate per Ton
<i>from</i>	<i>to</i>	<i>from</i>		<i>to</i>	<i>from</i>	<i>from</i>
1	125	212.7	901	950		1330.1
126	150	259.4	951	1000		1396.1
151	175	290.7	1001	1100		1529.4
176	200	325.1	1101	1200		1663.1
201	225	356.9	1201	1300		1796.1
226	250	391.1	1301	1400		1928.4
251	275	425.3	1401	1500		2060.7
276	300	459.0	1501	1625		2189.1
301	325	491.0	1626	1750		2357.6
326	350	524.1	1751	1875		2424.3
351	375	557.3	1876	2000		2585.9
376	400	591.0	2001	2125		2612.0
401	425	625.1	2126	2250		2765.6
426	450	658.8	2251	2375		2790.6
451	475	692.0	2376	2500		2937.5
476	500	726.6	2501	2625		2983.7
501	550	795.2	2626	2750		3125.7
551	600	863.1	2751	2875		3170.0
601	650	930.5	2876	3000		3307.8
651	700	997.5	3001	3125		3350.4
701	750	1065.2	3126	3250		3484.5
751	800	1131.5	3251	3375		3526.2
801	850	1197.9	3376	3500		3656.7
851	900	1264.1				

Annex 8: Cost comparison of O/D pairs identified during through our market survey, calculated against potential O/D pairs channeled through Ghazipur

Commodity Type and Volume			Present O/D Details per Road Transport			Transport Case if shifted onto NW-1 (as per Transport Model)				Transport Case if shifted onto NW-1 (via Ghazipur)			
Commodity Type	Cargo Type	Volume 2014 [tons]	Origin	Destination	Total Cost [Rs/ton]	Entry Point NW1	Exit Point NW1	Total Cost on NW-1 [Rs/ton]	+/- Total Cost NW-1	Entry Point NW1	Exit Point NW1	Total Cost on NW-1 [Rs/ton]	+/- Total Cost NW-1
Wheat	General Cargo	42,000	Jaunpur	Manihari	2,168.4	Ramnagar MMT	Manihari	1,502.8	-30.7%	Ghazipur	Manihari	1,592.5	-26.6%
Textiles	Bagged	7,200	Kolkata GRT	Sultanpur	4,224.7	Kolkata GRT	Ramnagar MMT	3,257.2	-22.9%	Kolkata GRT	Ghazipur	3,405.0	-19.4%
General Cargo	Container	480,000	Kolkata	Birgunj (Nepal)	6,144.8	Kolkata GRT	Patna	4,824.8	-21.5%	Kolkata GRT	Ghazipur	6,416.3	4.4%
Project Cargo	Neo-Bulk	16,200	Kolkata GRT	Sultanpur	3,809.7	Kolkata GRT	Ramnagar MMT	3,143.2	-17.5%	Kolkata GRT	Ghazipur	3,256.5	-14.5%
Rice	Bagged	15,000	Naugarh	Kolkata	3,378.2	Ballia	Kolkata GRT	2,840.1	-15.9%	Ghazipur	Kolkata GRT	2,887.9	-14.5%
Food Grains	Bagged	6,000	Sultanpur	Kolkata	2,979.7	Ramnagar MMT	Kolkata GRT	2,531.3	-15.1%	Ghazipur	Kolkata GRT	2,588.9	-13.1%
Food	General Cargo	10,000	Sultanpur	Kolkata	2,979.7	Ramnagar MMT	Kolkata GRT	2,531.3	-15.1%	Ghazipur	Kolkata GRT	2,588.9	-13.1%
Steel	Neo-Bulk	216,000	Kolkata GRT	Sultanpur	3,228.7	Kolkata GRT	Ramnagar MMT	2,753.7	-14.7%	Kolkata GRT	Ghazipur	2,848.1	-11.8%
Cement	Bagged	100,000	Jaunpur	Patna	1,310.8	Ramnagar MMT	Patna	1,159.4	-11.6%	Ghazipur	Patna	1,342.6	2.4%
Food	General Cargo	21,900	Patna	Sultanpur	1,944.4	Patna	Ramnagar MMT	2,076.6	6.8%	Patna	Ghazipur	2,224.4	14.4%
Wheat	General Cargo	42,000	Jaunpur	Patna	1,041.1	Ramnagar MMT	Patna	1,141.5	9.6%	Ghazipur	Patna	1,231.2	18.3%
Wheat	General Cargo	40,000	Shahganj (UP)	Patna	1,549.0	Ballia	Patna	1,730.3	11.7%	Ghazipur	Patna	1,851.4	19.5%

Note: Yellow-headed columns show the commodities of the O/D pairs which have any potential to be deviated via the NW-1; grey-headed columns show origins and destinations of the commodities (all of which are presently trucked on roads) and their associated costs (Rs/ton); green-headed columns show the possible multi-modal deviation with terminals, their associated costs (Rs/ton) and the percentage of costs below (-) or above (+) road transport; blue-headed columns show the recalculated multi-modal deviation through a multi-modal terminal at Ghazipur, their associated costs (Rs/ton) and the percentage of costs below (-) or above (+) road transport.

Source: Consultants' market survey; recalculation by transport model

Annex 9: Potential Transhipment Cargo via Tribeni (MAC augmentation case, tons)

Transport Case						Transport Case if shifted to IWT		Cargo Traffic Forecast (tons)			
Cargo Type	Commodity Type	Origin	Destination	Distance [km]	Volume 2014 [tons]	Entry Point NW1	Exit Point NW1	2020	2025	2035	2045
Dry Bulk	Natural Aggregates	Naihati (WB)	Chittagong (Bangla)	820	7,500	Pakur	Sea/Other River	3,390	4,273	5,707	6,634
Dry Bulk	Natural Aggregates	Farakka	Haldia	509	90,000	Farakka	Haldia MMT	40,679	51,280	68,479	79,608
Dry bulk	Coal	Haldia	NTPC Farakka	424	168,096	Haldia MMT	Farakka			153,915	175,994
Dry Bulk	Coal	Sagar Island	Farakka	544	3,000,000	Sagar Island	Farakka	1,287,833	1,515,938	1,884,488	2,154,819
Dry bulk	Coal	Haldia	Pirpainti	625		Haldia MMT	Sahibganj MMT	41,195	32,956	26,365	21,092
Dry bulk	Coal	Haldia	Pirpainti	625		Haldia MMT	Sahibganj MMT	41,527	33,222	26,577	21,262
Dry bulk	Coal	Haldia	Pirpainti	625		Haldia MMT	Sahibganj MMT	45,846	36,677	29,341	23,473
Dry bulk	Coal	Haldia	Barh Super Therma	600	79,832	Haldia MMT	Sahibganj MMT		48,675	73,097	83,583
Dry bulk	Coal	Haldia	Vyas Nagar (Bihar)	742	3,944	Haldia MMT	Patna		2,405	3,611	4,129
Dry bulk	Coal	Haldia	Begusarai	806		Haldia MMT	Gemana		14,086	11,269	9,015
Dry bulk	Coal	Haldia	Krishna Silao (Bihar)	824	24,004	Haldia MMT	Patna		14,636	21,979	25,132
Dry bulk	Steel	Haldia	Raxaul (Bihar)	812	22,806	Haldia MMT	Patna			22,084	27,815
Dry bulk	Coal	Haldia	Kahaigaon	655		Haldia MMT	Kahaigaon		55,812	44,650	35,720
Dry bulk	Coal	Haldia	NTPC Kahaigaon	518	224,196	Haldia MMT	Kahaigaon	136,696	205,282	234,730	
Dry Bulk	Natural Aggregates	Pakur	Patna, Bihar	376	602,088	Pakur	Patna			458,117	532,564
Dry Bulk	Coal	Haldia HDC	Ballia	746	700	Haldia MMT	Ramnagar MMT	305	427	641	733
Dry Bulk	Coal	Haldia HDC	Ballia	746	800	Haldia MMT	Ramnagar MMT	353	488	733	838
Dry Bulk	Coal	Haldia HDC	Varanasi	773	1,000	Haldia MMT	Ramnagar MMT	442	610	916	1,047
Dry Bulk	Coal	Haldia HDC	Sultanpur	921	21,000	Haldia MMT	Ramnagar MMT	8,386	11,043	15,804	18,071
Dry bulk	Coal	Haldia	Buxar	1,089		Haldia MMT	Ghazipur	41,527	33,222	26,577	21,262
Dry Bulk	Coal	Haldia HDC	Partappargh	941	30,000	Haldia MMT	Ramnagar MMT	11,981	15,775	22,577	26,816
Dry bulk	Lime Stone	Kolkata	Allahabad	800	2,571	Kolkata GRT	Allahabad			1,574	1,830
Dry bulk	Sand	Kolkata	Allahabad	800	3,429	Kolkata GRT	Allahabad			2,098	2,439
Dry Bulk	Sand	Mangalhat	Kolkata	352	73,500	Raj Mahal	Kolkata GRT	41,878	55,925	65,013	
Dry Bulk	Iron Ore	Gaya	Kolkata	450	5	Patna	Kolkata GRT	1	2	2	
Dry bulk	Iron Ore	Barauni (Bihar)	Haldia	574	10,200	Gemana	Haldia MMT			7,740	8,228
Liquid Bulk	LPG Gas	Kolkata	Uttar Pradesh	1,000	7,200	Kolkata GRT	Allahabad			4,187	4,840
Bagged	Fertilizer	Kakinada Sea ports	Bhagalpur Railway	1,417	4,988	Haldia MMT	Kahaigaon		1,592	1,807	1,932
Bagged	Fertilizer	Paradip	Bhagalpur Railway	892	4,988	Haldia MMT	Kahaigaon		1,592	1,807	1,932
Bagged	Fertilizer	Vishakapatnam	Katihar Railway Sta	1,290	7,800	Haldia MMT	Manihari	2,490	2,825	3,020	
Bagged	Fertilizer	Vishakapatnam	Katihar Railway Sta	1,290	15,600	Haldia MMT	Manihari	4,979	5,651	6,041	
Bagged	Fertilizer	Vishakapatnam	Katihar Railway Sta	1,290	23,400	Haldia MMT	Manihari	7,469	8,476	9,061	
Bagged	Rice	Kolkata	Mau	708	250	Kolkata GRT	Ballia		140	192	204
Bagged	Bleaching Powder	Gaya	Kolkata	450	500	Patna	Kolkata GRT		146	160	169
Bagged	Flour	Lalgunj (UP)	Kolkata	960	3,200	Patna	Kolkata GRT		975	1,097	1,155
Bagged	Food Grains	Katihar	Kolkata	458	7,700	Manihari	Kolkata GRT		2,251	2,464	2,595
Bagged	Rice	Purnia (Bihar)	Dhulagah (WB)	475	12,000	Kahaigaon	Kolkata GRT			5,595	5,944
Bagged	Flour	Patna	Kolkata	620	16,800	Patna	Kolkata GRT			7,824	8,242
Bagged	Food Grains	Delhi	Haldia	1,661	10,521	Gemana	Haldia MMT			8,067	8,499
Bagged	Wheat	Fatuwa	Haldia	628	50,000	Patna	Haldia MMT	12,652	13,265	14,585	15,591
Bagged	Wheat	Samastipur	Kolkata	565	101,000	Kahaigaon	Kolkata GRT		32,027	36,336	38,844
Bagged	Wheat	BK Nagar	Kolkata	941	3,840	Ramnagar MMT	Kolkata GRT		2,731	4,123	4,407
Bagged	Plastic Granules	Kanpur (UP)	Kolkata	1,160	6,300	Ramnagar MMT	Kolkata GRT			4,253	5,511
Bagged	Food Grains	Sultanpur	Kolkata	830	6,000	Ramnagar MMT	Kolkata GRT			6,161	6,490
Bagged	Cement	Varanasi	Kolkata	681	8,000	Ramnagar MMT	Kolkata GRT		4,937	7,790	9,812
Bagged	Rice	Naugah (UP)	Kolkata	941	15,000	Ballia	Kolkata GRT		8,395	11,515	12,234
Bagged	Food Grains	Allahabad	Kolkata	790	12,000	Ramnagar MMT	Kolkata GRT			12,322	12,980
Bagged	Cement	Chunar	Kolkata	692	36,500	Ramnagar MMT	Kolkata GRT	15,862	22,524	35,542	44,766

continued on next page

continued from previous page

Transport Case						Transport Case if shifted to IWT		Cargo Traffic Forecast (tons)			
Cargo Type	Commodity Type	Origin	Destination	Distance (km)	Volume 2014 (tons)	Entry Point NW1	Exit Point NW1	2020	2025	2035	2045
Neo-bulk	Steel	Haldia	Raxaul (Bihar)	812	2,835	Haldia MMT	Patna			2,745	3,458
Neo-bulk	Paper	Kolkata	Varanasi	681	1,800	Kolkata GRT	Ramnagar MMT		1,100	1,733	2,183
Neo-bulk	Textiles	Kolkata	Sultanpur	830	7,200	Kolkata GRT	Ramnagar MMT	2,186	2,661	3,727	4,775
Neo-bulk	Textiles	Kolkata	Varanasi	681	10,950	Kolkata GRT	Ramnagar MMT	2,828	3,201	4,169	5,341
Neo-Bulk	Project Cargo	Kolkata	Sultanpur	830	16,200	Kolkata GRT	Ramnagar MMT			5,711	7,194
Neo-bulk	Textiles	Kolkata	Allahabad	790	12,000	Kolkata GRT	Ramnagar MMT	3,644	4,435	6,212	7,959
Neo-Bulk	Project Cargo	Kolkata	Pratagarh	849	18,250	Kolkata GRT	Ramnagar MMT		5,202	6,434	8,104
Neo-bulk	Textiles	Haldia HDC	Chunar	784	7,200	Haldia MMT	Ramnagar MMT	3,139	4,508	7,467	9,567
Neo-bulk	Textiles	Kolkata	Partaagarh	849	21,900	Kolkata GRT	Ramnagar MMT	6,650	8,094	11,337	14,525
Neo-bulk	Textiles	Haldia HDC	Jaunpur	683	15,800	Haldia MMT	Ramnagar MMT	11,146	20,095	42,102	53,942
Neo-Bulk	Project Cargo	Kolkata	Allahabad	790	162,000	Kolkata GRT	Ramnagar MMT		46,178	57,114	71,936
Neo-Bulk	Steel	Kolkata	Pratagarh	849	182,500	Kolkata GRT	Ramnagar MMT		66,121	88,067	110,922
Neo-Bulk	Steel	Kolkata	Sultanpur	830	216,000	Kolkata GRT	Ramnagar MMT		78,258	104,232	131,283
Neo-Bulk	Project Cargo	Gaya	Kolkata	400	500	Patna	Kolkata GRT		209	277	349
Neo-bulk	Textiles	Kathar	Hooghly, West Ben	436	1,313	Manihari	Kolkata GRT		612	869	1,114
Neo-bulk	Petroleum	Barauni (Bihar)	Haldia	574	2,646	Semaria	Haldia MMT		1,605	2,491	2,879
Neo-bulk	Petroleum	Garhara Goods Ma	Haldia	571	2,700	Semaria	Haldia MMT		1,638	2,542	2,938
Neo-bulk	Petroleum	Baad (UP)	Haldia	1,370	2,700	Semaria	Haldia MMT		1,638	2,542	2,938
Neo-bulk	Petroleum	Gazalabad (UP)	Haldia	1,480	5,400	Semaria	Haldia MMT		3,275	5,083	5,875
Neo-bulk	Petroleum	Baad (UP)	Haldia	1,370	10,800	Semaria	Haldia MMT		6,550	10,166	11,750
Neo-bulk	Petroleum	Garhara Goods Ma	Haldia	571	13,392	Semaria	Haldia MMT		8,122	12,606	14,571
Neo-bulk	Petroleum	Numaligarh Sliding	Haldia	1,442	13,446	Semaria	Haldia MMT		8,155	12,657	14,629
Neo-bulk	Petroleum	Indian Oil Refinary	Haldia	586	18,900	Semaria	Haldia MMT		11,463	17,791	20,563
Neo-bulk	Petroleum	Numaligarh Sliding	Haldia	1,442	24,138	Semaria	Haldia MMT		14,640	22,721	26,262
Neo-bulk	Petroleum	Barauni (Bihar)	Haldia	574	28,890	Semaria	Haldia MMT		17,522	27,194	31,433
Neo-Bulk	Project Cargo	Gaya	Kolkata	450	50,000	Patna	Kolkata GRT			27,745	34,946
Neo-Bulk	Steel	Balkhalapur	Kolkata	507	50,000	Patna	Kolkata GRT		21,414	28,436	35,816
Neo-Bulk	Steel	Fatuwa	Kolkata	536	50,300	Patna	Kolkata GRT	17,380	21,542	28,606	36,030
Neo-Bulk	Project Cargo	Fatuwa	Kolkata	536	80,000	Patna	Kolkata GRT	27,189	33,471	44,393	55,914
Neo-Bulk	Steel	Fatuwa	Kolkata	536	150,000	Patna	Kolkata GRT	51,829	64,242	85,307	107,447
Neo-bulk	Textiles	Varanasi	Kolkata	681	5,475	Ramnagar MMT	Kolkata GRT	1,414	1,600	2,084	2,670
Neo-bulk	Logs & Wood	Faizabad	Kolkata	878	3,120	Ramnagar MMT	Kolkata GRT			3,005	3,784
Neo-bulk	Statues	Chunar	Kolkata	692	40,000	Ramnagar MMT	Kolkata GRT	13,401	15,162	17,167	17,167
Container	Container	Kolkata	Birgunj (Nepal)	760	480,000	Kolkata GRT	Kalughat	215,186	319,900	559,602	729,307
Container	Container	Haldia	Varanasi	774	72,000	Haldia MMT	Ramnagar MMT			83,940	109,396
Container	Container	Kolkata	Varanasi	582	972,000	Kolkata GRT	Ramnagar MMT			1,133,195	1,476,848
General Cargo	Food	Kolkata	Varanasi	681	2,000	Kolkata GRT	Ramnagar MMT		520	557	586
General Cargo	Food	Kolkata	Allahabad	790	8,400	Kolkata GRT	Ramnagar MMT		3,231	3,912	4,121
General Cargo	Food	Purnea	Kolkata	494	58	Manihari	Kolkata GRT			19	20
Ro-Ro	Vehicles	Delhi	Kolkata	1,500	27,000	Allahabad	Kolkata GRT			21,042	28,052

Source: Consultants' market survey, August-October 2015; calculations by Consultants' transport model

Annexure 7: No prior EC required

This page has been intentionally left blank. Please turn over to next page.

No. F.No.14-9/2016-IA-III
Government of India
Ministry of Environment, Forest and Climate Change
(Impact Assessment Division)

Indira Paryavaran Bhawan
Jor Bagh Road, Aliganj
New Delhi-110003

Dated: 21st December, 2017.

OFFICE MEMORANDUM

Subject: Non-requirement of environment clearance for maintenance dredging in rivers for the purpose of navigation - regarding.

This has reference to your Office Memorandum IWT-11011/89/2016-IWT-(Vol.II) dated 7th December 2017 on the above mentioned subject.

2. The minutes of the meeting held under chairmanship of Hon'ble Minister, Road Transport & Highways, Shipping and Water Resources, River Development & Ganga Rejuvenation held on 24.10.2017 concluded that as per the extant legal position, no prior EC is required for maintenance dredging for navigational channel for Inland Waterways.

3. In view of the above the Ministry of Shipping may like to go ahead with the decision taken during the meeting held under chairmanship of Hon'ble Minister, Road Transport & Highways, Shipping held on 24.10.2017 subject to the implementation of the environmental safety measures as enclosed as annexure.

4. This issues with the approval of the competent authority.

Sharath Kumar Pallerla
Director

To

The Secretary,
Ministry of Shipping,
Parivahan Bhavan, 1, Parliament Street,
New Delhi - 110 001

Environmental safety measures to be implemented

- i. 'Consent to Establish' and 'Consent to Operate' shall be obtained from State Pollution Control Board under the Air (Prevention and Control of Pollution) Act, 1981 and the Water (Prevention and Control of Pollution) Act, 1974.
- ii. The project authority shall ensure that no rivers or tributaries are blocked due to any activities at the project site and free flow of water is maintained.
- iii. Shoreline shall not be disturbed due to dumping. Periodical study on shore line changes shall be conducted and mitigation carried out, if necessary.
- iv. Dredging shall not be carried out during the fish/turtle breeding seasons.
- v. All vessels used in the river will be fitted with noise control and animal exclusion devices so that aquatic life is not unduly disturbed.
- vi. Spillage of fuel / engine oil and lubricants from the construction site are a source of organic pollution which impacts aquatic life, particularly benthos. This shall be prevented by suitable precautions and also by providing necessary mechanisms to trap the spillage.
- vii. Construction waste including debris shall be disposed safely in the designated areas and in no case shall be disposed in the aquatic environment.
- viii. Vessels shall not discharge oil or oily water such as oily bilge water containing more than 15 ppm of oil.
- ix. The project authority shall ensure that water traffic does not impact the aquatic wildlife sanctuaries that fall along the stretch of the river.
- x. All vessels will also have to comply with 'zero discharge' standards to prevent solid or liquid waste from flowing into the river and affecting its biodiversity.
- xi. The dredging shall be carried by integrated and systematic planning by selective grid method by allowing migratory movement of Benthic fauna.
- xii. All required Noise and vibration control measures are to be adopted in Dredgers. Cutter section Dredgers should be avoided as much as possible which produces more noise and vibration. No Drilling and Blasting is to be carried out.
- xiii. Pre geo-tectonic studies has to be completed and the strata to be dredged is predetermined with complete data pertaining to hardness, compressive and tensile strengths.
- xiv. Dredger type and other strata loosening methods shall be preconceived.
- xv. Staggered dredging shall be carried based on turbidity monitoring to minimise the impact of turbidity.
- xvi. Threshold level of turbidity, which has a minimal effect on fauna, has to be predetermined and Dredging planned accordingly.
- xvii. Further silt screens needs to be used for minimising the spread of Turbidity.

- xviii. Disposal places of Dredged sediments needs to be predetermined, along the shore by assessment of suitability, which will not affect the shoreline (erosion) and also causing impacts during monsoon and flooding.
- xix. As much as possible, it shall not be disposed off in the river itself, and the site should be such that the dispersion is quicker by undertaking modelling studies.
- xx. Ballast water control and management measures shall be implemented.
- xxi. Waste and waste water reception facilities in Jetty shall be implemented.
- xxii. The Risk and Disaster management plan has been prepared in consonance with the manual of terminals and harbours issued by the Ministry of Environment and Forests dated 5th May 2010.
- xxiii. Standard Operating Procedures (SOP) and Emergency Response Plan (ERP) for onsite and offsite emergencies shall be prepared and implemented based on Hazard Identification and Risk Assessment to handle, process, store and transport of hazardous substances.
- xxiv. Oil spill contingency plan shall be prepared and part of DMP to tackle emergencies. The equipment and recovery of oil from a spill shall be assessed. Guidelines given in MARPOL and Shipping Acts for oil spill management shall be followed.
- xxv. No diversion of the natural course of the river shall be made without prior permission from the Ministry of Water resources.
- xxvi. All the erosion control measures shall be taken at water front facilities.
- xxvii. Necessary Air Pollution Control measures shall be taken during loading, unloading, handling, transport of the material at the berthing and water front facilities.
- xxviii. The Vessels shall comply the emission norms prescribed from time to time.
- xxix. All safety measures are to be implemented in coordination with the respective state government departments such as State Forest Department, Public Works Department, State Pollution Control Board etc.

21/12/17
Sharath Kumar Pallerla
Director

No. F.No.14-9/2016-IA-III
Government of India
Ministry of Environment, Forest and Climate Change
(Impact Assessment Division)

Indira Paryavaran Bhawan
Jor Bagh Road, Aliganj
New Delhi-110003

Dated: 21st December, 2017.

OFFICE MEMORANDUM

Subject: Non-requirement of environment clearance for maintenance dredging in rivers for the purpose of navigation - regarding.

This has reference to your Office Memorandum IWT-11011/89/2016-IWT-(Vol.II) dated 7th December 2017 on the above mentioned subject.

2. The minutes of the meeting held under chairmanship of Hon'ble Minister, Road Transport & Highways, Shipping and Water Resources, River Development & Ganga Rejuvenation held on 24.10.2017 concluded that as per the extant legal position, no prior EC is required for maintenance dredging for navigational channel for Inland Waterways.

3. In view of the above the Ministry of Shipping may like to go ahead with the decision taken during the meeting held under chairmanship of Hon'ble Minister, Road Transport & Highways, Shipping held on 24.10.2017 subject to the implementation of the environmental safety measures as enclosed as annexure.

4. This issues with the approval of the competent authority.

Sharath Kumar Pallerla
Director

To

The Secretary,
Ministry of Shipping,
Parivahan Bhavan, 1, Parliament Street,
New Delhi - 110 001

Environmental safety measures to be implemented

- i. 'Consent to Establish' and 'Consent to Operate' shall be obtained from State Pollution Control Board under the Air (Prevention and Control of Pollution) Act, 1981 and the Water (Prevention and Control of Pollution) Act, 1974.
- ii. The project authority shall ensure that no rivers or tributaries are blocked due to any activities at the project site and free flow of water is maintained.
- iii. Shoreline shall not be disturbed due to dumping. Periodical study on shore line changes shall be conducted and mitigation carried out, if necessary.
- iv. Dredging shall not be carried out during the fish/turtle breeding seasons.
- v. All vessels used in the river will be fitted with noise control and animal exclusion devices so that aquatic life is not unduly disturbed.
- vi. Spillage of fuel / engine oil and lubricants from the construction site are a source of organic pollution which impacts aquatic life, particularly benthos. This shall be prevented by suitable precautions and also by providing necessary mechanisms to trap the spillage.
- vii. Construction waste including debris shall be disposed safely in the designated areas and in no case shall be disposed in the aquatic environment.
- viii. Vessels shall not discharge oil or oily water such as oily bilge water containing more than 15 ppm of oil.
- ix. The project authority shall ensure that water traffic does not impact the aquatic wildlife sanctuaries that fall along the stretch of the river.
- x. All vessels will also have to comply with 'zero discharge' standards to prevent solid or liquid waste from flowing into the river and affecting its biodiversity.
- xi. The dredging shall be carried by integrated and systematic planning by selective grid method by allowing migratory movement of Benthic fauna.
- xii. All required Noise and vibration control measures are to be adopted in Dredgers. Cutter section Dredgers should be avoided as much as possible which produces more noise and vibration. No Drilling and Blasting is to be carried out.
- xiii. Pre geo-tectonic studies has to be completed and the strata to be dredged is predetermined with complete data pertaining to hardness, compressive and tensile strengths.
- xiv. Dredger type and other strata loosening methods shall be preconceived.
- xv. Staggered dredging shall be carried based on turbidity monitoring to minimise the impact of turbidity.
- xvi. Threshold level of turbidity, which has a minimal effect on fauna, has to be predetermined and Dredging planned accordingly.
- xvii. Further silt screens needs to be used for minimising the spread of Turbidity.

- xviii. Disposal places of Dredged sediments needs to be predetermined, along the shore by assessment of suitability, which will not affect the shoreline (erosion) and also causing impacts during monsoon and flooding.
- xix. As much as possible, it shall not be disposed off in the river itself, and the site should be such that the dispersion is quicker by undertaking modelling studies.
- xx. Ballast water control and management measures shall be implemented.
- xxi. Waste and waste water reception facilities in Jetty shall be implemented.
- xxii. The Risk and Disaster management plan has been prepared in consonance with the manual of terminals and harbours issued by the Ministry of Environment and Forests dated 5th May 2010.
- xxiii. Standard Operating Procedures (SOP) and Emergency Response Plan (ERP) for onsite and offsite emergencies shall be prepared and implemented based on Hazard Identification and Risk Assessment to handle, process, store and transport of hazardous substances.
- xxiv. Oil spill contingency plan shall be prepared and part of DMP to tackle emergencies. The equipment and recovery of oil from a spill shall be assessed. Guidelines given in MARPOL and Shipping Acts for oil spill management shall be followed.
- xxv. No diversion of the natural course of the river shall be made without prior permission from the Ministry of Water resources.
- xxvi. All the erosion control measures shall be taken at water front facilities.
- xxvii. Necessary Air Pollution Control measures shall be taken during loading, unloading, handling, transport of the material at the berthing and water front facilities.
- xxviii. The Vessels shall comply the emission norms prescribed from time to time.
- xxix. All safety measures are to be implemented in coordination with the respective state government departments such as State Forest Department, Public Works Department, State Pollution Control Board etc.

21/12/17
Sharath Kumar Pallerla
Director

F.No. 19-114/2017-IA.III
Government of India
Ministry of Environment, Forest and Climate Change

2226457h

Indira Paryavaran Bhawan,
Jor Bagh Road,
New Delhi-110003
Date: 19th December, 2017

OFFICE MEMORANDUM

Sub: Status of CRZ Clearance of proposed Inland Waterways Authority of India(IWAI)-regarding.

The undersigned is directed to refer to Ministry of Shipping, New Delhi D.O.No. IWT-11011/81/2015-IWT dated 26th October, 2017 regarding status of CRZ Clearance of proposed Inland Waterway Multi Model Terminal at Haldia, District Purbi Medinipur, West Bengal by M/s Inland Waterways Authority of India.

2. It is informed that the CRZ clearance has been issued to the project vide this Ministry's letter No. 11-14/2017-IA.III dated 06.11.2017(copy enclosed)

Encl: As above.

2and
(ARVIND NAUTIYAL)
DIRECTOR
Tel No. 24695340

Ministry of Shipping
[Shri Rajat Sachar, Adviser]
Transport Bhawan, 1st Parliament Street,
New Delhi-110001

Pl inform IWAI.



13/12/17

Dir (R)

F.No.11-14/2017-IA-III
Government of India
Ministry of Environment, Forest and Climate Change
(IA.III Section)

Indira Paryavaran Bhawan,
Jor Bagh Road, New Delhi - 110003
Dated: 06.11.2017

To,

The Director
M/s Inland Waterways Authority of India
District Purbi (East), Medinipur,
West Bengal

Sub: CRZ Clearance for Inland Waterway Terminal at Haldia, District Purbi (East), Medinipur, in West Bengal - reg.

Sir,

This has reference to your proposal IA/WB/MIS/62078/2017, dated 25.04.2017 received in this Ministry for CRZ Clearance in accordance with the provisions of the Coastal Regulation Zone (CRZ) Notification, 2011 issued under the Environment (Protection) Act, 1986.

2. The proposal has been considered by the Expert Appraisal Committee (EAC)-Infrastructure Development, Coastal Regulation Zone, Building / Construction and Miscellaneous projects, in 170th meeting held on May 11, 2017. The details of the project, as per the documents submitted by you and as informed during the aforesaid meetings of the EAC are noted as under:

- (i) The proposed project i.e construction of Inland Waterways Terminal (IWT) at Haldia is part of the 'Jal Marg Vikas Project' (JMVP) and is one of the project monitored by the Prime Ministers' Office under Pragati. The Public Investment Board on 06.03.2017 has recommended approval for the phase-I of the JMVP.
- (ii) The terminal will be developed within the Industrial Zone of Haldia Dock complex and will include jetty, berth, storage sheds, roads green area, administrative building, silos and other allied facilities. The proposed Halida terminal on National Waterways-1 (NW-1) will facilitate the bulk transportation of material and products through barges at lower coast and provide an opportunity for business and employment. Considering the potential of NW-1 transport mode IWAI has designed this terminal catering to the need of Halida Industrial belt. Inland water way transport is the most efficient and environment friendly mode of transportation, involving least CO2 emissions when compared to rail and road transport.
- (iii) The project is aimed at increasing transportation of goods through National Waterways-1 from Haldia to Allahabad and also augment the navigational capacity of NW-2, presently up to Bangladesh, thereby reducing the cost of transport on land. The present project proposal consists of 5 berths for handling of different cargos viz. coal, stone aggregates, fertilizers, fly ash, edible oil and POL amounting to a total capacity of 4.07 MTPA. This will be one of its first kind opening a gateway of inland water transport to the North-East region of the country.
- (iv) The area where the jetties would be constructed belongs to Kolkata Port Trust having proper draught. The activity is permissible in terms of para no. 4 (i) of CRZ Notification, 2011.
- (v) Project site partially falls under CRZ-IB, CRZ II and CRZ-IVB zone.

3and

- (vi) No mangroves or any other ecological entities are located in the project site.
- (vii) Direct employment of about 400-600 and indirect employment of about 4000-6000 are likely to be generated.
- (viii) CRZ map in scale of 1:4000 and 1:25000 covering 7 km radius of project site have been prepared by Institute of Remote Sensing, Anna University, Chennai.
- (ix) The West Bengal State Coastal Zone Management Authority has recommended the project for CRZ Clearance vide their letter No. 135/EN/T-II-4/018/2015 dated 24.01.2017.
- (x) Haldia was declared by CPCB a "Critically Polluted area (CPA's) by Advt. No. B-29012/ESS/CPA/2010. However, the moratorium has now been lifted vide MoEF office Memorandum N.J-11013/5/2010-IA dated 17.9.2013.
- (xi) The proposed terminal site from 500m-10km area around falls in Zone -IV high damage risk zone as per seismic zonal map of India and high cyclone risk zone.
- (xii) Hoogly river passes along the southern boundary of the terminal and the Haldi river is located about 9.5 km west of the proposed terminal.
- (xiii) Environmental impacts are of low to moderate significance. Environmental impacts are anticipated both during construction and operation phase. Major impacts anticipated are dust generation, occupational health & safety hazards, water quality degradation and impact on aquatic flora. However detailed management plan is prepared for the project which comprises of mitigation measures, preventive and environmental codes of practices measures. EMP if implemented will potentially reduce the anticipated impacts due to project.
- (xiv) The proposed investment cost will be about Rs 517.10 crores.

3. Based on the information submitted by you as at para no. 2 above and others and information made during the presentation before the EAC, the Ministry of Environment, Forest and Climate Change hereby accords CRZ Clearance to the above project viz '*Inland Waterway Terminal at Haldia, District Purbi (East), Medinipur, West Bengal*' under the provisions of the CRZ Notification, 2011 and amendments thereto and circulars issued thereon, and subject to the compliance of the following specific and general conditions as under:

PART A – SPECIFIC CONDITIONS:

- (i) All conditions/recommendations stipulated by the West Bengal Coastal Zone Management Authority (WBCZMA) vide its letter no. 135/EN/T-II-4/018/2015, dated 24.01.2017 shall strictly be complied with.
- (ii) Any other clearances, as may be applicable, under other rules/notifications/orders issued under the provisions of EIA Notification, 2006, shall be obtained, prior to commencement of the proposed activity.
- (iii) 'Consent to Establish' shall be obtained from State Pollution Control Board under the Air (Prevention and Control of Pollution) Act, 1981 and the Water (Prevention and Control of Pollution) Act, 1974.
- (iv) A 2% of the cost of the project shall be apportioned for marine and coastal biodiversity protection and conservation measures, to be spent by the project proponent towards fulfilling its Corporate Environmental Responsibility (CER) during the currency of the project. Proper record and account of measures taken should be maintained and should also be submitted to the CZMA every six months.

3and

- (v) The construction in CRZ areas shall strictly in accordance with the provisions of CRZ Notification, 2011 and as amended from time to time.
- (vi) The project shall be implemented in a manner such that it is consistent with the Government of India's mission on Clean Ganga and serves as role model for Inland Water Transport.
- (vii) The project proponent shall take necessary directives from National Ganga River Basin Authority before execution of the project.
- (viii) The project proponent shall commission a study on Gangetic Dolphin habitats and formulate road map for its conservation within a time bound manner not exceeding **two years**.
- (ix) The project proponent shall ensure that restoration plan for mudflat (in and around the vicinity of the project areas) is developed with specific focus on waders and other migratory species during the course of development of the project itself. Non-vegetated mudflats shall be maintained as it is and no mangrove afforestation should be undertaken on the same.
- (x) A robust scientific study on data of fish fauna available in the Ganges shall be carried out from an institute of national repute and report submitted within **one year** to the Regional Office of the Ministry and the Ganga Basin Authority.
- (xi) The project proponent shall ensure that implementation of the Oil Spill Contingency Plan is regularly monitored and observations documented and submitted to the concerned authority of the State Government.
- (xii) Surface water contamination shall be monitored periodically in order to prevent contamination of run-off water getting mixed of contaminated run-off with river. The monitoring results shall be submitted periodically to the State Pollution Control Board and the regional office of the Ministry.
- (xiii) In order to ensure that the fishing community are not disturbed during their course of fishing activity, the project proponent shall ensure that barge movement shall be restricted to channel area only and the speed of barges are efficiently regulated.
- (xiv) The project proponent shall provide arrangement for Fish Drying beds with prior consultation with the fishing community. In addition, the project proponent shall ensure rehabilitation and resettlement of the fishermen communities in the event the project impacts existing livelihood pattern of these communities.
- (xv) There shall be no disposal of solid or liquid wastes on the coastal area. Solid waste management shall be as per Solid Wastes Management Rules, 2016. A team comprising of members of the WBCZMA and others with expertise in the subject shall visit the project site periodically during the construction phase to supervise and suggest additional measures if desired.
- (xvi) Status of implementation of the specific and general conditions prescribed in the recommendations made by the West Bengal Coastal Zone Management Authority shall be submitted to all concerned agencies including regional office of the Ministry of Environment, Forest and Climate Change.

2019

- (xvii) There shall be no dressing or alteration of the sand dunes, natural features including landscape changes for beautification, recreation and other such purpose.
- (xviii) All waste (liquid and solid) arising from the proposed development will be disposed off as per the norms prescribed by Central/State Pollution Control Board. There shall not be any disposal of untreated effluent in to the sea/coastal water bodies.
- (xix) Soil and ground water samples shall be regularly collected from the project site and tested from an NABL accredited laboratory to ascertain that there are no threat to ground water quality by leaching of heavy metals and other toxic contaminants. In case, contamination is observed, immediate remedial action shall be undertaken and the concerned agency in the State Government shall be informed.
- (xx) Disposal of muck during construction phase should not create any adverse effect on the neighbouring communities and be disposed taking the necessary precautions for general safety and health aspects of people, only in approved sites with the approval of competent authority.
- (xxi) Any hazardous waste generated during construction phase, should be disposed off as per applicable rules and norms with necessary approvals of the State Pollution Control Board, as may be applicable.

PART – B: GENERAL CONDITIONS

- (i) Adequate provision for infrastructure facilities including water supply, fuel and sanitation must be ensured for construction workers during the construction phase of the project to avoid any damage to the environment.
- (ii) Full support shall be extended to the officers of this Ministry/Regional Office by the project proponent during inspection of the project for monitoring purposes by furnishing full details and action plan including action taken reports in respect of mitigation measures and other environmental protection activities.
- (iii) A six-monthly monitoring report shall be submitted by the project proponents to the Regional Office of this Ministry regarding the implementation of the stipulated conditions.
- (iv) The Ministry of Environment, Forest & Climate Change or any other competent authority may stipulate any additional conditions or modify the existing ones, if necessary in the interest of environment and the same shall be complied with.
- (v) The Ministry reserves the right to revoke this clearance if any of the conditions stipulated are not complied with to the satisfaction of the Ministry.
- (vi) In the event of a change in project profile or change in the implementation agency, a fresh reference shall be made to the Ministry.
- (vii) A copy of the clearance letter shall be marked to concerned Panchayat/ local NGO, if any, from whom any suggestion/ representation has been made received while processing the proposal.

2nd

- (viii) A copy of the CRZ Clearance letter shall also be displayed on the website of the concerned State Pollution Control Board. The Clearance letter shall also be displayed at the Regional Office, District Industries centre and Collector's Office/Tehsildar's Office for 30 days.
4. Concealing factual data or submission of false/fabricated data and failure to comply with any of the conditions mentioned above may result in withdrawal of this clearance and attract action under the provisions of Environment (Protection) Act, 1986.
 5. The above stipulations would be enforced among others under the provisions of the Water (Prevention and Control of Pollution) Act, 1974, the Air (Prevention and control of Pollution) Act, 1981, the Environment (Protection) Act, 1986, the Public Liability (Insurance) Act, 1991, the EIA Notification, 2006 and the CRZ Notification, 2011.
 6. In the case of any change(s) in the scope of the project, the project would require a fresh appraisal by this Ministry.
 7. The Ministry reserves the right to add additional safeguard measures subsequently, if found necessary, and to take action including revoking of the environment clearance under the provisions of the Environmental (Protection) Act, 1986, to ensure effective implementation of the suggested safeguard measures in a time bound and satisfactory manner.
 8. All other statutory clearances such as the approvals for storage of diesel from Chief Controller of Explosives, Fire Department, Civil Aviation Department, Forest (Conservation) Act, 1980 and Wildlife (Protection) Act, 1972 etc. shall be obtained, as applicable, by project proponents from the respective Competent Authorities.
 9. The project proponent should advertise in at least two local Newspapers widely circulated in the region, one of which shall be in the vernacular language informing that the project has been accorded CRZ Clearance and copies of clearance letters are available with the State Pollution Control Board (SPCB) and may also be seen on the website of the Ministry of Environment, Forest and Climate Change at <http://www.envfor.nic.in>. The advertisement should be made within Seven days from the date of receipt of the Clearance letter and a copy of the same should be forwarded to the Regional Office of this Ministry at Nagpur.
 10. This Clearance is subject to final order of the Hon'ble Supreme Court of India in the matter of Goa Foundation Vs Union of India in Writ Petition (Civil) No.460 of 2004 as may be applicable to this project.
 11. Any appeal against this clearance shall lie with the National Green Tribunal, if preferred, within a period of 30 days as prescribed under Section 16 of the National Green Tribunal Act, 2010.
 12. A copy of the clearance letter shall be sent by the proponent to concerned Panchayat, Zilla Parisad/Municipal Corporation, Urban Local Body and the Local NGO, if any, from whom suggestions/ representations, if any, were received while processing the proposal. The clearance letter shall also be put on the website of the company by the proponent.
 13. The proponent shall upload the status of compliance of the stipulated conditions, including results of monitored data on their website and shall update the same periodically. It shall simultaneously be sent to the Regional Office of MoEF&CC, the respective Zonal Office

Handwritten signature

of CPCB and the SPCB. The criteria pollutant levels namely SPM, RSPM, SO₂, NO_x (ambient levels as well as stack emissions) or critical sectoral parameters, indicated for the project shall be monitored and displayed at a convenient location near the main gate of the company in the public domain.

14. The environmental statement for each financial year ending 31st March in Form-V as is mandated to be submitted by the project proponent to the concerned State Pollution Control Board as prescribed under the Environment (Protection) Rules, 1986, as amended subsequently, shall also be put on the website of the company along with the status of compliance of conditions and shall also be sent to the respective Regional Office of the Ministry by e-mail.

(Arvind Nautiyal)
Director

Copy to:

1. The Secretary, Department of Environment Forests, Science and Technology, Government of West Bengal State Council of Science & Technology Bikash Bhawan, North Block (4th Floor) Salt Lake, Sector III Kolkata - 700091
2. The Chairman, West Bengal State Council of Science & Technology Bikash Bhawan, North Block (4th Floor) Salt Lake, Sector III Kolkata - 700091
3. The Chairman, CPCB, Parivesh Bhawan, CBD-cum-Office Complex, East Arjun Nagar, Delhi - 110032
4. The Member Secretary, West Bengal Pollution Control Board, Paribesh Bhavan, 10A, Block-L.A., Sector III, Salt Lake City, Calcutta - 700 098
5. The APCCF (C), MoEF&CC Regional Office (EZ), A/3, Chandersekharpur, Bhubaneswar - 751023
6. Guard File.
7. Monitoring Cell.

(Arvind Nautiyal)
Director

Annexure 8: Conversion rate of 1 TEU

This page has been intentionally left blank. Please turn over to next page.

(Published in Part - III Section 4 of the Gazette of India, Extraordinary)
TARIFF AUTHORITY FOR MAJOR PORTS

G.No. 84

New Delhi,

1 March 2017

NOTIFICATION

In exercise of the powers conferred under Sections 48 and 50 of the Major Port Trusts Act, 1963 (38 of 1963), the Tariff Authority for Major Ports hereby disposes of the proposal received from New Mangalore Port Trust (NMPT) for fixation of reference tariff for development of container terminal and for handling other cargo at berth no.8 on Public Private Partnership (PPP) mode at NMPT under the revised guidelines for Determination of Tariff for Projects at Major Ports, 2013, which were notified vide Notification No.TAMP/18/2013-Misc. dated 30 September 2013 vide Gazette No. 254, as in the Order appended hereto.

(T.S. Balasubramanian)
Member (Finance)

Tariff Authority for Major Ports
No. TAMP/56/2016–NMPT

New Mangalore Port Trust (NMPT)

Applicant

QUORUM

- (i). Shri. T.S. Balasubramanian, Member (Finance)
- (ii). Shri. Rajat Sachar, Member (Economic)

O R D E R

(Passed on this 4th day of January 2017)

This case relates to the proposal received from the New Mangalore Port Trust (NMPT) for fixation of reference tariff for development of container terminal and for handling other cargo at berth no.8 on Public Private Partnership (PPP) mode at NMPT.

2. The main submissions made by the NMPT in the proposal are summarized below:

- (i). (a). The proposed project is about Development of Container Terminal of Berth No. 8 for at the NMPT. A Detailed Project Report (DPR) for the project has been carried out on the basis of traffic analysis and technical assessment.
- (b). Berth No.8 is a deep draft and multipurpose berth operated by the Port for handling various commodities like dry bulk and general cargo. The berth has a length of 350 metres, width of 35 metres, draft of 14 metres and depth of 15.1 metres.
- (c). It is estimated that the expected traffic for Container Cargo in the first year shall be 90,000 TEUs, while that for Other Clean Cargo shall be 0.25 MTPA. Based on these expected traffic, the share of cargo between Container Cargo and Other Clean Cargo comes to 84.375%: 15.625%.

(ii). **Estimation of Optimal Capacity:**

- (a). Optimal capacity of the terminal has been determined taking into consideration various components of the facility that will be required to be created, equipment and plant and machinery to be provided, productivity levels and utilization levels, as per the norms prescribed. Tariff shall be prescribed with reference to the optimal capacity of the terminal irrespective of any traffic forecast.

The optimal capacity of the terminal is reckoned as the lower value of the optimal quay capacity and optimal yard capacity, which has been calculated separately for Container Cargo and Other Clean Cargo.

(b). **Container Cargo:**

Generally, the handling capacity of Container Cargo terminal is calculated in terms of number of Twenty-Foot Equivalent containers (TEUs). However, to convert the same in tonnes, a factor of 15 tonnes per TEU has been used. This factor was derived from the data on Commodity-wise Traffic Handled at Major Ports provided in the Update on Indian Port Sector published on 31.03.2016 by Transport Research Wing, Ministry of Road Transport & Highways, Government of India.

(i). **Estimation of Optimal Quay Capacity:**

For the total berth length of 350 m, as per norms, three gantry cranes are required. However, due to minimal traffic envisaged,

Annexure 9: Hydrography Chart between the proposed IWAJ Terminal and the Haldia Port Lock Gate

This page has been intentionally left blank. Please turn over to next page.

88° 4' 48" E

88° 7' 12" E

88° 9' 36" E

88° 12' 0" E

22° 4' 48" N

22° 4' 48" N

22° 2' 24" N

22° 2' 24" N

Predicted Tides

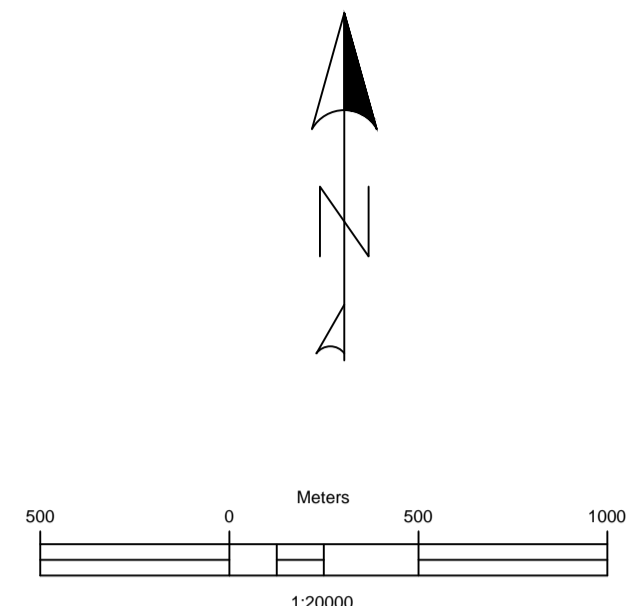
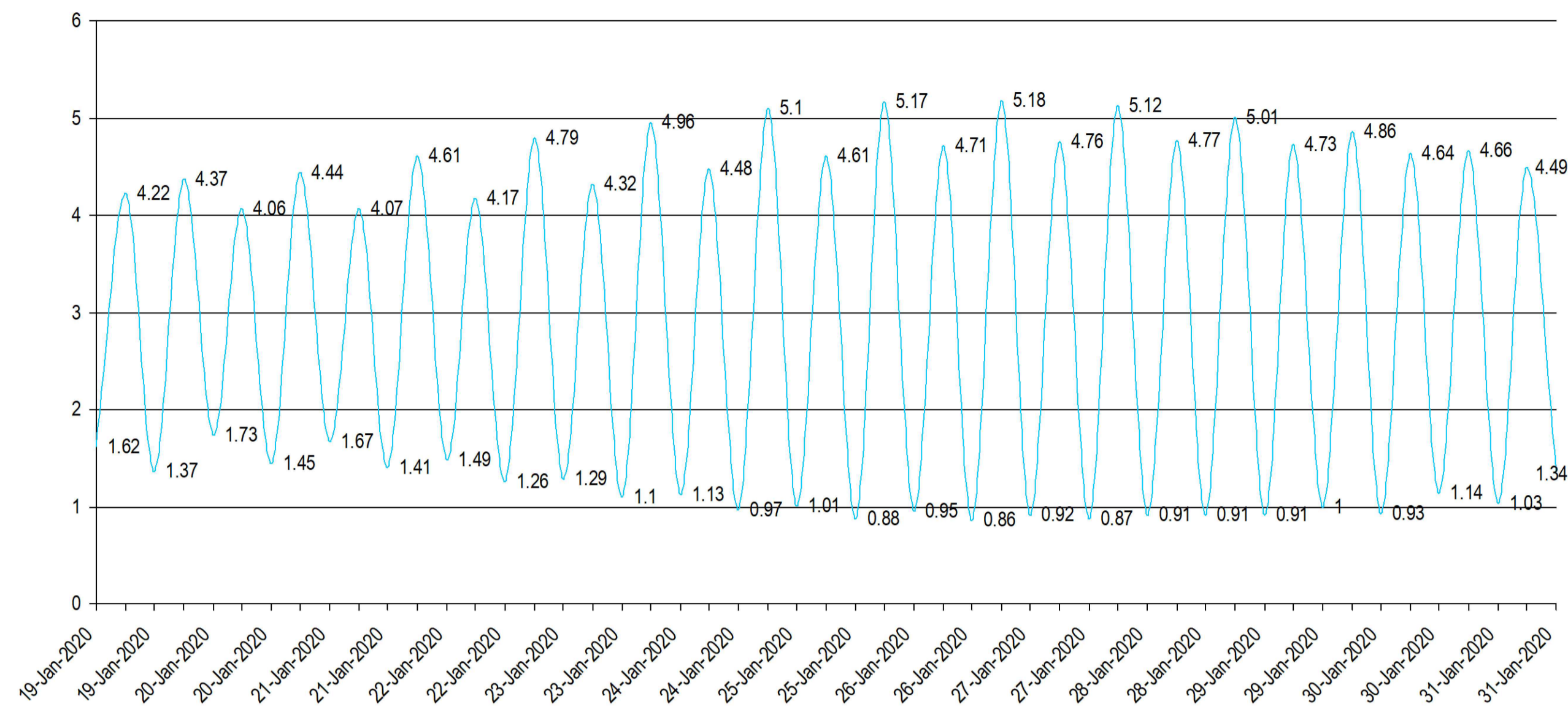

REFERENCES

SL #	DESCRIPTION	SYMBOL
1	River High Bank	
2	Mooring Buoy	
3	Sand Chur/Shallow areas	
4	Non-Metal Road	
5	Pipe Lines	
6	Anchoring Area	
7	Firm Island	
8	Ditches	
9	Vessel Anchored	
10	Fishing Nets	
11	Buoy with navigational lights	

CONTOUR REFERENCES

1	<0m	
2	0m to 2m	
3	2m to 3m	
4	3m to 4m	
5	>4m	

GOVT. OF INDIA
INLAND WATERWAYS AUTHORITY OF INDIA

NATIONAL WATERWAY NO. - 1
RIVER HOOGHLY
MAP SHOWING DEPTH BANDS OF THE SURVEYED AREA OF BALLARI CHANNEL, HALDIA
PERIOD OF SURVEY - 19/01/2020 TO 31/01/2020

- Soundings are in meter and decimeter.
- Sounding line interval - 25m, Sounding spacing ≈ .64m
- Depths are reduced to sounding datum of Haldia Tidal observatory which is 2.82m below M.S.L. and as per predicted tide book published by Survey of India
- Horizontal Datum - WGS 84, Projected in UTM (North) Zone - 45
- Sounding collected by single beam echosounder and DGPS beacon receiver.
- Vessel utilised - S.L. Koel.
- Surveyed by - Sh. Gopeswar Kundu, J.H.S.; Sh. Goutam Halder, J.H.S.
- River Flow - Bidirectional

Sheet No.: 01 Scale: 1:20000 Date: 7 February 2020

88° 4' 48" E

88° 7' 12" E

88° 9' 36" E

88° 12' 0" E

Annexure 10: Approach channel for Haldia MMT

This page has been intentionally left blank. Please turn over to next page.

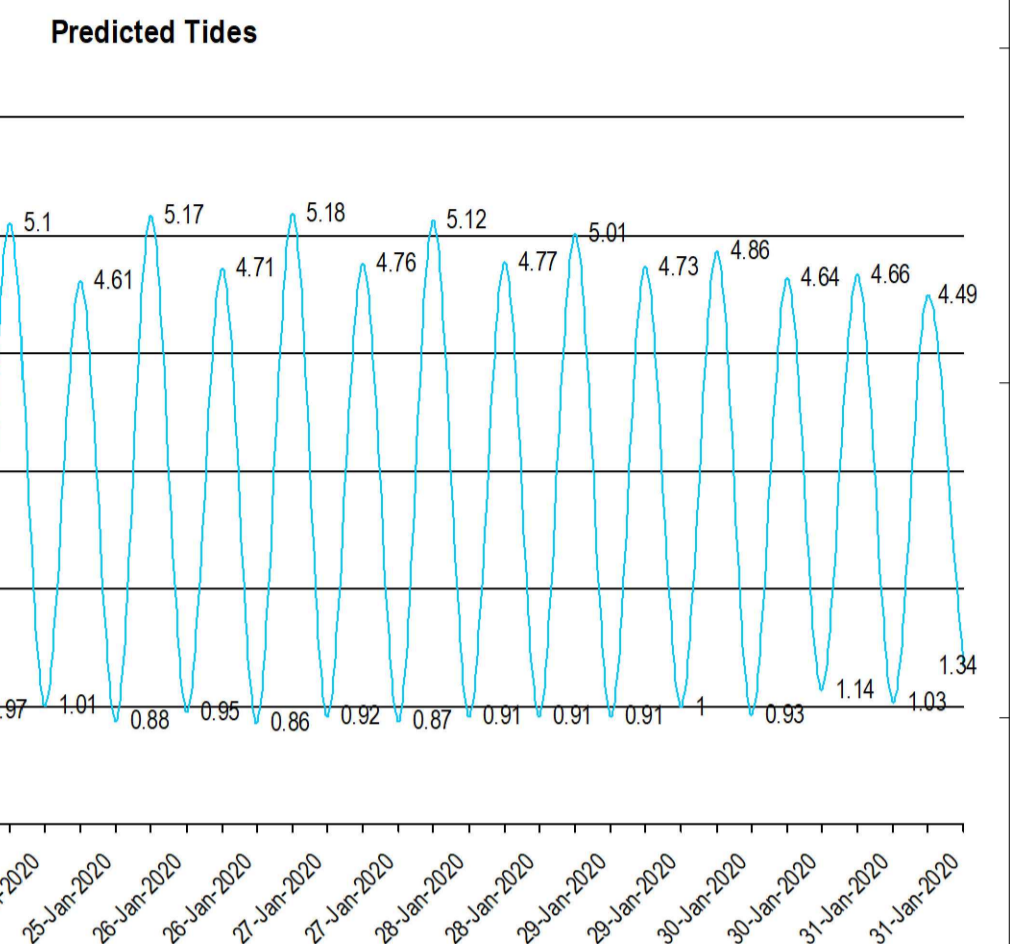
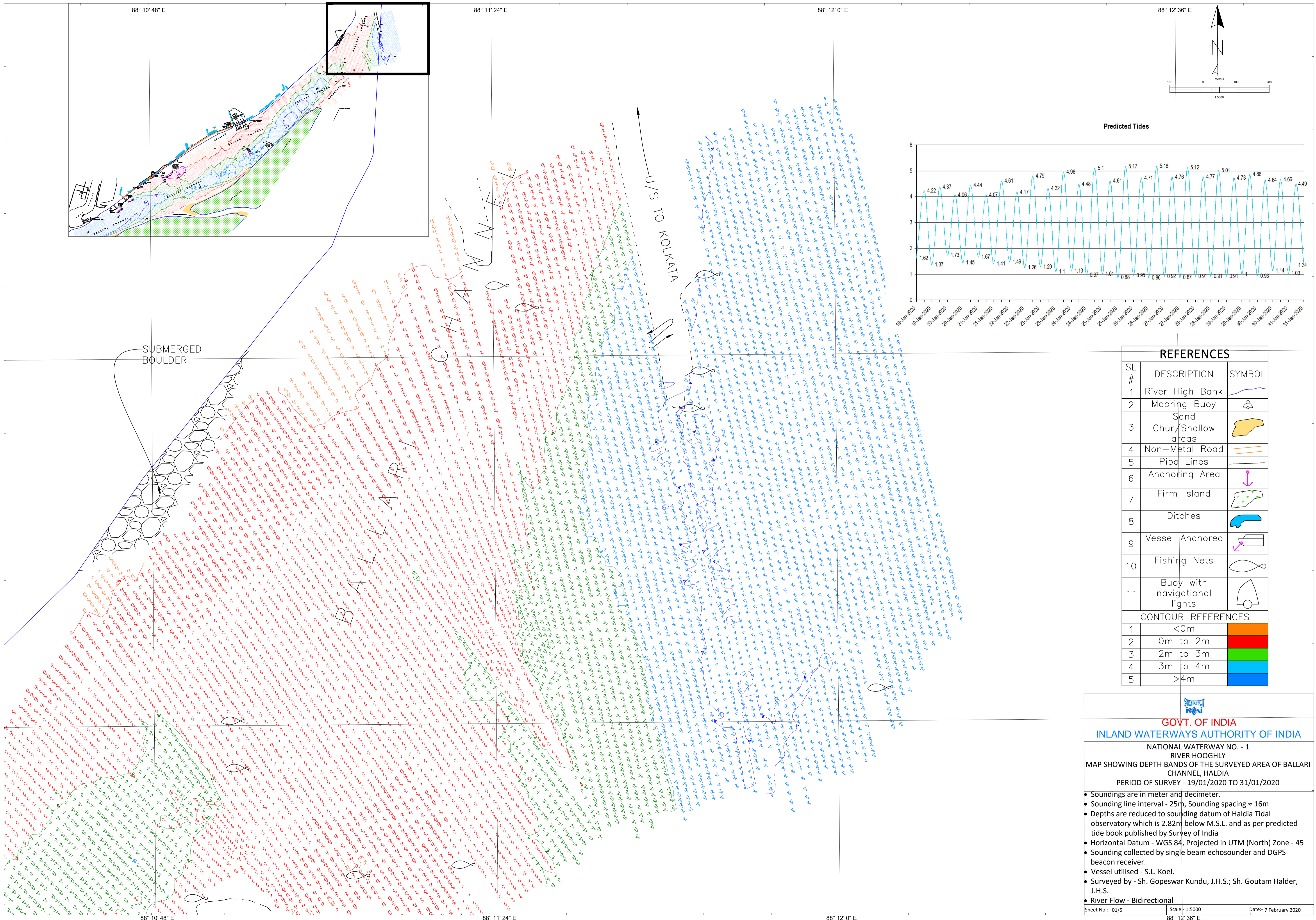

REFERENCES		
SL #	DESCRIPTION	SYMBOL
1	River High Bank	
2	Mooring Buoy	
3	Sand Chur/Shallow areas	
4	Non-Metal Road	
5	Pipe Lines	
6	Anchoring Area	
7	Firm Island	
8	Ditches	
9	Vessel Anchored	
10	Fishing Nets	
11	Buoy with navigational lights	

CONTOUR REFERENCES		
SL #	DEPTH	COLOR
1	<0m	Orange
2	0m to 2m	Red
3	2m to 3m	Green
4	3m to 4m	Light Blue
5	>4m	Dark Blue

GOVT. OF INDIA
INLAND WATERWAYS AUTHORITY OF INDIA
 NATIONAL WATERWAY NO. - 1
 RIVER HOOGHLY
 MAP SHOWING DEPTH BANDS OF THE SURVEYED AREA OF BALLARI CHANNEL, HALDIA
 PERIOD OF SURVEY - 19/01/2020 TO 31/01/2020

- Soundings are in meter and decimeter.
- Sounding line interval - 25m, Sounding spacing ≈ 16m
- Depths are reduced to sounding datum of Haldia Tidal observatory which is 2.82m below M.S.L. and as per predicted tide book published by Survey of India
- Horizontal Datum - WGS 84, Projected in UTM (North) Zone - 45
- Sounding collected by single beam echosounder and DGPS beacon receiver.
- Vessel utilised - S.L. Koel.
- Surveyed by - Sh. Gopeswar Kundu, J.H.S.; Sh. Goutam Halder, J.H.S.
- River Flow - Bidirectional

Sheet No.: 01/5 Scale: 1:5000 Date: 7 February 2020
 88° 12' 36" E

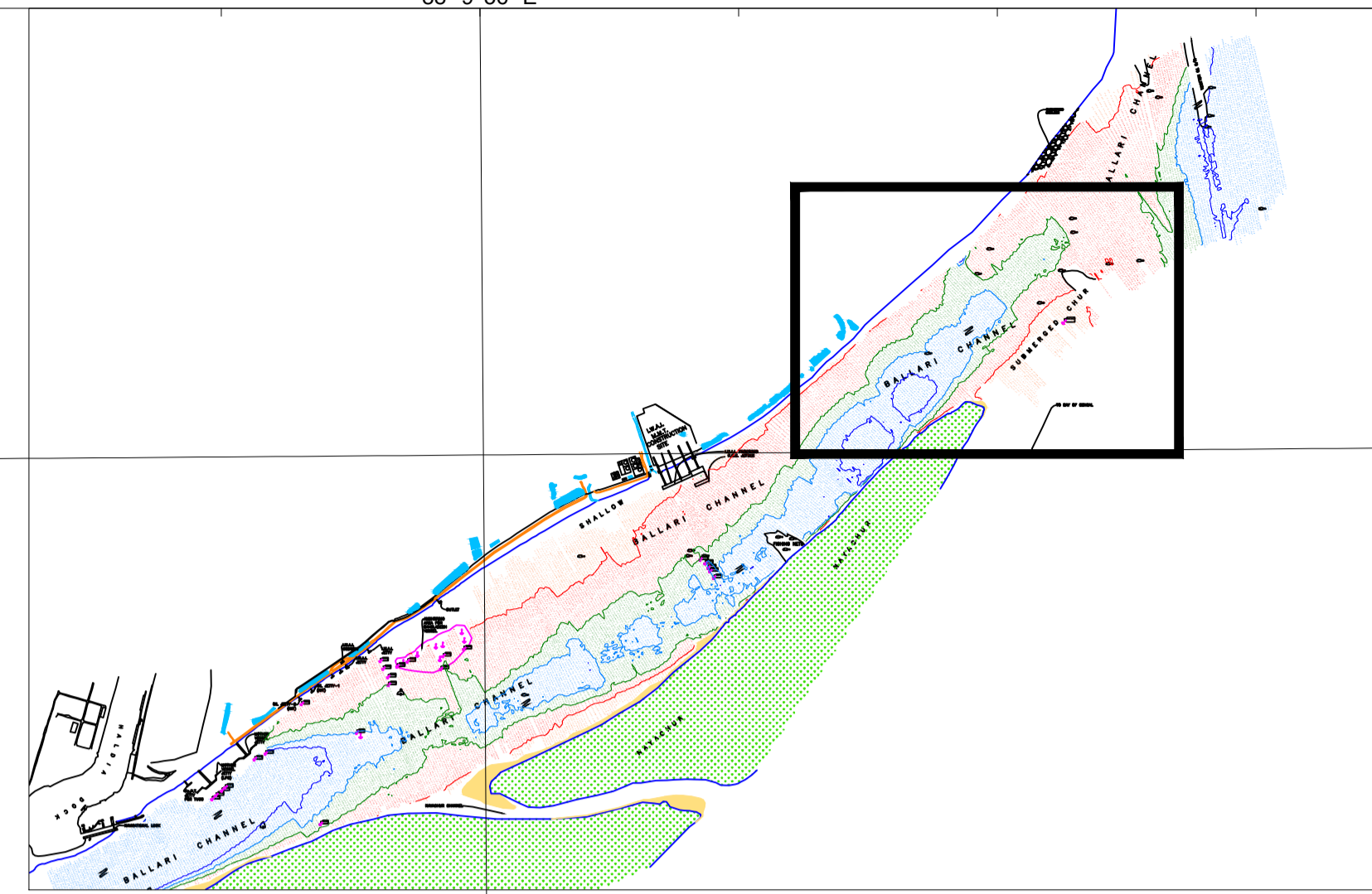
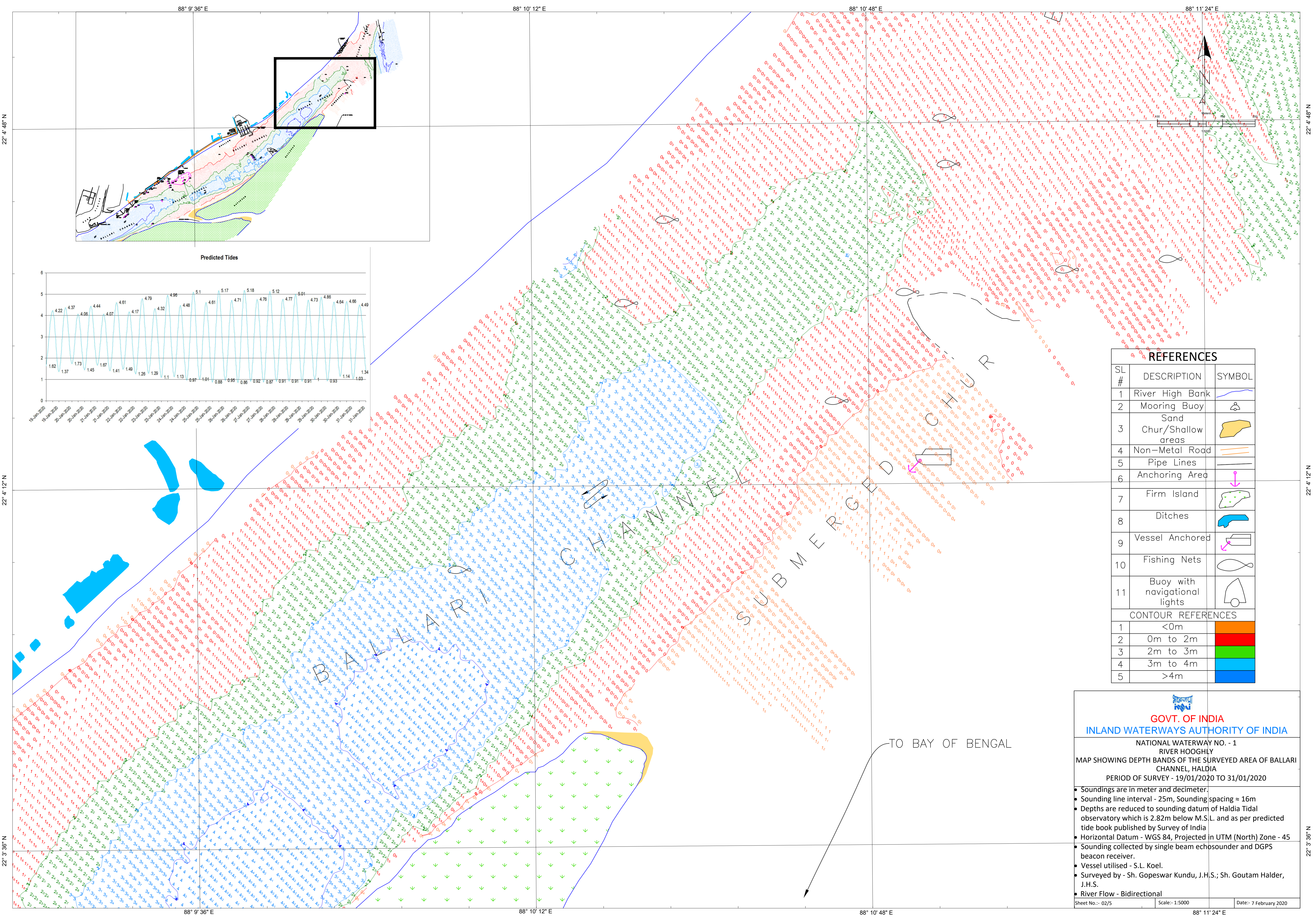

Predicted Tides

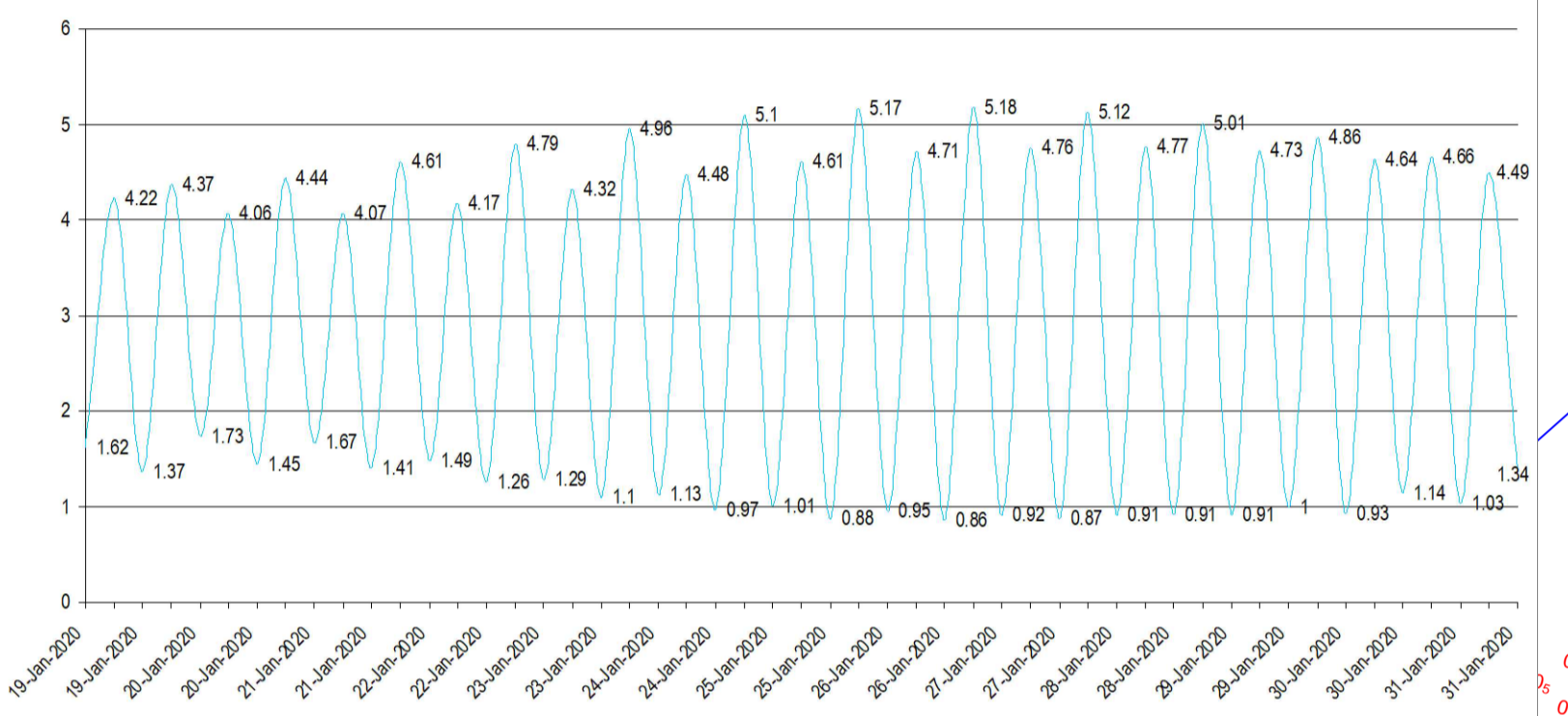

REFERENCES		
SL #	DESCRIPTION	SYMBOL
1	River High Bank	
2	Mooring Buoy	
3	Sand Chur/Shallow areas	
4	Non-Metal Road	
5	Pipe Lines	
6	Anchoring Area	
7	Firm Island	
8	Ditches	
9	Vessel Anchored	
10	Fishing Nets	
11	Buoy with navigational lights	
CONTOUR REFERENCES		
1	<0m	
2	0m to 2m	
3	2m to 3m	
4	3m to 4m	
5	>4m	

GOVT. OF INDIA
INLAND WATERWAYS AUTHORITY OF INDIA

NATIONAL WATERWAY NO. - 1
RIVER HOOGHLY
MAP SHOWING DEPTH BANDS OF THE SURVEYED AREA OF BALLARI CHANNEL, HALDIA
PERIOD OF SURVEY - 19/01/2020 TO 31/01/2020

- Soundings are in meter and decimeter.
- Sounding line interval - 25m, Sounding spacing ≈ 16m
- Depths are reduced to sounding datum of Haldia Tidal observatory which is 2.82m below M.S.L. and as per predicted tide book published by Survey of India
- Horizontal Datum - WGS 84, Projected in UTM (North) Zone - 45
- Sounding collected by single beam echosounder and DGPS beacon receiver.
- Vessel utilised - S.L. Koel.
- Surveyed by - Sh. Gopeswar Kundu, J.H.S.; Sh. Goutam Halder, J.H.S.
- River Flow - Bidirectional

Sheet No.: 02/5 Scale:- 1:5000 Date:- 7 February 2020

TO BAY OF BENGAL

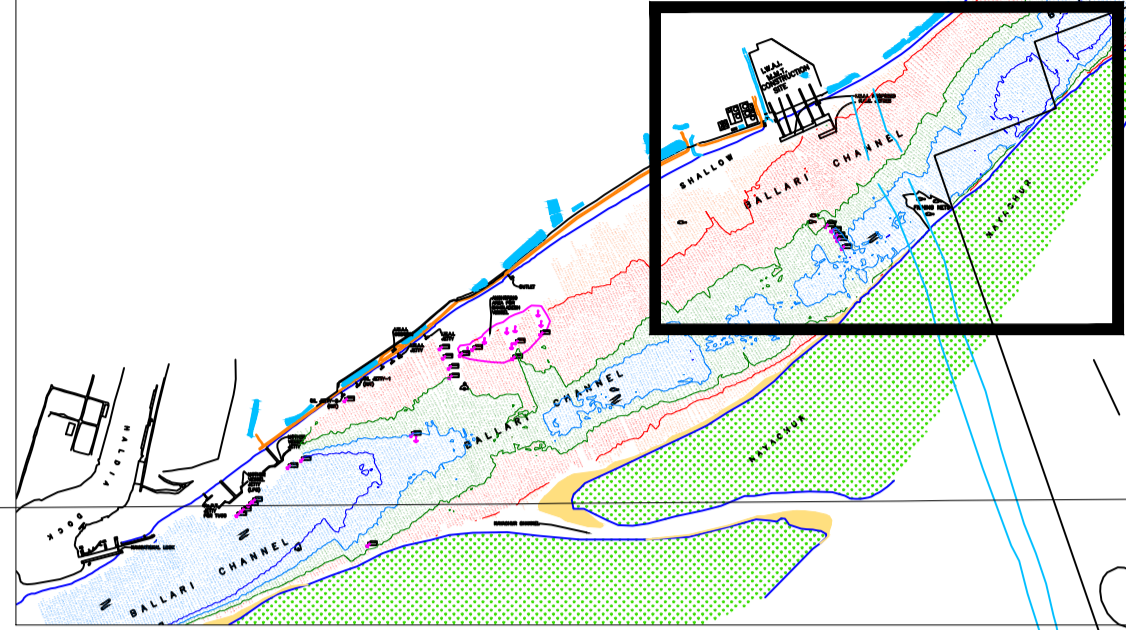
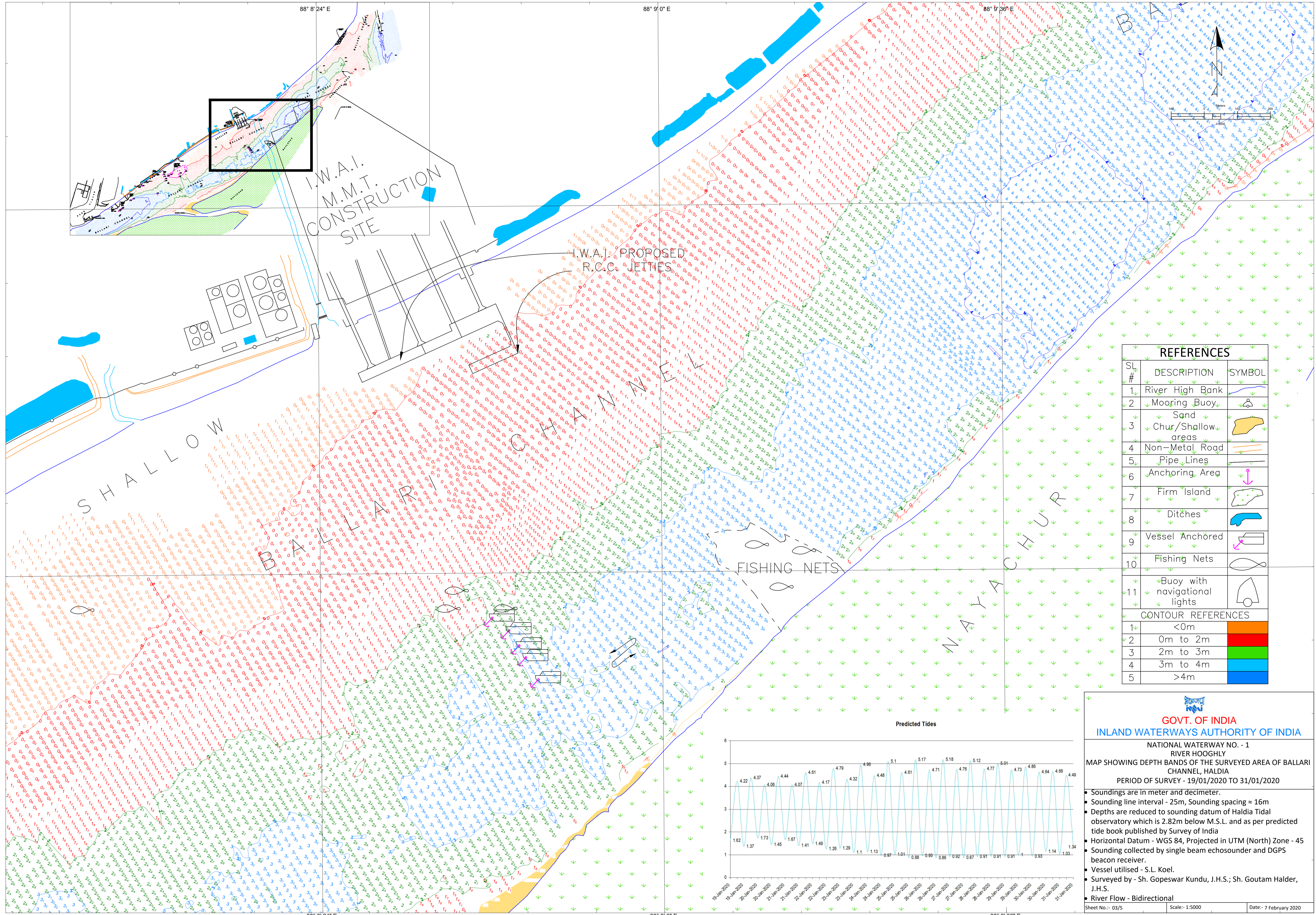

I.W.A.I.
M.M.T.
CONSTRUCTION
SITE

I.W.A.I. PROPOSED
R.C.C. JETTIES

SHALLOW

BALARI

FISHING NETS

NAYACHUR

REFERENCES		
SL #	DESCRIPTION	SYMBOL
1	River High Bank	
2	Mooring Buoy	
3	Sand Chur/Shallow areas	
4	Non-Metal Road	
5	Pipe Lines	
6	Anchoring Area	
7	Firm Island	
8	Ditches	
9	Vessel Anchored	
10	Fishing Nets	
11	Buoy with navigational lights	
CONTOUR REFERENCES		
1	<0m	
2	0m to 2m	
3	2m to 3m	
4	3m to 4m	
5	>4m	

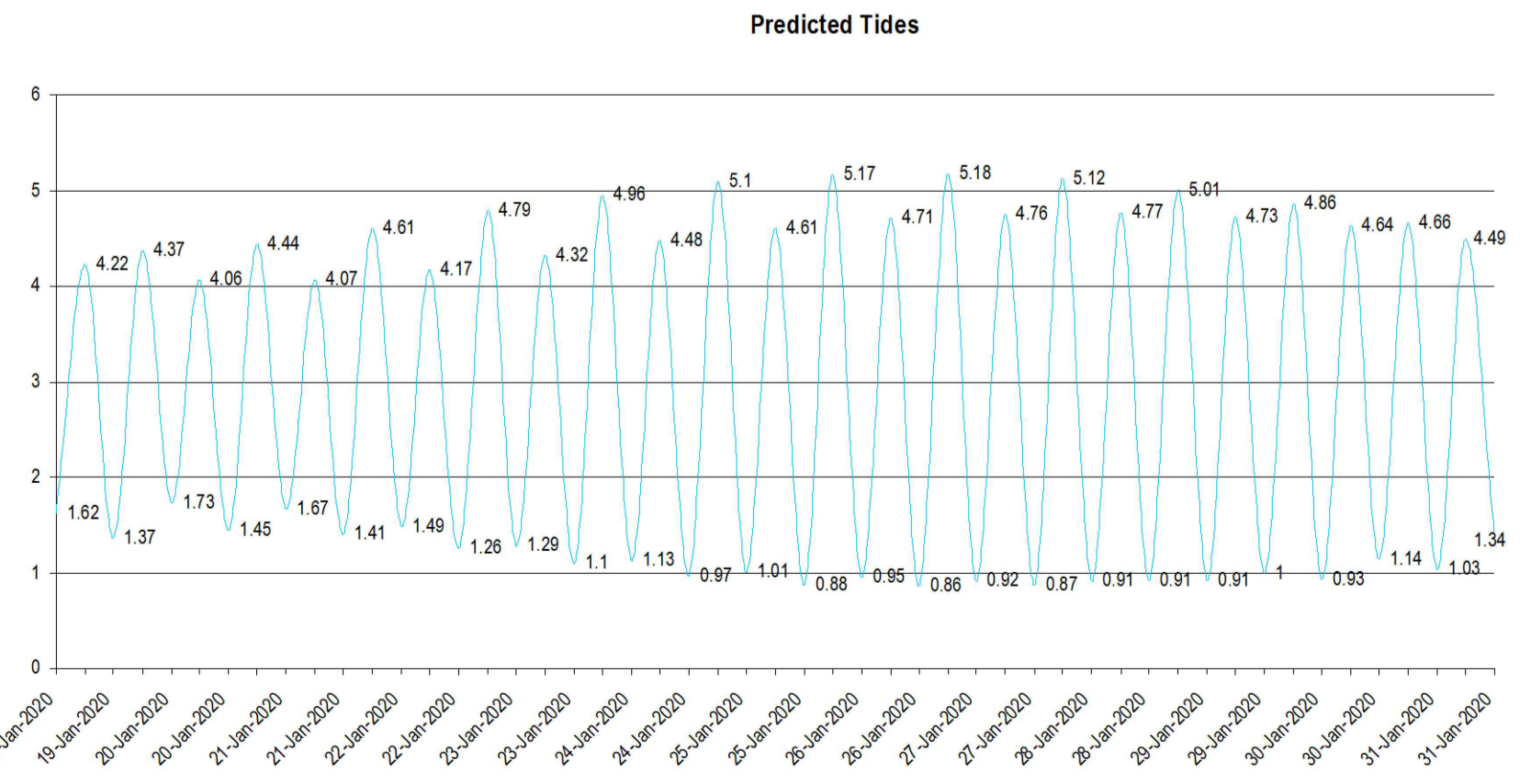

GOVT. OF INDIA
INLAND WATERWAYS AUTHORITY OF INDIA

NATIONAL WATERWAY NO. - 1
RIVER HOOGHLY
MAP SHOWING DEPTH BANDS OF THE SURVEYED AREA OF BALLARI CHANNEL, HALODIA
PERIOD OF SURVEY - 19/01/2020 TO 31/01/2020

- Soundings are in meter and decimeter.
- Sounding line interval - 25m, Sounding spacing ≈ 16m
- Depths are reduced to sounding datum of Halodia Tidal observatory which is 2.82m below M.S.L. and as per predicted tide book published by Survey of India
- Horizontal Datum - WGS 84, Projected in UTM (North) Zone - 45
- Sounding collected by single beam echosounder and DGPS beacon receiver.
- Vessel utilised - S.L. Koel.
- Surveyed by - Sh. Gopeswar Kundu, J.H.S.; Sh. Goutam Halder, J.H.S.
- River Flow - Bidirectional

Sheet No.: 03/5 Scale:- 1:5000 Date:- 7 February 2020

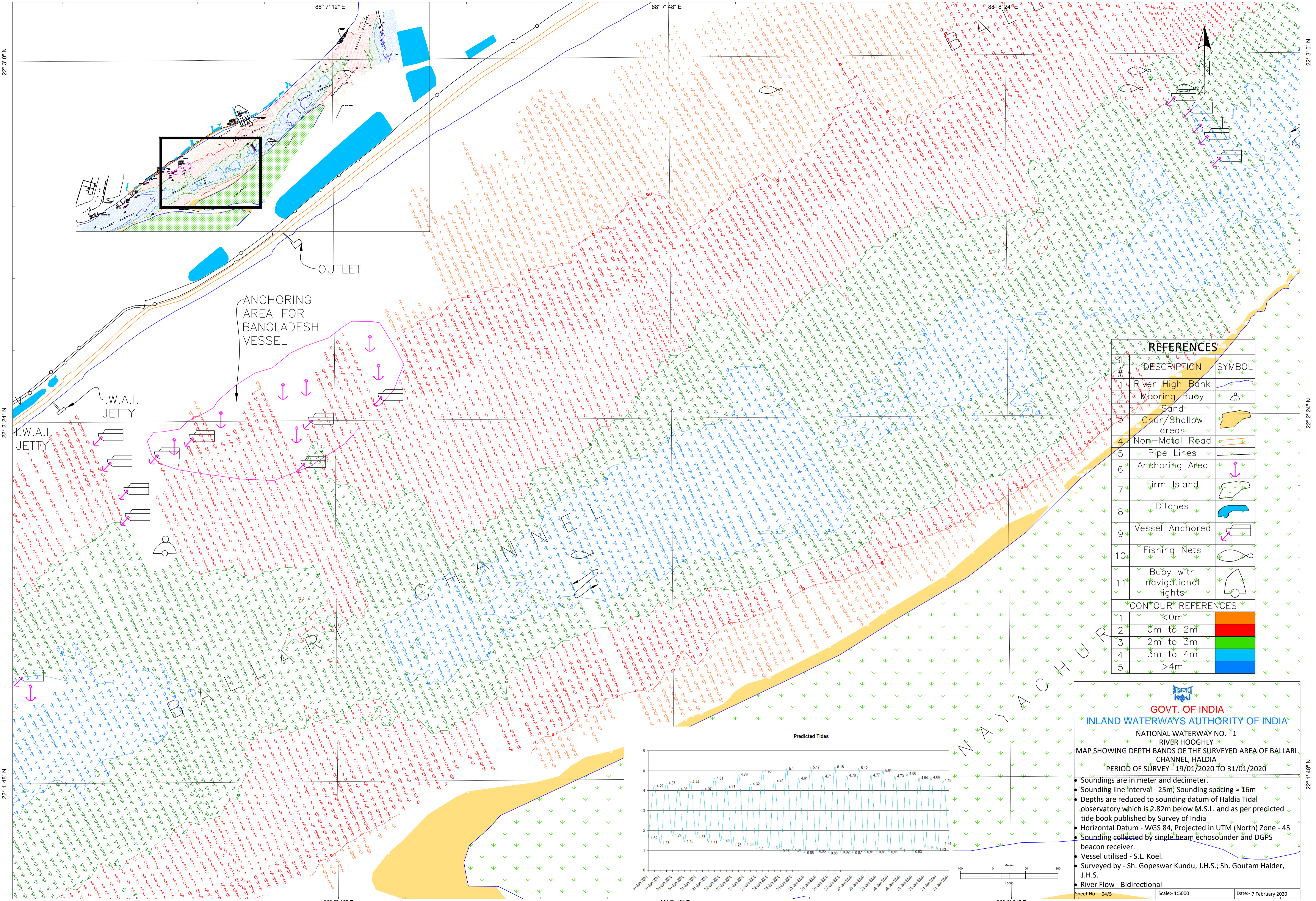

REFERENCES		
SL. #	DESCRIPTION	SYMBOL
1	River High Bank	
2	Mooring Buoy	
3	Sand	
4	Chur/Shallow areas	
5	Non-Metal Road	
6	Pipe Lines	
7	Anchoring Area	
8	Firm Island	
9	Ditches	
10	Vessel Anchored	
11	Fishing Nets	
	Buoy with navigational lights	
CONTOUR REFERENCES		
1	<0m	
2	0m to 2m	
3	2m to 3m	
4	3m to 4m	
5	>4m	

GOVT. OF INDIA
INLAND WATERWAYS AUTHORITY OF INDIA
 NATIONAL WATERWAY NO. - 1
 RIVER HOOGHLY
 MAP SHOWING DEPTH BANDS OF THE SURVEYED AREA OF BALLARI CHANNEL, HALDIA
 PERIOD OF SURVEY - 19/01/2020 TO 31/01/2020

- Soundings are in meter and decimeter.
- Sounding line interval - 25m; Sounding spacing ≈ 16m
- Depths are reduced to sounding datum of Haldia Tidal observatory which is 2.82m below M.S.L. and as per predicted tide book published by Survey of India
- Horizontal Datum - WGS 84, Projected in UTM (North) Zone - 45
- Sounding collected by single beam echosounder and DGPS beacon receiver.
- Vessel utilised - S.L. Koel.
- Surveyed by - Sh. Gopeswar Kundu, J.H.S.; Sh. Goutam Halder, J.H.S.
- River Flow - Bidirectional

Sheet No.: 04/5 Scale: 1:5000 Date: 7 February 2020

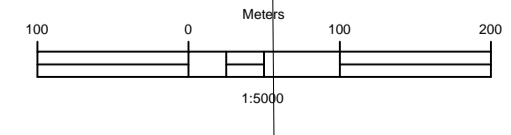
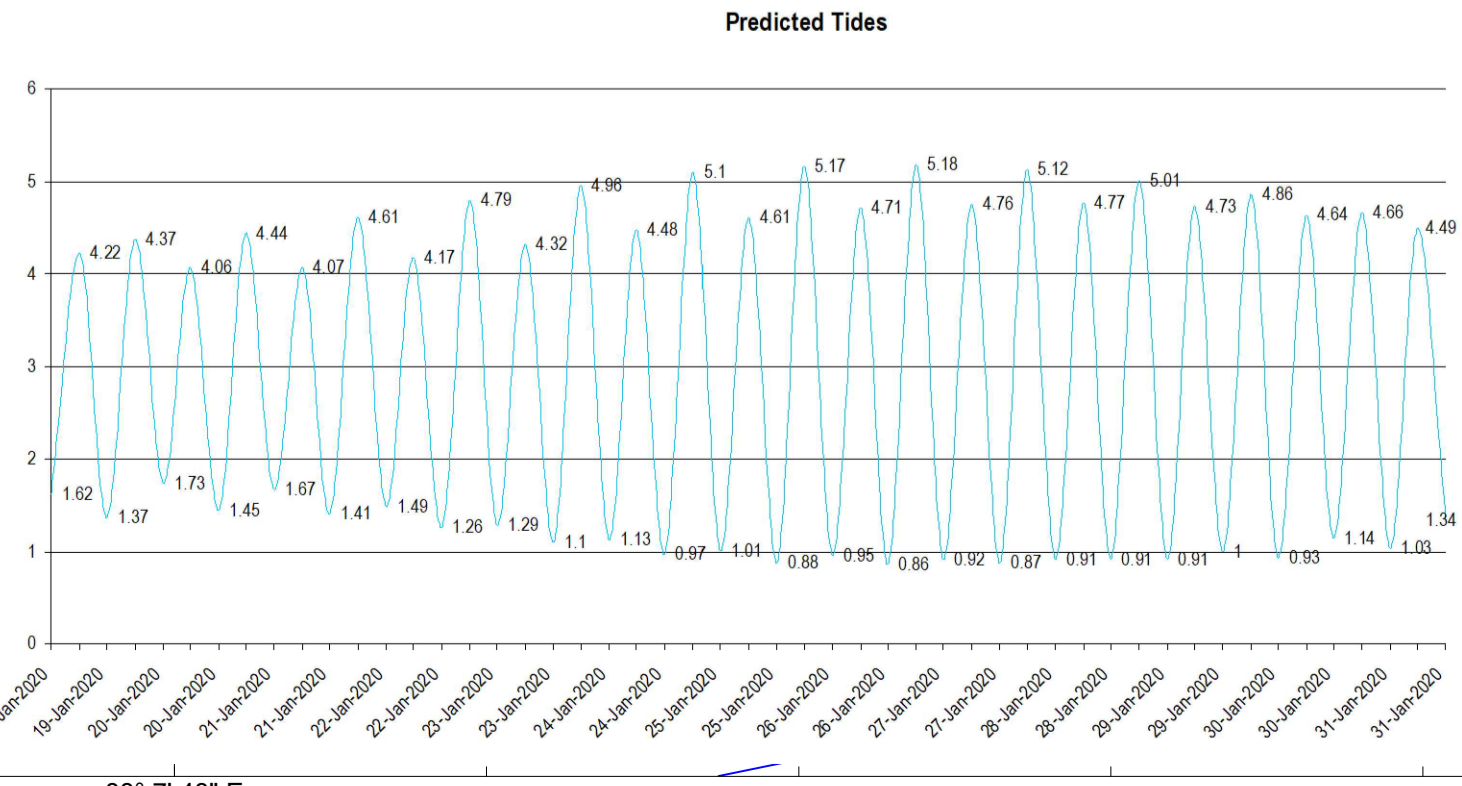

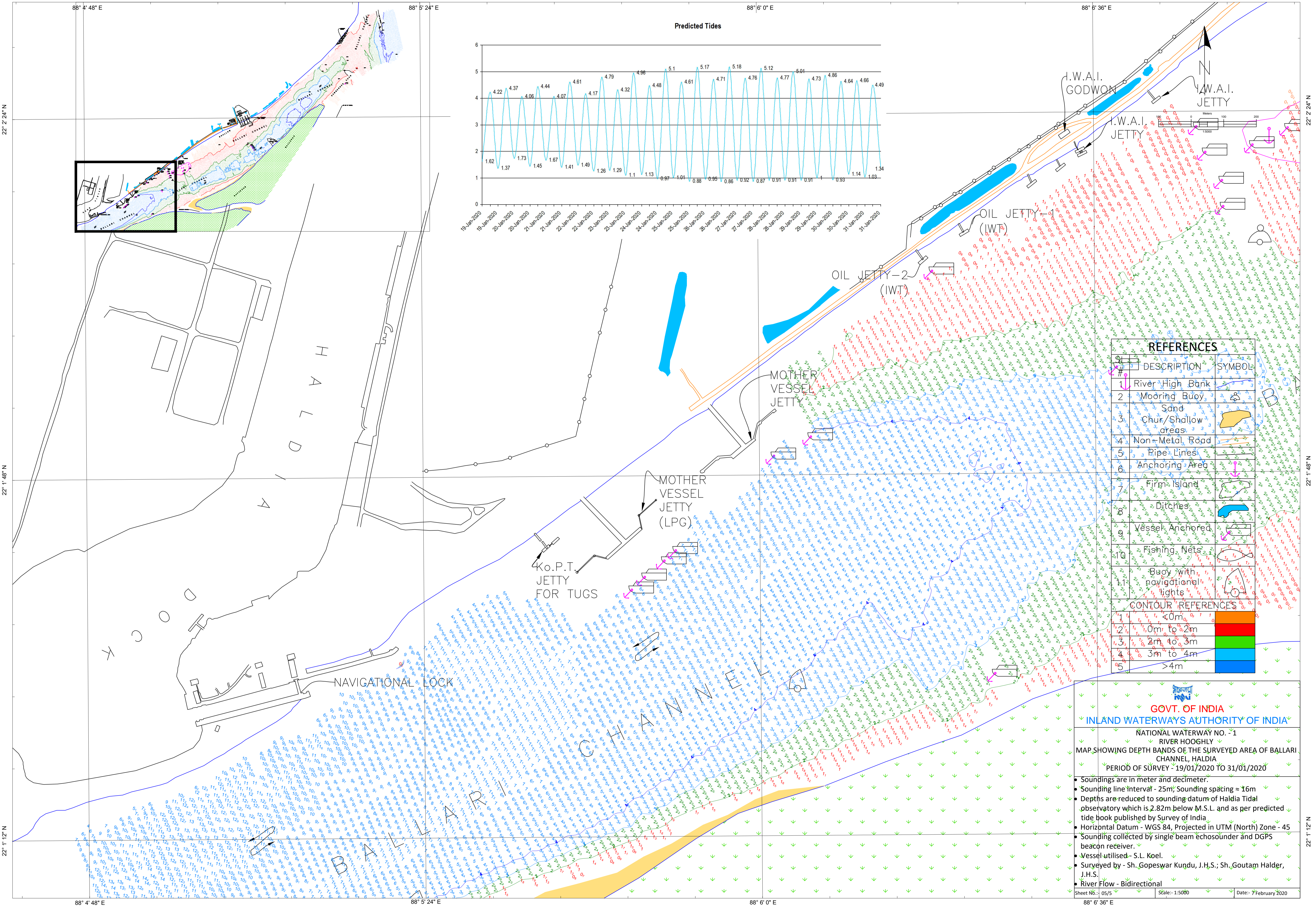

Predicted Tides

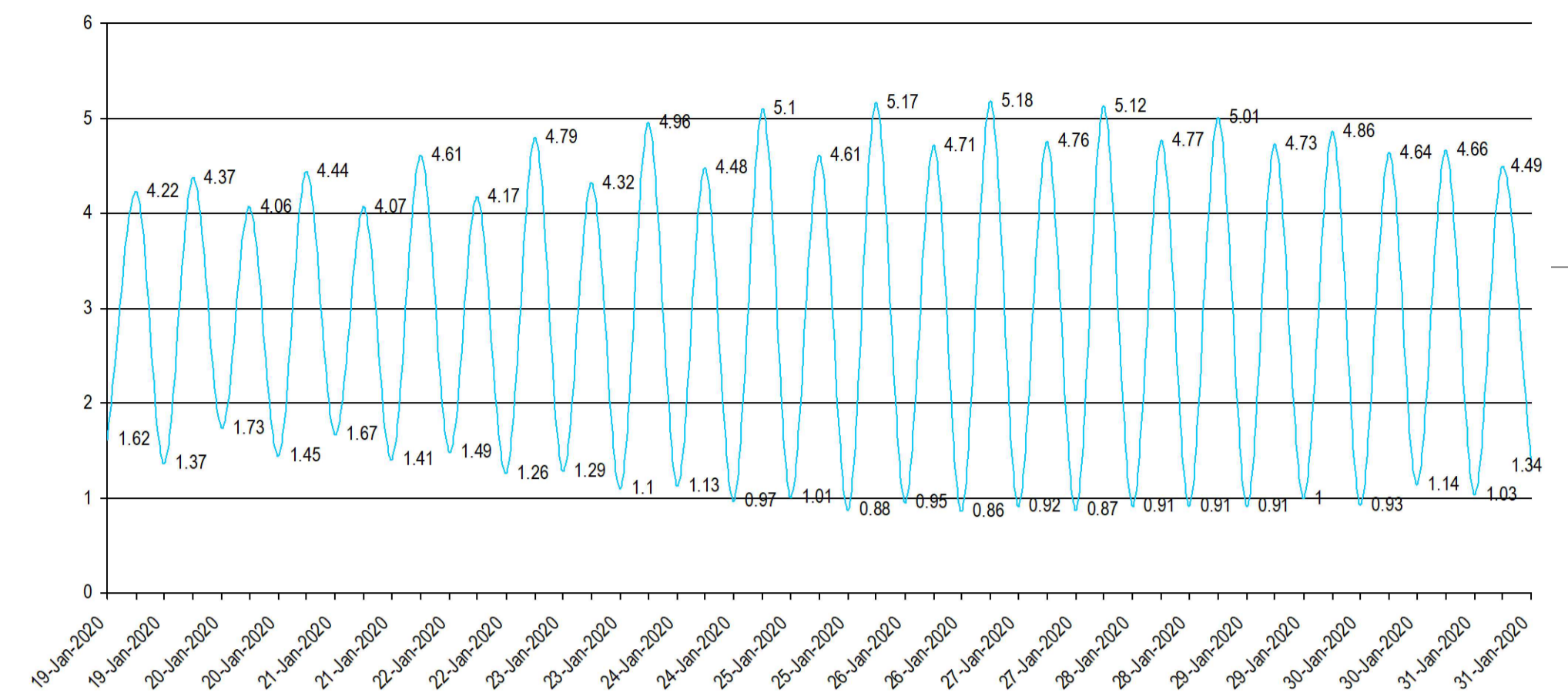

REFERENCES		
#	DESCRIPTION	SYMBOL
1	River High Bank	
2	Mooring Buoy	
3	Chur/Shallow areas	
4	Non-Metal Road	
5	Pipe Lines	
6	Anchoring Area	
7	Firm Island	
8	Ditches	
9	Vessel Anchored	
10	Fishing Nets	
11	Buoy with navigational lights	
CONTOUR REFERENCES		
1	<math>< 0\text{m}</math>	
2	0m to 2m	
3	2m to 3m	
4	3m to 4m	
5	>4m	

GOVT. OF INDIA
INLAND WATERWAYS AUTHORITY OF INDIA
 NATIONAL WATERWAY NO. -1
 RIVER HOOGHLY
 MAP SHOWING DEPTH BANDS OF THE SURVEYED AREA OF BALLARI CHANNEL, HALDA
 PERIOD OF SURVEY -19/01/2020 TO 31/01/2020

- Soundings are in meter and decimeter.
- Sounding line interval - 25m; Sounding spacing \approx 16m
- Depths are reduced to sounding datum of Haldia Tidal Observatory which is 2.82m below M.S.L. and as per predicted tide book published by Survey of India
- Horizontal Datum - WGS 84, Projected in UTM (North) Zone - 45
- Sounding collected by single beam echosounder and DGPS beacon receiver.
- Vessel utilised - S.L. Koel.
- Surveyed by - Sh. Gopeswar Kundu, J.H.S.; Sh. Goutam Halder, J.H.S.
- River Flow - Bidirectional

Sheet No.: 05/5 Scale:- 1:5000 Date:- 7 February 2020

Annexure 11: Historical hydrographic data

This page has been intentionally left blank. Please turn over to next page.

HALDIA (HUGLI RIVER) – INDIA

LAT. 22° 02' N. LONG. 88° 06' E.

TIME ZONE -0530

TIMES AND HEIGHTS OF HIGH AND LOW WATERS

YEAR 2017

MAY			JUNE			JULY			AUGUST						
TIME	Ht.		TIME	Ht.		TIME	Ht.		TIME	Ht.		TIME	Ht.		
	h m m			h m m			h m m			h m m			h m m		
1 M	0146 5.07 0859 1.05 1417 5.21 2127 1.38	16 TU	0115 4.79 0815 1.42 1342 5.05 2038 1.63	1 TH	0328 4.64 1007 1.92 1601 4.80 2302 1.90	16 F	0220 4.85 0905 1.78 1445 5.14 2146 1.73	1 SA	0341 4.77 1018 2.10 1606 4.78 2258 1.97	16 SU	0242 5.19 0935 1.72 1508 5.26 2212 1.55	1 TU	0441 4.58 1115 2.40 1713 4.40	16 W	0419 5.02 1117 1.99 1709 4.79 2359 1.78
2 TU	0242 4.66 0936 1.45 1515 4.82 2217 1.69	17 W	0151 4.61 0840 1.64 1419 4.90 2111 1.79	2 F	0436 4.47 1117 2.14 1709 4.64	17 SA	0311 4.78 0955 1.92 1542 5.02 2242 1.77	2 SU	0442 4.62 1123 2.29 1710 4.60	17 M	0338 5.08 1031 1.88 1612 5.07 2310 1.64	2 W	0003 2.19 0618 4.58 1304 2.38 1855 4.40	17 TH	0603 5.00 1304 1.97 1847 4.83
3 W	0352 4.32 1030 1.81 1635 4.54 2337 1.88	18 TH	0236 4.44 0916 1.86 1507 4.75 2202 1.92	3 SA	0010 1.97 0552 4.44 1239 2.19 1820 4.59	18 SU	0419 4.74 1107 2.01 1654 4.94 2353 1.74	3 M	0005 2.07 0557 4.60 1246 2.33 1825 4.53	18 TU	0455 5.02 1148 1.97 1736 4.95	3 TH	0139 2.09 0746 4.81 1429 2.15 2018 4.61	18 F	0142 1.70 0729 5.21 1445 1.71 2008 5.01
4 TH	0518 4.15 1202 2.02 1800 4.46	19 F	0338 4.31 1020 2.04 1618 4.65 2316 1.96	4 SU	0120 1.94 0712 4.58 1356 2.11 1933 4.65	19 M	0543 4.85 1232 1.97 1814 4.99	4 TU	0119 2.04 0719 4.75 1405 2.20 1945 4.61	19 W	0029 1.66 0624 5.14 1321 1.88 1856 5.03	4 F	0256 1.87 0842 5.11 1536 1.87 2108 4.86	19 SA	0314 1.4 0836 5.6 1605 1.3 2108 5.4
5 F	0104 1.87 0651 4.22 1335 1.98 1921 4.56	20 SA	0506 4.30 1151 2.09 1745 4.69	5 M	0228 1.83 0813 4.83 1507 1.95 2028 4.78	20 TU	0113 1.61 0659 5.13 1358 1.77 1923 5.16	5 W	0230 1.90 0820 5.00 1513 1.99 2043 4.78	20 TH	0157 1.53 0738 5.42 1451 1.64 2007 5.24	5 SA	0359 1.63 0928 5.40 1629 1.61 2146 5.08	20 SU	0429 1.7 0927 5.9 1707 1.6 2152 5.7
6 SA	0223 1.73 0809 4.49 1459 1.80 2022 4.73	21 SU	0045 1.83 0636 4.54 1325 1.92 1900 4.89	6 TU	0331 1.66 0858 5.10 1602 1.75 2112 4.91	21 W	0232 1.39 0800 5.51 1516 1.49 2022 5.39	6 TH	0334 1.70 0907 5.26 1608 1.77 2127 4.94	21 F	0319 1.31 0838 5.77 1608 1.34 2104 5.51	6 SU	0449 1.42 1001 5.64 1711 1.41 2215 5.29	21 M	0526 0. 1009 6. 1755 0. 2230 5.
7 SU	0335 1.53 0859 4.80 1604 1.59 2108 4.90	22 M	0209 1.57 0745 4.96 1447 1.62 2000 5.17	7 W	0421 1.48 0935 5.33 1645 1.57 2149 5.02	22 TH	0345 1.13 0851 5.90 1623 1.22 2112 5.63	7 F	0427 1.51 0947 5.47 1651 1.59 2202 5.08	22 SA	0432 1.07 0928 6.09 1708 1.08 2153 5.76	7 M	0530 1.26 1026 5.85 1747 1.26 2239 5.48	22 TU	0612 0. 1046 6. 1833 0. 2305 6.
8 M	0431 1.34 0936 5.08 1652 1.40 2145 5.03	23 TU	0323 1.24 0835 5.43 1556 1.29 2050 5.47	8 TH	0501 1.32 1007 5.50 1718 1.45 2220 5.10	23 F	0448 0.90 0937 6.21 1717 1.00 2200 5.83	8 SA	0509 1.37 1019 5.64 1726 1.46 2232 5.20	23 SU	0531 0.89 1014 6.32 1758 0.92 2238 5.93	8 TU	0603 1.13 1051 6.01 1821 1.13 2304 5.64	23 W	0648 0. 1121 0. 1906 0. 2340 0.
9 TU	0511 1.17 1004 5.31 1727 1.26 2216 5.11	24 W	0427 0.92 0917 5.87 1652 1.00 2134 5.73	9 F	0535 1.21 1035 5.61 1747 1.38 2248 5.16	24 SA	0541 0.75 1021 6.39 1806 0.90 2248 5.93	9 SU	0545 1.27 1045 5.75 1757 1.38 2258 5.30	24 M	0619 0.81 1056 6.41 1842 0.87 2321 5.99	9 W	0637 1.04 1117 6.09 1856 1.05 2335 5.75	24 TH	0721 1157 1936
10 W	0542 1.03 1031 5.46 1753 1.18 2243 5.16	25 TH	0519 0.66 0955 6.21 1740 0.79 2216 5.91	10 SA	0604 1.16 1103 5.65 1814 1.36 2317 5.19	25 SU	0628 0.73 1107 6.42 1851 0.91 2336 5.90	10 M	0616 1.22 1112 5.82 1831 1.33 2327 5.37	25 TU	0701 0.85 1139 6.35 1824 0.93	10 TH	0710 1.01 1150 6.08 1934 1.01	25 F	0016 0750 1234 2003
11 TH	0608 0.95 1056 5.54 1817 1.15 2309 5.17	26 F	0604 0.51 1036 6.38 1825 0.71 2302 5.96	11 SU	0632 1.16 1133 5.64 1844 1.37 2347 5.19	26 M	0712 0.83 1156 6.27 1937 1.03	11 TU	0648 1.21 1142 5.83 1907 1.31	26 W	0005 5.92 0739 1.00 1222 6.13 2001 1.09	11 F	0011 5.78 0744 1.04 1228 5.97 2009 1.04	26 SA	0053 0813 1309 2025
12 F	0631 0.92 1124 5.54 1842 1.16 2337 5.15	27 SA	0647 0.51 1122 6.36 1909 0.77 2350 5.84	12 M	0701 1.22 1205 5.58 1919 1.42	27 TU	0025 5.74 0752 1.04 1247 5.99 2020 1.22	12 W	0000 5.40 0720 1.24 1215 5.78 1946 1.33	27 TH	0048 5.74 0812 1.21 1305 5.84 2035 1.28	12 SA	0051 5.74 0817 1.15 1310 5.80 2042 1.10	27 SU	0127 0833 1343 2041
13 SA	0657 0.95 1156 5.49 1909 1.21	28 SU	0728 0.66 1214 6.14 1952 0.95	13 TU	0020 5.13 0732 1.33 1242 5.48 1956 1.50	28 W	0116 5.50 0830 1.31 1337 5.66 2101 1.43	13 TH	0037 5.38 0753 1.33 1254 5.69 2022 1.37	28 F	0130 5.51 0840 1.45 1346 5.51 2103 1.46	13 SU	0133 5.64 0846 1.31 1354 5.59 2112 1.22	28 M	0151 0851 141 210
14 SU	0008 5.08 0724 1.05 1232 5.37 1938 1.31	29 M	0041 5.58 0806 0.93 1306 5.80 2035 1.21	14 W	0057 5.04 0801 1.47 1319 5.36 2031 1.59	29 TH	0204 5.23 0904 1.59 1426 5.33 2137 1.64	14 F	0115 5.33 0824 1.44 1334 5.57 2055 1.41	29 SA	0207 5.27 0903 1.68 1422 5.20 2125 1.64	14 M	0215 5.48 0919 1.52 1440 5.33 2146 1.40	29 TU	023 091 144 213
15 M	0041 4.95 0750 1.21 1308 5.22 2009 1.46	30 TU	0133 5.25 0843 1.27 1401 5.42 2118 1.48	15 TH	0135 4.94 0829 1.63 1359 5.25 2106 1.67	30 F	0250 4.98 0937 1.66 1513 5.03 2213 1.82	15 SA	0157 5.27 0856 1.56 1419 5.43 2130 1.47	30 SU	0244 5.02 0927 1.93 1501 4.90 2152 1.84	15 TU	0306 5.26 1005 1.77 1538 5.03 2237 1.62	30 W	032 100 154 224

HALDIA (HUGLI RIVER) - INDIA

141

LAT. 22° 02' N. LONG. 88° 06' E.

TIME ZONE -0530

TIMES AND HEIGHTS OF HIGH AND LOW WATERS

YEAR 2017

SEPTEMBER			OCTOBER			NOVEMBER			DECEMBER						
TIME	Ht.		TIME	Ht.		TIME	Ht.		TIME	Ht.	TIME	Ht.			
h m	m		h m	m		h m	m		h m	m	h m	m			
1 F	0048 2.29 0706 4.58 1350 2.26 1954 4.41	16 SA	0140 1.86 0730 5.06 1443 1.70 2017 4.99	1 SU	0140 2.23 0732 4.68 1429 2.01 2018 4.59	16 M	0303 1.68 0827 5.16 1544 1.38 2104 5.25	1 W	0320 1.65 0830 5.13 1552 1.32 2059 5.34	16 TH	0438 1.41 0936 5.03 1656 1.21 2154 5.40	1 F	0338 1.41 0843 5.05 1604 1.03 2107 5.52	16 SA	0451 1.47 0957 4.56 1704 1.25 2211 5.11
2 SA	0222 2.04 0815 4.92 1508 1.93 2049 4.75	17 SU	0314 1.55 0836 5.43 1602 1.32 2110 5.38	2 M	0259 1.88 0826 5.06 1537 1.64 2059 5.01	17 TU	0412 1.38 0913 5.41 1642 1.14 2140 5.55	2 TH	0418 1.30 0912 5.45 1643 0.99 2131 5.77	17 F	0517 1.27 1011 5.11 1731 1.09 2220 5.54	2 SA	0438 1.09 0930 5.33 1701 0.75 2146 5.88	17 SU	0529 1.32 1034 4.66 1742 1.12 2242 5.22
3 SU	0333 1.73 0900 5.27 1608 1.61 2127 5.07	18 M	0426 1.23 0924 5.75 1700 1.02 2150 5.71	3 TU	0400 1.53 0907 5.42 1632 1.30 2130 5.42	18 W	0503 1.16 0951 5.57 1726 0.98 2207 5.76	3 F	0505 0.99 0950 5.74 1728 0.71 2201 6.12	18 SA	0548 1.18 1042 5.14 1758 1.02 2247 5.60	3 SU	0529 0.83 1014 5.56 1750 0.55 2226 6.11	18 M	0600 1.22 1106 4.73 1812 1.03 2312 5.28
4 M	0429 1.45 0936 5.59 1656 1.33 2154 5.39	19 TU	0520 0.99 1002 5.97 1745 0.83 2220 5.94	4 W	0450 1.22 0940 5.74 1715 0.99 2155 5.81	19 TH	0541 1.03 1023 5.65 1756 0.89 2232 5.88	4 SA	0547 0.76 1027 5.95 1807 0.51 2235 6.34	19 SU	0614 1.14 1112 5.15 1824 0.99 2317 5.58	4 M	0614 0.67 1059 5.69 1834 0.46 2309 6.18	19 TU	0629 1.17 1135 4.78 1841 1.00 2340 5.27
5 TU	0513 1.21 1005 5.87 1735 1.09 2218 5.68	20 W	0559 0.86 1035 6.08 1818 0.76 2247 6.05	5 TH	0530 0.95 1009 6.02 1751 0.74 2219 6.14	20 F	0611 0.99 1052 5.65 1820 0.88 2258 5.90	5 SU	0628 0.63 1106 6.04 1845 0.44 2315 6.38	20 M	0639 1.15 1142 5.12 1848 1.02 2347 5.50	5 TU	0701 0.63 1146 5.69 1917 0.52 2357 6.05	20 W	0658 1.15 1204 4.81 1909 1.01
6 W	0549 1.01 1029 6.10 1809 0.90 2242 5.94	21 TH	0632 0.85 1105 6.07 1844 0.79 2315 6.05	6 F	0607 0.75 1040 6.20 1825 0.56 2250 6.34	21 SA	0635 1.02 1120 5.59 1842 0.91 2327 5.84	6 M	0708 0.63 1149 5.96 1923 0.52	21 TU	0706 1.20 1211 5.05 1913 1.10	6 W	0746 0.72 1237 5.52 1958 0.71	21 TH	0011 5.22 0731 1.16 1236 4.79 1940 1.08
7 TH	0623 0.85 1056 6.24 1843 0.75 2310 6.11	22 F	0659 0.92 1137 5.95 1909 0.88 2348 5.95	7 SA	0643 0.64 1116 6.25 1901 0.49 2328 6.38	22 SU	0658 1.09 1151 5.48 1905 0.99	7 TU	0002 6.21 0750 0.78 1237 5.71 2000 0.76	22 W	0021 5.36 0736 1.28 1245 4.93 1941 1.24	7 TH	0050 5.76 0833 0.91 1329 5.24 2038 1.00	22 F	0046 5.12 0806 1.21 1312 4.72 2009 1.20
8 F	0658 0.77 1130 6.26 1918 0.69 2348 6.15	23 SA	0723 1.04 1207 5.76 1932 1.00	8 SU	0721 0.65 1156 6.13 1935 0.56	23 M	0000 5.71 0723 1.18 1222 5.33 1927 1.11	8 W	0053 5.87 0830 1.03 1327 5.35 2036 1.09	23 TH	0058 5.19 0806 1.41 1319 4.77 2009 1.43	8 F	0145 5.39 0917 1.15 1425 4.92 2118 1.32	23 SA	0123 4.99 0842 1.28 1349 4.62 2039 1.34
9 SA	0734 0.79 1208 6.14 1951 0.73	24 SU	0022 5.79 0747 1.19 1240 5.52 1953 1.15	9 M	0012 6.24 0758 0.80 1241 5.87 2009 0.77	24 TU	0036 5.52 0748 1.32 1254 5.13 1951 1.28	9 TH	0145 5.46 0910 1.34 1423 4.95 2115 1.48	24 F	0134 4.98 0837 1.57 1355 4.58 2035 1.65	9 SA	0242 5.01 1004 1.38 1523 4.62 2203 1.63	24 SU	0159 4.85 0916 1.35 1427 4.53 2110 1.49
10 SU	0028 6.07 0807 0.91 1251 5.91 2024 0.86	25 M	0056 5.58 0807 1.35 1311 5.27 2013 1.33	10 TU	0100 5.95 0831 1.06 1327 5.50 2040 1.08	25 W	0110 5.29 0811 1.50 1324 4.89 2014 1.53	10 F	0243 5.03 0958 1.64 1529 4.59 2207 1.84	25 SA	0210 4.78 0911 1.73 1436 4.40 2109 1.87	10 SU	0344 4.68 1056 1.57 1627 4.40 2303 1.87	25 M	0240 4.72 0951 1.41 1509 4.44 2148 1.63
11 M	0113 5.88 0837 1.13 1336 5.61 2054 1.08	26 TU	0128 5.32 0826 1.57 1340 4.98 2032 1.58	11 W	0147 5.57 0906 1.39 1418 5.09 2116 1.45	26 TH	0143 5.02 0837 1.74 1358 4.62 2037 1.81	11 SA	0359 4.69 1111 1.84 1656 4.38 2331 2.07	26 SU	0255 4.60 0956 1.87 1529 4.24 2204 2.06	11 M	0452 4.45 1159 1.68 1738 4.30	26 TU	0327 4.59 1032 1.46 1604 4.36 2245 1.76
12 TU	0157 5.60 0908 1.41 1423 5.25 2126 1.38	27 W	0159 5.02 0848 1.86 1413 4.66 2056 1.90	12 TH	0239 5.15 0949 1.74 1521 4.67 2208 1.84	27 F	0218 4.74 0910 2.00 1441 4.34 2114 2.11	12 SU	0529 4.54 1238 1.84 1827 4.41	27 M	0357 4.45 1100 1.92 1647 4.18 2327 2.14	12 TU	0021 1.99 0602 4.32 1305 1.71 1856 4.34	27 W	0429 4.45 1130 1.49 1716 4.35
13 W	0245 5.26 0951 1.75 1521 4.86 2215 1.71	28 TH	0237 4.68 0924 2.18 1458 4.32 2145 2.23	13 F	0358 4.76 1107 2.00 1705 4.43 2343 2.09	28 SA	0309 4.47 1007 2.21 1550 4.11 2234 2.35	13 M	0108 2.03 0654 4.60 1356 1.71 1949 4.65	28 TU	0522 4.41 1221 1.85 1819 4.33	13 W	0139 1.97 0719 4.30 1413 1.67 2006 4.52	28 TH	0000 1.82 0546 4.37 1244 1.46 1839 4.49
14 TH	0359 4.90 1103 2.03 1702 4.58 2346 1.96	29 F	0348 4.37 1040 2.42 1640 4.06 2334 2.42	14 SA	0550 4.66 1259 1.95 1852 4.53	29 SU	0449 4.33 1143 2.26 1753 4.10	14 TU	0231 1.84 0804 4.77 1508 1.53 2044 4.95	29 W	0101 2.02 0643 4.54 1344 1.63 1931 4.68	14 TH	0256 1.84 0825 4.36 1521 1.56 2057 4.74	29 F	0129 1.72 0705 4.43 1407 1.32 1949 4.78
15 F	0557 4.81 1303 2.01 1852 4.65	30 SA	0807 4.37 1300 2.34 1904 4.21	15 SU	0133 1.98 0723 4.86 1429 1.68 2013 4.88	30 M	0031 2.32 0631 4.48 1328 2.03 1923 4.42	15 W	0344 1.61 0855 4.92 1509 1.35 2123 5.20	30 TH	0227 1.74 0749 4.78 1459 1.34 2025 4.94	15 F	0402 1.65 0915 4.46 1618 1.41 2137 4.94	30 SA	0257 1.48 0814 4.62 1527 1.09 2046 5.14
					31 TU	0208 2.02 0738 4.79 1447 1.69 2020 4.87						31 SU	0413 1.18 0913 4.87 1638 0.83 2136 5.50		

DIAMOND HARBOUR (HUGLI RIVER) - INDIA

LAT. 22° 12' N. LONG. 88° 10' E.

TIME ZONE -0530

TIMES AND HEIGHTS OF HIGH AND LOW WATERS

YEAR

JANUARY			FEBRUARY			MARCH			APRIL						
TIME	Ht.		TIME	Ht.		TIME	Ht.		TIME	Ht.	TIME	Ht.			
h m m			h m m			h m m			h m m		h m m		h m m		
1 SU	0047 5.44 0848 1.10 1317 5.00 2058 1.08	16 M	0131 5.42 0945 0.98 1407 5.03 2148 1.11	1 W	0144 5.47 1000 0.73 1415 5.24 2205 0.90	16 TH	0213 5.01 1005 0.98 1440 4.89 2205 1.21	1 W	0036 5.87 0911 0.39 1302 5.73 2122 0.54	16 TH	0104 5.32 0908 0.78 1324 5.32 2116 0.98	1 SA	0143 5.63 0954 0.60 1405 5.68 2210 0.93	16 SU	013 092 140 213
2 M	0124 5.35 0927 1.11 1356 4.97 2132 1.16	17 TU	0213 5.15 1014 1.12 1445 4.84 2210 1.29	2 TH	0229 5.30 11034 0.80 1500 5.10 2237 1.06	17 F	0246 4.76 1025 1.12 1513 4.67 2226 1.42	2 TH	0118 5.74 0946 0.44 1345 5.63 2155 0.68	17 F	0137 5.13 0930 0.87 1401 5.16 2139 1.12	2 SU	0232 5.22 1025 0.90 1455 5.27 2243 1.26	17 M	021 093 143 215
3 TU	0204 5.23 1005 1.15 1437 4.91 2205 1.26	18 W	0252 4.88 1035 1.26 1522 4.63 2230 1.47	3 F	0316 5.06 1108 0.93 1546 4.91 2313 1.27	18 SA	0318 4.47 1045 1.32 1548 4.39 2250 1.70	3 F	0206 5.49 1018 0.58 1432 5.41 2225 0.89	18 SA	0209 4.90 0951 1.02 1433 4.94 2157 1.33	3 M	0324 4.77 1058 1.26 1552 4.84 2328 1.59	18 TU	024 095 150 221
4 W	0249 5.10 1041 1.18 1523 4.83 2241 1.39	19 TH	0329 4.61 1058 1.39 1559 4.42 2256 1.69	4 SA	0406 4.76 1147 1.12 1641 4.66	19 SU	0351 4.13 1114 1.58 1638 4.09 2334 1.98	4 SA	0253 5.16 1048 0.80 1519 5.11 2257 1.18	19 SU	0239 4.63 1010 1.25 1505 4.67 2218 1.59	4 TU	0433 4.34 1149 1.61 1720 4.50	19 W	03: 10: 16: 23
5 TH	0338 4.93 1122 1.24 1613 4.71 2328 1.55	20 F	0407 4.32 1127 1.57 1647 4.20 2335 1.93	5 SU	0004 1.53 0510 4.41 1243 1.34 1803 4.44	20 M	0446 3.78 1213 1.83 1818 3.91	5 SU	0341 4.76 1122 1.09 1612 4.74 2342 1.50	20 M	0308 4.31 1031 1.52 1542 4.36 2250 1.88	5 W	0053 1.82 0612 4.11 1326 1.82 1903 4.45	20 TH	04 11 17
6 F	0434 4.73 1211 1.33 1716 4.59	21 SA	0457 4.03 1213 1.76 1800 4.02	6 M	0123 1.71 0643 4.17 1407 1.48 1937 4.46	21 TU	0111 2.13 0639 3.58 1406 1.88 2002 4.02	6 M	0443 4.33 1213 1.42 1737 4.41	21 TU	0349 3.98 1112 1.81 1651 4.08 2359 2.10	6 TH	0237 1.75 0755 4.19 1507 1.73 2028 4.65	21 F	00 06 10 15
7 SA	0032 1.70 0546 4.53 1317 1.41 1839 4.56	22 SU	0048 2.11 0617 3.80 1340 1.85 1931 4.04	7 TU	0307 1.67 0815 4.20 1543 1.40 2057 4.70	22 W	0310 1.96 0835 3.70 1544 1.68 2113 4.32	7 TU	0103 1.76 0624 4.04 1344 1.63 1922 4.37	22 W	0515 3.70 1247 2.00 1852 4.05	7 F	0408 1.52 0912 4.51 1634 1.50 2128 4.93	22 SA	0: 0: 1: 2:
8 SU	0154 1.73 0711 4.45 1437 1.40 1959 4.73	23 M	0236 2.06 0755 3.76 1513 1.74 2054 4.25	8 W	0447 1.41 0933 4.42 1713 1.19 2157 5.02	23 TH	0437 1.66 0945 4.01 1700 1.42 2202 4.67	8 W	0257 1.72 0809 4.08 1530 1.55 2049 4.60	23 TH	0204 2.06 0731 3.74 1447 1.88 2019 4.32	8 SA	0518 1.26 1002 4.85 1740 1.27 2211 5.17	23 SU	0 0 1 2
9 M	0327 1.59 0828 4.53 1601 1.27 2104 5.01	24 TU	0403 1.83 0919 3.92 1628 1.53 2149 4.53	9 TH	0602 1.10 1031 4.72 1821 0.95 2243 5.31	24 F	0543 1.36 1029 4.37 1802 1.18 2237 5.02	9 TH	0437 1.44 0930 4.38 1702 1.30 2149 4.93	24 F	0347 1.76 0859 4.09 1616 1.60 2116 4.70	9 SU	0613 1.07 1038 5.15 1828 1.10 2246 5.34	24 M	0 1 2
10 TU	0454 1.33 0934 4.73 1720 1.07 2157 5.32	25 W	0510 1.57 1015 4.14 1732 1.32 2233 4.80	10 F	0659 0.85 1115 4.99 1915 0.78 2323 5.53	25 SA	0636 1.08 1103 4.76 1852 0.95 2306 5.36	10 F	0548 1.12 1023 4.73 1809 1.05 2234 5.22	25 SA	0503 1.41 0950 4.54 1725 1.29 2158 5.11	10 M	0653 0.93 1105 5.39 1905 1.01 2313 5.45	25 TU	0 : :
11 W	0606 1.07 1030 4.95 1826 0.88 2243 5.57	26 TH	0606 1.35 1057 4.38 1825 1.15 2305 5.06	11 SA	0746 0.70 1152 5.20 1957 0.70 2357 5.63	26 SU	0719 0.82 1129 5.14 1933 0.75 2332 5.66	11 SA	0644 0.88 1102 5.04 1859 0.87 2309 5.43	26 SU	0605 1.06 1025 5.02 1822 0.99 2231 5.50	11 TU	0723 0.85 1128 5.56 1933 0.97 2338 5.48	26 W	
12 TH	0703 0.86 1117 5.16 1921 0.76 2324 5.74	27 F	0653 1.16 1128 4.65 1909 1.00 2332 5.30	12 SU	0823 0.65 1225 5.30 2033 0.72	27 M	0758 0.60 1154 5.47 2011 0.59	12 SU	0726 0.73 1132 5.27 1938 0.78 2338 5.54	27 M	0653 0.75 1053 5.49 1908 0.73 2301 5.84	12 W	0746 0.81 1151 5.64 1955 0.98	27 TH	
13 F	0752 0.76 1200 5.28 2006 0.73	28 SA	0732 1.00 1156 4.91 1946 0.88 2358 5.49	13 M	0030 5.59 0854 0.69 1257 5.29 2102 0.80	28 TU	0000 5.84 0834 0.44 1225 5.68 2047 0.51	13 M	0758 0.67 1158 5.42 2007 0.77	28 TU	0735 0.49 1119 5.88 1948 0.53 2331 6.05	13 TH	0004 5.45 0807 0.81 1218 5.64 2018 1.01	28 F	
14 SA	0006 5.76 0835 0.75 1244 5.29 2045 0.80	29 SU	0808 0.85 1224 5.13 2022 0.79	14 TU	0104 5.45 0921 0.78 1331 5.20 2126 0.92			14 TU	0005 5.55 0824 0.68 1223 5.46 2033 0.82	29 W	0812 0.32 1151 6.11 2026 0.45	14 F	0033 5.36 0830 0.85 1250 5.56 2042 1.08	29 SA	
15 SU	0047 5.65 0912 0.84 1325 5.20 2119 0.94	30 M	0028 5.59 0847 0.75 1256 5.26 2057 0.76	15 W	0139 5.24 0944 0.88 1406 5.06 2147 1.05			15 W	0033 5.47 0846 0.72 1251 5.42 2055 0.89	30 TH	0009 6.09 0848 0.28 1229 6.15 2102 0.49	15 SA	0105 5.22 0855 0.95 1326 5.40 2108 1.21	30 SU	
		31 TU	0103 5.58 0924 0.71 1334 5.29 2131 0.80					31 F	0053 5.94 0923 0.38 1316 5.99 2138 0.66						

DIAMOND HARBOUR (HUGLI RIVER) - INDIA

143

LAT. 22° 12' N. LONG. 88° 10' E.

TIMES AND HEIGHTS OF HIGH AND LOW WATERS

YEAR 2017

MAY

JUNE

JULY

AUGUST

MAY		JUNE		JULY		AUGUST							
TIME	Ht.	TIME	Ht.	TIME	Ht.	TIME	Ht.						
h m	m	h m	m	h m	m	h m	m						
16 TU	0150 4.96 0916 1.48 1409 5.22 2138 1.67	1 TH	0402 4.82 1107 1.89 1629 4.96	16 F	0253 5.01 1006 1.82 1513 5.27 2246 1.78	1 SA	0415 4.93 1116 2.10 1635 4.95 2356 1.98	16 SU	0314 5.36 1037 1.79 1536 5.43 2314 1.64	1 TU	0515 4.75 1210 2.40 1741 4.58	16 W	0450 5.20 1216 2.04 1736 4.97
17 W	0226 4.77 0941 1.68 1446 5.03 2210 1.83	2 F	0000 1.87 0509 4.64 1213 2.09 1738 4.79	17 SA	0344 4.93 1055 1.96 1610 5.15 2341 1.81	2 SU	0516 4.78 1218 2.27 1739 4.77	17 M	0410 5.24 1131 1.94 1640 5.23	2 W	0057 2.20 0649 4.75 1354 2.36 1921 4.56	17 TH	0058 1.86 0634 5.17 1358 2.01 1914 4.99
18 TH	0308 4.61 1015 1.88 1535 4.87 2259 1.94	3 SA	0107 1.93 0623 4.60 1331 2.14 1849 4.74	18 SU	0450 4.89 1203 2.04 1722 5.08	3 M	0101 2.06 0629 4.75 1337 2.30 1854 4.70	18 TU	0011 1.72 0527 5.17 1244 2.02 1804 5.11	3 TH	0229 2.09 0816 4.96 1517 2.13 2044 4.76	3 F	0237 1.77 0758 5.41 1536 1.74 2036 5.26
19 F	0408 4.47 1116 2.05 1646 4.77	4 SU	0214 1.90 0742 4.73 1446 2.07 2001 4.82	19 M	0050 1.78 0613 4.99 1324 1.99 1843 5.13	4 TU	0212 2.02 0749 4.89 1454 2.17 2013 4.77	19 W	0127 1.73 0655 5.28 1413 1.92 1925 5.18	4 F	0344 1.86 0912 5.26 1624 1.85 2138 5.00	19 SA	0406 1.52 0904 5.76 1657 1.41 2137 5.61
20 SA	0011 1.96 0534 4.45 1243 2.09 1814 4.81	5 M	0321 1.80 0842 4.97 1556 1.92 2057 4.95	20 TU	0209 1.65 0728 5.26 1449 1.79 1953 5.30	5 W	0322 1.88 0849 5.14 1601 1.97 2111 4.93	20 TH	0252 1.60 0807 5.56 1542 1.67 2036 5.40	5 SA	0448 1.63 0956 5.54 1720 1.63 2219 5.24	20 SU	0522 1.25 0955 6.11 1801 1.13 2223 5.94
21 SU	0138 1.84 0704 4.68 1415 1.93 1929 5.02	6 TU	0423 1.66 0927 5.23 1652 1.74 2143 5.08	21 W	0327 1.44 0828 5.63 1608 1.52 2051 5.54	6 TH	0425 1.70 0937 5.39 1658 1.76 2159 5.09	21 F	0413 1.38 0906 5.91 1701 1.39 2134 5.67	6 SU	0541 1.46 1033 5.78 1806 1.46 2251 5.47	6 M	0622 1.04 1036 6.37 1854 0.95 2301 6.18
22 M	0301 1.59 0812 5.08 1538 1.64 2030 5.31	7 W	0515 1.50 1004 5.47 1739 1.58 2221 5.20	22 TH	0440 1.20 0918 6.02 1718 1.25 2142 5.79	7 F	0519 1.53 1018 5.62 1745 1.59 2236 5.24	22 SA	0527 1.16 0955 6.24 1805 1.14 2224 5.94	7 M	0626 1.33 1100 6.00 1845 1.33 2315 5.69	7 TU	0712 0.94 1111 6.51 1935 0.89 2333 6.29
23 TU	0417 1.29 0903 5.55 1650 1.33 2120 5.62	8 TH	0555 1.36 1038 5.66 1815 1.46 2254 5.29	23 F	0545 0.99 1002 6.35 1817 1.05 2229 6.00	8 SA	0603 1.41 1051 5.80 1823 1.49 2309 5.38	23 SU	0629 0.99 1039 6.48 1859 1.00 2307 6.13	8 TU	0702 1.24 1124 6.18 1920 1.23 2338 5.88	8 W	0750 0.95 1145 6.49 2009 0.95
24 W	0524 1.00 0943 6.00 1750 1.05 2202 5.90	9 F	0631 1.27 1106 5.80 1846 1.40 2322 5.36	24 SA	0641 0.86 1044 6.56 1909 0.95 2315 6.12	9 SU	0641 1.33 1118 5.93 1856 1.42 2335 5.50	24 M	0720 0.92 1119 6.59 1945 0.96 2348 6.20	9 W	0737 1.17 1147 6.28 1954 1.17	9 TH	0004 6.27 0824 1.06 1219 6.34 2038 1.09
25 TH	0619 0.77 1018 6.36 1842 0.85 2242 6.10	10 SA	0701 1.22 1134 5.86 1914 1.38 2352 5.39	25 SU	0731 0.83 1128 6.60 1956 0.96	10 M	0714 1.30 1144 6.01 1929 1.39	25 TU	0804 0.96 1201 6.52 2027 1.03	10 TH	0006 6.00 0810 1.15 1218 6.28 2031 1.15	10 F	0038 6.12 0852 1.23 1258 6.08 2104 1.25
26 F	0707 0.63 1057 6.57 1930 0.77 2327 6.16	11 SU	0730 1.23 1202 5.86 1943 1.40	26 M	0002 6.10 0816 0.92 1216 6.46 2042 1.08	11 TU	0002 5.59 0746 1.30 1212 6.03 2003 1.38	26 W	0030 6.12 0843 1.11 1244 6.32 2103 1.19	11 F	0038 6.03 0844 1.19 1256 6.19 2107 1.18	11 SA	0116 5.92 0915 1.41 1335 5.80 2126 1.41
27 SA	0752 0.63 1140 6.58 2014 0.83	12 M	0021 5.38 0759 1.28 1234 5.79 2017 1.46	27 TU	0052 5.94 0856 1.12 1307 6.18 2123 1.27	12 W	0033 5.61 0819 1.34 1244 5.97 2041 1.41	27 TH	0113 5.94 0915 1.31 1329 6.02 2136 1.38	12 SA	0118 5.97 0918 1.29 1338 6.02 2141 1.26	12 SU	0152 5.68 0936 1.60 1410 5.50 2147 1.58
28 SU	0014 6.05 0833 0.76 1231 6.37 2057 1.00	13 TU	0055 5.32 0832 1.39 1309 5.66 2052 1.55	28 W	0144 5.69 0934 1.37 1400 5.84 2202 1.48	13 TH	0108 5.58 0852 1.42 1322 5.86 2118 1.46	28 F	0157 5.69 0942 1.54 1412 5.70 2203 1.56	13 SA	0201 5.86 0949 1.43 1422 5.80 2214 1.37	13 M	0229 5.42 0953 1.81 1442 5.19 2206 1.79
29 M	0108 5.80 0911 1.01 1325 6.02 2138 1.25	14 W	0131 5.22 0901 1.53 1347 5.52 2128 1.65	29 TH	0234 5.41 1006 1.63 1452 5.50 2237 1.67	14 F	0146 5.52 0925 1.53 1402 5.73 2154 1.52	29 SA	0237 5.44 1006 1.76 1451 5.40 2226 1.73	14 SU	0244 5.68 1023 1.62 1509 5.54 2250 1.53	14 M	0305 5.12 1017 2.07 1519 4.84 2234 2.05
30 TU	0203 5.46 0947 1.31 1423 5.62 2219 1.50	15 TH	0209 5.10 0931 1.68 1426 5.38 2204 1.73	30 F	0323 5.15 1038 1.88 1541 5.20 2311 1.84	15 SA	0228 5.45 0958 1.65 1447 5.60 2231 1.57	30 SU	0317 5.20 1028 1.98 1531 5.10 2252 1.91	15 TU	0337 5.45 1107 1.85 1606 5.22 2339 1.73	15 W	0355 4.79 1102 2.35 1617 4.50 2335 2.29
31 W	0302 5.11 1023 1.62 1523 5.24 2303 1.72					31 M	0404 4.95 1103 2.22 1620 4.80 2334 2.10			31 TH	0545 4.59 1245 2.47 1824 4.35		

MAYAPUR (HUGLI RIVER) - INDIA

LAT. 22° 26' N. LONG. 88° 08' E.

TIME ZONE -0530

TIMES AND HEIGHTS OF HIGH AND LOW WATERS

YEAR 2017

JANUARY

FEBRUARY

MARCH

APRIL

JANUARY			FEBRUARY			MARCH			APRIL					
TIME	Ht.		TIME	Ht.		TIME	Ht.		TIME	Ht.	TIME	Ht.		
h	m	m	h	m	m	h	m	m	h	m	h	m		
1 SU	0222	5.00	16 M	0308	5.00	1 W	0319	5.05	16 TH	0234	1 SA	0307	5.25	
	1049	1.14		1147	1.00		1158	0.70		1109	0.41		1146	0.46
	1430	4.65		1528	4.65		1536	4.76		1425	5.26		1528	5.21
	2250	1.05		2341	1.09					2323	0.59		2312	0.91
2 M	0257	4.95	17 TU	0348	4.75	2 TH	0009	0.93	2 W	0251	5.31	2 SA	0010	0.88
	1126	1.13		1214	1.07		0403	4.89		1143	0.39		0356	4.85
	1509	4.58		1608	4.42		1228	0.69		1509	5.15		1212	0.67
	2328	1.16					1624	4.62		2359	0.70		1618	4.80
3 TU	0336	4.86	18 W	0007	1.23	3 TH	0042	1.04	3 F	0336	5.09	3 SU	0041	1.11
	1201	1.12		0424	4.49		0448	4.65		1212	0.45		0450	4.39
	1554	4.49		1234	1.12		1256	0.73		1556	4.92		1241	0.95
				1648	4.20		1715	4.42		2353	1.14		1718	4.36
4 W	0006	1.26	19 TH	0030	1.37	4 SA	0117	1.19	4 F	0029	0.86	4 TU	0122	1.35
	0421	4.72		0500	4.22		0538	4.33		0422	4.77		0601	3.94
	1234	1.09		1252	1.19		1329	0.84		1237	0.58		1328	1.25
	1645	4.39		1728	3.96		1816	4.17		1646	4.61		1852	3.99
5 TH	0045	1.36	20 F	0055	1.52	5 SU	0205	1.37	5 M	0058	1.06	5 W	0246	1.51
	0510	4.54		0538	3.91		0642	3.97		0511	4.36		0743	3.67
	1310	1.07		1316	1.30		1421	1.02		1304	0.79		1505	1.45
	1741	4.26		1820	3.72		1942	3.95		1743	4.24		2040	3.92
6 F	0132	1.47	21 SA	0133	1.69	6 M	0321	1.51	6 TU	0139	1.30	6 TH	0429	1.42
	0608	4.31		0629	3.59		0814	3.72		0614	3.91		0927	3.74
	1354	1.09		1358	1.44		1544	1.14		1351	1.06		1650	1.41
	1850	4.14		1937	3.54		2119	3.97		1914	3.90		2209	4.12
7 M	0233	1.58	22 SU	0243	1.82	7 TH	0505	1.47	7 F	0258	1.49	7 SA	0601	1.22
	0718	4.10		0749	3.35		0943	3.75		0755	3.59		1043	4.06
	1457	1.13		1523	1.52		1723	1.11		1521	1.26		1824	1.25
	2017	4.11		2110	3.54		2239	4.20		2103	3.86		2308	4.41
8 W	0354	1.60	23 M	0432	1.76	8 TH	0647	1.27	8 TU	0452	1.44	8 TH	0713	1.04
	0840	4.03		0925	3.32		1058	3.99		0939	3.62		1131	4.41
	1616	1.12		1656	1.42		1858	0.96		1711	1.23		1936	1.11
	2138	4.28		2233	3.74		2339	4.52		2232	4.09		2347	4.67
9 TH	0526	1.50	24 TU	0601	1.57	9 W	0805	1.05	9 TH	0634	1.20	9 SA	0810	0.94
	0953	4.14		1046	3.50		1154	4.32		1059	3.93		1205	4.73
	1742	1.03		1814	1.24		2012	0.80		1849	1.05		2029	1.02
	2244	4.55		2329	4.00					2331	4.42		2300	4.16
10 M	0655	1.31	25 W	0712	1.38	10 TH	0024	4.80	10 F	0749	0.97	10 SA	0017	4.87
	1054	4.37		1140	3.75		0905	0.89		1150	4.30		0652	0.89
	1904	0.90		1922	1.07		1236	4.62		2003	0.89		1232	4.98
	2306	4.84					2108	0.70		2300	4.16		2107	0.97
11 W	0810	1.13	26 TH	0013	4.26	11 SA	0103	5.01	11 M	0013	4.71	11 TU	0040	5.00
	1046	4.63		0812	1.25		0953	0.79		0847	0.83		0922	0.86
	2013	0.79		1218	4.02		1314	4.84		1228	4.63		1256	5.14
				2016	0.95		2151	0.67		2057	0.78		2134	0.94
12 TH	0029	5.09	27 F	0045	4.51	12 SU	0136	5.12	12 M	0045	4.93	12 W	0103	5.06
	0609	0.99		0901	1.14		1029	0.76		0930	0.76		0945	0.83
	0302	4.85		1248	4.29		1349	4.93		1258	4.88		1321	5.21
	0809	0.72		2100	0.85		2225	0.70		2137	0.74		2154	0.92
13 M	0105	5.25	28 SA	0112	4.76	13 M	0209	5.10	13 TU	0045	4.93	13 TH	0128	5.04
	0509	0.91		0939	1.04		1059	0.77		0930	0.76		1005	0.81
	0849	0.97		1315	4.55		1423	4.90		1220	5.06		1347	5.20
	0807	0.72		2138	0.77		2254	0.79		2109	0.71		2215	0.94
14 TH	0138	4.97	29 SU	0138	4.97	14 M	0242	4.99	14 W	0102	5.60	14 SA	0157	4.98
	0309	0.89		1013	0.92		1124	0.81		1005	0.38		1027	0.81
	0849	0.97		1342	4.74		1457	4.78		1319	5.67		1417	5.11
	0807	0.72		2214	0.73		2321	0.90		2225	0.51		2237	0.98
15 M	0207	5.10	30 M	0207	5.10	15 W	0313	4.82	15 TH	0138	5.66	15 SA	0229	4.86
	0409	0.81		1049	0.81		1146	0.84		1042	0.30		1049	0.85
	0845	0.85		1414	4.85		1532	4.62		1356	5.69		1447	4.96
	0809	0.93		2252	0.75		2344	1.00		2302	0.54		2303	1.08
16 TH	0240	5.13	31 TU	0240	5.13				16 W	0219	5.54	16 SA	0244	5.35
	1124	0.74		1124	0.74					1117	0.33		1045	0.48
	1452	4.84		1452	4.84					1440	5.52		1414	5.79
	2331	0.82		2331	0.82					2338	0.88		2315	0.83

MAYAPUR (HUGLI RIVER) - INDIA

LAT. 22° 26' N. LONG. 88° 08' E.

TIME ZONE -0530

TIMES AND HEIGHTS OF HIGH AND LOW WATERS

YE

AUGU

MAY			JUNE			JULY			AUGU				
TIME	Ht.		TIME	Ht.		TIME	Ht.		TIME	Ht.			
h m m	h m m		h m m	h m m		h m m	h m m		h m m	h m m			
1 M	0337 4.94 1150 0.92 1559 4.98	16 TU	0310 4.61 1102 1.32 1526 4.77 2332 1.52	1 TH	0057 1.51 0526 4.43 1256 1.68 1752 4.48	16 F	0414 4.62 1202 1.71 1637 4.80	1 SA	0104 1.63 0542 4.55 1311 1.95 1757 4.49	16 SU	0020 1.46 0437 5.00 1239 1.76 1659 5.01	1 TU	0118 1.88 0643 4.43 1404 2.17 1903 4.17
2 TU	0026 1.25 0437 4.50 1223 1.21 1702 4.54	17 W	0347 4.41 1128 1.48 1607 4.56	2 F	0151 1.59 0637 4.23 1403 1.85 1905 4.28	17 SA	0034 1.60 0508 4.53 1253 1.81 1738 4.65	2 SU	0145 1.73 0645 4.40 1413 2.07 1904 4.28	17 M	0058 1.46 0537 4.89 1331 1.85 1805 4.79	2 W	0237 1.96 0818 4.42 1547 2.09 2045 4.15
3 W	0112 1.44 0550 4.12 1313 1.49 1829 4.21	18 TH	0003 1.61 0432 4.22 1204 1.64 1702 4.37	3 SA	0255 1.62 0754 4.19 1523 1.90 2019 4.21	18 SU	0125 1.57 0618 4.49 1402 1.87 1852 4.57	3 M	0246 1.79 0801 4.38 1532 2.07 2019 4.21	18 TU	0149 1.49 0656 4.83 1443 1.89 1929 4.66	3 TH	0409 1.85 0944 4.63 1713 1.88 2208 4.36
4 TH	0227 1.54 0718 3.92 1442 1.66 2000 4.09	19 F	0050 1.66 0535 4.06 1307 1.78 1819 4.23	4 SU	0400 1.59 0914 4.32 1639 1.84 2131 4.28	19 M	0230 1.51 0742 4.59 1523 1.82 2012 4.63	4 TU	0355 1.76 0920 4.52 1648 1.94 2138 4.30	19 W	0303 1.49 0824 4.94 1611 1.80 2048 4.75	4 F	0526 1.65 1038 4.91 1825 1.67 2301 4.63
5 F	0349 1.48 0851 3.96 1614 1.65 2125 4.17	20 SA	0159 1.64 0703 4.02 1438 1.82 1950 4.27	5 M	0507 1.53 1013 4.56 1752 1.73 2225 4.45	20 TU	0347 1.39 0858 4.87 1649 1.67 2119 4.83	5 W	0504 1.66 1018 4.76 1759 1.77 2234 4.49	20 TH	0428 1.39 0935 5.22 1741 1.61 2157 5.00	5 SA	0634 1.47 1120 5.18 1925 1.53 2340 4.91
6 SA	0506 1.37 1008 4.21 1741 1.55 2226 4.37	21 SU	0323 1.52 0833 4.24 1613 1.71 2104 4.50	6 TU	0610 1.45 1056 4.82 1852 1.60 2306 4.63	21 W	0505 1.23 0956 5.24 1809 1.48 2214 5.12	6 TH	0610 1.52 1103 4.99 1859 1.61 2319 4.70	21 F	0552 1.23 1033 5.56 1904 1.41 2253 5.32	6 SU	0730 1.35 1155 5.41 1925 1.53 2340 4.91
7 SU	0618 1.27 1057 4.52 1851 1.43 2309 4.58	22 M	0444 1.32 0941 4.65 1739 1.51 2202 4.63	7 W	0703 1.35 1130 5.05 1941 1.48 2340 4.80	22 TH	0619 1.06 1045 5.61 1921 1.30 2301 5.42	7 F	0706 1.39 1141 5.20 1951 1.51 2355 4.90	22 SA	0709 1.09 1120 5.87 2010 1.26 2342 5.62	7 M	0011 5.16 0816 1.28 1221 5.62 2053 1.40
8 M	0717 1.19 1133 4.81 1946 1.33 2342 4.77	23 TU	0559 1.10 1031 5.12 1853 1.29 2246 5.19	8 TH	0745 1.26 1202 5.22 2020 1.39	23 F	0726 0.93 1128 5.92 2022 1.17 2346 5.67	8 SA	0751 1.29 1213 5.36 2031 1.45	23 SU	0813 1.00 1203 6.10 2105 1.17	8 TU	0035 5.40 0851 1.23 1244 5.80 2126 1.35
9 TU	0800 1.13 1201 5.05 2027 1.25	24 W	0705 0.90 1111 5.57 1954 1.10 2324 5.51	9 F	0010 4.93 0821 1.18 1229 5.33 2052 1.34	24 SA	0822 0.85 1210 6.12 2114 1.10	9 SU	0026 5.06 0829 1.24 1239 5.48 2105 1.43	24 M	0026 5.84 0905 0.99 1243 6.20 2151 1.15	9 W	0058 5.59 0926 1.22 1306 5.92 2158 1.29
10 W	0008 4.91 0834 1.07 1227 5.21 2056 1.18	25 TH	0801 0.74 1147 5.92 2045 0.96	10 SA	0039 5.02 0849 1.14 1257 5.39 2119 1.32	25 SU	0032 5.80 0912 0.85 1254 6.16 2200 1.11	10 M	0052 5.19 0859 1.23 1305 5.57 2135 1.41	25 TU	0108 5.91 0949 1.06 1323 6.15 2232 1.19	10 TH	0125 5.70 1001 1.25 1336 5.95 2232 1.26
11 TH	0033 5.00 0901 1.02 1252 5.30 2119 1.13	26 F	0001 5.74 0850 0.64 1225 6.12 2132 0.89	11 SU	0108 5.06 0916 1.14 1324 5.39 2146 1.34	26 M	0119 5.78 0958 0.95 1340 6.04 2244 1.18	11 TU	0120 5.26 0931 1.26 1332 5.60 2207 1.42	26 W	0152 5.83 1029 1.21 1405 5.96 2307 1.29	11 F	0158 5.72 1039 1.35 1412 5.87 2306 1.21
12 F	0059 5.03 0923 0.97 1317 5.32 2142 1.12	27 SA	0044 5.81 0935 0.63 1307 6.12 2215 0.92	12 M	0138 5.05 0944 1.20 1353 5.34 2217 1.41	27 TU	0210 5.61 1040 1.12 1429 5.78 2323 1.29	12 W	0150 5.28 1006 1.34 1403 5.57 2242 1.44	27 TH	0235 5.63 1104 1.40 1447 5.68 2337 1.40	12 SA	0237 5.6 1117 1.4 1453 5.7 2337 1.2
13 SA	0128 5.01 0946 0.97 1345 5.26 2207 1.16	28 SU	0132 5.70 1017 0.73 1356 5.93 2256 1.04	13 TU	0212 4.97 1017 1.31 1427 5.23 2250 1.49	28 W	0303 5.34 1120 1.35 1520 5.44	13 TH	0225 5.24 1044 1.46 1440 5.48 2316 1.47	28 F	0320 5.36 1135 1.59 1529 5.37	13 SU	0320 5.1 1151 1.1 1538 5.
14 SU	0200 4.94 1011 1.03 1418 5.15 2234 1.25	29 M	0226 5.44 1056 0.93 1447 5.60 2336 1.20	14 W	0248 4.85 1049 1.46 1505 5.09 2324 1.57	29 TH	0001 1.42 0354 5.05 1157 1.57 1611 5.10	14 F	0304 5.16 1122 1.58 1521 5.36 2348 1.47	29 SA	0003 1.51 0400 5.12 1201 1.76 1608 5.06	14 M	0004 1. 0406 5. 1225 1. 1626 5.
15 M	0235 4.80 1037 1.16 1451 4.97 2304 1.39	30 TU	0321 5.09 1133 1.18 1543 5.19	15 TH	0327 4.73 1123 1.60 1546 4.95 2356 1.60	30 F	0033 1.53 0446 4.77 1232 1.77 1701 4.77	15 SA	0348 5.08 1159 1.68 1607 5.20	30 SU	0021 1.61 0442 4.87 1225 1.91 1649 4.74	15 TU	0033 1. 0501 1. 1307 1. 1726 .
		31	0015 1.37						31	0042 1.73 0530 4.63 1258 2.06			

GARDEN REACH (HUGLI RIVER) – INDIA

LAT. 22° 33' N. LONG. 88° 18' E.

TIME ZONE -0530

TIMES AND HEIGHTS OF HIGH AND LOW WATERS

JANUARY			FEBRUARY			MARCH							
TIME	Ht.		TIME	Ht.		TIME	Ht.		TIME				
h m m		h m m	h m m		h m m	h m m		h m m	h m m				
1 SU	0315 5.01 1159 1.60 1523 4.61	16 M	0019 1.44 0406 5.11 1253 1.49 1618 4.72	1 W	0042 1.34 0411 5.15 1306 1.20 1628 4.84	16 TH	0055 1.52 0431 4.75 1312 1.37 1648 4.56	1 W	0310 5.51 1220 0.95 1527 5.34	16 TH	0002 1.40 0329 4.96 1221 1.27 1545 4.96	1 SA	0051 0359 1301 1622
2 M	0002 1.52 0348 4.98 1233 1.59 1601 4.57	17 TU	0051 1.58 0438 4.88 1318 1.54 1652 4.52	2 TH	0120 1.42 0450 5.00 1337 1.17 1711 4.70	17 F	0117 1.59 0458 4.50 1328 1.39 1718 4.33	2 TH	0035 1.15 0346 5.42 1253 0.94 1605 5.24	17 F	0025 1.44 0353 4.82 1240 1.28 1610 4.79	2 SU	0125 0443 1337 1705
3 TU	0040 1.62 0426 4.90 1306 1.56 1643 4.50	18 W	0119 1.70 0507 4.63 1339 1.56 1726 4.31	3 F	0157 1.51 0534 4.76 1407 1.17 1800 4.52	18 SA	0137 1.68 0528 4.20 1343 1.47 1758 4.04	3 F	0110 1.26 0424 5.19 1324 0.98 1646 5.02	18 SA	0047 1.50 0420 4.60 1257 1.33 1638 4.56	3 M	0151 0537 1407 1807
4 W	0118 1.70 0509 4.78 1340 1.50 1732 4.42	19 TH	0143 1.80 0538 4.34 1358 1.59 1805 4.08	4 SA	0235 1.61 0624 4.45 1444 1.22 1859 4.27	19 SU	0202 1.80 0608 3.85 1409 1.60 1855 3.73	4 SA	0145 1.38 0506 4.87 1351 1.06 1730 4.72	19 SU	0108 1.59 0450 5.34 1312 1.42 1712 4.28	4 TU	024 064 145 193
5 TH	0200 1.76 0558 4.61 1418 1.43 1829 4.31	20 F	0210 1.90 0617 4.03 1422 1.65 1859 3.84	5 SU	0324 1.73 0730 4.09 1537 1.34 2027 4.08	20 M	0244 1.93 0708 3.48 1504 1.73 2043 3.54	5 SU	0217 1.52 0555 4.46 1422 1.21 1826 4.35	20 M	0128 1.71 0525 4.03 1327 1.55 1757 3.96	5 W	040 082 162 212
6 F	0248 1.83 0654 4.39 1506 1.42 1937 4.20	21 SA	0247 2.02 0714 3.69 1506 1.74 2019 3.65	6 M	0438 1.82 0903 3.84 1701 1.43 2206 4.11	21 TU	0416 1.99 0905 3.26 1658 1.72 2232 3.64	6 M	0300 1.68 0700 4.02 1511 1.40 1957 4.03	21 TU	0158 1.83 0613 3.68 1405 1.71 1913 3.68	6 TH	054 107 187 227
7 SA	0350 1.90 0808 4.17 1611 1.43 2103 4.19	22 SU	0356 2.09 0840 3.43 1630 1.77 2157 3.66	7 TU	0621 1.75 1036 3.86 1839 1.39 2327 4.35	22 W	0615 1.81 1101 3.36 1836 1.55 2344 3.93	7 TU	0417 1.79 0844 3.71 1641 1.55 2149 3.99	22 W	0306 1.93 0741 3.38 1541 1.82 2122 3.64	7 F	07 11 19 23
8 SU	0510 1.90 0931 4.08 1731 1.42 2225 4.36	23 M	0541 1.98 1020 3.39 1804 1.64 2321 3.86	8 W	0759 1.55 1152 4.08 2011 1.28	23 TH	0740 1.59 1205 3.65 1955 1.38	8 W	0609 1.69 1030 3.74 1828 1.49 2321 4.23	23 TH	0508 1.86 0956 3.39 1742 1.72 2251 3.90	8 SA	08 12 20
9 M	0639 1.79 1046 4.18 1856 1.35 2331 4.63	24 TU	0705 1.77 1142 3.55 1920 1.47	9 TH	0029 4.65 0912 1.36 1248 4.37 2122 1.19	24 F	0031 4.25 0846 1.45 1247 3.99 2100 1.28	9 TH	0747 1.45 1150 4.02 2002 1.34	24 F	0648 1.63 1121 3.70 1913 1.54 2347 4.26	9 SU	09 13 27
10 TU	0806 1.63 1149 4.38 2016 1.26	25 W	0017 4.11 0815 1.59 1234 3.78 2026 1.34	10 F	0118 4.92 1011 1.27 1335 4.65 2216 1.16	25 SA	0107 4.58 0941 1.35 1319 4.37 2153 1.22	10 F	0021 4.54 0857 1.26 1244 4.35 2113 1.24	25 SA	0805 1.44 1209 4.12 2028 1.41	10 M	07 10 16 21
11 W	0028 4.91 0917 1.48 1243 4.62 2123 1.20	26 TH	0100 4.36 0915 1.50 1311 4.03 2121 1.28	11 SA	0201 5.12 1058 1.24 1416 4.86 2259 1.18	26 SU	0138 4.92 1028 1.26 1350 4.75 2236 1.16	11 SA	0107 4.82 0954 1.19 1325 4.66 2205 1.23	26 SU	0027 4.65 0905 1.29 1245 4.58 2127 1.30	11 TU	0 1 1 2
12 TH	0118 5.15 1015 1.39 1333 4.82 2218 1.18	27 F	0135 4.59 1003 1.46 1342 4.29 2206 1.24	12 SU	0239 5.23 1136 1.26 1452 4.97 2333 1.25	27 M	0208 5.23 1107 1.14 1420 5.08 2316 1.10	12 SU	0143 5.03 1038 1.20 1400 4.90 2246 1.25	27 M	0100 5.05 0956 1.16 1319 5.04 2216 1.19	12 W	0 1 1 2
13 F	0206 5.30 1104 1.36 1419 4.95 2303 1.21	28 SA	0205 4.83 1045 1.42 1411 4.55 2245 1.22	13 M	0312 5.22 1206 1.30 1524 4.98	28 TU	0238 5.44 1144 1.03 1452 5.29 2355 1.10	13 M	0214 5.14 1111 1.23 1430 5.05 2315 1.30	28 TU	0131 5.40 1037 1.01 1353 5.43 2258 1.10	13 TH	0 1 1 2
14 SA	0250 5.34 1146 1.38 1502 4.97 2343 1.31	29 SU	0234 5.04 1122 1.36 1439 4.76 2325 1.22	14 TU	0003 1.35 0340 5.12 1232 1.34 1553 4.89	29 W	0003 1.35 0340 5.12 1232 1.34 1553 4.89	14 TU	0241 5.16 1138 1.26 1458 5.10 2339 1.35	29 W	0204 5.64 1117 0.88 1427 5.67 2337 1.05	14 F	0 1 1 2
15 SU	0330 5.27 1223 1.43 1542 4.89	30 M	0303 5.18 1157 1.29 1512 4.89	15 W	0030 1.44 0406 4.95 1254 1.36 1619 4.75	30 W	0030 1.44 0406 4.95 1254 1.36 1619 4.75	15 W	0305 5.10 1200 1.27 1522 5.07	30 TH	0239 5.71 1153 0.82 1504 5.72	15 SA	0 1 1 2
		31	0003 1.26							31	0015 1.10 0918 5.59		

GARDEN REACH (HUGLI RIVER) – INDIA

149

LAT. 22° 33' N. LONG. 88° 18' E.

YEAR 2017

TIME ZONE -0530

TIMES AND HEIGHTS OF HIGH AND LOW WATERS

AUGUST

MAY

JUNE

JULY

MAY		JUNE		JULY		AUGUST									
TIME	Ht.	TIME	Ht.	TIME	Ht.	TIME	Ht.								
h m	m	h m	m	h m	m	h m	m								
1 M	0105 1.51 0426 4.96 1310 1.36 1649 5.04	16 TU	0016 1.79 0356 4.59 1221 1.70 1615 4.80	1 TH	0210 1.91 0606 4.55 1418 2.05 1833 4.64	16 F	0106 2.03 0501 4.75 1319 2.13 1726 4.98	1 SA	0217 2.15 0618 4.81 1430 2.44 1838 4.77	16 SU	0132 2.07 0523 5.27 1357 2.36 1746 5.31	1 TU	0233 2.50 0722 4.79 1519 2.77 1949 4.52	16 W	0238 2.22 0700 5.28 1534 2.60 1944 4.99
2 TU	0142 1.88 0520 4.54 1346 1.60 1747 4.62	17 W	0043 1.87 0436 4.42 1245 1.82 1657 4.63	2 F	0304 1.93 0717 4.35 1523 2.17 1947 4.42	17 SA	0147 1.98 0559 4.69 1410 2.20 1828 4.85	2 SU	0258 2.19 0723 4.65 1530 2.52 1946 4.53	17 M	0212 2.03 0624 5.18 1450 2.41 1851 5.11	2 W	0352 2.52 0902 4.78 1701 2.64 2134 4.50	17 TH	0355 2.28 0847 5.26 1713 2.51 2123 5.01
3 W	0228 1.79 0633 4.17 1436 1.80 1913 4.30	18 TH	0115 1.91 0524 4.26 1321 1.93 1754 4.46	3 SA	0409 1.90 0834 4.30 1641 2.18 2105 4.33	18 SU	0238 1.92 0709 4.67 1517 2.24 1943 4.77	3 M	0359 2.21 0841 4.62 1647 2.48 2106 4.44	18 TU	0306 2.02 0744 5.13 1600 2.42 2016 4.99	3 TH	0523 2.37 0902 4.99 1822 2.39 2259 4.70	18 F	0534 2.20 1014 5.50 1849 2.28 2243 5.27
4 TH	0343 1.80 0801 3.97 1604 1.91 2046 4.17	19 F	0202 1.91 0629 4.13 1423 2.04 1912 4.34	4 SU	0513 1.84 0959 4.42 1754 2.11 2222 4.37	19 M	0347 1.85 0833 4.77 1639 2.20 2103 4.81	4 TU	0507 2.15 1007 4.75 1801 2.34 2228 4.51	19 W	0423 2.00 0911 5.26 1729 2.32 2137 5.07	4 F	0637 2.16 1128 5.26 1931 2.19 2351 4.95	19 SA	0705 2.03 1121 5.84 2009 2.07 2344 5.62
5 F	0504 1.69 0937 4.01 1731 1.85 2214 4.23	20 SA	0312 1.86 0755 4.11 1552 2.07 2041 4.37	5 M	0619 1.78 1103 4.65 1903 2.01 2319 4.51	20 TU	0503 1.74 0948 5.04 1802 2.06 2208 5.00	5 W	0617 2.04 1109 4.99 1908 2.16 2327 4.89	20 TH	0548 1.90 1023 5.54 1856 2.15 2246 5.30	5 SA	0742 2.01 1211 5.51 2029 2.09	20 SU	0822 1.91 1212 6.17 2114 1.96
6 SA	0620 1.55 1056 4.24 1853 1.76 2318 4.39	21 SU	0436 1.74 0925 4.32 1725 1.97 2155 4.57	6 TU	0720 1.72 1149 4.90 2001 1.90	21 W	0622 1.62 1048 5.40 1922 1.90 2303 5.27	6 TH	0719 1.91 1156 5.23 2006 2.02	21 F	0709 1.79 1123 5.86 2014 1.99 2343 5.59	6 SU	0029 5.20 0839 1.95 1245 5.73 2120 2.08	21 M	0032 5.95 0924 1.88 1255 6.40 2206 1.94
7 SU	0729 1.47 1148 4.53 2001 1.68	22 M	0558 1.58 1032 4.70 1849 1.82 2252 4.88	7 W	0003 4.68 0813 1.67 1228 5.13 2050 1.82	22 TH	0733 1.50 1140 5.76 2032 1.77 2354 5.55	7 F	0012 4.90 0816 1.82 1236 5.42 2057 1.96	22 SA	0823 1.70 1216 6.16 2120 1.90	7 M	0059 5.45 0925 1.94 1315 5.93 2202 2.10	22 TU	0113 6.21 1012 1.91 1332 6.53 2250 1.99
8 M	0005 4.58 0825 1.45 1229 4.80 2054 1.64	23 TU	0712 1.41 1122 5.15 2004 1.65 2336 5.21	8 TH	0038 4.85 0857 1.62 1302 5.30 2132 1.78	23 F	0838 1.41 1228 6.05 2133 1.68	8 SA	0048 5.09 0903 1.77 1310 5.57 2141 1.95	23 SU	0034 5.88 0924 1.67 1304 6.38 2215 1.87	8 TU	0124 5.68 1003 1.97 1339 6.10 2236 2.11	23 W	0151 6.35 1052 2.01 1408 6.52 2325 2.07
9 TU	0039 4.75 0911 1.45 1302 5.03 2136 1.62	24 W	0817 1.27 1208 5.56 2105 1.51	9 F	0109 4.98 0934 1.58 1333 5.40 2206 1.76	24 SA	0043 5.79 0935 1.38 1316 6.25 2225 1.66	9 SU	0117 5.25 0940 1.78 1338 5.68 2217 1.99	24 M	0121 6.09 1015 1.71 1349 6.48 2301 1.90	9 W	0149 5.88 1038 2.00 1405 6.22 2310 2.11	24 TH	0227 6.35 1124 2.14 1440 6.39 2353 2.18
10 W	0108 4.89 0946 1.44 1332 5.20 2210 1.59	25 TH	0018 5.52 0913 1.16 1252 5.91 2157 1.41	10 SA	0135 5.07 1005 1.57 1400 5.45 2235 1.78	25 SU	0130 5.92 1025 1.41 1403 6.30 2312 1.70	10 M	0144 5.38 1014 1.81 1403 5.77 2248 2.03	25 TU	0206 6.18 1100 1.82 1431 6.45 2341 1.98	10 TH	0217 6.01 1115 2.07 1434 6.25 2344 2.10	25 F	0259 6.24 1154 2.29 1508 6.17
11 TH	0134 4.98 1014 1.42 1359 5.29 2236 1.57	26 F	0101 5.74 1003 1.09 1335 6.11 2244 1.38	11 SU	0201 5.12 1032 1.60 1425 5.45 2302 1.83	26 M	0219 5.92 1110 1.53 1449 6.21 2354 1.80	11 TU	0210 5.46 1046 1.88 1430 5.81 2321 2.07	26 W	0248 6.14 1139 1.98 1509 6.29	11 F	0249 6.04 1153 2.16 1506 6.19	26 SA	0019 2.27 0328 6.05 1221 2.42 1535 5.90
12 F	0159 5.01 1039 1.39 1423 5.30 2259 1.57	27 SA	0146 5.83 1047 1.10 1420 6.14 2327 1.43	12 M	0229 5.10 1102 1.67 1451 5.40 2332 1.90	27 TU	0306 5.79 1154 1.72 1533 5.99	12 W	0239 5.49 1122 1.98 1459 5.80 2354 2.11	27 TH	0017 2.09 0326 5.98 1216 2.17 1544 6.04	12 SA	0018 2.11 0325 5.99 1231 2.27 1543 6.05	27 SU	0039 2.35 0356 5.81 1243 2.52 1602 5.61
13 SA	0223 4.99 1103 1.40 1447 5.24 2324 1.61	28 SU	0233 5.74 1130 1.22 1504 5.98	13 TU	0300 5.03 1134 1.79 1521 5.32	28 W	0034 1.91 0353 5.56 1234 1.94 1615 5.70	13 TH	0312 5.47 1200 2.11 1533 5.73	28 F	0047 2.19 0402 5.75 1249 2.35 1616 5.74	13 SU	0048 2.11 0404 5.88 1307 2.36 1624 5.84	28 M	0055 2.41 0424 5.55 1304 2.61 1634 5.29
14 SU	0250 4.90 1128 1.46 1513 5.13 2350 1.69	29 M	0008 1.56 0320 5.50 1212 1.42 1549 5.68	14 W	0003 1.98 0335 4.93 1207 1.93 1554 5.21	29 TH	0110 2.02 0438 5.29 1313 2.14 1656 5.38	14 F	0028 2.13 0350 5.41 1237 2.22 1610 5.63	29 SA	0112 2.27 0438 5.51 1316 2.49 1648 5.43	14 M	0117 2.11 0449 5.72 1343 2.45 1710 5.57	29 TU	0111 2.49 0501 5.24 1328 2.72 1714 4.92
15 M	0322 4.76 1156 1.57 1541 4.97	30 TU	0049 1.71 0411 5.17 1252 1.65 1636 5.32	15 TH	0034 2.04 0415 4.83 1240 2.05 1637 5.10	30 F	0143 2.10 0524 5.03 1350 2.31 1742 5.06	15 SA	0059 2.11 0433 5.35 1315 2.30 1655 5.49	30 SU	0133 2.34 0516 5.25 1342 2.61 1727 5.11	15 TU	0151 2.14 0543 5.50 1427 2.54 1811 5.25	30 W	0135 2.62 0557 4.90 1411 2.83 1820 4.56
		31 W	0127 1.84 0504 4.84 1331 1.87										31 TH	0232 2.74 0754 4.69 1550 2.84 2035 4.39	

LAT. 22° 33' N. LONG. 88° 18' E.

TIME ZONE -0530

TIMES AND HEIGHTS OF HIGH AND LOW WATERS

SEPTEMBER			OCTOBER			NOVEMBER					
TIME	Ht.		TIME	Ht.		TIME	Ht.				
h m	m		h m	m		h m	m				
1 F	0432 2.66 0950 4.82 1742 2.56 2231 4.58	16 SA	0534 2.37 1015 5.29 1845 2.22 2250 5.15	1 SU	0523 2.57 1017 4.78 1816 2.33 2254 4.65	16 M	0656 2.16 1113 5.19 1938 1.85 2340 5.23	1 W	0714 2.15 1114 4.99 1937 1.82 2340 5.16	16 TH	0009 4.99 0836 1.97 1220 4.86 2049 1.75
2 SA	0602 2.40 1058 5.13 1857 2.29 2327 4.89	17 SU	0706 2.15 1121 5.64 2000 1.99 2345 5.53	2 M	0644 2.31 1110 5.12 1923 2.11 2335 5.04	17 TU	0807 2.03 1158 5.43 2038 1.80	2 TH	0819 1.98 1151 5.32 2033 1.68	17 F	0045 5.19 0922 1.93 1252 4.96 2130 1.77
3 SU	0714 2.18 1144 5.44 2000 2.14	18 M	0820 2.00 1207 5.95 2102 1.89	3 TU	0751 2.14 1148 5.46 2022 1.99	18 W	0021 5.53 0904 1.99 1234 5.60 2125 1.84	3 F	0018 5.58 0913 1.84 1225 5.63 2122 1.56	18 SA	0118 5.34 0958 1.90 1320 5.03 2202 1.77
4 M	0006 5.22 0818 2.07 1219 5.73 2056 2.09	19 TU	0028 5.87 0919 1.97 1244 6.17 2151 1.91	4 W	0009 5.44 0849 2.04 1218 5.78 2112 1.91	19 TH	0056 5.75 0948 2.01 1303 5.70 2203 1.91	4 SA	0055 5.95 0959 1.73 1259 5.87 2208 1.46	19 SU	0149 5.41 1028 1.88 1348 5.04 2228 1.75
5 TU	0035 5.54 0910 2.03 1248 6.00 2142 2.07	20 W	0105 6.12 1005 2.01 1316 6.28 2229 1.98	5 TH	0039 5.84 0937 1.96 1246 6.07 2155 1.83	20 F	0127 5.89 1021 2.04 1330 5.72 2231 1.95	5 SU	0132 6.21 1042 1.67 1337 5.98 2249 1.42	20 M	0216 5.41 1053 1.87 1414 4.96 2253 1.74
6 W	0102 5.87 0953 2.02 1313 6.24 2220 2.04	21 TH	0138 6.27 1039 2.08 1346 6.28 2300 2.07	6 F	0110 6.20 1018 1.90 1315 6.29 2233 1.74	21 SA	0156 5.94 1046 2.06 1355 5.66 2254 1.98	6 M	0212 6.29 1122 1.67 1418 5.92 2328 1.47	21 TU	0242 5.34 1116 1.8 1442 4.8 2318 1.7
7 TH	0126 6.17 1031 2.01 1339 6.42 2256 1.98	22 F	0209 6.30 1106 2.17 1413 6.17 2324 2.14	7 SA	0142 6.45 1055 1.86 1348 6.37 2310 1.69	22 SU	0223 5.90 1109 2.08 1421 5.54 2316 2.00	7 TU	0251 6.18 1200 1.77 1504 5.68	22 W	0307 5.2 1141 1.9 1513 4.7 2345 1.8
8 F	0157 6.38 1107 2.02 1408 6.49 2329 1.95	23 SA	0236 6.22 1131 2.25 1439 5.98 2346 2.20	8 SU	0217 6.54 1132 1.89 1425 6.29 2346 1.72	23 M	0247 5.78 1130 2.12 1446 5.36 2339 2.05	8 W	0008 1.62 0333 5.88 1240 1.92 1552 5.31	23 TH	0336 5.1 1208 2.1 1547 4.
9 SA	0229 6.45 1145 2.07 1441 6.41	24 SU	0302 6.06 1153 2.32 1504 5.75	9 M	0254 6.43 1209 1.99 1505 6.04	24 TU	0310 5.59 1153 2.18 1516 5.14	9 TH	0046 1.84 0418 5.48 1319 2.07 1647 4.89	24 F	0012 2. 0407 4. 1237 2 1624 4
10 SU	0004 1.95 0304 6.38 1221 2.18 1519 6.20	25 M	0006 2.26 0326 5.84 1214 2.40 1532 5.49	10 TU	0020 1.83 0331 6.15 1245 2.15 1549 5.87	25 W	0001 2.13 0336 5.34 1216 2.28 1549 4.88	10 F	0126 2.07 0513 5.03 1405 2.18 1756 4.50	25 SA	0040 2 0446 4 1308 2 1710 4
11 M	0035 2.01 0341 6.18 1255 2.31 1559 5.90	26 TU	0024 2.33 0352 5.57 1235 2.49 1603 5.19	11 W	0053 1.99 0413 5.76 1321 2.31 1640 5.23	26 TH	0021 2.25 0408 5.06 1239 2.38 1625 4.60	11 SA	0216 2.28 0632 4.64 1513 2.20 1926 4.26	26 SU	0115 2. 0536 4. 1350 2 1610 2
12 TU	0104 2.09 0424 5.89 1329 2.44 1647 5.53	27 W	0039 2.43 0423 5.25 1257 2.60 1638 4.85	12 TH	0126 2.20 0506 5.31 1403 2.46 1747 4.78	27 F	0041 2.39 0446 4.75 1310 2.48 1714 4.32	12 SU	0337 2.39 0807 4.43 1637 2.06 2101 4.26	27 M	0209 0646 1449 1932
13 W	0134 2.21 0515 5.53 1410 2.57 1748 5.11	28 TH	0058 2.57 0505 4.89 1329 2.72 1729 4.49	13 F	0215 2.41 0629 4.88 1517 2.52 1934 4.50	28 SA	0114 2.54 0548 4.45 1404 2.53 1828 4.07	13 M	0508 2.30 0938 4.44 1749 1.89 2225 4.46	28 TU	0328 0814 1606 2103
14 TH	0220 2.37 0634 5.16 1518 2.66 1933 4.79	29 F	0138 2.73 0624 4.56 1439 2.79 1916 4.21	14 SA	0344 2.53 0829 4.74 1703 2.33 2123 4.56	29 SU	0228 2.66 0734 4.27 1535 2.47 2030 4.04	14 TU	0627 2.15 1050 4.57 1900 1.77 2324 4.74	29 W	0458 0934 1728 2217
15 F	0344 2.49 0838 5.05 1710 2.53 2124 4.83	30 SA	0319 2.80 0851 4.52 1651 2.62 2141 4.31	15 SU	0530 2.38 1006 4.91 1826 2.05 2246 4.88	30 M	0422 2.60 0919 4.38 1714 2.24 2202 4.32	15 W	0738 2.03 1141 4.72 2001 1.74	30 TH	0624 1034 1844 2314
						31 TU	0557 2.37 1027 4.66 1832 2.00				

Annexure 12: Schedule IV of Ministry of Shipping Notification dated 13 July 2016

This page has been intentionally left blank. Please turn over to next page.



भारत का राजपत्र

The Gazette of India

असाधारण

EXTRAORDINARY

भाग II—खण्ड 3—उप-खण्ड (i)

PART II—Section 3—Sub-section (i)

प्राधिकार से प्रकाशित

PUBLISHED BY AUTHORITY

सं. 480]

नई दिल्ली, बुधवार, जुलाई 13, 2016/आसाध 22, 1938

No. 480]

NEW DELHI, WEDNESDAY, JULY 13, 2016/ASADHA 22, 1938

पोत परिवहन मंत्रालय

अधिसूचना

नई दिल्ली, 13 जुलाई, 2016

सा.का.नि. 687(अ).—अंतर्देशीय जलयान (प्रदूषण का निवारण और नियंत्रण और अंतर्देशीय जल का संरक्षण) नियम, 2016 को अंतर्देशीय जलयान अधिनियम, 1917 (1917 का 1) की धारा 54ज द्वारा प्रदत्त शक्तियों का प्रयोग करते हुए उक्त अधिनियम की धारा 74 की उपधारा (1) द्वारा यथाअपेक्षित उस तारीख से जब राजपत्र में यथाप्रकाशित अधिसूचना की प्रतियां आम जनता को उपलब्ध कराई गई थी, तीस दिन की अवधि की समाप्ति से पूर्व आक्षेप और सुझाव आमंत्रित करने के लिए भारत के राजपत्र, असाधारण, भाग II, खंड 3, उपखंड (i) तारीख 3 फरवरी, 2016, सा.का.नि. 144(अ) तारीख 3 फरवरी, 2016 द्वारा प्रकाशित किया गया था।

उक्त अधिसूचना 3 फरवरी, 2016 को आम जनता के लिए उपलब्ध कराई गई थी;

उक्त प्रारूप नियमों के संबंध में प्राप्त आक्षेपों और सुझावों पर केंद्रीय सरकार द्वारा विचार किया गया है;

अतः केंद्रीय सरकार, अंतर्देशीय जलयान अधिनियम, 1917 की धारा 54ज द्वारा प्रदत्त शक्तियों का प्रयोग करते हुए निम्नलिखित नियम बनाती है, अर्थात् :-

1. संक्षिप्त नाम और प्रारंभ – (1) इन नियमों का संक्षिप्त नाम अंतर्देशीय जलयान (प्रदूषण का निवारण और नियंत्रण और अंतर्देशीय जल का संरक्षण) नियम, 2016 है।

(2) ये राजपत्र में प्रकाशन की तारीख को प्रवृत्त होंगे।

2. परिभाषाएं— (1) इन नियमों में, जब तक कि संदर्भ से अन्यथा अपेक्षित न हों :

(क) “अधिनियम” से अंतर्देशीय जलयान अधिनियम, 1917 अभिप्रेत है;

(ख) “कोई व्यक्ति” से अधिनियम की धारा 54छ के अधीन प्राधिकृत कोई व्यक्ति अभिप्रेत है, जिसके अंतर्गत अधिनियम की धारा 4 की उपधारा (1) के अधीन नियुक्त कोई सर्वेक्षक है ;

(ग) “नितल जल” से जलयान के नितल में संगृहीत अपशिष्ट जल अभिप्रेत है;

(घ) “धारक टैंक” से ऐसा टैंक अभिप्रेत है जिसका उपयोग तेलीय मिश्रण या नितल जल या रसायनिकों और घृणाजनक पदार्थों के गंदे या धुलाई पूर्व जल के संग्रहण और भंडारण के लिए किया जाता है ;

(ड.) “अंतर्देशीय पत्तन” से ऐसा पत्तन अभिप्रेत है जिसमें अंतर्देशीय जलमार्ग पर जलयानों को सुरक्षित घाट पर लगाने, स्थौरा को लादने और उतारने की व्यवस्था, भूमि पर स्थौरा के भंडारण और जल आपूर्ति तथा इंधन की व्यवस्था करने के लिए अपेक्षित सुविधाएं हों;

(च) “अनुसूची” से इन नियमों से उपाबद्ध अनुसूची अभिप्रेत है;

(छ) “गंदा जल” से ऐसा गंदा जल अभिप्रेत है जो इंधन या स्नेहक तेल और पृथक्कारक, मुख्य सहायक मशीनरी से अपशिष्ट स्नेहक तेल, या नितल जल पृथक्कारक, तेल फिल्टर उपस्कर या ड्रिप ट्रे से अपशिष्ट तेल है ;

(2) इन नियमों में प्रयुक्त शब्द और पद जो परिभाषित नहीं किए गए हैं परंतु अधिनियम में परिभाषित हैं के वही अर्थ होंगे जो उनके अधिनियम में हैं ।

3. अनुसूची – 1 में विनिर्दिष्ट रसायनिक और पदार्थ धारा 54 घ के खंड (क) के प्रयोजन के लिए परिसंकटमय रसायनिक और घृणाजनक पदार्थ होंगे ।

4. अंतर्देशीय जल को संरक्षित करने के लिए प्रदूषण को निवारित और नियंत्रित करने के उपाय — इन नियमों के परिवर्तित होने की तारीख से एक वर्ष के भीतर अनुसूची 2 में यथाविनिर्दिष्ट प्रत्येक अंतर्देशीय पत्तन तट पर तेलीय मिश्रण उपचार उपस्कर की व्यवस्था करेगा ।

5. इन नियमों के परिवर्तित होने की तारीख से एक वर्ष के भीतर अनुसूची 3 के भाग 1 में यथाविनिर्दिष्ट प्रत्येक अंतर्देशीय जलयान जो 1000 सकल टन से अधिक हो पर ऑन बोर्ड तेलीय मिश्रण उपचार उपस्कर की व्यवस्था होगी ।

6. एक अंतर्देशीय जलयान में अनुसूची 3 के भाग 2 में यथाविनिर्दिष्ट धारक टैंक या क्षमता की कोई समान व्यवस्था होगी ।

7. प्रत्येक अंतर्देशीय पत्तन इन नियमों की प्रवर्तित होने की तारीख से एक वर्ष के भीतर अनुसूची 4 में विनिर्दिष्ट जलयान को अयुक्तियुक्त ढंग से विलंबित किए बिना 24 घंटों के आधार पर कार्यों की प्रकृति पूर्व आधारित स्वागत सुविधाओं की व्यवस्था करेगा ।

8. अंतर्देशीय पत्तन स्थौरा या यात्री टर्मिनल पर अनुसूची 5 में यथाविनिर्दिष्ट प्ररूप और अभिलेख पुस्तकें अनुरक्षित करेगा ।

9. इन नियमों के प्रवर्तन में आने के एक वर्ष के पश्चात् किसी भी समय अधिनियम की धारा 54छ के अधीन सर्वेक्षक या राज्य सरकार द्वारा इस निमित्त किसी व्यक्ति द्वारा निरीक्षण किया जाएगा और निम्नलिखित कार्रवाई की जाएगी, --

- (i) यदि यह पाया गया है कि अंतर्देशीय पत्तन में प्रदूषण नियंत्रण उपस्कर और केंद्रीय सरकार द्वारा अध्याय 6 कख के अधीन बनाए गए नियमों, अधिनियम की धारा 54च के अधीन या राज्य सरकार के आदेशों के अनुरूप हटाने वाली सामग्री है, तो अनुसूची 8 में विहित प्ररूप में अनुपालन या अनुरूपता का प्रमाणपत्र जारी किया जाएगा ।
- (ii) यदि सर्वेक्षक द्वारा यह पाया जाता है कि अंतर्देशीय पत्तन में प्रदूषण नियंत्रण उपस्कर और अधिनियम की धारा 54छ के अधीन या केंद्रीय सरकार द्वारा अध्याय 6कख के अधीन जारी किए गए नियमों के अधीन राज्य सरकार के आदेशों के अनुरूप हटाने वाली सामग्री की व्यवस्था नहीं की गई है, तो अनुसूची 6 में यथाविहित प्ररूप में कमियों को दर्शाने वाला और अंतर्देशीय पत्तन के स्वामी को सुधारात्मक कार्रवाई करने के लिए निदेश देते हुए एक नोटिस जारी करेगा और नोटिस की प्राप्ति की तारीख से 30 दिन की अवधि के भीतर अनुपालन की रिपोर्ट करेगा ।
- (iii) अनुपालन रिपोर्ट किए जाने के पश्चात् और सर्वेक्षण का समाधान होने पर, अनुपालन या अनुरूपता का प्रमाणपत्र अनुसूची 7 में विनिर्दिष्ट प्ररूप में जारी किया जाएगा ।

अनुसूची – 1

(नियम 3 देखें)

ढेर में या पैकेज रूप में, जिसके अंतर्गत अपशिष्ट हैं, परिसंकटमय रसायनिकों या घृणाजनक पदार्थों की सूची

परिसंकटमय रसायन अथवा घृणाजनक पदार्थ

एसीटिक एनहाइड्राइड

एसीटोन

एसीटोन साईनोहाईड्रिन

एक्रोलिन

एक्रीलोनोईट्राइल

एल्डिन

एलिलसोथियोसायनेट

एल्युमिनियम फास्फाइड
 अमोनिया (28%आकुएऔस)
 अमोनियम फास्फेट
 एमिल मरकेप्टन
 एनीलीन
 एनीलीन हाईड्रोक्लोराइड
 एंटीमनी कंपाउंड
 एट्राजीन
 एजीनफॉसमिथाइल (गुथाईन)
 बेईयम एजाइड
 बेरियमऑक्साइड
 बेंजीन
 बेंजीनहेक्साक्लोराइड आईसोमर्स (लिडेन)
 बेंजीडाईन
 बेरीलियम पाउडर
 ब्रोमीन
 ब्रोमोबेंजिल सायनाइड
 एन-ब्यूटिल एक्रीलेट
 ब्यूटाईरिक एसिड
 केकोडिलिक कम्पाउंड्स
 कोबैरिल (सेविन)
 कार्बनडाईसल्फाइड
 कार्बनटेट्राक्लोराइड
 क्लोरीडेन
 क्लोरोसीटोफीनोन
 क्लोरोडाईनाईट्रोबेंजीन
 क्लोरोफार्म
 क्लोरोहाईड्रीन्स (कूड)
 क्लोरो पिक्निन
 क्रोमिक एसिड (क्रोमियम ट्राईआक्साइड)
 कोकूलस (ठोस)
 कॉपर कम्पाउंड्स
 क्रीसोल्स
 क्यूप्रीएथीलीन डाईएमीन
 साइनाइड कम्पाउंड्स
 सायनोजन
 सायनोजिनक्लोराइड
 डीओटी
 डायक्लोरोएनीलीज
 डायक्लोरोबेंजीन
 डाईएल्ड्रीन
 डायमीथोएट (साइगोन)

डायमेथिल एमीन (40%आकुएऔस)
 डाईनाइट्रोएनीलीन्स
 4.6-डाईनाइट्रोओथ्रोक्रीसोल्स
 डायनाइट्रोफीनोल्स
 एन्डोसल्फान (थायोडान)
 एन्ड्रीन
 एपीक्लोरोहाईड्रीन्स
 एथिलब्रोमोएसीटेट
 एथीलीन क्लोरोहाईड्रीन (2-क्लोरो-एथेनॉल)
 एथिल पैराथिओन
 फैंटीन एसीटेट (सूखा)
 फ्लुओसिलिसिक एसिड
 हेप्टाक्लोर
 हेक्साक्लोरोबेंजीन
 हेक्जाएथिल टेट्राफास्फेट
 हाईड्रोसाइनिक एसिड
 हाईड्रोफ्लोरिक एसिड (40%आकुएऔस)
 आइसोप्रिन
 लेड कंपाउंड
 लिंडेन (गैमेक्सिन बीएचसी)
 मैलाथिओन
 मेरेयूरिक कंपाउंडस
 मिथाइल एल्कोहल
 मिथाइलिन क्लोराइड
 मोलासेस
 नैफथेलिन (मोल्टेम)
 नैपथेलिनथिओरिया
 निटसिस एसिड (90%)
 ओलियम
 पैराथियोन
 पैराक्वैट
 फिनोल
 फास्फोरिक एसिड
 फास्फोरस (प्राथमिक)
 पॉलिहैलोजीनेटिडबाईफिनाइल्स
 सोडियम पैंटाक्लोरोफिनेट (सोल्यूशन)
 स्टेरिनमोनोमर
 टौल्यून
 टौल्यून डाईआइसोसाइनेट
 टौक्साफिन
 ट्राईटोलिल फास्फेट (ट्राईक्रिसिल फास्फेट)
 2.4.5-टी

तरलीकृत गैस (जब थोक में लाई जा रही हो)

एसीटेलडीहाइड

एनहाइड्रस अमोनिया

ब्यूटाडीन

ब्यूटेन

ब्यूटेन / प्रोपेरी मिक्सर

ब्यूटेलीन

क्लोरीन

डाई मेथिलामीन

एथिल क्लोराइड

एथेन

एथीलीन

एथिलीन ऑक्साइड

मीथेन (एलएनजी)

मिथाइल एसिटीलिन प्रोपडलिन मिक्सचर

मेथिल ब्रोमाइड

मेथिल क्लोराइड

प्रोपेन

प्रोपीलीन

विनाइल क्लोराइड मोनोमर

निर्जल हाइड्रोजन क्लोराइड, निर्जल हाइड्रोजन फ्लोराइड या सल्फर डाईआक्साइड

अनुसूची-2**(नियम 4 देखें)****अंतर्देशीय पत्तन के लिए तेलीय मिश्रण उपचार उपस्कर विहित करना****तेलीय मिश्रण उपचार उपस्कर****1. प्राथमिक उपचार:**

सेटिलिंग टैंक्स: एक एपीआई सेपरेटर के लिए प्रवाह तेल एकाग्रता 50-200 पीपीएम होगा।

2. गौण उपचार:**(i) रसायन इमल्शन ब्रेकिंग / फ्लॉक्युलेशन एंड फ्लोटेशन:** 20-40 पीपीएम की जल चरण प्रवाह मात्रा इस तकनीक के साथ प्राप्त की जाएगी। इमल्शन ब्रेकिंग के लिए रसायनों की एक बड़ी विविधता उपलब्ध है। सबसे अधिक लोहा अथवा एल्यूमीनियम लवण और चर्गेड पॉलिमर इमल्शन ब्रेकिंग में प्रयुक्त होते हैं;**(ii) फिल्ट्रेशन:** जल चरण प्रवाह तेल एकाग्रता लगभग 20 पीपीएम होगा, जो 5 पीएम से कम भी हो सकता है, जब फ्लॉक्युलेशन के रसायन डाले जाए।**(iii) हाइड्रोसाईक्लोन्स:** हाइड्रोसाईक्लोन्स में तेल और जल के बीच घनत्व विभाजन प्रयुक्त होता है और विभाजन सेन्ट्रीफ्यूगल फ़ोर्स से प्राप्त किया जाता है। बेकार जल प्रवाल एकाग्रता हाइड्रोसाईक्लोन्स से पाया जाएगा जो लगभग 5-15 पीपीएम है।**(iv) सेन्ट्रीफ्यूगिस:** ये हाइड्रोसाईक्लोन्स के जैसे ही कार्य करता है। तथापि, ये स्थिर नहीं है, चूंकि इसका उपकरण घुमता है। इसका प्रयोग 3 चरण विभाजन (तेल, जल और ठोस) के लिए किया जा सकता है।**(v) मॉलिक्यूलर क्लेसेन्स तेल / जल विभाजक:** इसका मुख्य सिद्धान्त मॉलिक्यूलस जैसे का मॉलिक्यूलर जमावट है। इस जमावट की प्राप्ति एक तीव्र चरण के लिए ट्रैन्सिल चरण से ऊर्जा पैटर्न में बदलाव के द्वारा होती है। तेल के जल सामग्री 10% से कम है और अक्सर 1% से कम होता है।

3. तृतीयक उपचार:

जैविक उपचार: यहां पर बेकार जल नदियों में भंग जैविक घटकों कमी के लिए सूक्ष्म जीवों का उपयोग से पूरा किया है। तेल कचरे का फोर्ट उपचार, स्लज उपचार से प्राप्त स्टैण्डर्ड एरोबिक का प्रयोग किया जा सकता है। प्रवाह में तेल का डिस्चार्ज लेवल इस उपचार से 1 पीपीएम से कम गिर जाएगा।

4. तट पर तेल का मिश्रण उपचार उपकरणों के लिए विनिर्देश:

(i) उपचार इकाई से प्रवाह की तेल सामग्री जहां तक संभव हो कम रूप में होगी किंतु किसी भी मामले में 15 पीपीएम से अधिक नहीं होगा।

(ii) उपचार उपकरण मजबूत और निर्माण में मजबूत तथा उपयोग के लिए उपयुक्त होंगे।

(iii) कोई भी विद्युतीय उपकरण जो कि इस उपचार इकाई का भाग है को गैर खतरनाक क्षेत्र में अवस्थित किया जाएगा अथवा सक्षम प्राधिकारी द्वारा प्रमाणित किया जाएगा जो खतरनाक क्षेत्र में प्रयुक्त के लिए सुरक्षित हो।

(iv) उपचार इकाई को ऐसा बनाया जाएगा कि स्वयं ही कार्य करे, खराबी होने पर किसी भी डिस्चार्ज से बचने के लिए एक चूक सुरक्षा व्यवस्था प्रदान किया जाएगा।

(v) इस प्रणाली को प्रचालन में लाने के लिए कम से कम रखरखाव और ध्यान देने की जरूरत होगी। यह बिना ध्यान दिए सामान्य ड्यूटी के कम से कम चौबीस घंटे प्रचालन करने में कुशल होगा।

(vi) पीपीएम डिस्प्ले और अलार्म प्रदान किया जाएगा।

(vii) पीपीएम अलार्म की परिशुद्धता सक्षम व्यक्ति द्वारा निर्देशानुसार समय-समय पर विनिर्माता के दिशा-निर्देशों के अनुसार जांच की जाएगी। जांच प्रमाणपत्र की प्रति, जांच की तारीख का प्रमाण-पत्र देना निरीक्षण उद्देश्य के लिए पत्तन द्वारा अपने पास रखा जाएगा।

अनुसूची-3**(नियम 5 और 6 देखें)****अंतर्देशीय जलयान के लिए तेलीय मिश्रण उपचार उपस्कर विहित करना****भाग-I****तेल निस्यंदक उपस्कर (15 पीपीएम नितल, सैप्रेटरकारक) :-**

(1) 15 पीपीएम नितल सेपरेटर का मजबूती से निर्माण किया जाएगा और पोत पर अपनी इच्छित स्थान को ध्यान में रखते हुए जलयान के प्रयोग के लिए उपयुक्त होगा।

(2) यह, यदि उन स्थानों में लगाए जाने इरादा होगा जहां ज्वलनशील वातावरण मौजूद हो, ऐसे जगहों के लिए प्रासंगिक सुरक्षा विनियमों के साथ पालन किया जाएगा।

(3) 15 पीपीएम नितल सेपरेटर ऐसा बनाया जाएगा जो स्वयं कार्य करेगा। तथापि खराबी होने पर किसी भी डिस्चार्ज से बचने के लिए सुरक्षा व्यवस्था प्रदान किया जाएगा।

(4) इमल्सिफिएड नितल जल के लिए नितल से तेल नितल जल अथवा तेल और जल से वायु के 15 पीपीएम नितल सेपरेटर के लिए फिड में परिवर्तन किसी मिश्रण जिसमें तेल के 15 पीपीएम से अधिक हो ओवरबोर्ड डिस्चार्ज का परिणाम नहीं होगा।

(5) इस प्रणाली को प्रचालन में लाने के लिए कम ध्यान की जरूरत होगी। इंजन कक्ष नितल के मामले में, इस प्रणाली को प्रचालन में लाने के लिए किसी वोल्व और अन्य उपकरण को सुधारने की जरूरत नहीं होगी। यह उपकरण बिना ध्यान दिए सामान्य ड्यूटी के कम से कम चौबीस घंटे प्रचालन करने में कुशल होगा।

(6) 15 पीपीएम नितल सेपरेटर के सभी काम कर रहे भाग जो खराब हो सकते हैं उनकी सुगमता से मरम्मत की जाएगी।

15 पीपीएम नितल अलार्म:-

(1) 15 पीपीएम नितल अलार्म समुद्री पर्यावरण के हालात में जंग से संघर्ष करेगा।

(2) कोई विद्युतीय उपकरण जो 15 पीपीएम नितल अलार्मका भाग है को गैर खतरनाक क्षेत्र में अवस्थित किया जाएगा।

- (3) पीपीपी डिस्प्ले प्रदान किया जाएगा। विनिर्माता के दिशा-निर्देशानुसार ऑनबोर्ड जांच की जाएगी।
- (4) प्रतिक्रिया समय, यह वो समय है जो सैम्पल में एक परिवर्तन के बीच गुजरता है जो 15 पीपीएम नितल अलार्म को सप्लाय कर रहा है और पीपीएम डिस्प्ले पांच सेंकड से अधिक नहीं होगा।
- (5) 15 पीपीएम नितल अलार्म दिनांक, समय और अलार्म स्थिति और 15 पीपीएम नितल विभाजक का प्रचालन स्थिति दर्ज करेगा। दर्ज करने वाला उपकरण दर्ज डाटा को कम से कम अठारह महीनों तक रखा जाएगा।
- (6) 15 पीपीएम नितल अलार्म की परिशुद्धता को विनिर्माता के दिशा-निर्देशानुसार नवीकरण सर्वेक्षण में जांच किया जाएगा। 15 पीपीएम नितल अलार्म के लिए जांच प्रमाण-पत्र, अंतिम जांच की तारीख का प्रमाण-पत्र निरीक्षण उद्देश्य के लिए ऑन बोर्ड रखा जाएगा।

भाग - II

अंतर्देशीय जलयान के लिए धारक टैंक :-

नितल जल धारक टैंकों की क्षमता इस प्रकार होगी:

150 जीआरटी से कम जलयान अथवा 750 किलोवाट तक मुख्य इंजन रेटिंग1.0 एम3

जलयान (>150 जीआरटी और <400 जीआरटी) अथवा 1000 किलोवाट तक मुख्य इंजन रेटिंग 1.5 एम

जलयान (>400 जीआरटी और <3000 जीआरटी) अथवा मुख्य इंजन रेटिंग

(>1000 किलोवाट और < 20,000 किलोवाट) क्षमता: $1.5 + (पी-1,000)/1,500$, एम3

जलयान (>3000 जीआरटी) अथवा मुख्य इंजन रेटिंग (>20,000 किलोवाट)

क्षमता: $14:2+0.2 (पी-20,000)/1,500$ एम3

(पी=किलोवाट में मुख्य इंजन रेटिंग)

बशर्ते 150 जीआरटी से कम अंतर्देशीय के जलयान के लिए, जहां पर कम क्षेत्र के कारण, 1.0 एम3 धारक टैंक उपलब्ध करवाने के लिए व्यवहार्य नहीं है, सर्वेक्षक 750 किलोवाट इंजन रेटिंग के लिए 250 किलोवाट का अंतर्देशीय के जलयान के लिए 0.5 एम3 धारक टैंक और 250 किलोवाट इंजन रेटिंग से कम के लिए 0.25 एम3 उपलब्ध करवाने के लिए अनुमति देगा।

अनुसूची -4

(नियम 7 देखें)

तेल या तैलीय मिश्रण, गंदगी या अपशिष्ट और अभिहित प्रदूषकों के लिए प्राप्ति सुविधाओं के ब्यौरे

क. सामान्य उपबंध : (1) उपचार सुविधा अंतर्देशीय पत्तन पर स्थापित की जाएगी परन्तु संग्रहण उपकरण या तो चल हो सकते हैं अथवा किसी केन्द्रीय बिन्दु पर तट आधारित हो सकते हैं।

(2) तैलीय अपशिष्टों का संग्रहण या तो प्लवमान ग्रहण सुविधाओं जैसे पर्याप्त क्षमता वाले बार्जों द्वारा किया जा सकता है जिन्हें गैर प्रणोदित होने पर या तो खींच कर लाया जा सकता है अथवा वे स्व प्रणोदित हो सकते हैं अथवा स्थायी ग्रहण सुविधाओं के द्वारा किया जा सकता है जैसे अंतर्देशीय पत्तन में एक तट पर आधारित केन्द्रीय अपशिष्ट संग्रहण बिन्दु। राज्य सरकार अंतर्देशीय पत्तन के प्रचालन के आकार और उसकी प्रकृति के आधार पर सुविधा का प्रकार निश्चित कर सकती है।

ख.परिसंकटमय रसायनिकों या घृणाजनक पदार्थों के लिए पत्तन प्राप्ति सुविधाएं:-

संघटकों के ब्यौरे :

बफरिंग और इक्वालाइजिंग

बफरिंग/इक्वालाइजिंग टैंकों में, टैंकों को बफर्स के रूप में उपयोग करते हुए प्रक्रिया बहाव लगातार रहता है तथा जल प्रवाह की संरचना को तैलीय अपशिष्ट के कई बैचों के मिश्रण द्वारा इक्वालाइज किया जाता है।

प्लेट विभाजन

प्लेटविभाजकविभाजन के सतही क्षेत्र को बढ़ाने के सिद्धांत पर काम करते हैं जिसके परिणामस्वरूप बेहतर विभाजन प्राप्त होता है। किसी प्लेट विभाजक के साथ हासिल किया जा सकने वाला जल चरण प्रवाह लगभग 20-100 पीपीएम होता है।

फ्लोक्कुलेशन

इस तकनीक से 20-40 पी पी एम की जल चरण प्रवाह मात्रा हासिल की जाएगी। इमल्शन ब्रेकिंग के लिए कई किस्मों के रसायन उपलब्ध हैं। ज्यादातर इमल्शन ब्रेकिंग के लिए लैड अथवा एल्यूमीनियम साल्ट तथा आयनीकृत पोलिमर्स उपयोग में लाए जाते हैं।

फ्लोटेशन

यह एक यूनिट प्रचालन है जिसका उपयोग किसी तरल चरण से ठोस अथवा तरल कणों को अलग करने के लिए किया जाता है। एक अपशिष्ट जल टैंक में हवा के बुलबुले डाले जाते हैं तथा उठते हुए बुलबुले पपड़ीनुमा तेल कणों से जुड़ जाएँगे और उनकी उछाल को बढ़ाएँगे। एकीकृत कण तथा गैस के बुलबुले एक साथ सतह पर आ जाएँगे और तैरते कणों को एकत्रित किया जा सकता है।

जैविक उपचार

यहाँ अपशिष्ट जल प्रवाहों में घुले हुए जैविक घटकों की निम्नीकरण के लिए माइक्रो-जीवाश्मों का उपयोग किया जाता है। तैलीय अपशिष्ट के उपचार के लिए मानक वायुजीवी सक्रियकृत गाद उपचार का उपयोग किया जा सकता है। इस उपचार द्वारा प्रवाह में तेल के रिसाव स्तर को 1 पी पी एम से कम किया जाएगा।

ग. तेल या तैलीय मिश्रण या गंदगी या अपशिष्ट के लिए पत्तन प्राप्ति सुविधाएँ

अनुसूची 2 में यथाविनिर्दिष्ट

अनुसूची -5

(नियम 8 देखें)

अंतर्देशीय पत्तन ----- में (अवधि - से - तक) अभिहित प्रदूषकों की प्राप्ति के लिए अभिलेख बही

क्रम संख्या	जलयान का नाम	अभिहित प्रदूषकों/तेल/तैलीय मिश्रण या गंदगी या अपशिष्ट की प्राप्ति का समय और तारीख	अंतर्देशीय पत्तन का नाम	प्राप्त प्रदूषक का प्रकार	प्राप्त प्रदूषकों की मात्रा	प्राप्ति के लिए उदगृहीत फीस	निपटान की अंगीकृत पद्धति	टिप्पणियां
1.								
2.								
3.								
4.								
5.								
6.								
7.								
8.								
9.								
10.								

प्राधिकृत अधिकारी का नाम तथा हस्ताक्षर

प्राधिकारी की मुद्रा अथवा मुहर

अनुसूची 6

[नियम 9 (ii) देखें]

धारा 54 छ (1), (2) और (3) के अधीन नोटिस का प्रारूप

(राज्य सरकार का नाम) ----- की सरकार

(धारा 54 छ (1), (2) और (3) के अधीन नोटिस)

आपके ध्यान में यह लाया जाता है कि अंतर्देशीय पत्तन (पत्तन का नाम)..... का निरीक्षण अंतर्देशीय जलयान अधिनियम, 1917 की धारा 54 छ के उपबंध के अधीन(समय)(तारीख और वर्ष) को किया गया था। निरीक्षण में निम्नलिखित कमियाँ (कृपया प्रत्येक कमी के सामने अतिक्रमण किए गए सुसंगत आदेश या नियम का उल्लेख करें) पाई गईं।

कमियाँ	सुसंगत नियम अथवा आदेश
--------	-----------------------

- | | |
|---------|-------|
| 1. | |
| 2. | |
| 3. | |
| 4. | |

आपको एतद्वारा निम्नलिखित उपचारात्मक कार्रवाई करने की तथा अनुपालन की रिपोर्ट देने की सलाह दी जाती है

1.
2.
3.
4.

इस बात का नोटिस लें कि जब तक उपरोक्त सुधारात्मक कार्रवाई नहीं की जाती है तब तक आपके कार्गो / यात्री टर्मिनल पर सभी संक्रियाएं निलंबित रहेंगी।

जारी करने का स्थान :

जारी करने की तारीख :

(प्रमाणपत्र जारी करने वाले सर्वेक्षक का नाम और हस्ताक्षर)

(जारी करने वाले प्राधिकारी की सील अथवा मुहर, जो उचित हो)

अनुसूची 7

[नियम 9 (iii) देखें]

..... सरकार (राज्य सरकार का नाम)

संदर्भ संख्या :

अनुपालन /समरूपता प्रमाण पत्र (अनुसूची VI के संदर्भ में)

अंतर्देशीय पत्तन का नाम और पता :

यह प्रमाणित किया जाता है कि (पत्तन का नाम)..... को अनुसूची VI में कथित कमियों को सत्यापित करने के लिए अनुपालन निरीक्षण किया गया। पत्तन अब अंतर्देशीय जलयान अधिनियम, 1917 की धारा 54 जी में जैसे की कहा गया है के अनुसार अपेक्षाओं के साथ अनुपालन कर रहा है और इसलिए प्रचालन को दुबारा आरंभ करने के लिए अनुमति दी गई है।

अनुपालन की सत्यापन तारीख है।

जारी करने का स्थान

जारी करने की तारीख

(प्रमाण पत्र जारी करने वाले सर्वेक्षक का नाम और हस्ताक्षर)

(जारी करने वाले प्राधिकारी की सील अथवा मुहर, जो उचित हो)

अनुसूची 8

[नियम 9 (i) देखें]

..... सरकार (राज्य सरकार का नाम)

अनुपालन /समरूपता प्रमाण पत्र

(धारा 54 एफ और 54 एच के अंतर्गत जारी प्रमाण पत्र / क्रम संख्या)

अंतर्देशीय पत्तन का नाम और पता :

यह प्रमाणित किया जाता है कि (पत्तन का नाम)..... के उपकरण, सामग्री, रोकथाम, व्यवहार और अगवानी सुविधाओं की उपयुक्तता के संबंध में संबंधित प्रावधानों के अनुपालन के सत्यापन के लिए निरीक्षण किया गया। अंतर्देशीय पत्तन कथित प्रावधानों के अनुपालन को दर्शाता है और इसलिए अंतर्देशीय पत्तन को अब अनुपालन अथवा समरूपता प्रमाण पत्र जारी किया जाता है। जारी की गई तारीख से इस अनुपालन अथवा समरूपता की वैधता को समाप्त होती है, किंतु एक वर्ष की अवधि से अधिक नहीं वह भी निम्नलिखित शर्तों के अधीन :

1. अन्य प्रचालनों के परे अंतर्देशीय जल के निवारण एवं संरक्षण को हमेशा प्राथमिकता दी जाएगी।
2. पत्तन को प्रभावित करने वाली तेल प्रदूषण अथवा घटनाओं को जारी करने वाले प्राधिकारी को अधिसूचित की जाएगी।
3. पत्तन प्रचालन से प्रभावित प्रदूषण के संबंध से होता हुआ होने वाली किसी भी प्रकार की घटना जारी करने वाले प्राधिकारी को अधिसूचित किया जाएगा।
4. अंतर्देशीय जल के प्रदूषण के निवारण और संरक्षण को प्रभावित करने वाली तेलीय जल उपकरण के किसी भी खराबी अथवा दोष के अथवा में जारी करने वाले प्राधिकारी को अधिसूचित किया जाएगा।
5. अंतर्देशीय पत्तन में नए विकास से संबंधित किसी भी गतिविधि को जारी करने वाले प्राधिकारी को तुरंत रिपोर्ट किया जाना चाहिए ताकि किसी भी अतिरिक्त आवश्यकताओं के संबंध में समीक्षा आयोजित की जा सके।

अनुपालन की सत्यापन तारीख

जारी करने का स्थान

जारी करने की तारीख

(प्रमाण पत्र जारी करने वाले

सर्वेक्षक का नाम और हस्ताक्षर)

(जारी करने वाले प्राधिकारी की सील अथवा मुहर, जो उचित हो)

[फा. सं. एन. डब्ल्यू.-11015/1/2004-आई. डब्ल्यू. टी. (भाग-II)]

आलोक श्रीवास्तव, अतिरिक्त सचिव

MINISTRY OF SHIPPING**NOTIFICATION**

New Delhi, the 13th July, 2016

G.S.R. 687(E).—Whereas, the draft Inland Vessels (Prevention and Control of Pollution and Protection of Inland Water) Rules, 2016, were published, in exercise of the powers conferred by section 54H of the Inland Vessels Act, 1917 (1 of 1917) in the Gazette of India, Extraordinary, Part II, Section 3 sub-section (i) dated the 3rd February, 2016, vide GSR 144(E) dated 3rd February, 2016 as required by sub-section (1) of section 74 of the said Act inviting objections and suggestions from all persons likely to be affected thereby, before the expiry of the period of thirty days from the date on which copies of the Gazette containing the said draft rules were made available to the public.

The said notification was made available to the general public on the third day of February i.e., the 3rd February, 2016.

And, whereas, objection and suggestions received in respect of the said draft rules have been considered by the Central Government.

Now, therefore, in exercise of powers conferred by section 54H of the Inland Vessels Act, 1917, the Central Government makes the following Rules, namely:-

1. Short title and commencement. - (1) These rules may be called the Inland Vessels (Prevention and Control of Pollution and Protection of Inland Water) Rules, 2016.
(2) They shall come into force on date of their publication in the Official Gazette.
2. Definitions. - (1) In these rules, unless the context otherwise requires. -
 - (a) "Act" means the Inland Vessels Act, 1917;
 - (b) "any person" means any person authorised under section 54G of the Act which includes a surveyor or appointed under sub-section (1) of section 4 of the Act;
 - (c) "bilge water" means waste water collected in bilge of the vessel;
 - (d) "holding tank" means a tank used for the collection and storage of oily mixture or bilge water or sludge or pre wash of chemicals and obnoxious substances;
 - (e) "inland port" means a port located on Inland Waterway with the requisite facilities for safe berthing of vessels, loading and unloading arrangement of cargo, storage of cargo on land and provide water supply and fuel;
 - (f) "Schedule" means the Schedule annexed to these rules; and
 - (g) "sludge" means sludge from the fuel or lubricating oil separators, waste lubricating oil from main auxiliary machinery, or waste oil from bilge water separator, oil filtering equipment or drip trays.
- (2) Words and expressions used in rules and not defined but defined in the Act, shall have the meaning assigned to them in the Act.
3. The chemicals and substance specified in Schedule I shall be the hazardous chemicals and obnoxious substances for the purpose of a clause (a) section 54D.
4. Measures to prevent and control of pollution to protect inland water. -Every inland port shall provide oily mixture treatment equipment on shore as specified in Schedule II, within one year from the date of coming into force of these rules.
5. Every inland vessel above 1000 Gross Tonnes shall be equipped with oily mixture treatment equipment or board as specified in Part I of Schedule III, within one year from the date of coming into force of these rules.
6. Every inland vessel shall be equipped with a holding tank or equivalent arrangement of capacity as specified in Part II of Schedule III.
7. Every inland port shall provide reception facilities specified in Schedule IV, based on the nature of operation taking place on twenty four hours basis without delaying the vessel unreasonably, within one year from the date of coming into force of these rules.
8. An inland port at cargo or passenger terminal shall maintain Form and Record Books as specified in Schedule V.

9. At any time after one year from the coming into force of these rules, an inspection shall be carried out under section-54G of the Act by the surveyor or any person authorised by the State Government in this behalf and the following actions shall be taken,-

(i) if the Inland port is found to be provided with pollution containment equipment and removing material conforming to the orders of the State Government under section 54F of the Act or the rules made thereunder by the Central Government under Chapter VIAB, a certificate of compliance or conformity shall be issued in the Form prescribed in Schedule VIII;

(ii) if the surveyor finds that the Inland port is not provided with pollution containment equipment and removing material conforming to the orders of the State Government under section 54F of the Act or the rules made thereunder by the Central Government under Chapter VIAB, a notice in the Form as prescribed in Schedule VI pointing out deficiencies and directing the owner of the Inland port to take remedial action and report compliance within a period of thirty days from the date of receipt of notice; and

(iii) after compliance is reported and the surveyor is satisfied, a certificate of compliance or conformity shall be issued in the Form specified in Schedule VII.

SCHEDULE I

(see rule 3)

List of hazardous chemicals or obnoxious substances in bulk or in packaged form including wastes

Hazardous chemicals or Obnoxious Substances

Acetic anhydride
Acetone
Acetone Cyanohydrin
Acrolein
Acrylonitrile
Aldrin
Allylthiocyanate
Aluminium phosphide
Ammonia (28% aqueous)
Ammonium phosphate
Amyl mercaptan
Aniline
Aniline hydrochloride
Antimony compounds
Atrazine
Azinphos methyl (Guthion)
Barium azide,
Barium oxide
Benzene
Benzenehexachloride isomers (Lindane)
Benzidine
Beryllium Powder
Bromine
Bromobenzyl cyanide
n-Butyl acrylate
Butyric acid
Cacodylic compounds
Carbaryl (Sevin)

Carbon disulphide
Corbontetrachlride
Chloridane
Chloro~Cetophenone
Chlorodinitrobenzene
Chloroform
Chlorolhydrins(crude)
Chloropicrin
Chromic acid (Chromium trioxide)
Cococculus (Solid)
Copper compounds
Cresols
Cupriethylenediamine
Cyanide compound
Cyanogen bromide
Cyanogen chloride
DOT
Dichloroanilices
Dichlorobenzenes
Dieldrin
Dimethoate (Cygon)
Dimethyl amine (40%aqueous))
Dinitroanillnes
4.6-Dinitroorthocresol
Dinitrophenols
Endosulphan (Thiodan)
Endrin
Epichlorohydrin
Ethyl bromoacetate
Ethylene chlorohydrin (2-Chloro-ethanol)
Ethyl parathion
Fentin acetate (dry)
Fluosilicic acid
Heptachlor
Hexachlorobenzene
Hexaethyltetraphosohate
Hydrocyanic acid
Hydrofluoric acid n(40% aqueous)
Isoprene
Lead compounds
Lindane (Gammexane. BHC)

Malathion
Mercuric compounds
Methyl alcohol
Methylene chloride
Molasses
Naphthalene (molten)
Naphthylthiourea
Nitric acid (90%)
Oleum
Parathion
Paraquat,
Phenol
Phosphoric acid
Phosphorus (elemental)
Polyhalogenated biphenyls
Sodium pentachlorophenate (solution)
Styrene monomer
Toluene
Toluene diisocyanate
Toxaphene
Tritolyl phosphate (Tricresyl phosphate)
2, 4, 5- T
Liquefied Gases (when carried in bulk)
Acetaldehyde
Anhydrous Ammonia
Butadiene
Butane
Butane/Propene mixtures
Butylenes.
Chlorine
Dimethylamine
Ethyl chloride
Ethane
Ethylene
Ethylene Oxide
Methane (LNG)
Methyl Acetylene Propadiene mixture
Methyl Bromide
Methyl Chloride
Propane
Propylene
Vinyl Chloride Monomer
Anhydrous Hydrogen Chloride Anhydrous Hydrogen Fluoride or Sulphur Dioxide.

SCHEDULE II

(see rule 4)

Prescription for oily mixture treatment equipment for Inland Port

Oily Mixture treatment equipments.**1. Preliminary treatment:****Settling tanks:** The effluent oil concentration for an API separator shall be 50-200 ppm.**2. Secondary treatment:**(i) **Chemical emulsion breaking or flocculation and floatation:** The water phase effluent quantity of 20-40 ppm shall be achieved with this technique. A large variety of chemicals are available for emulsion breaking. Most frequently iron or aluminum salts and charged polymers are used for emulsion breaking;(ii) **Filtration:** The water phase effluent oil concentration shall be approximately 20 ppm, which can be lowered to 5 ppm, when flocculation chemicals are added.(iii) **Hydrocyclones:** Hydrocyclones use the density difference between oil and water for separation and separation is achieved by centrifugal force. The waste water effluent concentration shall be reached with hydrocyclones is approximately 5-15 ppm.(iv) **Centrifuges:** They work on the same principle as hydrocyclones. However, they are not static, as the equipment is rotated. They can be used for 3 phase separation (Oil, water and solids).(v) **Molecular Coalescence oil or water separator:** The main principle is the molecular coagulation of like molecules. The coagulation is achieved by changing the energy pattern from a tranquil phase to a rapid phase. The water content of the oil is less than 10% and frequently less than 1%.**3. Tertiary treatment:****Biological treatment:** Here the use of micro-organisms for degrading dissolved organic components in wastewater streams is done. For treatment of oily waste, standard aerobic activated sludge treatment can be used. The discharge level of oil in the effluent shall be reduced to less than 1 ppm by this treatment.**4. Specification for oily mixture treatment equipment on shore:**

(i) The oil content of the effluent from the treatment unit shall be as minimum as possible but in no case it exceed 15 ppm

(ii) The treatment equipment shall be strong and robust in construction and suitable for use.

(iii) Any electrical equipment that is part of the treatment unit shall be located in a non-hazardous area or certified by the competent authority as safe for use in hazardous areas.

(iv) The treatment unit shall be so designed that it functions automatically. A fail-safe arrangement to avoid any discharge in case of malfunction shall be provided.

(v) The system shall require minimum maintenance and attention to bring it into operation. It shall be capable of operating at least twenty four-hours of normal duty without attention.

(vi) A ppm display and alarm shall be provided

(vii) The accuracy of the ppm alarm shall be checked as per manufacturer's instruction periodically as directed by the competent person. A copy of calibration certificate, certifying the date of calibration shall be retained by the port for inspection purpose.

SCHEDULE III

(see rules 5 and 6)

Prescription for oily mixture treatment equipment for Inland vessel

Part -I**Oil filtering equipment (15 ppm bilge, separator):-**

(1) The 15 ppm bilge separator shall be strongly constructed and suitable for vessel's use bearing in mind its intended location on the vessel.

(2) It shall, if intended to be fitted in locations where flammable atmospheres may be present, comply with the relevant safety regulations, for such spaces.

(3) The 15 ppm bilge separator shall be so designed that it functions automatically. However, safe arrangements to avoid any discharge in case of malfunction shall be provided.

(4) Changing the feed to the 15 ppm bilge separator from bilge to oil bilge water to emulsified bilge water, or from oil and water to air shall not result in the discharge overboard of any mixture containing more than 15ppm of oil.

(5) The system shall require the minimum of attention to bring it into operation. In the case of engine room bilges, there shall be no need for any adjustment to valves and other equipment to bring the system into operation. The equipment shall be capable of operating for at least twenty-four hours of normal duty without attention.

(6) All working parts of the 15 ppm bilge separator which are likely to be damaged shall be easily accessible for maintenance.

15 ppm bilge alarm : -

(1) The 15 ppm bilge alarm shall resist corrosion in the conditions of the marine environment.

(2) Any electrical equipment which is part of the 15 ppm bilge alarm shall be placed in a non-hazardous area.

(3) A ppm display shall be provided. Onboard testing according to manufacturer's instructions shall be carried out.

(4) The response time, that is the time which elapses between an alteration in the sample being supplied to the 15 ppm bilge alarm and the ppm display shall not exceed five seconds.

(5) The 15 ppm bilge alarm shall record date, time and alarm status and operating status of the 15 ppm bilge separator. The recording device shall also store data for at least eighteen months.

(6) The accuracy of the 15 ppm bilge alarms shall be checked at renewal survey according to the manufacturer's instructions. The calibration certificate for the 15 ppm bilge alarm, certifying date of last calibration check, shall be retained on board for inspection purpose.

Part-II

Holding tank for Inland vessel:-

The capacity of bilge water holding tanks shall be as follows: -

Vessels below 150grt or main engine rating upto 750kw.... 1.0m³

Vessels (>150grt and <400grt) or main engine rating upto 1000Kw 1.5 m

Vessels (>400 grt and <3000 grt) or main engine rating

(>1000KW and <20,000kw) capacity: $1.5 + (P - 1,000) / 1,500$,m³

Vessels (>3000grt) or main engine rating (>20,000kw)

Capacity: $14:2 + 0.2 (P * - 20,000) / 1,500$ m³

*(P=main engine rating in kw)

Provided that for Inland Vessels of less than 150 grt, where due to space constraints, it is not practicable to provide 1.0m³ holding tank, the surveyor may allow for providing 0.5m³ holding tank for Inland Vessels of 250 kw to 750 kw engine rating and 0.25m³ for less than 250 KW engine rating.

SCHEDULE-IV

(see rule 7)

Details of reception facilities for oil or oily mixture, sludge or waste and designated pollutants.

A. **General provision:** (1) The treatment facility shall be established at Inland Port, but the collection equipment can either be mobile or shore based at a central point.

(2) Collection of oily wastes can be either by floating reception facilities like barges of adequate capacity either towed if non-propelled or self propelled or by fixed reception facilities such as one central shore based waste collection point in inland port. The State Government may prescribe the type of facility based on the size and nature of operation of the Inland port.

B. Port reception facilities for hazardous chemicals or obnoxious substances : -

Details of components:

Buffering and equalizing

In buffering/equalizing tanks, the process flow is continuous by using the tanks as buffers and the composition of the waste stream is equalised by mixing several batches of oily waste.

Plate Separation

Plate separators work on the principle of increasing the surface area of separation, resulting in a better separation. The water phase effluent reached with a plate separator is approximately 20-100ppm.

Flocculation

The water phase effluent quantity of 20-40 ppm shall be achieved with this technique. A large variety of chemicals are available for emulsion breaking. Most frequently iron or aluminum salts and charged polymers are used for emulsion breaking.

Flotation

This is a unit operation used to separate solid or liquid particles from a liquid phase. Air bubbles are injected into a waste water tank and the rising air bubbles will attach to the flocculated oil particles and increase their buoyancy. The combined particles and gas bubbles will rise to the surface and the floating particles can be collected.

Biological treatment

Here the use of micro-organisms for degrading dissolved organic components in wastewater streams is done. For treatment of oily waste, standard aerobic activated sludge treatment can be used. The discharge level of oil in the effluent shall be reduced to less than 1 ppm by this treatment.

C. Port reception facilities for oil or oily mixtures or sludge or waste

As specified is Schedule II.

Schedule V

(see rule 8)

Record book for receipt of designated pollutants in inland port.....(period from.....to.....)

S. No.	Name of the vessel	Time and date of receipt of designated pollutants/oil/oily mixture or sludge waste	Name of Inland port	Type of pollutant received	Quantity of pollutants received	Fee levied for the receipt	Method of disposal adopted	Remarks
1								
2								
3								
4								
5								
6								
7								
8								
9								
10								

Name and signature of authorised official

Seal or stamp of the authority

Schedule VI

{ see rule 9 (ii) }

Format for Notice under section 54G (1), (2) and (3)

Government of..... (Name of State Govt)

(NOTICE UNDER SECTION 54G (1), (2) and (3))

This is to bring to your notice that Inland port (name of the port).....was inspected under the provision of 54G of the Inland Vessels Act, 1917 on (date and year).....at (time)..... The inspection revealed the following deficiencies (please mention the relevant order or rules violated against each deficiency)

Deficiencies	Relevant rules or Order
1.
2.
3.
4.

You are hereby advised to take the following remedial action and report compliance

1.
2.
3.
4.

Take notice that till the time the above remedial action is taken, all operations at your Cargo/Passenger terminal will remain suspended.

Place of Issue:

Date of Issue:

(Name and Signature of the surveyor issuing the certificate)

(Seal or stamp of issuing authority, as appropriate)

Schedule-VII

{ see rule 9(iii) }

Government of (Name of State Govt.)

Reference number:

Certificate of Compliance/conformity (in context of Schedule VI)

Name and address of Inland Port:

This is to certify that the Inland port (name of the port) has been inspected to verify the compliance of deficiencies stated in Schedule VI. The port now is found to be complying with the requirements as stated in section 54G of the Inland Vessels Act, 1917 and therefore permitted to resume the operations.

The date of verification of compliance is

Place of Issue:

Date of Issue:

**(Name and Signature of the
Surveyor
Issuing theCertificate Surveyor)**

(Seal or stamp of Issuing authority, as appropriate)

Schedule VIII

{ see rule 9 (i) }

Government of (Name of State Govt.)**Certificate of Compliance/conformity****(Issued under section 54F and 54H)**

Certificate/Serial number---

Name and address of Inland Port:

This is to certify that the Inland port (name of the port) has been inspected to verify the compliance of the relevant provisions with respect to equipment, material, containment, treatment and adequacy of reception facilities. The Inland port demonstrates the compliance of stated provisions and therefore Certificate of compliance or conformity is now issued to the Inland port. The validity of this compliance or conformity expires on from the date of issue, but not later than a period of one year subject to the conditions stated below:

1. Prevention and preservation of inland water shall always be given priority over other operations.
2. Any incidents of oil pollution or chemical spillage affecting the port shall be notified to the issuing authority.
3. Any incident of casualty with respect to pollution affecting the port operations shall be notified to the issuing authority.
4. Any malfunction or defect of or in oily water equipment affecting prevention of pollution and preservation of inland water shall be notified to the issuing authority.
5. Any activity relating to new development in Inland port shall be immediately reported to the issuing authority for the purpose of conducting review in respect of any additional requirements.

The date of verification of compliance is

Place of Issue :

Date of Issue :

(Name of Signature of the
Survey or Issuing the Statement)

(Seal or stamp of Issuing authority, as appropriate)

[F. No. NW-11015/1/2004-IWT (Vol. II)]

ALOK SRIVASTAVA, Addl. Secy.