



भारतीय अन्तर्देशीय जलमार्ग प्राधिकरण
INLAND WATERWAYS AUTHORITY OF INDIA

(पत्तन पोत परिवहन और जलमार्ग मंत्रालय, भारत सरकार)

(Ministry of Ports, Shipping and Waterways)
(Govt. of India)



क्षेत्रीय कार्यालय:

गायघाट, पो0-गुलजारबाग

पटना- 800007

दूरभाष : 0612-2310026

फैक्स: 0612-2310029

Regional Office:

Gaighat, P. O. – Gulzarbagh,
Patna – 800007

Phone/Tele fax :0612-2310029

E-mail: iwaipn@rediffmail.com

File No-12-IWAI/ENGG/P (02)/2024-25 / 1712

Date: 27.01.2025

NOTICE INVITING QUOTATION (NIQ)

Sub: Extension of NIQ date for procurement/fabrication & fitting of elast coupling of CSD Yamuna at Athmalgola, Patna -reg.

Inland Waterways Authority of India (IWAI) invites sealed quotations from experienced resourceful and reputeded firm/contractors for procurement & fitting of elast coupling multi-mont sella type MMF100 for alternator coupling of auxiliary engine CAT make 3412 of CSD Yamuna at Athmalgola as per sample/ drawing (Drawing Enclosed).The detail of BOQ is enclosed as Annex-1.

The terms and conditions are as under: -

1. The firm shall be submitted the copy of PAN Card, GST Registration, Cancel cheque and firm registration certificate.
2. The work shall be completed within 07 (Seven days) from the date of receipt of work order.
3. In case of delay in completion of the above repairing work and delivery, liquidated damages will be applicable @ 1.0% per week subject to a maximum 10% on the total value of the contract.
4. Payments shall be released on submission of final bill along with receipt of challan within 15 days after deduction of statutory dues if any and duly certification by concern officials/officers.
5. The repairer shall have past exeperince related to similar nature of work/familiar with electrical/civil/mechanical work in revier side/riverine work etc.
6. The material shall be supplied as per sample/drawing (Drawing Enclosed).
7. The standard guarantee/warranty shall be applicable as per manufacturing norms/company rules and guarantee/warranty card/documents shall be submitted along with bill/invoice to this office.
8. The rates shall be written both in words and figures.
9. Price bid shall be submitted in the format attached at Annexure-I which should be duly signed and stamped by the supplier and without any deviation/condition.
10. Inland Waterways Authority of India (IWAI) reserves the right to accept or cancel any quotations without assigning any reason or any prior notices.

All the quotationer shall be addressed to the Director, IWAI, Gaighat, Patna 800007 in a sealed cover. Quotations will be received upto at 15:00 hrs on 29.01.2025 and will be opened on the same day at 15:30 hrs by the officers of the IWAI in the presence of the representative of quotationer who choose to attend.

5.02
27/1/2025

(V. Murugesan)

Director, IWAI, RO, Patna

Encl: - As stated above.

Copy to :

1. IWAI Notice board and Uploading IWAI Website



भारतीय अन्तर्देशीय जलमार्ग प्राधिकरण
INLAND WATERWAYS AUTHORITY OF INDIA

(पत्तन पोत परिवहन और जलमार्ग मंत्रालय, भारत सरकार)

(Ministry of Ports, Shipping and Waterways)
(Govt. of India)



क्षेत्रीय कार्यालय:
गायघाट, पो0-गुलजारबाग
पटना- 800007
दूरभाष : 0612-2310026
फैक्स: 0612-2310029

Regional Office:
Gaighat, P. O. – Gulzarbagh,
Patna – 800007
Phone/Tele fax :0612-2310029
E-mail: iwaiptn@rediffmail.com

File No-12-IWAI/ENGG/P (02)/2024-25 / 1665

Date: 21.01.2025

NOTICE INVITING QUOTATION (NIQ)

Sub: NIQ for procurement/fabrication & fitting of elast coupling of CSD Yamuna at Athmalgola-reg.

Inland Waterways Authority of India (IWAI) invites sealed quotations from experienced resourceful and reputed firm/contractors for procurement & fitting of elast coupling multi-mont sella type MMF100 for alternator coupling of auxiliary engine CAT make 3412 of CSD Yamuna at Athmalgola as per sample/ drawing (Drawing Enclosed).The detail of BOQ is enclosed as Annex-1.

The terms and conditions are as under: -

1. The firm shall be submitted the copy of PAN Card, GST Registration, Cancel cheque and firm registration certificate.
2. The work shall be completed within 07 (Seven days) from the date of receipt of work order.
3. In case of delay in completion of the above repairing work and delivery, liquidated damages will be applicable @ 1.0% per week subject to a maximum 10% on the total value of the contract.
4. Payments shall be released on submission of final bill along with receipt of challan within 15 days after deduction of statutory dues if any and duly certification by concern officials/officers.
5. The repairer shall have past experience related to similar nature of work/familiar with electrical/civil/mechanical work in river side/riverine work etc.
6. The material shall be supplied as per sample/drawing (Drawing Enclosed).
7. The standard guarantee/warranty shall be applicable as per manufacturing norms/company rules and guarantee/warranty card/documents shall be submitted along with bill/invoice to this office.
8. The rates shall be written both in words and figures.
9. Price bid shall be submitted in the format attached at Annexure-I which should be duly signed and stamped by the supplier and without any deviation/condition.
10. Inland Waterways Authority of India (IWAI) reserves the right to accept or cancel any quotations without assigning any reason or any prior notices.

All the quotationer shall be addressed to the Director,IWAI, Gaighat, Patna 800007 in a sealed cover. Quotations will be received upto at 15:00 hrs on 27.01.2025 and will be opened on the same day at 15:30 hrs by the officers of the IWAI in the presence of the representative of quotationer who choose to attend.

(V. Murugesan)
Director, IWAI, RO, Patna

Encl: - As stated above.

Copy to :

1. IWAI Notice board and Uploading IWAI Website

मुख्य कार्यालय :ए-13, सेक्टर-1, नोयडा,
जिला-गौतमबुद्ध नगर(उ० प्र०)
फोन : 0120-2544036/4000/4041/2521664

HEAD OFFICE: A-13,SECTOR-1,NOIDA,
GautamBudh Nagar (U.P.): 201301
E-mail : iwai@nic.in www.iwai.nic.in



BOQ for Procurement/Fabrication & fitting of elast coupling multimont sella type MMF100 for alternator coupling of auxiliary engine CAT make 3412 of CSD Yamuna at Athmalgola, Patna.

Sl. No.	Description of work	Unit	Qty.	Rate	Amount
1.00	Procurement/Fabrication & fitting of elast coupling multimont sella type MMF100 for alternator coupling of auxiliary engine CAT make 3412 of CSD Yamuna at Athmalgola, Patna as per sample/drawing (Drwaing enclosed) as per direction of EIC.				
1.10	Labour charges	No.	1.00		
1.20	Provision for Cost of spares (actual bill/invoice + 10%) basis	LS			

Note : Excluding GST as applicable

Handwritten signature
Patna

Handwritten signature
DD (M)

Seal with signature of
Quotationer

Handwritten signature
21/11/2025
Dir, Patna.

-W66

Elast. Coupling

Multimont Sella type MMS NF100

$$J_{tot} = 0,158 \text{ kg m}^2$$

$$\text{Weight} = 11,8 \text{ kg}$$

Generator

Ansaldo type MXM

Output 52 KVA

$$J = 0,521 \text{ kg m}^2$$

$$\text{Weight} : 300 \text{ kg}$$

pillar 3412 DI-T

7 KW 1500 r.p.m.

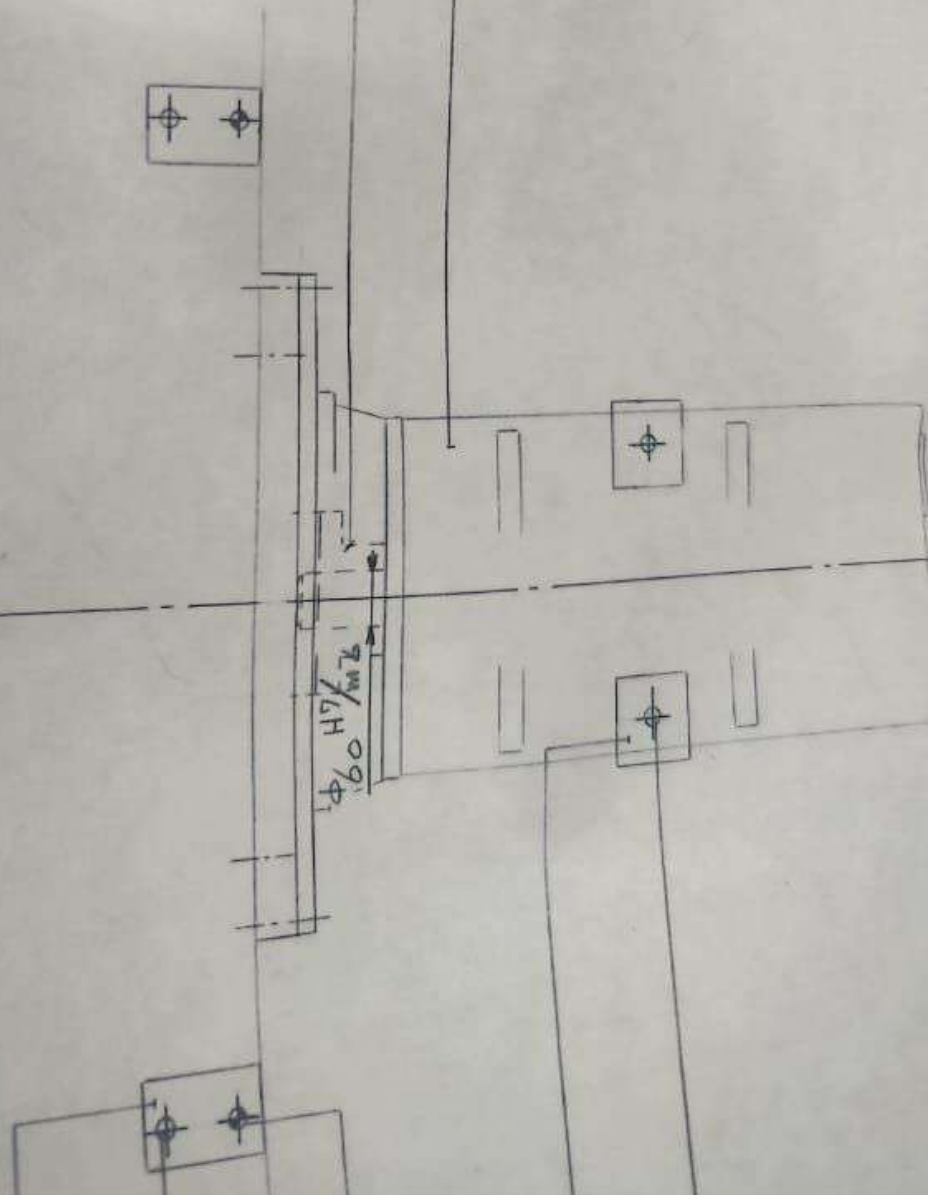

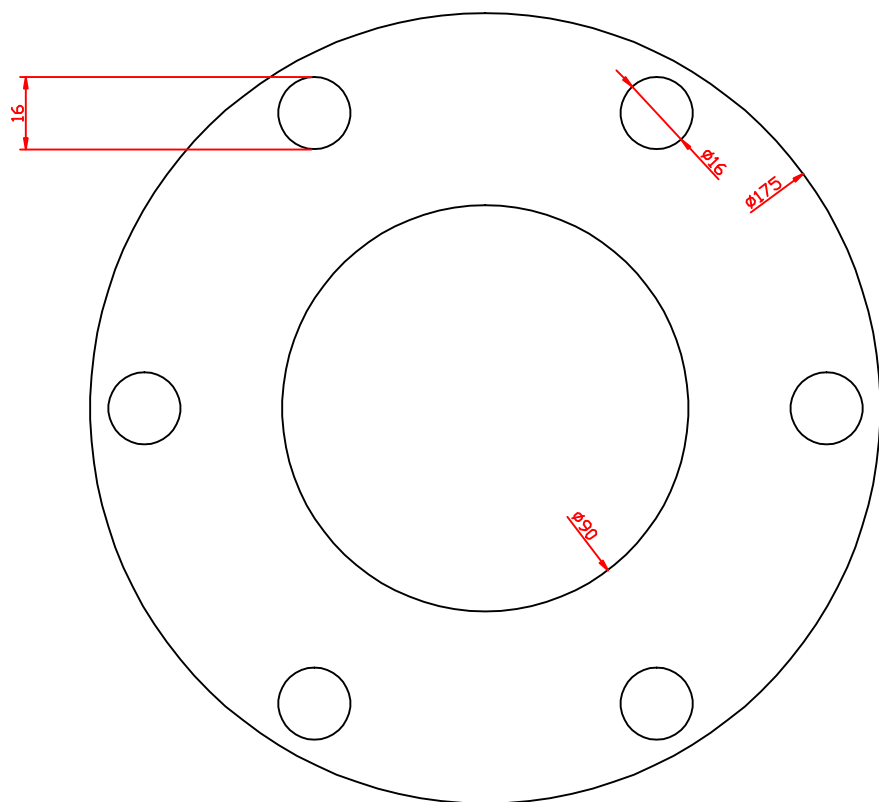

Female bottom view(Engine side)

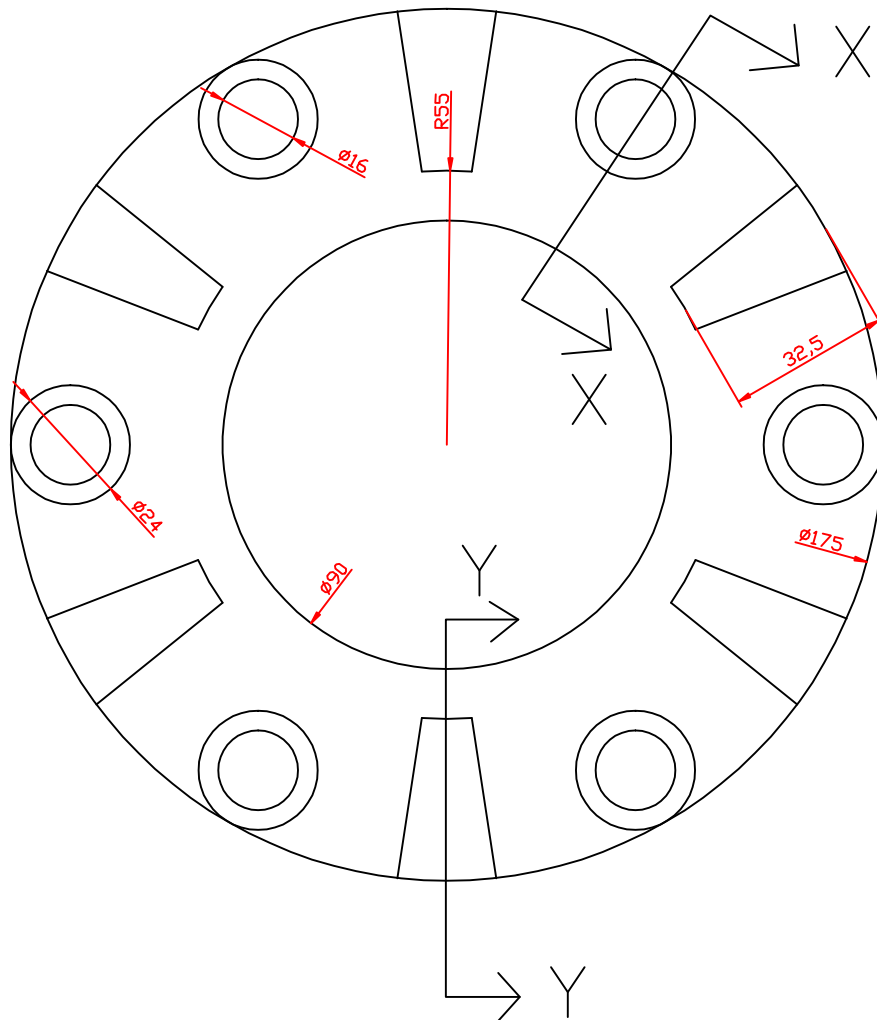

Female top view (Engine side)

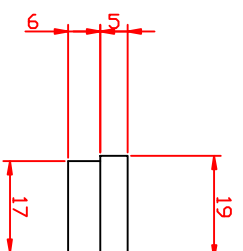

KEY top view

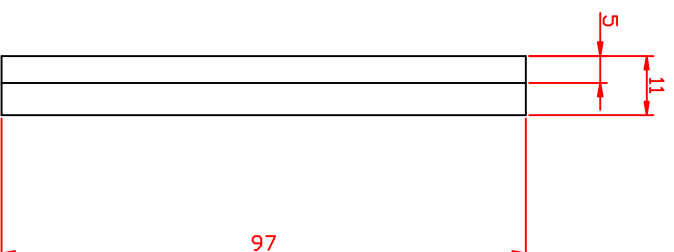

KEY Front view

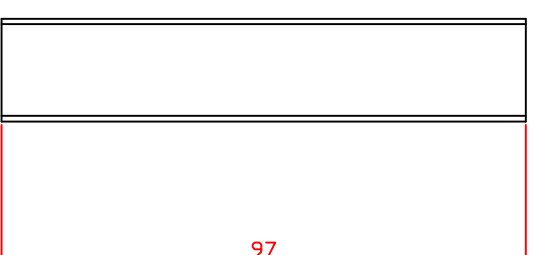

KEY Front view

KEY Tightning Hole

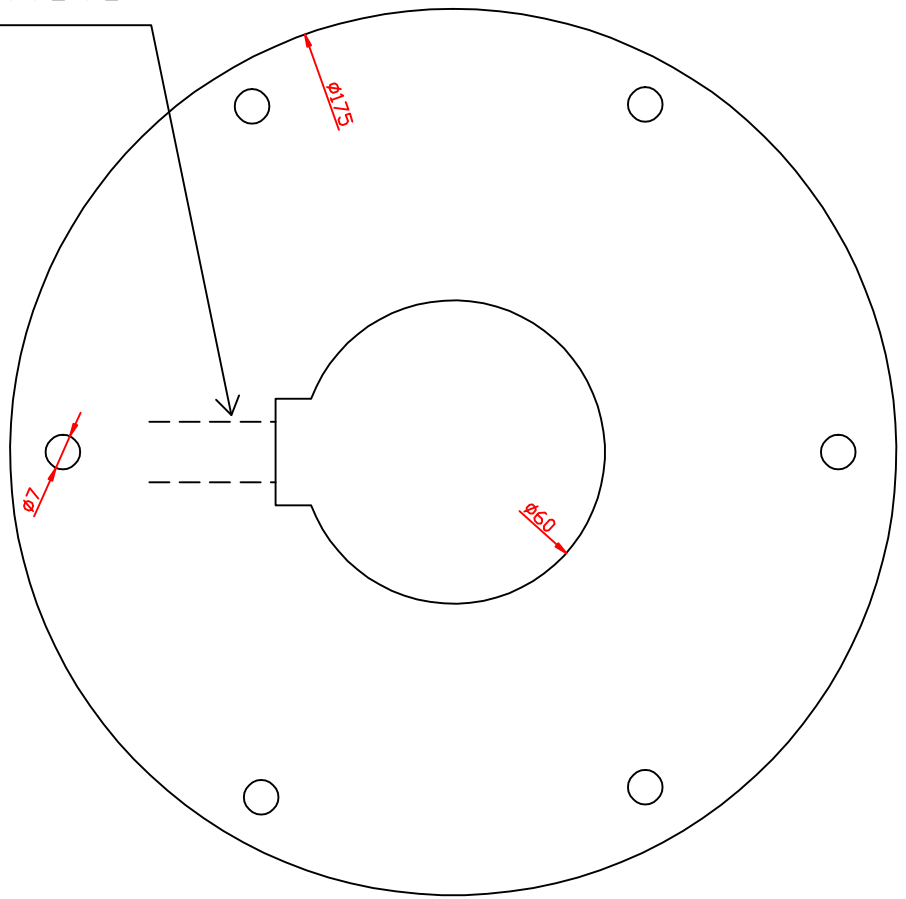

Male bottom view

KEY Tightning Hole

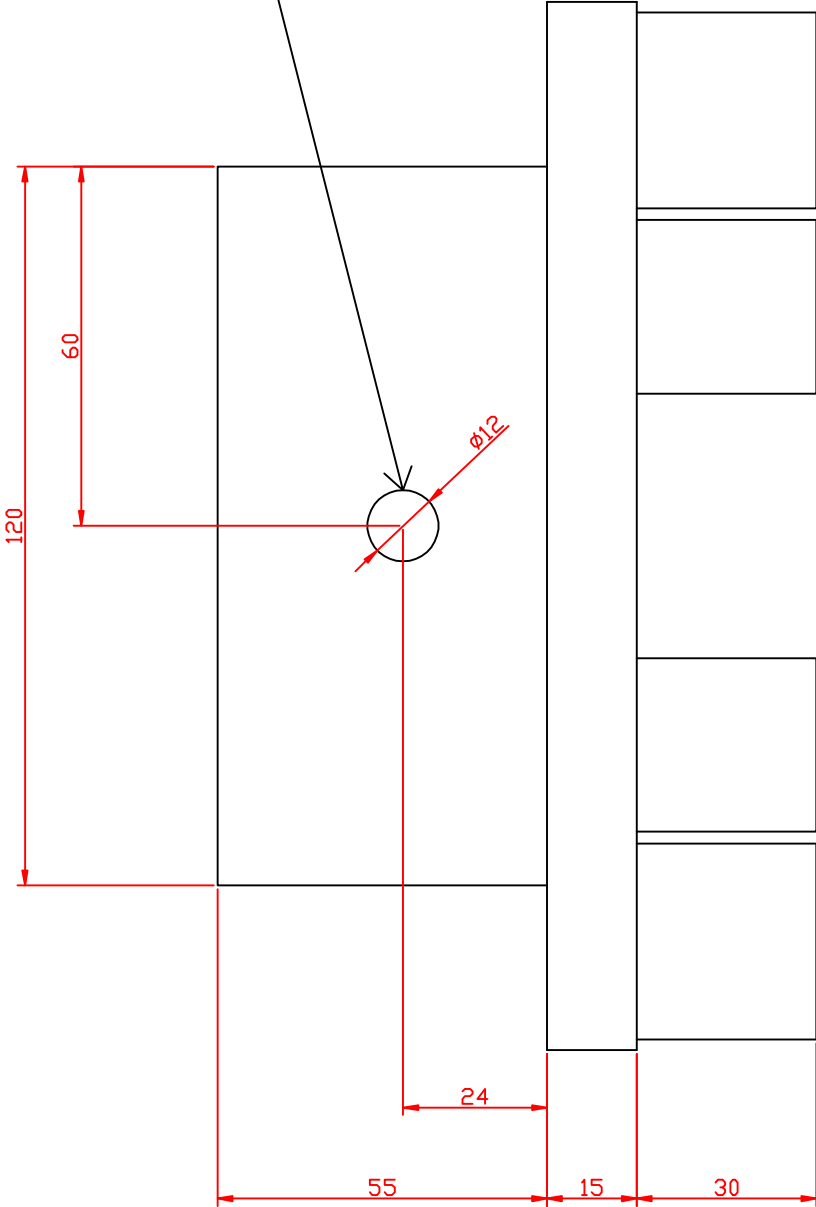

Male side view

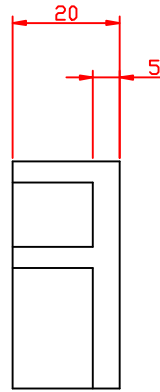

sectional view at
X-X (Engine side)

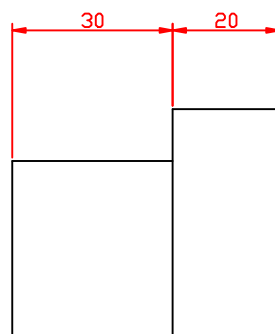

Sectional view at
Y-Y (Engine side)