



TENDER DOCUMENT

FOR

G.I barbed wire with RCC post (5line Horizontal)
fencing and Jungle clearance at land of extension
of Multi Modal Terminal, Ramnagar, Varanasi



Tender No: IWAI/PTN/17(18)/LA/Varanasi/Terminal/2020-21

INLAND WATERWAYS AUTHORITY OF INDIA

(Ministry of Ports, Shipping and Waterways, Govt. of India)
Head Office: A-13, Sector – 1, Noida-201 301 (U.P.)

Address of Issuing Office: IWAI, Gaighat, P.O-Gulzarbagh, Patna – 800007

E-mail address of Issuing Officer: dirpat.iwai@nic.in, iwaiptn@rediffmail.com

Web site:

www.iwai.gov.in<https://eprocure.gov.in/eprocure/app>

CHECK LIST

The technical bid shall be submitted online along with scanned copy of the following documents.

1. Scanned copy of Original Bid document duly completed in all respect except prices and signed with seal on every page.
2. Scanned copy of Blank Performa of Schedule of Prices (prices not to be filled)
3. Scanned copy of e-receipt of Earnest Money Deposit and tender cost (RTGS/NEFT as prescribed)
4. Scanned copy of GST and Firm Registration certificate from concerned Authorities.
5. Scanned copy of similar Experience certificate.
6. Scanned copy of Solvency certificate (Not earlier than 6 months).
7. Scanned copy of Letter of Authority for signing and negotiation of tender (as the case may be).
8. Scanned copy of Permanent Account Number (PAN) issued by Income Tax Department.
9. Scanned copy of Audited balance sheets with profit and loss account for the last 3 years. (F.Y.-2019-20, 2018-19 & 2017-18); Turnover certificate duly signed by CA with UDIN.
10. Scanned copy of Cancelled cheque for E-Payment (As per annexure-III)
11. Scanned copy of affidavit of Signed declaration stating that no alteration has been made in any form in the downloaded tender document to be attached.
12. Scanned copy of affidavit of the declaration that they have not been banned or black-listed by any Govt. or Quasi Govt. Agency or Public Sector Undertaking (PSU).
13. In addition to the above, the contractor is required to submit scanned copy of other document if any to full fill all the condition of the tender document and the same may be attached after thoroughly read/study failing which he will be treated as technically disqualified.



TENDER ACCEPTANCE LETTER
(To be given on Company Letter Head)

Date:

To,

Sub: Acceptance of Terms & Conditions of Tender.

Tender Reference No: IWA/PTN/17(18)/LA/Varanasi/Terminal/2020-21

Name of Tender / Work: -

Dear Sir,

1. I/ We have downloaded / obtained the tender document(s) for the above mentioned 'Tender/Work' from the web site(s) namely:

as per your advertisement, given in the above mentioned website(s).

2. I / We hereby certify that I / we have read the entire terms and conditions of the tender documents from Page No. _____ to _____ (including all documents like annexure(s), schedule(s), etc.), which form part of the contract agreement and I / we shall abide hereby by the terms / conditions / clauses contained therein.

3. The corrigendum(s) issued from time to time by your department/ organization too has also been taken into consideration, while submitting this acceptance letter.

4. I / We hereby unconditionally accept the tender conditions of above mentioned tender document(s) / corrigendum(s) in its totality / entirety.

5. In case any provisions of this tender are found violated , then your department/ organization shall without prejudice to any other right or remedy be at liberty to reject this tender/bid including the forfeiture of the full said earnest money deposit absolutely.

Yours Faithfully

(Signature of the Bidder, with Official Seal)



G.I barbed wire with RCC post (5line Horizontal)
fencing and Jungle clearance at land of
extension of Multi Modal Terminal, Ramnagar,
Varanasi

PART – A

TECHNICAL BID

NOTICE INVITING TENDER (NIT)



INLAND WATERWAYS AUTHORITY OF INDIA,
(Ministry of Ports, Shipping and Waterways, Govt. of India)
Gaighat, P.O.- Gulzarbagh, Patna- 800007 Telephone No. 0612-
2310026, 2310029

NOTICE INVITING TENDER

Tender no: IWAI/PTN/17(18)/LA/Varanasi/Terminal/2020-21

Inland Waterways Authority of India (IWAI) invites online bids/tenders from experienced, reputed and experienced contractors for Installation of G.I barbed wire with RCC post (5 line Horizontal) fencing and Jungle clearance at land of extension of Multi Modal Terminal, Ramnagar, Varanasi

Details and Tender document can be downloaded from 12.02.2021 to 20.02.2021 from our web site 'www.iwai.nic.in' and CPPP Portal '<https://eprocure.gov.in/eprocure/app>'. Last date for submission of online bids is 20.02.2021 up to 15:00 hrs. and date of opening of tender is on 22.02.2021 at 15:00 hrs. Submission of online bids will be through <https://eprocure.gov.in/eprocure/app>

-sd-

Director (I/C)



INLAND WATERWAYS AUTHORITY OF INDIA

(Ministry of Port, Shipping and Waterways, Govt. of India)

Head Office: A-13, Sector – 1, Noida - 201301, Distt.- Gautam Budh Nagar; (U.P.)

&

INLAND WATERWAYS AUTHORITY OF INDIA

(Ministry of Port, Shipping and Waterways, Govt. of India)

Gaighat, Gulzarbagh, Patna-800007

Telephone Nos. 0612-2310026, 2310029

NOTICE INVITING TENDER No.:

IWAI/PTN/17(18)/LA/Varanasi/Terminal/2020-21

Name of Work: - G.I barbed wire with RCC post (5 line Horizontal) fencing and Jungle clearance at land of extension of Multi Modal Terminal, Ramnagar, Varanasi

Inland Waterways Authority of India (IWAI) invites on line tenders in two cover system (Cover I - Technical bid and Cover II - Financial Bid) from reputed & experienced contractors for the work of G.I barbed wire with RCC post (5 line Horizontal) fencing and Jungle clearance at land of extension of Multi Modal Terminal, Ramnagar, Varanasi

1. The Bids will placed online at <https://eprocure.gov.in/eprocure/app>. Tender document may be downloaded from the <https://eprocure.gov.in/eprocure/app> as per the schedule as given in critical date sheet as under:-

Estimated Cost of the work, EMD requirement and Critical Dates are as under:-

| | |
|--|---|
| Name of Works | G.I barbed wire with RCC post (5line Horizontal) fencing and Jungle clearance at land of extension of Multi Modal Terminal, Ramnagar, Varanasi |
| Date of Publishing | 12.02.2021 |
| Document Download Start Date & Time | 12.02.2021 1200 Hrs. |
| Bid Submission start Date & Time | 12.02.2021 1300 Hrs. |
| Bid Closing/Document Download End Date & Time | 20.02.2021 1500 Hrs. |
| Bid Opening Date & Time | 22.02.2021 1500 Hrs. |
| Tender Fee | Rs. 2000+18% GST |

Estimated Cost of the work and EMD including GST requirement are as under:

| Sl. No. | Work | Estimated Cost (Rs.) | EMD (Rs.) | Solvency(Rs.) |
|---------|--|----------------------|-----------|---------------|
| 1. | G.I barbed wire with RCC post (5line Horizontal) fencing and Jungle clearance at land of extension of Multi Modal Terminal, Ramnagar, Varanasi | 7,86,196/- | 15,750/- | 3,20,000/- |

2. Bids shall be submitted online only at CPPP website <https://eprocure.gov.in/procure/app> Manual bids shall not be accepted and liable to be rejected.
3. The Hard Copy of original instruments in respect of cost of tender document, earnest money, other documents in original as asked in this **tender document must be delivered at the office of Director (I/C), IWAI, Gaighat, Patna-800007 on or before bid closing or opening date / time as mentioned in critical date sheet.** Bidder shall likely to be liable for legal action for non-submission of original payment instrument like RTGS/NEFT, against the submitted bid. Fee paid vide RTGS/NEFT for tender fee shall be non-refundable.

TERMS & CONDITIONS:-

4. **The tenderer shall meet the following pre-qualification criteria:**
 - i. The tenderer shall be registered with Central Public Works Department, Railways, MES and State PWD/ Irrigation Department or non-registered contractors having experience of working with IWAI.
 - ii. Tenderer shall have Permanent Account Number issued by Income Tax Deptt., GST number.
 - iii. Average annual financial turnover during last three years ending of the previous financial year, should be at least 30% of the cost. Experience of having successfully completed similar works during last seven years ending last day of month previous to the one in which this tender is invited should be either of following:
 - (a) Three similar works costing not less than 40% of the estimated cost; **or**
 - (b) Two similar works costing not less than 50% of the estimated cost; **or**
 - (c) One similar work completed not less than 80% of the estimated cost

- iv. Latest certificate of solvency from nationalized / scheduled Bank included in the second schedule of the RBI Act for not less than the value indicated below:

| Sl. No | Work | Bank solvency required (Rs.) |
|--------|--|------------------------------|
| 1. | G.I barbed wire with RCC post (5line Horizontal) fencing and Jungle clearance at land of extension of Multi Modal Terminal, Ramnagar, Varanasi | 3,20,000/- |

- v. The tenderer shall agree to the terms & conditions of the tender and return the tender duly signed in each page for agreeing the same.
- vi. The tenderer shall submit required Earnest Money Deposit in the form of RTGS/NEFT. Any/all submissions made without the earnest money and/or after the date mentioned hereinafter in clause 6 shall be deemed to be rejected.

Parties fulfilling the above indicative eligibility criteria can download tender document from the “<https://eprocure.gov.in/eprocure/app>” and IWAI’s website “www.iwai.nic.in”. Bidders submitting the downloaded version of tender document is required to submit 2000/- (Rupees Two Thousand only) +18% G.S.T i.e. an amount equal to the cost of tender document along with tender in the form of RTGS/NEFT made in favour of “IWAI fund SD and EMD” in the A/c No. 0352101046146, IFSC Code: CNRB0000352, Canara Bank, Main Branch, South Gandhi Maidan, Patna-800001. Payable at PATNA

An affidavit of declaration stating that no alteration has been made in any form in the downloaded tender document is to be enclosed with the tender by the bidder for downloaded tenders. Site can be inspected on all the working days during office hours. IWAI reserves the right to reject any or all the tender without assigning any reason thereof.

5. The firm may quote for work of indicated above and completed bids as per terms & Conditions mentioned in the tender document should be online submission at <https://eprocure.gov.in/eprocure/app> by 1500 hrs on 20.02.2021 and it will be opened on 22.02.2021 at 15:00 hrs.

6. For Special Attention

- All tenderers are cautioned that tenders containing any deviation whatsoever from the terms and conditions, specifications as contained in the tender documents are liable to be rejected as non-responsive.

The tender shall have to be submitted bid online in two bid format, the first part i.e. “Technical bid” should contain the scanned copy of entire tender document duly signed in all places, details of machineries, technical manpower, work schedule, and

earnest money deposit only but not the price bid. Second part i.e. ‘Financial bid’ shall contain only the rates of the item of work as in schedule. The price bid (BOQ of G.I barbed wire with RCC post (5line Horizontal) fencing and Jungle clearance at land of extension of Multi Modal Terminal, Ramnagar, Varanasi as per format provided along with this tender. Bid shall be submitted online separate covers super scribing as “technical bid” and “financial bid”.

7. Earnest Money Deposit (EMD) and tender cost must accompany each tender and tender not accompanied by the EMD & tender cost shall be rejected as NON-RESPONSIVE. The EMD & tender cost for an amount as specified above shall be submitted in the technical bid.

8. Opening Of Tenders & Evaluation

- (a) Tenders will be opened online by the tender evaluation committee at IWAI, Gaighat, Gulzarbagh, Patna-7 at **15:00 hrs on 22.02.2021** in the presence of representative of the tenders who choose to remain present.
- (b) After the online opening of the tenders, the first part i.e. Technical bid will be evaluated by the Tender Evaluation Committee (TEC) as constituted by the Authority. The second part i.e. Price bid will be opened online by the same T.E.C. only for those tenderers who become technically qualified after the evaluation of technical on a suitable date.

9. TENDER VALIDITY PERIOD

The tender shall remain valid for a period not less than 90 days after the date of opening of tenders.

Tenderer must read “Information & Instruction for Tenders” and be satisfied himself in respect to scope and the situation of works or any issue as related to the work as considered necessary before the submission of the tenders.

10. The authority shall have the right to reject any or all the tenders and will not be bound to accept the lowest or any other offer.
11. The complete bid (hard copy) as per the tender document should reach the office of Director (I/C), Inland Waterways Authority of India, Gaighat, P.O.-Gulzarbagh, Patna - 800007, on or before date & time of opening of tender. The technical bid will be **opened on 22.02.2021 at 1500 hrs** in the presence of intending bidders.
12. IWAI reserves the right to accept or reject any or all tenders without assigning any reason and no correspondence shall be entertained in this regard.

Director (I/C)



| INDEX | |
|----------------------------|--|
| S.No. | CONTENT |
| 1. | Tender acceptance letter |
| 2. | Notice Inviting Tender |
| 3. | Index |
| 4. | Instruction to the contractors / Bidders for the e-submission |
| <u>PART – I</u> | |
| 5. | Form of Tender |
| 6. | Instruction for submission of bid |
| 7. | PART-II - General Conditions of Contract |
| 8. | PART – III - Technical Specifications & Special Conditions |
| 9. | PART – IV - Schedule Bill of Quantities |
| <u>PART – V (ANNEXURE)</u> | |
| 10 | Annexure-I (Performa for agreement) |
| 11. | Annexure-II (Performa for Performance guarantee) |
| 12. | Annexure – III -E – PAYMENT FORMAT |
| 13. | Annexure – IV (Typical drawing & Map) |
| 14. | Public Procurement (Preference to make in India)-Revised Order |

Instructions to the Contractors / Bidders for the e-submission of the bids online through the Central Public Procurement Portal for eprocurement <https://eprocure.gov.in/eprocure/app>

- 1) Possession of valid Digital Signature Certificate (DSC) and enrollment/registration of the contractors/bidders on the e-procurement /e-tender portal is a prerequisite for e-tendering.
- 2) Bidder should do the enrollment in the e-procurement site using the <https://eprocure.gov.in/eprocure/app> option available on the home page. Portal enrollment is generally free of charge. During enrollment/registration, the bidders should provide the correct/true information including valid email_id. All the correspondence shall be made directly with the contractors/bidders through email_id provided.
- 3) Bidder need to login to the site thro' their user ID/ password chosen during enrollment/registration.
- 4) Then the Digital Signature Certificate (Class II or Class III Certificates with signing key usage) issued by SIFY/TCS/nCode/eMudra or any Certifying Authority recognized by CCA India on eToken/SmartCard, should be registered.
- 5) The DSC that is registered only should be used by the bidder and should ensure safety of the same.
- 6) Contractor/Bidder may go through the tenders published on the site and download the required tender documents/schedules for the tenders he/she is interested.
- 7) After downloading / getting the tender document/schedules, the Bidder should go through them carefully and then submit the documents as asked.
- 8) If there are any clarifications, this may be obtained online thro' the tender site, or thro' the contact details. Bidder should take into account of the corrigendum published before submitting the bids online.
- 9) Bidder then logs in to the site through the secured log in by giving the user id/ password chosen during enrolment/registration and then by giving the password of the eToken/SmartCard to access DSC.
- 10) Bidder selects the tender which he/she is interested in by using the search option & then moves it to the 'my favorites' folder.
- 11) From my favourites folder, he selects the tender to view all the details indicated.
- 12) It is construed that the bidder has read all the terms and conditions before submitting their offer. Bidder should go through the tender schedules carefully and upload the documents as asked; otherwise, the bid will be rejected.

- 13) Bidder, in advance, should get ready the bid documents to be submitted as indicated in the tender document/schedule and generally, they can be in PDF/xls/rar/jpg/dwf formats. If there is more than one document, they can be clubbed together and can be provided in the requested format. Each document to be uploaded through online for the tenders should be less than 2 MB. If any document is more than 2MB, it can be reduced through zip/rar and the same can be uploaded, if permitted.
- 14) If there are any clarifications, this may be obtained through the site, or during the pre-bid meeting if any. Bidder should take into account the corrigendum published from time to time before submitting the online bids.
- 15) The Bidders can update well in advance, the documents such as certificates, annual report details etc., under My Space option and these can be selected as per tender requirements and then send along with bid documents during bid submission. This will facilitate the bid submission process faster by reducing upload time of bids.
- 16) Bidder should submit the Tender Fee/ EMD as specified in the tender. The original payment instruments should be posted/couriered/given in person to the Tender Inviting Authority within the due date as mentioned in this tender document. Scanned copy of the instrument should be uploaded as part of the offer, if asked for.
- 17) While submitting the bids online, the bidder reads the terms & conditions and accepts the same to proceed further to submit the bid packets.
- 18) The bidder has to select the payment option as offline to pay the TFEE/ EMD as applicable and enter details of the instruments.
- 19) The details of the NEFT/RTGS/any other accepted instrument, physically sent, should tally with the details available in the scanned copy and the data entered during bid submission time. Otherwise submitted bid will not be acceptable.
- 20) The bidder has to digitally sign and upload the required bid documents one by one as indicated. Bidders to note that the very act of using DSC for downloading the bids and uploading their offers shall be deemed to be a confirmation that they have read all sections and pages of the bid document including General conditions of contract without any exception and have understood the entire document and are clear about the requirements of the tender requirements.
- 21) The bidder has to upload the relevant files required as indicated in the cover content. In case of any irrelevant files, the bid will be rejected.
- 22) If the price bid format is provided in a spread sheet file like BoQ_xxxx.xls, the rates offered should be entered in the allotted space only and uploaded after filling the relevant columns. The Price Bid/BOQ template must not be modified/replaced by the bidder, else the bid submitted is liable to be rejected for this tender.
- 23) The bidders are requested to submit the bids through online e-tendering system to the Tender Inviting Authority (TIA) well before the bid submission end date & time (as per

Server System Clock). The TIA will not be held responsible for any sort of delay or the difficulties faced during the submission of bids online by the bidders at the eleventh hour.

- 24) After the bid submission, the acknowledgement number, given by the e-tendering system should be printed by the bidder and kept as a record of evidence for online submission of bid for the particular tender and will also act as an entry pass to participate in the bid opening date.
- 25) The bidder should ensure/see that the bid documents submitted should be free from virus and if the documents could not be opened, due to virus, during tender opening, the bid is likely / liable to be rejected.
- 26) The time settings fixed in the server side & displayed at the top of the tender site, will be valid for all actions of requesting, bid submission, bid opening etc., in the e-tender system. The bidders should follow this time during bid submission.
- 27) All the data being entered by the bidders would be encrypted using PKI encryption techniques to ensure the secrecy of the data. The data entered will not be viewable by unauthorized persons during bid submission & not be viewable by any one until the time of bid opening.
- 28) Any bid document that is uploaded to the server is subjected to symmetric encryption using a system generated symmetric key. Further this key is subjected to asymmetric encryption using buyers/bid openers public keys. Overall, the uploaded tender documents become readable only after the tender opening by the authorized bid openers.
- 29) The confidentiality of the bids is maintained since the secured Socket Layer 128 bit encryption technology is used. Data storage encryption of sensitive fields is done.
- 30) The bidder should logout of the tendering system using the normal logout option available at the top right hand corner and not by selecting the (X) exit option in the browser.
- 31) For any queries regarding e-tendering process , the bidders are requested to contact through the modes given below:
E-mail: iwaiptn@rediffmail.com
Contact Telephone Numbers: _0612-2310026, Fax No. : 0612-2310029
Person: Sh. Arvind Kumar, Director (I/C)

FORM OF TENDER

To,
The Director (I/C),
Inland Waterways Authority of India,
IWT Terminal,
Gaighat P.O.- Gulzarbagh
Patna - 800007 (Bihar)

Name of Work: **G.I barbed wire with RCC post (5line Horizontal) fencing and Jungle clearance at land of extension of Multi Modal Terminal, Ramnagar, Varanasi**

Sir,

1. Having visited the site and examined the information and instructions for submission of tender, General conditions of contract, Special Condition of contracts, Technical, General and Detailed specification, Schedules and Bill of Quantities, agreement and bank guarantee forms, etc for the above named works, I/ We hereby tender for execution of the works referred to in the tender documents in conformity with the said Conditions of Contract, Specifications, Schedule of quantities for the sum as stated in Bill of quantities of this tender Document or such other sum as may be ascertained in accordance with the said conditions of contract.
2. I/ We undertake to complete and Deliver the whole of the works comprised in the Contract within the time as stated in the tender and also in accordance in all respects with the specifications, designs, drawings and instructions as mentioned in the tender documents.
3. I am tendering for the works mentioned in the table below and submitting the EMD separately for each work of National waterway vide RTGS/NEFT in favor of IWAI SD & EMD payable at Patna at Nationalized / Schedule Bank as per the details given therein:

| SL. No | Name of Work | RTGS/NEFT UTR NO. | EMD (RS.) | Details of Bank (Name of Bank, Branch address) |
|--------|---|-------------------|-----------|--|
| 1. | G.I barbed wire with RCC post (5line Horizontal) fencing and Jungle clearance at land of extension of Multi Modal Terminal, Ramnagar, Varanasi | | | |

4. I/ We agree to abide by this tender. I/ We agree to keep the tender open for a period of 90 days from the date of opening of price bids or extension thereto as required by the IWAI and not to make any modifications in its terms and conditions.

5. I/ We agree, if I/ we fail to keep the validity of the tender open as aforesaid or I/ we make any modifications in the terms and conditions of my/ our tender if I/ We fail to commence the execution of the works as above, I/ We shall become liable for forfeiture of my/ our Earnest money, as aforesaid and IWAI shall without any prejudice to another right or remedy, be at the liberty to forfeit the said Earnest Money absolutely otherwise the said earnest money shall be retained by IWAI towards part of security deposit to execute all the works referred to in the tender documents upon the terms and conditions contained or referred to therein and to carry out such deviations as may be ordered. Should this tender be accepted, I/ We agree to abide by and fulfill all the terms and conditions and provisions of this tender. No interest is payable on earnest money deposit and/ or security deposit.
6. I/ We have independently considered the amount of Liquidated Damages shown in the tender hereto and agree that it represents a fair estimate of the loss likely to be suffered by IWAI in the event of works not being completed in time.
7. If this tender is accepted, I/ We undertake to enter into execute at my/ our cost when called upon by the employer to do so, a contract agreement in the prescribed form. Unless and until a formal Agreement is prepared and executed this tender together with your written acceptance thereto shall constitute a binding contract.
8. If my/ our tender is accepted, I/We am/are to be jointly and severely responsible for the due performance of the Contract. I/We also declare that the firm has not been banned or blacklisted by any Govt. or its department or any Quasi Govt. agency or Public Sector Undertaking.
9. I/ We understand that you are not bound to accept the lowest or any tender you may receive and may reject all or any tender without assigning any reason.
10. I/ We certify that the tender submitted by me, us is strictly in accordance with the terms, conditions, specifications etc. as contained in the tender document, and it is further certified that it does not contain any deviation to the aforesaid documents.

Date

Signature

Name

Designation

duly authorized to sign & submit tender for an on behalf

of (Name and address of
firm)

M/s

.....

Telephone nos.....FAX No.....

Witness :

Signature.....

Name :

.....

Occupation

Address

Telephone nos.

WARRANTY FORM

M/s _____

_____ having its registered office at _____ (hereinafter referred to as the contractor) having carefully studied all the documents, specifications, designs, drawings etc pertaining to the contract for works required for the work of _____ and the local and site conditions and having under taken to execute the said works:

DO HEREBY WARRANT THAT:

1. The contractor is familiar with all the requirements of the contract.
2. The Contractor has investigated the site and satisfied himself regarding the character of the work and local conditions that may affect the work or its performance.
3. The contractor is satisfied that the work can be performed and completed as required in the contract.
4. The contractor accepts all risks directly or indirectly, connected with the performance of the contract.
5. The contractor has no collusion with other contractors, with any of the men of the Engineer-in-Charge or with any other person in Authority to execute the said works according to the terms and conditions of the said contract.
6. The contractor has not been influenced by any statement or promise of the Authority or Engineer-in-Charge but only by the contract documents.
7. The Contractor is financially solvent.
8. The Contractor is experienced and competent to perform the contract to satisfaction of the Engineer-in-Charge.
9. The Statement submitted by the contractor is true.
10. The contractor is familiar with all general and special laws, Acts, Ordinance, Rules & Regulation of the Municipalities, District, State and Central Government that may affect the work, its performance or personnel employed therein or environment.

Date:

For and on behalf of the Contractor.

Signature : _____

Name : _____

Stamp : _____

INLAND WATERWAYS AUTHORITY OF INDIA

(Ministry of Port, Shipping and Waterways, Govt. of India)

INSTRUCTIONS FOR SUBMISSION OF BID

1.0 All covering letters and information to be included in the bid shall be submitted along with the bid itself.

2.0 This tender schedule is only for the work of “G.I barbed wire with RCC post (5line Horizontal) fencing and Jungle clearance at land of extension of Multi Modal Terminal, Ramnagar, Varanasi”

2.1 Work wise total estimated cost of works is as under:

| Sl.No. | Name of work | Estimated Cost including all taxes, levies, cess etc. In rupees |
|--------|---|---|
| 1 | G.I barbed wire with RCC post (5line Horizontal) fencing and Jungle clearance at land of extension of Multi Modal Terminal, Ramnagar, Varanasi | 7,86,196/- |

4.0 Tender should be submitted **on line** in two cover system

Cover – 1 (Part-I) : Technical & Commercial Bid.

Cover – 2 (Part-II) : Price Bid of offer.

Cover –1 :

The first cover shall be submitted along with the following documents and the cover should be super scribed with “TECHNICAL/ COMMERCIAL BID FOR G.I barbed wire with RCC post (5line Horizontal) fencing and Jungle clearance at land of extension of Multi Modal Terminal, Ramnagar, Varanasi

- a) Scanned copy of Original Bid document duly completed in all respect except prices and signed with seal on every pages,
- b) Scanned copy of Blank Performa of Schedule of Prices (prices not to be filled)
- c) Scanned copy of e-receipt of Earnest Money Deposit and tender cost (RTGS/NEFT as prescribed)
- d) Scanned copy of GST and Firm Registration certificate from concerned Authorities.
- e) Scanned copy of similar Experience certificate.
- f) Scanned copy of Solvency certificate (Not earlier than 6 months).
- g) Scanned copy of Letter of Authority for signing and negotiation of tender (as the case may be).
- h) Scanned copy of Permanent Account Number (PAN) issued by Income Tax Department.
- i) Scanned copy of Audited balance sheets with profit and loss account for the last 3 years. (F.Y.-2019-20, 2018-19 & 2017-18); Turnover certificate duly signed by CA with UDIN
- i) Scanned copy of Cancelled cheque for E-Payment (As per annexure-III)
- j) Scanned copy of affidavit of Signed declaration stating that no alteration has been made in any form in the downloaded tender document to be attached.
- k) Scanned copy of affidavit of declaration that they have not been banned or black-listed by any Govt. or Quasi Govt. Agency or Public Sector Undertaking (PSU).
- l) In addition to the above, the contractor is required to submit scanned copy of other document if any to full fill all the condition of the tender document and the same may be attached after thoroughly read/study failing which he will be treated as technically disqualified.

Note:- The Tenderer shall also submit the hard copies of tender in two sealed covers (apart from online copy) marked “Cover-1st” and “Cover-2nd”. The cover 1st shall contain the Tender Fee, EMD and technical bids. The cover 2nd shall contain the Price bids. In case the first cover is not submitted with EMD & Tender Fee in a proper form, the second cover shall not be opened and rejected summarily. Both cover-1 & cover-2 are to be placed in a single cover. Duly sealed covers containing the hard copies of technical and financial bids will be put in a separate single cover which should be sealed. The full name, postal address and phone/ Fax of the Bidder shall be written on the bottom left hand corner of each of the sealed envelopes.

Cover - 2:

The second cover shall be submitted along with the following documents and the cover should be super scribed with “and the cover should be super scribed with “ENVELOPE-2: PRICE BID FOR G.I barbed wire with RCC post (5line Horizontal) fencing and Jungle clearance at land of extension of Multi Modal Terminal, Ramnagar, Varanasi”

Schedule of Prices duly filled in the specified form, i.e. “SCHEDULE etc.”
(Whichever is relevant).

- (i) It may please be noted that this part shall not contain any terms & conditions. Any condition given in the price bid (envelope-2) will be a sufficient cause for rejection of bid.
 - (ii) The bidder must ensure to quote the rate of each item of Bill of Quantities. If the bidder has omit / left some items, then the rate of such items shall be treated as zero value.
- 5.0 Bidders are advised to submit on line quotation strictly based upon technical specification, terms and conditions contained in technical specifications, terms and conditions contained in documents and not to stipulate any deviations. Any change in this may lead to rejection of bid.
- 6.0 Earnest Money Deposit separately for each stretch as indicated against stretch of NW-1 in the Notice inviting tender should be submitted by RTGS/NEFT drawn in favor of **“IWAI fund SD and EMD” in the A/c No. 0352101046146, IFSC Code: CNRB0000352, Canara Bank, Main Branch, South Gandhi Maidan, Patna-800001. Payable at PATNA** on any Nationalized / Scheduled Bank of India for each stretch. Bids not accompanied with EMD/tender cost in form of RTGS/NEFT are liable for rejection. However Micro, Small and Medium Enterprises (MSME)/NSIC or are registered with the Central Purchase Organization Ministry or Department or Startups as recognized by Department of Industrial Policy & Promotion (DIPP) are exempted from depositing EMD and Tender Fee.
- 7.0 In case the bidder decide not to participate for this work, then the down loaded complete set of bid document may kindly be withdrawn from the e-tender CPPP site.
- 8.0 The bids can only be submitted in the name of the bidder in whose name the bid documents were downloaded.
- 9.0 Any annotations or accompanying documentation in the bid shall be in Hindi or English language only and in metric system. Tenders filled in any other language will be summarily rejected.
- 10.0 Bidders shall sign their proposal with the exact name of the firm to whom the bid document has been issued. The bid shall be duly signed and sealed by an authorized person of the bidder’s organization as following:
- 10 (a) If the Tender is submitted by an individual, it shall be signed by the proprietor above his full name and full name of his firm with its current business address.

- 10 (b) If the Tender is submitted by the proprietary firm, it shall be signed by the proprietor above his full name and full name of his firm with its name and current business address
- 10 (c) If the Tender is submitted by a firm in partnership, it shall be signed by all the partners of the firm above, their full names and current business address, or by a partner holding the power of attorney for the firm for signing the Tender in which cases a certified copy of the power of attorney shall accompany the Tender. A certified copy of the partnership deed and current business address of all the partners of the firm shall also accompany the Tender.
- 10 (d) If the Tender is submitted by a limited company, or a limited Corporation, it shall be signed by a duly authorized person holding the power of attorney for signing the tender in which case a certified copy of the power of attorney shall accompany the Tender. Such limited company or corporation may be required to furnish satisfactory evidence of its existence before the contract is awarded. 'Satisfactory evidence' means the certificate of incorporation of the limited company or corporation under Indian Companies Act, 1956.
- 10 (e) If the Tender is submitted by a group of firms, the sponsoring firm shall be submit complete information pertaining to each firm in the group and state along with the bid as to which of the firm shall have the responsibility for tendering and for completion of the contract document and furnish evidence admissible in law in respect of the authority assigned to such firm on behalf of the group of firms for tendering and for completion of the contract document. The full information and satisfactory evidence pertaining to the participation of each member of the group of firm in the firm in the Tender shall be furnished along with the Tender.
- 10 (f) All witnesses and sureties shall be persons of status and their full names, occupations and addresses shall be stated below their signatures. All signatures affixed in each pate in the tender will be dated.
- 11.0 Bidders shall clearly indicate their legal constitution and the person signing the tender shall state his capacity and also the source of his ability to bind the bidder. The power of attorney or authorization or any other document constituting adequate proof of the ability of the signatory to bind the bidder shall be annexed to the bid. The Owner may reject outright any bid unsupported by adequate proof of the signatory's authority.
- 12.0 **The bid document shall be completed in all respects and shall be submitted on line together with the requisite information and appendices. The Tenderer shall also submit the hard copies of Tender in two sealed covers (apart from on line copy) marked "Cover-1" and "Cover - 2".** They shall be complete and free from ambiguity, change or inter-lineation. In case IWAI requires any information/ clarification(s) from the Bidder in respect of the bid documents, the bidder shall be required to furnish the same in writing, to IWAI at the earliest where no time is specified by IWAI to furnish the same. A failure to furnish the same shall entitle IWAI to cancel/ reject the bid
- 13.0 If the space in the bid form or in the Appendices thereto is insufficient, additional pages shall be separately added. These pages shall be consecutively page numbered and shall also be signed by the Bidder.
- 14.0 The Bid documents shall be signed by the bidder on each page.
- 15.0 Bidders should indicate at the time of quoting against this bid their full postal addresses, telephone numbers and other communication details enabling IWAI to contact the bidder in case the need so arise.

- 16.0 Bidder shall set their quotations in firm figures and without qualification. Each figure stated should also be repeated in words and in the event of any discrepancy between the amounts stated in figures and words; the amount quoted in words shall be deemed the correct amount. Bid containing qualifying expressions such as “subject to minimum acceptance” or “subject to availability of material/ equipment” etc. is liable to be rejected.
- 17.0 IWAI shall have a unqualified option under the said bid bond to claim the amount there under in the event of the Bidder failing to keep the bid valid up to the date specified or refusing to accept work or carry it out in accordance with the bid if the IWAI decides to award the Work to the Bidder.
- 18.0 The EMD shall be retained with the IWAI until finalization of tenders. Further, security deposit as per the clause of Security shall be payable by the successful bidder. If the tenderer fails to furnish the security deposit in accordance with tender conditions EMD shall be forfeited. In the event of the Bidder becoming the successful Contractor. The amount of EMD would be adjusted against the Security deposit.
- 19.0 IWAI shall, however, arrange to release the EMD in respect of unsuccessful bidders within 30 days of placement of order to successful bidder. No interest shall be payable on EMD by IWAI.
- 20.0 Late bids, delayed bids received after the stipulated last date and time for receipt of bids, due to any reasons whatsoever will not be considered.
- 21.0 The Tender Evaluation Committee (TEC) shall open the tenders in the presence of the intending tenderers who may be present at the date and time of opening informed in the bid document or subsequently. If any of the tenderer or his agent is not present at the time of opening of tender, the TEC shall, on opening of tenders of the absentee tenderer, prepare a statement of the attested and unattested corrections in the tender over their signature. Such a list shall then be binding on the absentee tenderer.
- 22.0 The successful tenderers shall be required to execute a contract agreement in the given format. In case of any refusal/ failure on the part of such successful tenderer to execute such a contract shall be deemed to be a failure on the part of such successful bidder to comply with the terms contained herein.
23. **Suspension of Business of Contractor**

As per clause No 22.2 & 22.3 of CPWD Enlistment rule -2005 modified up to 08.07.2013 suspension of business and removed from the list and are not eligible for award of any work whenever adverse report related to adverse performance, misbehavior, direct and indirect involvement in threatening, making false complaint, filing legal suites for playful reasons, hampering tender process or execution of contract or any act, omission or commission etc. damaging the reputation of department / Officer or other type of complaint considered fit by Authority,.

24. Banned or Blacklisted Contractors

The bidder shall give an Affidavit of declaration that they have not been banned or black-listed by any Govt. or Quasi Govt. Agency or Public Sector Undertaking (PSU). If a bidder has been banned by any Govt. or Quasi Govt. Agency or PSU, this fact must be clearly stated and it may not necessarily be a cause of disqualifying the firm. If this declaration is not given, the bid shall be rejected as non-responsive.

25. LAST DATE AND TIME FOR SUBMISSION AND OPENING

The tender shall be received on line up to **15.00 hrs. on 20.02.2021** and shall be opened at **15.00 hrs. on 22.02.2021** in the presence of authorized representatives of the tenderers who would like to be present at the time of opening. The hard copy of tender should reach on or before date & time of opening of tender. Late receipt of required document shall not be considered.

26. EARNEST MONEY DEPOSIT

The tender shall be accompanied by RTGS/NEFT in favour of **“IWAI fund SD and EMD” in the A/c No. 0352101046146, IFSC Code: CNRB0000352, Canara Bank, Main Branch, South Gandhi Maidan, Patna-800001. Payable at PATNA.** However Micro, Small and Medium Enterprises (MSME)/NSIC or are registered with the Central Purchase Organization Ministry or Department or Startups as recognized by Department of Industrial Policy & Promotion (DIPP) are exempted from depositing EMD and Tender Fee.

27. VALIDITY OF PRICES

The tenderer should quote the rate for various items of work in prescribed schedule. The rates quoted should be firm and should be kept valid for consideration for at least 90 days from the date of opening of price bids or extension thereto as required by the IWAI and not to make any modifications in its terms and conditions.

28. DETAILS OF OFFER

- i) IWAI reserves the right to segregate the work to one or more parties without assigning any reason thereof.
- iii) IWAI has the right to reject any or all of the tenders without assigning any reasons and will not be bound to accept the lowest or any other tender or to give any reason for such decision.

PART – II

**To be signed by the bidders’ and same signatory competent/ authorized
to sign the relevant contract on behalf of IWAI.**

INTEGRITY AGREEMENT

This Integrity Agreement is made at.....on thisday of20

BETWEEN

Chairperson, Inland Waterways Authority of India represented through Director (I/C), Inland Waterways Authority of India, Gaighat, Gulzarbagh, Patna-800007.

IWAI, (Hereinafter referred as the ‘Principal/ Owner’, which expression shall unless repugnant to the meaning or context hereof include its successors and permitted assigns)

AND

.....(Name and Address of the Individual/firm/Company) through..... (Hereinafter referred to as the (Details of duly authorized signatory) “Bidder/Contractor” and which expression shall unless repugnant to the meaning or context hereof include its successors and permitted assigns)

Preamble

1. WHEREAS the Principal / Owner has floated the Tender (NIT No: IWAI/PTN/17(6)/RCW&NNL/R-M/2019-20) (hereinafter referred to as “Tender/Bid”) and intends to award, under laid down organizational procedure, contract for “G.I barbed wire with RCC post (5line Horizontal) fencing and Jungle clearance at land of extension of Multi Modal Terminal, Ramnagar, Varanasi
2. . Herein after referred to as the “Contract”.

AND WHEREAS the Principal/Owner values full compliance with all relevant laws of the land, rules, regulations, economic use of resources and of fairness/transparency in its relation with its Bidder(s) and Contractor(s).

AND WHEREAS to meet the purpose aforesaid both the parties have agreed to enter into this Integrity Agreement (hereinafter referred to as “Integrity Pact” or “Pact”), the terms and conditions of which shall also be read as integral part and parcel of the Tender/Bid documents and Contract between the parties.

NOW, THEREFORE, in consideration of mutual covenants contained in this Pact, the parties hereby agree as follows and this Pact witnesses as under:

Article 1: Commitment of the Principal/Owner

- 1) The Principal/Owner commits itself to take all measures necessary to prevent corruption and to observe the following principles:

- (a) No employee of the Principal/Owner, personally or through any of his/her family members, will in connection with the Tender, or the execution of the Contract, demand, take a promise for or accept, for self or third person, any material or immaterial benefit which the person is not legally entitled to.
 - (b) The Principal/Owner will, during the Tender process, treat all Bidder(s) with equity and reason. The Principal/Owner will, in particular, before and during the Tender process, provide to all Bidder(s) the same information and will not provide to any Bidder(s) confidential/additional information through which the Bidder(s) could obtain an advantage in relation to the Tender process or the Contract execution.
 - (c) The Principal/Owner shall Endeavour to exclude from the Tender process any person, whose conduct in the past has been of biased nature.
- 2) If the Principal/Owner obtains information on the conduct of any of its employees which is a criminal offence under the Indian Penal code (IPC)/Prevention of Corruption Act, 1988 (PC Act) or is in violation of the principles herein mentioned or if there be a substantive suspicion in this regard, the Principal/Owner will inform the Chief Vigilance Officer and in addition can also initiate disciplinary actions as per its internal laid down policies and procedures.

Article 2: Commitment of the Bidder(s)/Contractor (s)

1. It is required that each Bidder/Contractor (including their respective officers, employees and agents) adhere to the highest ethical standards, and report to the IWAI all suspected acts of fraud or corruption or Coercion or Collusion of which it has knowledge or becomes aware, during the tendering process and throughout the negotiation or award of a contract.
2. The Bidder (s)/Contractor (s) commit himself to take all measures necessary to prevent corruption. He commits himself to observe the following principles during his participation in the Tender process and during the Contract execution:
 - a) The Bidder(s)/Contractor(s) will not, directly or through any other person or firm, offer, promise or give to any of the Principal/Owner's employees involved in the tender process or execution of the contract or to any third person any material or other benefit which he/she is not legally entitled to, in order to obtain in exchange any advantage of any kind whatsoever during the Tender process or during the execution of the contract.
 - b) The Bidder(s)/Contractor(s) will not enter with other Bidder(s) into any undisclosed agreement or understanding, whether formal or informal. This applies in particular to prices, specifications, certifications, subsidiary contracts, submission or non-submission of bids or any other actions to restrict competitiveness or to cartelize in the bidding process.
 - c) The Bidder (s)/Contractor (s) will not commit any offence under the relevant IPC/PC Act. Further the Bidder (s)/Contract (s) will not use improperly, (for the purpose of competition or personal gain), or pass on to others, any information or documents provided by the Principal/Owner as part of the business relationship,

Regarding plans, technical proposals and business details, including information contained or transmitted electronically.

- d) The Bidder (s)/Contractor (s) of foreign origin shall disclose the names and addresses of agents/representatives in India, if any. Similarly Bidder (s)/Contractor (s) Of Indian Nationality shall disclose names and addresses of foreign agents/representatives, if any. Either the Indian agent on behalf of the foreign principal or the foreign principal directly could bid in a tender but not both. Further, in cases where an agent participate in a tender on behalf of one manufacturer, he shall not be allowed to quote on behalf of another manufacturer along with the first manufacturer in a subsequent/parallel tender for the same item.
 - e) The Bidder (s)/Contractor (s) will, when presenting his bid, disclose any and all payments he has made, is committed to or intends to make to agents, brokers or any other intermediaries in connection with the award of the Contract.
3. The Bidder (s)/Contractor (s) will not instigate third persons to commit offences outlined above or be an accessory to such offences.
 4. The Bidder (s)/Contractor (s) will not, directly or through any other person or firm indulge in fraudulent practice means a willful misrepresentation or omission of facts or submission of fake/forged documents in order to induce public official to act in reliance thereof, with the purpose of obtaining unjust advantage by or causing damage to justified interest of others and/or to influence the procurement process to the detriment of the Government interests.
 5. The Bidder (s)/Contractor (s) will not, directly or through any other person or firm use Coercive Practices (means the act of obtaining something, compelling an action or influencing a decision through intimidation, threat or the use of force directly or indirectly, where potential or actual injury may befall upon a person, his/ her reputation or property to influence their participation in the tendering process).

Article 3: Consequences of Breach

Without prejudice to any rights that may be available to the Principal/Owner under law or the Contract or its established policies and laid down procedures, the Principal/Owner shall have the following rights in case of breach of this Integrity Pact by the Bidder (s)/Contractor(s) and the bidder/contractor accepts and undertakes to respect and uphold the Principal/Owner's absolute right:

1. If the Bidder (s)/Contractor (s), either before award or during execution of Contract has committed a transgression through a violation of Article 2 above or in any other form, such as to put his reliability or credibility in question, the Principal/Owner after giving 14 days" notice to the contractor shall have powers to disqualify the Bidder (s)/Contractor (s) from the tender process or terminate/determine the Contract, if already executed or exclude the Bidder/Contractor from future contract award processes. The imposition and duration of the exclusion will be determined by the severity of transgression and determined by the Principal/Owner. Such exclusion may be forever or for a limited period as decided by the Principal/Owner.
2. Forfeiture of EMD/Performance Guarantee/Security Deposit: If the Principal/Owner has disqualified the Bidder (s) from the tender process prior to the award of the contract

or terminated/determined the contract or has accrued the right to terminate/determine the contract according to Article 3 (1), the Principal/Owner apart from exercising any legal rights that may have accrued to the Principal/Owner, may in its considered opinion forfeit the entire amount of Earnest Money Deposit, Performance Guarantee and Security Deposit of the Bidder/Contractor.

3. Criminal Liability: If the Principal/Owner obtains knowledge of conduct of a bidder or Contractor, or of an employee or a representative or an associate of a bidder or Contractor which constitutes corruption within the meaning of IPC Act, or if the Principal/Owner has substantive suspicion in this regard, the Principal/Owner will inform the same to law enforcing agencies for further investigation

Article 4: Previous Transgression

- 1) The Bidder declares that no previous transgressions occurred in the last 5 years with any other Company in any country confirming to the anticorruption approach or with Central Government or State Government or any other Central/State Public Sector Enterprises in India that could justify his exclusion from the Tender process.
- 2) If the Bidder makes incorrect statement on this subject, he can be disqualified from the Tender process or action can be taken for banning of business dealings/ holiday listing of the Bidder/Contractor as deemed fit by the Principal/ Owner.
- 3) If the Bidder/Contractor can prove that he has resorted / recouped the damage caused by him and has installed a suitable corruption prevention system, the Principal/Owner may, at its own discretion, revoke the exclusion prematurely.

Article 5: Equal Treatment of all Bidders/Contractors/Subcontractors

- 1) The Bidder (s)/Contractor (s) undertake (s) to demand from all subcontractors a commitment in conformity with this Integrity Pact. The Bidder/Contractor shall be responsible for any violation (s) of the principles laid down in this agreement/Pact by any of its Subcontractors/ sub-vendors.
- 2) The Principal/Owner will enter into Pacts on identical terms as this one with all Bidders and Contractors.
- 3) The Principal/Owner will disqualify Bidders, who do not submit, the duly signed Pact between the Principal/Owner and the bidder, along with the Tender or violate its provisions at any stage of the Tender process, from the Tender process.

Article 6: Duration of the Pact

This Pact begins when both the parties have legally signed it. It expires for the Contractor/Vendor 12 months after the completion of work under the contract or till the continuation of defect liability period, whichever is more and for all other bidders, till the Contract has been awarded. If any claim is made/lodged during the time, the same shall be binding and continue to be valid despite the lapse of this Pacts as specified above, unless it is discharged/determined by the Competent Authority, IWAI.

Article 7: Other Provisions

- 1) This Pact is subject to Indian Law, place of performance and jurisdiction is the Headquarters of the Division of the Principal/Owner, who has floated the Tender.
- 2) Changes and supplements need to be made in writing. Side agreements have not been made.
- 3) If the Contractor is a partnership or a consortium, this Pact must be signed by all the partners or by one or more partner holding power of attorney signed by all partners and consortium members. In case of a Company, the Pact must be signed by a representative duly authorized by board resolution.
- 4) Should one or several provisions of this Pact turn out to be invalid; the remainder of this Pact remains valid. In this case, the parties will strive to come to an agreement to their original intentions.
- 5) It is agreed term and condition that any dispute or difference arising between the parties with regard to the terms of this Integrity Agreement / Pact, any action taken by the Owner/Principal in accordance with this Integrity Agreement/ Pact or interpretation thereof shall not be subject to arbitration.

Article 8: LEGAL AND PRIOR RIGHTS

All rights and remedies of the parties hereto shall be in addition to all the other legal rights and remedies belonging to such parties under the Contract and/or law and the same shall be deemed to be cumulative and not alternative to such legal rights and remedies aforesaid. For the sake of brevity, both the Parties agree that this Integrity Pact will have precedence over the Tender/Contact documents with regard any of the provisions covered under this Integrity Pact.

IN WITNESS WHEREOF the parties have signed and executed this Integrity Pact at the place and date first above mentioned in the presence of following witnesses:

.....
(For and on behalf of Principal/Owner)

.....
(For and on behalf of Bidder/Contractor)

WITNESSES:

1.
(signature, name and address)

2.
(signature, name and address)

Place:

Date:

SCHEDULES

SCHEDULE 'A' : Salient Features of the work.

Name of Work : G.I barbed wire with RCC post (5line Horizontal) fencing and Jungle clearance at land of extension of Multi Modal Terminal, Ramnagar, Varanasi

Estimated cost of work: The estimated cost of the work is given below on schedule basis including all taxes including GST as applicable.

| Work | Estimated Cost (Incl. GST) | EMD (Rs.) |
|--|-------------------------------|-------------|
| G.I barbed wire with RCC post (5line Horizontal) fencing and Jungle clearance at land of extension of Multi Modal Terminal, Ramnagar, Varanasi | Rs 7,86,196/- | Rs 15,750/- |

(a) Performance Guarantee : 5% of awarded value.

(b) Security Deposit : 5% of awarded value.

SCHEDULE 'B' : General Rules & Directions with reference to General Conditions of Contract: -

- (i) Officer inviting tender: -Director (I/C), IWAI, Gaighat, Patna-800007
- (ii). **Tender Accepting Authority:**-Director (I/C), IWAI, Gaighat, Gulzarbagh, Patna-800007
- (iii). (a) **Time allowed for submission of Performance Guarantee as per clause 3.1 of GCC from the date of issue of letter of acceptance:-** 15 days
- (b) **Maximum allowable extension beyond the period provided in (iii) (a) above:-** 7 days
- (iv) **Percentage on Cost of Materials & Labour to cover all overheads and profits:-** 15%
- (v) **Standard Schedule of Rates:-** Reference of DSR/ Market Rates
- (vi) **Specification to be followed :-** As per Tender Document
- (vii) **Deviation Limit beyond which clause 16.3, 16.4, 16.5 & 16.6: -** 20%
- (viii) **Competent authority of grant extension of time under clause 34:-**
 - (a) Member (Technical), IWAI (if the amount of contract is upto 200 lakhs).
 - (b) Vice-Chairman/ Chairperson, IWAI, Noida (if the cost of contract is Upto 1000 lakhs)
 - (c) Chairman, IWAI, Noida (Full Powers).

(ix) Competent authority to levy liquidated damages for delay under clause 35:-

- (d) Member (Technical), IWAI (if the amount of contract is upto 100 lakhs).
- (e) Vice-Chairman/ Chairperson, IWAI, Noida (if the cost of contract is more than 100 lakhs & up to 500 lakhs).
- (f) Chairman, IWAI, Noida (if the amount of contract is more than 500 lakhs).

(x) Competent authority to determine the contract as per clause 36:-

- (g) Engineer-in-Charge with the prior approval of
- (h) Member Technical), IWAI (if the amount of contract is upto 100 lakhs).
- (i) Vice-Chairman/ Chairperson, IWAI, Noida (if the cost of contract is more than 100 lakhs & up to 500 lakhs).
- (j) Chairman, IWAI, Noida (if the amount of contract is more than 500 lakhs).

(xi) Milestones as per table given below:

(Clause 34.5 & 34.6 shall be applicable only when the amount of the contract is more than 10 crores)

| Sl. No. | Milestone | Time Allowed (from date of start) in months | Amount to be withheld in case of non-achievement of mile stone |
|---------|-----------|---|--|
| 1. | | | |
| 2. | | | |
| 3. | | | |
| 4. | | | |

(xii) Competent authority to reschedule The milestones as per clause 34.5:-

Chairman, IWAI, Noida

(xiii) Competent authority for foreclosure of contract in full or in part due to abandonment or reduction in scope of work as per clause 31 :-

Engineer-in-Charge with the prior approval of
(a) Member Technical), IWAI (if the amount of contract is up to 100 lakhs).
(b) Vice-Chairman/Chairperson, IWAI, Noida (if the cost of the contract is more than 100 lakhs & up to 500 lakhs).
(c) Chairman, IWAI, Noida (if the amount of contract is more than 500 lakhs).

PART-II

GENERAL CONDITIONS OF CONTRACT

C O N T E N T S

| | |
|-----------|---|
| CLAUSE-1 | : DEFINITIONS |
| CLAUSE-2 | : INTERPRETATIONS |
| CLAUSE-3 | : SECURITY DEPOSIT FOR PERFORMANCE |
| CLAUSE-4 | : REFUND OF SECURITY DEPOSIT |
| CLAUSE-5 | : SUFFICIENCY OF TENDER |
| CLAUSE-6 | : CONTRACT DOCUMENTS |
| CLAUSE-7 | : DISCREPANCIES AND ADJUSTMENT OF ERRORS |
| CLAUSE-8 | : DUTIES AND POWERS OF ENGINEER-IN-CHARGE'S REPRESENTATIVE |
| CLAUSE-9 | : ASSIGNMENT AND SUB-LETTING |
| CLAUSE-10 | : FACILITIES TO OTHER CONTRACTORS |
| CLAUSE-11 | : CHANGE IN CONSTITUTION |
| CLAUSE-12 | : COMMENCEMENT OF WORK |
| CLAUSE-13 | : WORKS TO BE CARRIED OUT IN ACCORDANCE WITH SPECIFICATION DRAWINGS AND ORDERS ETC. |
| CLAUSE-14 | : SETTING OUT THE WORKS |
| CLAUSE-15 | : URGENT WORKS |
| CLAUSE-16 | : DEVIATIONS |
| CLAUSE-17 | : CONTRACTORS SUPERVISION |
| CLAUSE-18 | : INSTRUCTION AND NOTICE |
| CLAUSE-19 | : PLANT AND EQUIPMENT |
| CLAUSE-20 | : PATENT RIGHTS |
| CLAUSE-21 | : MATERIALS |
| CLAUSE-22 | : LAWS GOVERNING THE CONTRACT |
| CLAUSE-23 | : WATCHING AND LIGHTING |
| CLAUSE-24 | : WORK DURING NIGHT OR ON SUNDAYS AND HOLIDAYS |
| CLAUSE-25 | : LABOUR |
| CLAUSE-26 | : MATERIALS OBTAINED FROM EXCAVATION AND TREASURE TROVE, FOSSILS ETC. |
| CLAUSE-27 | : FORCE MAJEURE |
| CLAUSE-28 | : LIABILITY FOR DAMAGE, DEFECTS OR IMPERFECTIONS AND RECTIFICATION THEREOF |
| CLAUSE-29 | : CONTRACTOR'S LIABILITY AND INSURANCE |
| CLAUSE-30 | : SUSPENSION OF WORKS |
| CLAUSE-31 | : FORE CLOSURE OF CONTRACT IN FULL OR IN PART DUE TO ABANDONMENT OR REDUCTION IN SCOPE OF WORK |
| CLAUSE-32 | : TERMINATION OF CONTRACT ON DEATH |
| CLAUSE-33 | : CORRUPT PRACTICE & TERMINATION OF CONTRACT IN FULL OR IN PART |
| CLAUSE-34 | : COMPLETION TIME AND EXTENSIONS |
| CLAUSE-35 | : COMPENSATION FOR DELAY |
| CLAUSE-36 | : LIQUIDATED DAMAGES |
| CLAUSE-37 | : INSPECTION AND APPROVAL |
| CLAUSE-38 | : COMPLETION CERTIFICATE |
| CLAUSE-39 | : MEASUREMENTS |
| CLAUSE-40 | : PAYMENT ON ACCOUNT |
| CLAUSE-41 | : TAXES, DUTIES AND LEVIES ETC |
| CLAUSE-42 | : TAX DEDUCTION AT SOURCE |
| CLAUSE-43 | : PAYMENT OF FINAL BILL |
| CLAUSE-44 | : OVER PAYMENTS AND UNDER PAYMENTS |
| CLAUSE-45 | : CONTRACT MATTERS TO BE TREATED AS CONFIDENTIAL |
| CLAUSE-46 | : FINALITY CLAUSE |
| CLAUSE-47 | : SUM PAYABLE BY WAY OF COMPENSATION TO BE CONSIDERED IS REASONABLE WITHOUT PREFERENCE TO ACTUAL LOSS |
| CLAUSE-48 | : ARBITRATION |

PART - II

GENERAL CONDITIONS OF CONTRACT

CLAUSE - 1: DEFINITIONS

In the contract, the following words & expressions shall, unless context otherwise requires, have the meaning thereby respectively assigned to them:

- i) **Contract:** means the documents forming the tender and acceptance thereof and the formal agreement executed between the competent authority on behalf of the Chairman, Inland Waterways Authority of India and the contractor, together within the documents referred to therein including these conditions, the specifications, designs, drawings and instructions issued from time to time by the Engineer-in-charge and all these documents taken together shall be deemed to form one contract and shall be complementary to one another
- ii) **Contract sum;** means the amount arrived at by multiplying the quantities shown in the schedule of quantities and price by the respective item rates as allowed.
- iii) **Contractor:** means the successful tenderer who is awarded the contract to perform the work covered under this tender document and shall be deemed to include the contractor's successors, executors, representatives or assign approved by the Engineer-in-charge.
- (iv) **Employer** means the Chairman, Inland Waterways Authority of India and his successors.
- (v) **IWAI/ Authority/ Department/ Owner** shall mean the Inland Waterways Authority of India, which invites tenders on behalf of the Chairman, IWAI and includes therein-legal representatives, successors and assigns.
- (vi) **Engineer-In-Charge (EIC)** means the Engineer officer authorized to direct, supervise and be In-charge of the works for the purpose of this contract who shall supervise and be in charge of the work.
- (vii) **Engineer-in-charge representative** shall mean any officer of the Authority nominated by the Engineer-in-charge for day to day supervision, checking, taking measurement, checking bills, ensuring quality control, inspecting works and other related works for completion of the project.
- (viii) **Chairman:** means Chairman of Inland Waterways Authority of India.
- (ix) **Chief Engineer:** means the Chief Engineer of the Authority.
- (x) **Director** means the Director of the Authority, as the case may be.
- (xi) **Deputy Director** means the Deputy Director of the Authority, as the case may be.
- (xii) **Assistant Director** means the Asstt. Director of the Authority, as the case may be.
- (xiii) **Assistant Hydrographic Surveyor** means the Assistant Hydrographic Surveyor of the Authority, as the case may be

- (xiv) **Work Order** means a letter from the Authority conveying the acceptance of the tender/offer subject to such reservations as may have been stated therein.
- (xv) **Day** : means a calendar day beginning and ending at mid-night.
- (xvi) **Week** : means seven consecutive calendar days
- (xvii) **Month** : means the one Calendar month.
- (xviii) **Site** means the waterway and / or other places through which the works are to be executed.
- (xix) **Vessel** : means the vessel/craft belonging to the Contractor for carrying out the work.
- (xx) **Drawings** : means the drawings referred to in the specifications and / or appended with the tender document, any modifications of such drawings approved in writing by the Engineer-in-Charge and shall also include drawings issued for actual execution of the work time to time by the Engineer-in-Charge.
- (xxi) **Urgent Works**: means any urgent nature which in the opinion of the Engineer-In-Charge become necessary at the time of execution and / or during the progress of work to obviate any risk or accident or failure or to obviate any risk of damage to the vessel structure, or required to accelerate the progress of work or which becomes necessary for security or for any other reason the Engineer-in-Charge may deem expedient.
- (xxii) **Work/ works**: means work / works to be executed in accordance with the contract.
- (xxiii) Schedules referred to in these conditions shall mean the relevant schedules annexed to the tender papers or the standard schedule of rates of the govt. mentioned with the amendments thereto issued up to the date of receipt of the tender.
- (xxiv) District specifications mean the specifications followed by the State Government in the area where the work is to be executed.
- xxv) Tendered value means the value of the entire work as stipulated in the letter of award.

CLAUSE – 2 : INTERPRETATIONS

- 2.1 Words imparting the singular only shall also include the plural; he includes she and vice-versa unless this is repugnant to the context.

Heading and marginal notes in these General Conditions shall not be deemed to form part thereof or be taken into consideration in the interpretation of construction thereof of the contract.

CLAUSE – 3 : PERFORMANCE GURANTEE & SECURITY DEPOSIT

3.1 PERFORMANCE GURANTEE

The contractor shall be required to deposit an amount equal to 5% of the tendered value of the work as performance guarantee in the form of either RTGS/NEFT payable at any nationalized/schedule bank **OR** an irrevocable bank guarantee bond of any scheduled bank or State Bank of India in accordance with the form prescribed within 15 days of the issue of the work order.

3.2 SECURITY DEPOSIT

A sum @ 10% of the gross amount of the bill shall be deducted from each running bill of the contractor till the sum along with sum already deposited as earnest money will amount to security deposit of 5 % of the contract value of the work. Bank guarantee will not be accepted as security deposit.

- 3.3 The contractor whose tender is accepted has to enter into an agreement with IWAI for the due fulfillment of the contract. The security amount will be accepted in form of RTGS/NEFT only in favour of 'Inland Waterways Authority of India Fund SD & EMD' payable at PATNA.

a. The total performance guarantee/security deposit shall remain with IWAI till defect liability period after satisfactory completion of work.

b. Interest will not be paid on security deposit or performance guarantee.

c. If the contractor having been called upon by the Engineer in charge to furnish the security fails to do so within the specified period, the EMD submitted by the contractor shall be forfeited. It shall be lawful for the Employer:

- i) To recover the amount of balance security deposit by deducting the amount from the pending bills of the contractor under this contract or any other contract with the Authority, OR
- ii) To cancel the contract or any part thereof and to carry out the work or authorize to carry out the work/ works at the risk and cost of the contractor.

- 3.4 No claim shall lie against the authority either in respect of interest or any depreciation in value of any security.

- 3.5** If the contractor neglects to observe or fails to perform any of his obligations under the contract, it shall be lawful for the Employer/ EIC to forfeit either in whole or in part, the security deposit furnished by the contractor. However, if the contractor duly performs and completes the contract in all respects and presents in absolute "NO DEMAND CERTIFICATE" in the prescribed form, the IWAI shall refund the security deposit to the contractor after deduction of cost and expenses that the Authority may have incurred and other money including all losses and damages which the Authority is entitled to recover from the Contractor.
- 3.6** In case of delay in the progress of work, the Engineer- in-Charge shall issue to the contractor a memo in writing pointing out the delay in progress and calling upon the contractor to explain the causes for the delay within 3 days of receipt of the memo and 10 days from issuance of memo whichever is earlier. If the Engineer-in-Charge is not satisfied with the explanations offered, he may forfeit the security deposit and / or withhold payment of pending bills in whole or in part and/ or get the measures of rectification of progress of work accelerated to the pre-defined level at the risk and cost of the contractor.
- 3.7** All compensation or other sums of money payable by the contractor under the terms of the contract or any other contract or on any other account whatsoever, may be deducted from or paid by the sale of a sufficient part of his security or from the interest arising there from or from any sums which may be due or may become due to the contractor by the Authority on any account whatsoever. Also in the event of the contractor's security deposit being reduced by reasons of such deductions or sale, as aforesaid the contractor shall, within 14 days of receipt of notice of demand from the Engineer-in-Charge make good the deficit in his security deposit.

CLAUSE – 4 : REFUND OF SECURITY DEPOSIT & DEFECT LIABILITY PERIOD

4.1 REFUND OF SECURITY

The security deposit less any amount due shall, on demand, be returned to the contractor on the expiry of defects liability period or on payment of the amount of the final bill payable in accordance with the agreement conditions, whichever is later, provided the engineer-in-charge is satisfied that there is no demand outstanding against the contractor.

4.2 DEFECT LIABILITY PERIOD

The contractor shall be responsible to make good and remedy, at his cost, within such period as may be stipulated by the Engineer-in-Charge. Any defects which may be developed or may be noticed before the expiry of the period mentioned from the certified date of completion of the entire work (including and comprising of all the group, sub-groups of works, if any) covered under the contract.0

CLAUSE – 5 : SUFFICIENCY OF TENDER

The contractor shall be deemed to have satisfied himself before tendering as to the correctness and sufficiency of his tender for the works and of the rates quoted in the schedule of Quantities and Prices which shall (except as otherwise provided in the contract) cover all his obligations under the contract and all matters and things necessary for the proper execution and completion of the works in accordance with the provisions of the

contract and its operation during execution of work.

CLAUSE – 6 : CONTRACT DOCUMENTS

- 6.1 The language in which the contract documents shall be drawn up shall be English and if the said documents are written in more than one languages, the language according to which the contract is to be constructed and interpreted shall be English and designated as the 'Ruling Language'.
- 6.2 The Contractor shall be furnished free of charge certified true copy of the contract document.
- 6.3 A copy of the Contract Documents furnished to the contractor as aforesaid shall be kept by the contractor on the site in good order and the same shall at all reasonable time be available for inspection and use by the Engineer-in-Charge, his representatives or by other inspecting officers of the authority.
- 6.4 None of these documents shall be used by the contractor for any proposed other than that of this contract.

CLAUSE – 7 : DISCREPANCIES AND ADJUSTMENT OF ERRORS

- 7.1 Figured dimensions in preference to scaled dimensions. The case of discrepancy between the Schedule of Quantities and prices, the Specifications and/ or the drawings, the following order of precedence shall be observed : -
 - (a) Description in the Schedule of Quantities and Prices.
 - (b) Relevant Specifications and Special Conditions, if any.
 - (c) Drawings.
 - (d) General Specifications.
- 7.2 The contractor shall study and compare the drawings, specifications and other relevant information given to him by the Engineer-in-Charge and shall report in writing to the Engineer-in-Charge any discrepancy and inconsistency which he notes. The decision of the Engineer-in-Charge regarding the true intent and meaning of the drawings and specifications shall be final and binding.
- 7.3 Any error in description, quantity or price in Schedule of Quantities and Prices or any omission there from shall not vitiate the Contract or release the Contractor from the execution of the whole or any part of the Works comprised therein according to drawings and specifications or from any of his obligations under the contract.
- 7.4 If on check there is difference in the amount worked out by contractor in the schedule of quantities and prices and General summary the same shall be adjusted in accordance with the following rules:
 - (a) In the event of error occurring in the amount column of schedule of quantities and prices as result of wrong multiplication of unit price and quantity, the unit price shall be regarded, as firm and multiplication shall be amended on the basis of the quoted unit price.
 - (b) All errors in totaling in the amount column and in carrying forward totals shall be corrected.

- (c) The totals of various sections of schedule of quantities and price amended shall be carried over to the General Summary and the tendered sum amended accordingly. The tendered sum so altered shall, for the purpose of tender, be substituted for the sum originally tendered and considered for acceptance instead of the original sum quoted by the tenderer. Any rounding off of quantities or in sections of schedule of quantities and prices or in General summary by the tenderer shall be ignored.

CLAUSE-8: DUTIES AND POWERS OF THE ENGINEER-IN-CHARGE REPRESENTATIVE

- 8.1 The duties of the representative of the Engineer-in-Charge are to watch and supervise the works and to test and examine any materials/ parts to be used or workmanship employed in connection with the works.
- 8.2 The Engineer-in-Charge may, from time to time in writing, delegate to his representative any of the powers and authorities, vested in the Engineer-in- Charge and shall furnish to the contractor a copy of all such written delegation of powers and authorities. Any written instruction or written approval given by the representative of the Engineer-in-Charge to the contractor within the terms of such delegation shall bind the contractor and the Authority as though it has been given by the Engineer-in-Charge.
- 8.3 Failure of the representative of the Engineer-in-Charge to disapprove any work or materials shall be without prejudice to the power of the Engineer-in-Charge thereafter to disapprove such work or materials and to order the pulling down, removal or breaking up thereof. The contractor shall, at his own expense, again carry out such works as directed by the Engineer-in-Charge.
- 8.4 If the Contractor is dissatisfied with any decision of the representative of the Engineer-in-Charge, he will be entitled to refer the matter to the Engineer-in- Charge who shall thereupon confirm, reverse or vary such decision and the decision of the Engineer-in-Charge in this regard shall be final and binding on the contractor.

CLAUSE – 9: ASSIGNMENT AND SUB-LETTING

The Contractor shall not sub-let, transfer or assign the whole or any part of the work under the contract. Provided that the Engineer-in-Charge may at his discretion, approve and authorize the Contractor to sub-let any part of the work, which in his opinion, is not substantial, after the contractor submits to him in writing the details of the part of the work(s) or trade proposed to be subject, to name of the sub-contractor thereof together with his past experience in the said work/trade and the form of the proposed sub-contract. Nevertheless any such approval or authorization by the Engineer-in-Charge shall not relieve the contractor from his any or all liabilities, obligations, duties and responsibilities under the contract. The contractor shall also be fully responsible to the Authority for all the acts and omissions of the sub-contractor, his employees and agents or persons directly employed by the contractor. However, the employment of piece rate works shall not be construed as sub-letting.

CLAUSE – 10: FACILITIES TO OTHER CONTRACTORS

The contractors shall, in accordance with the requirements of the work as decided by the

Engineer-in- Charge, afford all reasonable facilities to other contractors engaged contemporaneously on separate contracts and for departmental labour and labour of any other agency properly authorized by Authority or any statutory body which may be employed at the site for execution of any work not included in the contract which the Authority may enter into in connection with or ancillary to the works. In all matters of conflict of interest, the Engineer-in-Charge shall direct what compromise should be made and his decision shall be final and binding on the parties.

Clause – 11 : CHANGE IN CONSTITUTION

Where the contractor is a partnership firm, prior approval in writing of the Engineer-in-Charge shall be obtained before any change is made in the constitution of the firms, where the contractor is an individual or a Hindu Undivided Family business concern, such approval, as aforesaid, shall like-wise be obtained before the contractor enters into any partnership firm which would have the right to carry out the work undertaken by contractor. If prior approval as aforesaid is not obtained the contractor shall be deemed to have been assigned in contravention to Clause 32 hereof and the same action will be taken and the same consequences shall ensure as provided for in the said clause-33.

CLAUSE – 12 : COMMENCEMENT OF WORK

The contractor shall commence the work at the respective sites within 10 days of the issue of Letter of Award. If the contractor commits default in mobilization of resources, and equipment as aforesaid, the Engineer-in-Charge shall without prejudice to any other right or remedy be at liberty to cancel the contract and forfeit the earnest money/security deposit.

CLAUSE – 13 : WORKS TO BE CARRIED OUT IN ACCORDANCE WITH SPECIFICATION DRAWINGS AND ORDERS ETC.

- 13.1 The contractor shall execute the whole and every part of the work in the most substantial and workman like manner and both as regards material and otherwise in every respect in strict conformity with the specification laid down or as may be laid down by the Engineer-in-Charge under the terms of the contract. The contractor shall also conform exactly, fully and faithfully to the designs, drawings specifications and instructions in writing in respect of the work, duly signed by the Engineer-in-Charge as may be issued from time to time.
- 13.2 The contractor shall be entitled to receive, on demand, in addition to the contract documents, in accordance with the provisions of contract, the documents set forth herein in respect of the work on commencement or during the performance of the contract:
- (a) Specifications or revisions thereof other than standard printed specifications
 - (b) Explanations, instructions etc.

Such further drawings, explanation, modifications and instruction, as the Engineer-in-Charge may issue to the contractor from time to time in respect of the work shall be deemed to form integral part of the contract and the contractor shall be bound to carry out the work accordingly.

- 13.3 All instructions and orders in respect of the work shall be given by the Engineer-in-Charge in writing. However, any verbal instructions or order shall be confirmed by the Engineer-in-Charge as soon as practicable without loss of time and only such written instruction shall

be deemed to be valid.

CLAUSE – 14 : SETTING OUT THE WORKS

The contractor shall provide all assistance and adhere to the instruction of E.I.C during the course of surveying, inspection, etc.

CLAUSE – 15 : URGENT WORKS

If any urgent work (in respect where the decision of the Engineer-in-Charge shall be final and binding) becomes necessary, the contractor shall execute the same as may be directed, provided the directions are in accordance and confirmatory with provisions in Clause – 8.

CLAUSE – 16: DEVIATIONS

- 16.1 The Engineer-in-Charge shall have powers to make any deviations in the original specifications of the works or any part thereof that are in his opinion, necessary at the time of or during the course of execution of the works for the aforesaid purpose or for any other reason, if it shall, in the opinion of the Engineer-in-Charge, be desirable, he shall also have the powers to make Deviations, such as (i) Variations (ii) Extra (iii) Additions / Omissions and (iv) Alterations or Substitutions of any kind. No such Deviations in the specification or drawings or designs or Schedule of Quantities, as aforesaid, shall in any way vitiate or invalidate the contract and any such Deviations which the contractor may be directed to do shall form integral part of the contract as if originally provided therein and the contractor shall carry out the same on the same conditions in all respects on which he agreed to do the works under the contract. However, such deviation for individual item shall be limited to \pm 10% but the total value of the contract should not exceed 10%
- 16.2 Such items of work, as are required, to be executed at the rates already provided in the schedule of quantities, shall apply in respect of the same item(s) of work to be executed due to Variation.
- 16.3 If requested by the contractor the time for completion of the work shall, in the event of any deviation resulting in additional cost over the contract sum be extended in the proportion which altered, additional or substituted work bears to the original contract sum plus such further additional time as may be considered reasonable by the Engineer-in-Charge whose decision shall be conclusive as to such provision:
- 16.4 Under the circumstances, the contractor shall at any stage not suspend the work on account of non-settlement of rates of such Deviated items.

CLAUSE - 17: CONTRACTORS SUPERVISION

- 17.1 The contractor shall either himself supervise the execution of the works or shall appoint at his own expense, an Engineer as his accredited agent approved by the Engineer-in-Charge, if contractor has himself not sufficient knowledge or experience to be capable of receiving instruction or cannot give his full attention to the works. The contractor or his agent shall be present at the site(s) and shall superintend the execution of the works with such additional assistance in each trade, as the work involved shall require and considered reasonable by the Engineer-in-Charge, directions/instructions given by the Engineer-in-Charge to the contractor's agent shall be considered to have the same force as if these had

been given to the contractor himself.

- 17.2 If the contractor fails to appoint a suitable agent as directed by the Engineer-in-Charge, the Engineer-in-Charge shall have full powers to suspend the execution of the works until such date as a suitable agent is appointed by the contractor and takes over the supervision of the work. For any such suspension, the contractor shall be held responsible for delay so caused to the works.

CLAUSE - 18: INSTRUCTION AND NOTICE

- 18.1 Except as otherwise provided in this contract, all notices to be given on behalf of the Authority and all other actions to be taken on its behalf may be given or taken by the Engineer-in-Charge or any officer for the time being entrusted with the functions duties and powers of the Engineer-in-Charge.
- 18.2 All instructions, notices and communications etc. under the contract shall be given in writing and any such oral orders / instructions given shall be confirmed in writing and no such communication which is not given or confirmed in writing shall be valid.
- 18.3 All instructions, notices and communications shall be deemed to have been duly given or sent to the contractor, if delivered to the contractor, his authorized agent, or left at, or posted to, the address given by the contractor or his authorized agent or to the last known place of abode or business of the contractor or his agent of services by post shall be deemed to have been served on the date when in the ordinary course of post these would have been delivered to him and in other cases on the day on which the same were so delivered or left.
- 18.4 The Engineer-in-Charge shall communicate or confirm the instructions to the contractor in respect of the execution of work in a work site order book maintained in the office of the Engineer-in-Charge and the contractor or his authorized representative shall confirm receipt of such instructions by signing the relevant entries in this book. If required by the Contractor, he shall be furnished a certified true copy of such instruction(s).

CLAUSE -19: PLANT AND EQUIPMENT

- 19.1 The Contractors shall provide and install all necessary plant; equipment and machinery required for the execution of the work under the contract, at his cost and shall use such methods and appliances for the purpose of all the operations connected with the work covered by the contract, which shall ensure the completion of work(s) within the specified time.
- 19.2 Subject to the availability of any item(s), plant, equipment and machinery the Authority at the written request of the contractor, may issue to the contractor on hire for being deployed on the work contracted for, at pre- determined rates, terms and conditions at the sole discretion of the Engineer-in-Charge.

CLAUSE – 20: PATENT RIGHTS

The contractor shall indemnify the Authority, its representatives or its employees

against any action, claim or proceeding relating to infringement or use of any patent or design or any alleged patent or design rights and shall pay any royalties or other charges which may be payable in respect of any article or material or part thereof included in the contract. In the event of any claim being made or action being brought against the Authority or any agent, servant or employee of the Authority in respect of any such materials as aforesaid the contractor shall immediately be notified thereof. Provided that such indemnity shall not apply when such infringement has taken place in complying with the specific directions issued by the Authority but the contractor shall pay any royalties or other charges payable in respect of any such use, the amount so paid being reimbursement to the contractor only if the use was the result of any drawings and or specifications issued after submission of the tender.

CLAUSE – 21: MATERIALS

- 21.1 The contractor shall at his own expenses provide / arrange all materials required for the bonafide use on work under the contract.
- 21.2 All materials parts to be provided by the contractor shall be in conformity with the specifications laid down in the contract and the contractor shall furnish from time to time proof and samples, at his cost, of the materials parts as may be specified by the Engineer-in-Charge shall also have powers to have such tests, in addition to those specified in the contract, as may be required and the contractor shall provide all facilities to carry out the same. The cost of materials parts consumed in such tests and also expenses incurred thereon shall be borne by the contractor in all cases and also where such tests which are in addition to those provided in the contract disclose that the materials are in conformity with the provisions of the contract.
- 21.3 The Engineer-in-Charge or his representative shall be entitled at any time to inspect and examine any materials parts intended to be used in or the works, either on the site or at factory or workshop or other place(s) where such materials are assembled, fabricated, manufactured or any place where these are lying or from where these are being obtained. For this, purpose, the contractor shall afford such facilities as may be required for such inspection and examination.

CLAUSE - 22: LAWS GOVERNING THE CONTRACT

The Courts at PATNA only shall have the jurisdiction for filing the award of the arbitration and for any other judicial proceedings.

CLAUSE - 23: WATCHING AND LIGHTING

The Contractor shall provide and maintain at his expense all lights, guards, fencing and watching when and where necessary or as required by the Engineer-in- Charge for the protection of the works or for the safety and convenience of those employed on the works or the public.

CLAUSE - 24: WORK DURING NIGHT OR ON SUNDAYS AND HOLIDAYS

- 24.1 Subject to any provisions to the contrary contained in the contract, none of the works shall be carried out during national holidays without the permission in writing of the Engineer-in-Charge. However, when work is unavoidable or necessary for safety of life, property or works, contractor shall take necessary action immediately and advise the Engineer-in-Charge accordingly.

24.2 The Engineer-in-Charge at its discretion may, however, direct the contractor that the work may be carried out on holidays, Sundays and/ or extra shifts to ensure completion of works under the contract as scheduled.

CLAUSE - 25 : LABOUR

25.1 (a) The contractor shall employ labour in sufficient numbers to maintain the required rate of progress and of quality to ensure workmanship of the degree specified in the contract and to the satisfaction of the Engineer-in-Charge. The Contractor shall not employ in connection with the works any person who has not completed eighteen years of age the minimum age specified in Indian Labour Law.

(b) If any foreigner is employed by the contractor to work within the site the later shall ensure that such foreigner possesses the necessary special permit issued by the civil Authorities in writing and also comply with the instructions issued therefore from time to time. In the event of any lapse in this regard on the part of such foreigner the contractor shall be personally held responsible for the lapse & Authority shall not be liable in any event.

(c) The Contract is liable for cancellation if either the contractor himself or any of his employee is found to be a person who has held Class-I post under the Authority immediately before retirement and has within two years of such retirement accepted without obtaining the previous permission of the Authority or of the Chairman as the case may be and employment as contractor for, or in connection with the execution of the public works, or as an employee of such contractor. If the contract is terminated on account of the failure of the contractor to comply with the above clause, the Authority shall be entitled to recover from him such damages as may be determined by the Engineer-in-Charge with due regard to the inconvenience caused to the Authority on account of such termination without prejudice to the Authority's right to proceed against such officer.

25.2 The contractor shall furnish and deliver fortnightly to the Engineer-in-Charge, a distribution return of the number and description by trades of the works of people employed on the works. The contractor shall also submit on the 4th and 19th of every month for the period of second half of the preceding month and first half of the current month respectively to the Engineer-in-Charge, a true statement in respect of the following.

i) Any accidents if occurred during the said fortnight showing the circumstances under which they happened and the extent of damage and injury caused by them and.

ii) the number of female workers who have been allowed maternity benefit as provided in the Maternity Benefit Act 1961 or Rules made thereunder and the amount paid to them.

25.3 The Contractor shall pay to labourer employed by him either directly or through sub-contractors wages not less than wages as defined in Minimum Wages Act and amendments made from time to time.

25.4 The Contractor shall in respect of labour employed by him either directly or though sub-contractor comply with or cause to be complied with the contract labour (Regulation and

Abolition) Act 1970 and Rules framed there under in regard to all matters provided therein.

25.5 The Contractor shall comply with the provision of all the Acts Laws, any Regulation or Bye Laws of any Local or other Statutory Authority applicable in relation to the execution of works such as :

- i) Payment of Wages Act, 1936 (Amended)
- ii) Minimum Wages Act, 1948 (Amended).
- iii) The Contract Labour (Regulation & Abolition) Act, 1970 with Rules framed there under as amended.
- iv) Workmen Compensation Act, 1923 as amended by Amendment Act no.65 of 1976.
- v) Employer's Liability Act 1938 (Amended)
- vi) Maternity Benefit Act. 1961 (Amended)
- vii) The Industrial Employment (Standing orders) Act 1946 (Amended).
- viii) The Industrial Disputes Act. 1947 (Amended)
- ix) Payment of Bonus Act.1965 and Amended Act No. 43 of 1977 and No. 48 of 1978 and any amended thereof:
- x) The Personal Injuries (Compensation Insurance) Act 1963 and any modifications thereof and rules made there under from time to time. The Contractor shall take into account all the above and financial liabilities in his quoted rates and nothing extra, whatsoever, shall be payable to him on this account.
- xi) State Inland Vessel Rules as applicable

25.6 The Contractor shall be liable to pay his contribution and the employees contribution to the State Insurance Scheme in respect of all labour employed by him for the execution of the contract, in accordance with the provision of "the Employees State insurance Act 1948" as amended from time to time. In case the Contractor fails to submit full details of his account of labour employed and the contribution payable the Engineer-in- Charge shall recover from the running bills of the contribution an amount of contribution as assessed by him. The amount so recovered shall be adjusted against the actual contribution payable for Employees State Insurance.

25.7 The Engineer-in-Charge shall on a report having been made by an inspecting officer as defined in the Contract Labour (Regulation and Abolition) Act and Rules or on his own in his capacity as Principal Employer, have the power to deduct from the amount due to the contractor any sum required on estimated to be required for making good the loss suffered by worker(s) by reason of non-fulfillment of the conditions of the Contract for the benefit of Workers, nonpayment of wages or of deduction made from him for wages which are not justified by the terms of the contract or non- observance of the said Act and Rules framed there under with amendments made from time to time.

25.8 The Contractor shall indemnify the Authority against any payments to be made under and for observance of the Regulation Laws, Rules as stipulated in Clause-25.5 above without

prejudice to his right to claim indemnity from his sub-contractors. In the event of the contractor's failure to comply with the provisions of all the Act/Laws stipulated in Clause-25.5 or in the event of decree or award or order against the contractor having been received from the competent authority on account of any default or breach or in connection with any of the provisions of the Act/Law/Rules mentioned in Sub-Clause 25.5 above, the Engineer-in-Charge without prejudice to any other right or remedy under the contract shall be empowered to deduct such sum or sums from the Bill of the contractor or from his security deposit or from other payment due under this contract or any other contract to satisfy within a reasonable time the provisions of the various Act/Laws/Rules/Codes as mentioned under Sub-Clause 25.5 above, on the part of the contractor under the contract on behalf of and at the expenses of the contractor and make payment and /or provide amenities/facilities/services accordingly. In this regard, the decision of the Engineer-in-Charge shall be conclusive and binding on the contractor.

- 25.9 In the event or the Contractor committing a default or breach of any of the provisions of the aforesaid Contract's Labour (Regulation and Abolition) Act and Rules as amended from time to time or furnishing any information or submitting or filling any form/Register/Slip under the provisions of these Regulations which is materially incorrect then on the report of the Inspecting officer as defined in the relevant Acts and Rules as referred in Clause 25.5 above, the Contractor shall without prejudice to any other liability pay to the Authority a sum not exceeding Rs.50/- (Rs. Fifty only) as liquidated damages for every default, breach or furnishing, making, submitting, filling materially incorrect statement as may be fixed by the Engineer-in-Charge. The decision of the Engineer-in-Charge in this respect shall be final & binding.
- 25.10 The Contractor shall at his own expenses Comply with or cause to be complied with the Provisions/ Rules provided for welfare and health of Contract Labour in the Contract Labour (Regulation and Abolition) Act and other relevant Acts and Rules framed there under or any other instructions issued by the Authority in this regard for the protection of health and for making sanitary arrangements for workers employed directly or indirectly on the works. In case the contractor fails to make arrangements as aforesaid, the Engineer-in-Charge shall be entitled to do so and recover the cost thereof from the contractor.
- 25.11 The Contractor shall at his own expense arrange for the safety or as required by the Engineer-in-Charge, in respect of all labour directly or indirectly employed for performance of the Works and shall provide all facilities in connection therewith. In case the contractor fails to make arrangements and provide necessary facilities as aforesaid, the Engineer-in-Charge shall be entitled to do so and recover the cost thereof from the Contractor. But this will not absolve the contractor of his responsibility or otherwise thereof.
- 25.12 Failure to comply with "Provisions/Rules made for Welfare and Health of Contract Labour" Safety Manual, or the provisions relating to report on accidents and grant of maternity benefits to female workers and the relevant Act/Rules referred in clause 25.5 above shall make the contractor liable to pay to the Authority as liquidated damages an amount not exceeding Rs. 50/- for each default or materially incorrect statement. The decision of the Engineer-in-Charge in such matters based on reports from the inspecting Officers as defined in the relevant Acts and Rules as referred in clause 25.5 above shall be final and binding and deductions for recovery of such liquidated damages may be made from any amount payable to the contractor. In the event of any injury, disability or death of

any workmen in or about the work employed by the contractor either directly or through his sub-contractor, contractor shall at all time indemnify and save harmless the Authority against all claims, damages and compensation under the Workmen Compensation Act, 1923 as amended from time to time or in other Law for the time being in force and Rules there-under from time to time and also against all costs, charges and expenses of any smooth action by proceedings arising out of such accidents or injury, disability or death of a workmen and against all sum or sums which may with the consent of the contractor be paid to compromise or compound any claim in this regard. If any award, decree or order is passed against the contractor for recovery of any compensation under the Workmen Compensation Act, 1923, for any injury, disability or death of a workman by any competent court, the said sum or sums shall be deducted by the Engineer-in-Charge from any sum then due or that may become due to the contractor or from his security deposit or sale thereof in full or part under the contract or any other contract with the Authority towards fulfillment of the said decree, award or orders.

25.13 Provided always that the contractor shall have no right to claim payments/claims whatsoever on account of his compliance with his obligations under this clause and Labour Regulation.

25.14 ALCOHOLIC LIQUOR OR DRUGS.

The contractor shall not otherwise than in accordance with the statutes ordinance and Government Regulations or orders for the time being in force import, sell, give, barter or otherwise dispose of any alcoholic liquor or drugs to permit or suffer any such import, sale, gift, barter or disposal by his sub-contractor, agent or employees.

25.15 ARMS AND AMMUNITION

The contractor shall not give, barter or otherwise dispose of to any person or persons any arms or ammunition of any kind or permit to suffer the same as aforesaid.

25.16 REMOVAL OF CONTRACTOR'S MEN

The Contractor shall employ for the execution of the works only such persons as are skilled and experienced in their respective trades and Engineer-in-Charge shall be at liberty to object to and require the contractor to remove from the works any persons employed by the Contractor for the execution of the works who, in the opinion of the Engineer-in-Charge, misconduct himself or is incompetent or negligent in the proper performance of his duties. The contractor shall forthwith comply with such requisition and such person shall not be again employed upon the works without permission of the Engineer-in-Charge.

CLAUSE – 26 : MATERIALS OBTAINED FROM EXCAVATION AND TREASURE TROVE, FOSSILS, ETC.

26.1 Materials of any kind obtained from excavation on the site shall remain the property of the Authority and shall be disposed off as directed by the Engineer-in-Charge.

26.2 However if any of the materials thus obtained from excavation on the site is such as can be used in the execution of the work under the contract, the contractor will be allowed to use

the same free of cost (except that any amount of royalty paid for in this regard by the Authority shall be recoverable from the contractor) for the aforesaid purpose provided the same is found suitable and is approved by the Engineer-in-Charge.

- 26.3 Fossils, coins, articles of value, structures and other remains or things of geological or archeological interest discovered on the site shall be the absolute property of the Authority. The contractor shall take reasonable precautions to prevent his labour or any other person from removing or damaging any such article or thing and shall acquaint the Engineer-in-Charge with such discovery and carryout the Engineer-in-Charge's directions as to the disposal of the same at the expense of the Authority.

CLAUSE – 27: FORCE MAJEURE

- 27.1 The term Force Majeure shall herein mean Riots (other than among the contractor's employees), Civil Commotion (to the extent no insurable), war (whether declared or not), invasion, act of foreign enemies, hostilation, civil war, rebellion, revolution, insurrection, military or usurped power, damage from aircraft, nuclear fission, acts of God, such as earthquake (above 7 magnitude on Richter Scale), lightning, unprecedented floods, fires not caused by contractor's negligence and other such causes over which the contractor has no control and are accepted as such by the Engineer-in-Charge, whose decision shall be final and binding. In the event of either party being rendered unable by Force Majeure to perform any obligation required to be performed by them under this contract, the relative obligation of the party affected by such Force Majeure shall be treated as suspended for the period during which such Force Majeure cause lasts, provided the party allowing that it has been rendered unable as aforesaid, thereby shall notify within 15 days of the alleged beginning and ending thereof giving full particulars and satisfactory evidence in support of such cause.
- 27.2 For delays arising out of Force Majeure, the bidder shall not claim extension in completion date for a period exceeding the period of delay attributable to the causes of Force Majeure and neither the Authority nor the bidder shall be liable to pay extra costs provided it is mutually established that Force Majeure conditions did actually exist.
- 27.3 If any of the Force Majeure conditions exists in the places of operation of the bidder even at the time of submission bid, he shall categorically specify in his bid and state whether they have been taken into consideration in their quotations.

CLAUSE - 28 : LIABILITY FOR DAMAGE, DEFECTS OR IMPERFECTIONS AND RECTIFICATION THEREOF

- 28.1 If the contractor or his labour or sub-contractor, injure, destroy or damage, battery, solar panel, lighting system, road, fence, enclosures, water pipe, cables, buildings, drains, electricity or telephone posts, wires, trees, grass line, cultivated land in the area in which they may be working or in the area contiguous to the premises on which the work or any part of it is being executed or if any damage is caused during the progress of work, the Contractor shall upon receipt of a notice in writing in that behalf from the Engineer-in-

Charge, make good the same at his cost.

- 28.2 If it appears to the Engineer-in-Charge or his representative at any time during to or prior to the expiration of the Defects Liability period that any work has been executed with unsound, imperfect or unskilled workmanship or that any materials or articles provided by the Contractor for execution of the work are unsound or of a quality inferior to that contracted for, or otherwise not in accordance with the Contract, or that any defect, shrinkage or other faults found in the work arising out of defective or improper materials or workmanship, the Contractor shall, upon receipt of a notice in writing in that behalf from the Engineer-in- Charge forthwith rectify or remove and reconstruct the work so specified in whole or in part, as the case may be, and/or remove the materials/articles so specified and provide other proper and suitable materials at his expense.
- 28.3 All damages caused by accidents or carelessness of the contractor or any of his employees or any property belonging to the Authority is wasted or is misused by the contractor or any of his employees shall be to the account of the contractor, who shall make good the loss.

CLAUSE – 29 : CONTRACTOR'S LIABILITY AND INSURANCE

- 29.1 From commencement to completion of the work(s) as a whole, the Contractor shall take full responsibility for the care thereof and for taking precautions to prevent loss or damage. He shall be liable for any damage or loss that may happen to the works or any part thereof and to the Authority's Plant, Equipment and Material (hired or issued to the Contractor) shall be in good order and condition and in conformity in every respect with the requirements of the Contract and instructions of the Engineer-in-Charge.
- 29.2 i) Neither party to the contract shall be liable to the other in respect of any loss or damage which may occur or arise out of "Force Majeure" to the works or any part thereof on to any material or article at site but not incorporated in the works or to any person or anything or material whatsoever or either party provided such a loss or damage could not have been foreseen or avoided by a prudent person and the either party shall bear losses and damages in respect of their respective men and materials. As such liability of either party shall include claims/ compensations of the third party also.
- ii) Provided, however, in an eventuality as mentioned in sub-clause - 29.2 (i) above, the following provisions shall also have effect :
- (a) The Contractor shall, as may be directed in writing by the Engineer-in-Charge proceed with the completion of the works under and in accordance with the provisions and conditions of the contract, and
- (b) The Contractor shall, as may be directed in writing by the Engineer-in-charge, re-execute the works lost or damaged, remove from the site any debris and so much of the works as shall have been damaged and carry the Authority's T & P, Plant and Equipment, Material etc. to the Authority's store. The cost of such re-execution of the works, removal of damaged works and carrying of Authority's store shall be ascertained in the same manner as for deviations and this shall be added to the contract sum. Provided always that the Contractor shall, at his own cost, repair and make good so much of the loss or damage as has been occasioned by any failure on his part to

perform his obligations under the contract or not taking precautions to prevent loss or damage or minimize the amount of such loss or damage, Final assessment of loss or damage shall be decided by the Engineer-in-Charge and his decision shall be final and binding.

- 29.3 The contractor shall take special precautions to see that public places and roads adjacent to contractor's yard are not blocked at anytime either by his material or by his workmen. The roads are to be kept always clear and no equipment/materials shall be stacked.
- 29.4 The navigable waterways shall not be blocked by Contractor's vessels. The anchors dropped in the waterways shall be properly marked and removed after done with.
- 29.5 The contractor shall indemnify and keep indemnified the Authority against all losses and claims for death, injuries or damage to any person or any property whatsoever which may arise out of or in consequence of the construction and maintenance, of works during the contract period and also against all claims, demands, proceedings, damages, costs, charges and expenses whatsoever in respect of or in relation thereto, and such liabilities shall include claims/compensations of the third party.
- 29.6 (a) Before commencing execution of the work, the Contractor shall without in any way limiting his obligations and responsibilities under this condition, insure against any damage, loss or injury which may occur to any property (excluding that of the Authority but including the Authority building rented to the contractor wholly or in part and any part of which is used in part and any part of which is used by him for storing combustible materials) public liability by arising out of the carrying out of the contract. For this purpose the contractor shall take out, pay all costs and maintain throughout the period of his contract public liability with the following coverage.
- i) Public liability limits for bodily injury or death not less than Rs. 1,00,000/- for one person and Rs. 2,00,000/- for each accident.
 - ii) Property liability limits for each accident not less than Rs. 1,00,000/-.
 - iii) The Contractor shall prove to the Engineer-in Charge from time to time that he has taken out all the insurance policies referred to above and has paid the necessary premiums for keeping the policies alive till expiry of the Defects Liability Period.
- (b) The Contractor shall ensure that similar insurance policies are taken out by his sub-contractor (if any) and shall be responsible for any claims or losses to the Authority resulting from their failure to obtain adequate insurance protection in connection thereof. The Contractor shall produce or cause to be produced by his sub-contractors (if any) as the case may be, relevant, policy or policies and premium receipt as and when required by the Engineer-in-Charge.
- (c) If the contractor and/or his sub- contractor (if any) shall fail to effect and keep in force the insurance referred to above or any other insurance which he/they may be required to effect under the term of the Contract then and in any such case the Authority may, without being bound to effect and keep in force any such insurance and pay such premium or premiums as may be necessary for that purpose and from

time to time deduct the amount so paid by the Authority from any moneys due or which may become due to the contractor or recover the same as a debt due from the contractor.

- (d) The contractor shall at his own expense arrange for the safety provisions as required in respect of the works covered under this contract as per the instruction of Engineer-in-charge. In case, the contractor fails to comply with the provisions of the safety the Engineer- in-Charge shall be entitled to and make the necessary arrangements at the risk and cost of the contractor. This will, however, not absolve the Contractor of his overall responsibility to execute the works under the contract.

CLAUSE – 30 : SUSPENSION OF WORKS

- 30.1 The contractor shall on the order of the Engineer-in-Charge suspend the progress of the works or any part thereof for such time or times and in such manner as the Engineer-in-Charge may consider necessary and shall during such suspension properly protect and secure the work so far as is necessary in the opinion of the Engineer-in-Charge.

CLAUSE – 31: FORECLOSURE OF CONTRACT IN FULL OR IN PART DUE TO ABANDONMENT OR REDUCTION IN SCOPE OF WORK

If at any time after acceptance of the tender the Authority decides to abandon or reduce the scope of the works for reason whatsoever and hence does not require the whole or any part of the works to be carried out, the Engineer-in-Charge shall give notice in writing to that effect to the contractor and the Contractor shall have no claim to any payment of compensation or otherwise whatsoever, on account of any profit or advantage which he might have derived from the execution of the works in full but which he could not derive in consequence of the fore closure of the whole or part of the works.

CLAUSE – 32: TERMINATION OF CONTRACT ON DEATH

If the Contractor is an individual or a proprietary concern and the individual or the proprietor dies, or if the Contractor is a partnership concern and one of the partners dies, then, unless the Engineer-in-Charge is satisfied that the legal representatives of the individual contractor or of the proprietor of the proprietary concern and in the case of partnership, the surviving partners are capable of carrying out and completing the contract, the Engineer-in-Charge shall be entitled to terminate the Contract as to its incomplete part without the Authority being in anyway liable to payment of any compensation whatsoever on any account to the estate of the deceased Contractor and/or to the surviving partners of the Contractor's firm on account of termination of the Contract. The decision of the Engineer-in-Charge that the legal representatives of the deceased contractor or the surviving partners of the Contractor's firm cannot carry out and complete the works under the contract shall be final and binding on the parties. In the event of such termination, the Authority shall not hold the estate of the deceased Contractor and/or the surviving partners of the Contractor's firm liable for damages for not completing the contract. Provided that the power of the Engineer-in-Charge of such termination of contract shall be without prejudice to any other right or remedy which shall have accrued or shall accrue to him under the contract.

CLAUSE– 33 : CORRUPT PRACTICE & TERMINATION OF CONTRACT IN FULL OR IN PART

33.1 If the contractor -

- i) commits default in complying with or commits breach of any of the terms and conditions of the contract and does not remedy it or take effective steps to remedy it immediately and not later than 10 days in any case after a notice in writing is given to him in that behalf by the Engineer-in-Charge; or
- ii) fails to complete the work (s) or any item of work (s) within the time or any extended time under the contract and does not complete the work (s) or any item of works within the period specified in a notice given in writing in that behalf by the Engineer-in-Charge ; or
- iii) assigns, transfers, sublets (engagement of labour on a piece-work basis or of labour with materials not being incorporated in the work shall not be deemed to be subletting) or attempts to assign, transfer or sublet the entire works or any portion thereof without the prior written approval of the Engineer-in-Charge. The Engineer-in-Charge shall have powers to terminate the contract in full or in part as aforesaid without prejudice to any other right or remedy which shall have accrued or shall accrue of which cancellation notice in writing to the Contractor under the hand of the Engineer-in-Charge shall be conclusive evidence.

33.2 Corrupt Practice

The Contractor shall not offer or to give to any person in the employment of the Authority or working under the orders of the Chairman any gift or consideration of any kind as an inducement or reward for doing or forbearing to do or for having done or forborne to do any act in relation to the obtaining or execution of the contract or any other contract with the purchaser or for showing or forbearing to show favour or disfavour to any person in relation to the contract or any other contract with the purchaser. Any breach of the aforesaid condition by the contract, or any one employed, by him or acting on his behalf (whether with or without the knowledge of the Contractor) or the commission of any offence by the Contractor or by any one employed by him or acting on his behalf under Chapter IX of the Indian Penal Code 1860 or the Prevention of Corruption Act. 1947 or any other Act enacted for the prevention of corruption by Public Servant shall entitle the Chairman to cancel the contract and all or any other contracts with the Contractor and to recover from the Contractor the amount of any loss arising from such cancellation in accordance with the provisions of General condition and Special conditions.

33.3 The Engineer-in-Charge shall, on such termination of the contract, have powers

- i) To take possession of the site of work under the contract as well as the land / premises allotted to the contractor for his preliminary, Enabling and Ancillary works and
- ii) Also any materials, constructional plant, equipment, implements, stores, structures etc. thereon. The Engineer-in-Charge shall also have powers to carry out the incomplete work by any means or through any other agency or by himself at the risk and cost of the contractor. In such agencies shall be credited to the contractor at his contract prices and the contractor shall pay the excess amount, if any, incurred in completing the work as aforesaid, as stipulated under sub-clause 33.5 hereunder.

- 33.4 On termination of the contract in full or part, the Engineer-in-Charge may direct that a part or whole of such plant, equipment and materials, structures be removed from the site of the work as well as from the land/premises allotted to the contractor for his preliminary, enabling and ancillary works, within a stipulated period if the contractor shall fail to do so within the period specified in a notice in writing by the Engineer-in-Charge, the Engineer-in-Charge may cause then to be sold, holding the net proceeds of such sale to the credit of the contractor, which shall be released after completion of works and settlement of amounts under the contract.
- 33.5 If the expenses incurred or to be incurred by the Authority for carrying out and completing the incomplete work or part of the same, as certified by the Engineer-in-Charge, are in excess of the value of the work credited / to be credited to the contractor, the difference shall be paid by the contractor to the Authority. If the contractor fails to pay such an amount, as aforesaid, within thirty days of receipt of notice in writing from the Engineer-in-Charge, the Engineer-in-Charge shall be empowered to recover such amount from any sum due to the contractor on any account under this or any other contract or from his security deposit or otherwise.
- 33.6 Also, the Engineer-in-Charge shall have the right to sell any or all of the contractor's unused materials, constructional plant, equipment, implements, temporary building / structures etc. and apply the proceeds of sale thereof towards the satisfaction of any sums due from the contractor under the contract and if thereafter there may be any balance outstanding from the contractor, the Engineer-in-Charge shall have powers to recover the same in accordance with the provisions of the contract.
- 33.7 The contractor shall not construct any structure even of a temporary nature for any other purpose on IWAI office premises & Engineer-in-Charge's representative's office or houseboat, or any such things except with the written permission of the EIC and any such construction, so put up shall be removed by the contractor whenever the EIC or his representative calls upon the contractor to remove. Any dispute or difference in respect of either the interpretation effect or application of the above conditions or of the amount recoverable there under by the purchaser from the Contractor, shall be decided by the Chairman.

CLAUSE - 34: COMPLETION TIME AND EXTENSIONS

34.1 The Engineer-in-Charge will make available to the contractor the site to enable the contractor to commence & proceed with the execution of the work in accordance with agreed programme. If there is any delay in making available any area of the work or the delays mentioned in Para 34.4, the competent authority as specified in schedule 'B' on the recommendations of the Engineer-in-Charge shall grant reasonable extension of time for completion of work. However, in case of the contracts having tendered value up to Rs. 500 lakhs, if the total extension involved due to delay is up to 1/3rd of the stipulated period of completion then the Engineer-in-Charge shall decide the extension and convey the same to the contractor. But the contractor shall not claim any compensation whatsoever on this account.

34.2 If after the award of the work the contractor commits defaults in commencing the execution of work as aforesaid, Govt. shall without prejudice to any other right or remedy available in law, be at liberty to forfeit the earnest money & performance guarantee absolutely.

34.3 As soon as possible after the Contract is concluded, the Contractor shall submit a Time and Progress Chart get it approved by the Department. The Chart shall be prepared in direct relation to the time stated in the Contract documents for completion of items of the works. It shall indicate the forecast of the dates of commencement and completion of various trades of sections of the work.

34.4 However, if the work (s) be delayed by:-

- (i) Force majeure as per clause 27, or
- (ii) Abnormally bad weather, or
- (iii) Serious loss or damage by fire, or
- (iv) Civil commotion, local commotion of workmen, strike or lockout, affecting any of the trades employed on the work, or
- (v) Delay on the part of other contractors or tradesman engaged by Engineer-in-Charge in executing work not forming part of the contract, or
- (vi) Non-availability of stores, which are the responsibility of Government to supply or
- (vii) Non-availability of breakdown of Tools and Plant to be supplied or supplied by Government or
- (viii) Any other cause which, in the absolute discretion of the Engineer-in-Charge is beyond the Contractor's control.

then immediately upon the happening of any such events as aforesaid, the contractor shall inform the Engineer-in-Charge accordingly, but the contractor shall nevertheless use constantly his best endeavors to prevent and/or make good the delay and shall do all that may be required in this regard. The Contractor shall also request, in writing, for extension of time, to which he may consider himself eligible under the contract, within fourteen days of the date of happening of any such events as indicated above.

34.5 In case the cost of the work is more than 10 crores than the total scope of work will be divided into milestones. The contractor shall submit a Time & Progress chart for each milestone and get it approved by the competent authority.

34.6 Request for rescheduling of Mile stones and extension of time, to be eligible for consideration, shall be made by the Contractor in writing within fourteen days of the happening of the event causing delay on the prescribed form to the competent authority as indicated in Schedule 'B'. The Contractor may also, if practicable, indicate in such a request the period for which extension is desired.

34.7 In any such case as may have arisen due to any of the events, as aforesaid, and which may have been brought out by the contractor in writing, the Competent Authority mentioned in Scheduled 'B' may give a fair and reasonable extension of time, after taking into consideration the nature of the work delayed and practicability of its execution during the period of extension.

34.8 Such extensions shall be communicated to the contractor by the Engineer-in-Charge in writing. The contractor shall not be entitled to claim any compensation or over run charges whatsoever for any extension granted.

CLAUSE – 35 : COMPENSATION FOR DELAY

35.1 If the contractor fails to complete all items of works in respect of any of the sub-group/group and/or work as a whole as the case may be and before the expiry of the

period(s) of completion as stipulated in the aforesaid tender or any extended period (not due to the fault of the contractor) as may be allowed, he shall without prejudice to any other right or remedy of the Authority on account of such default, pay as an ascertained/agreed compensation as per Clause No. 36.

CLAUSE – 36 : LIQUIDATED DAMAGES

If the contractor fails to maintain the required progress in terms of clause 34 or to complete the work and clear the site on or before the date of completion as per the contract or extended date of completion, he shall, without prejudice to any other right or remedy available under the law to the authority on account of such breach, pay as agreed liquidated damages the amount calculated at the rates stipulated below.

(i) Liquidated Damages @ 1.5 % per month of delay for delay of work to be computed on per day basis provided always that the total amount of compensation for delay to be paid under this condition shall not exceed 10% of the Tended Value of work. The competent authority mentioned in Schedule “B” (whose decision in writing shall be final & binding) may decide on the amount of tendered value of the work for every completed day/month (as applicable) that the progress remains below that specified in Clause 34 or that the work remains incomplete. The amount of liquidated damages may be adjusted or set-off against any sum payable to the Contractor under this or any other contract with the authority.

In case of contracts having tendered amount more than 10 crores, if the contractor does not achieve a particular milestone mentioned in schedule „B”, or the re- scheduled milestone(s) in terms of Clause 34.6, the amount shown against that milestone shall be withheld, to be adjusted against the liquidated damages levied at the final decision on Extension of Time. With-holding of this amount on failure to achieve a milestone, shall be automatic without any notice to the contractor. However, if the contractor catches up with the progress of work on the subsequent milestone(s), the withheld amount shall be released. In case the contractor fails to make up for the delay in subsequent milestone(s), amount mentioned against each milestone missed subsequently also shall be withheld. However, no interest, whatsoever, shall be payable on such withheld amount.

In case of contracts having tendered amount less than 10 crores, if the work remains incomplete after the stipulated date of completion, the Engineer-in-charge may withhold 10% of the tendered value of the work from the running payments of the contractor pending final decision of the competent authority mentioned in schedule “B” on the extension of time case. If the competent authority decides to grant extension of time without levy of liquidated damages or levy part of the total liquidated damages specified above then the balance withheld amount after adjusting the amount of the liquidated damages levied by the competent authority will be refunded to the contractor.

CLAUSE – 37 : INSPECTION AND APPROVAL

- 37.1 All works involving more than one process shall be subject to examination and approval at each stage thereof and the contractor shall give due notice to the Engineer-in-Charge on his authorized representative, when each stage is ready. In default of such notice, the Engineer-in-Charge shall be entitled to appraise the quality and extent thereof and the decision of the Engineer-in-Charge in this regard shall be final and binding.
- 37.2 No work shall be put out of view without the approval of the Engineer-in-Charge or his authorized representative and the Contractor shall afford full opportunity for examination.

The contractor shall give due notice to the Engineer-in-Charge or his authorized representative whenever any such work is ready for examination and the Engineer-in-Charge or his representative shall, without unreasonable delay, unless he consider it necessary and advise the contractor accordingly, examine and measure such work. In the event of the failure or the contractor to give such notice, he shall if required by the Engineer-in-Charge, uncover such work at the contractor's expenses.

- 37.3 Periodic inspection will be carried out by the EIC or his representative by their vessels. The contractor can have the inspection schedules finalized with the Engineer-in-charge. Generally all attempts should be made to have joint inspection and number of inspections be not less than three in a calendar month.

CLAUSE – 38 : COMPLETION CERTIFICATE

- 38.1 The work shall be completed to the entire satisfaction of the Engineer-in-Charge and with in the specified time limit and terms and conditions of the contract. As soon as the work under the contractor is completed as a whole the contractor shall give notice of such completion to the Engineer-in-Charge. The Engineer-in-Charge shall inspect the work and shall satisfy himself that the work(s) has been completed in accordance with the provisions of the contract and then issue to the Contractor a certificate of completion indicating the date of completion. Should the Engineer-in-Charge notice that there are defects in the works or the works are not considered to be complete, he shall issue a notice in writing to the Contractor to rectify / replace the defective work or any part thereof or complete the work, as the case may be within such time as may be notified and after the contractor has complied with as aforesaid and gives notice of completion the Engineer-in-Charge shall inspect the work and issue the completion certificate in the same manner as aforesaid.
- 38.2 No certificate of completion shall be issued as stipulated above and no work be considered to be completed unless the contractor shall have removed from the work site and / or premises all his belongings / temporary arrangements brought / made by him for the site and / or premises in all respects and made the whole of the site and / or premises fit for immediate occupation / use to the satisfaction of the Engineer-in-Charge. If the contractor fails to comply with the above mentioned requirements on or before the date of completion of the work, the Engineer-in-Charge, may as he thinks fit and at the risk at cost of the contractor, fulfill such requirements and remove / dispose of the contractor's belongings / temporary arrangements, as aforesaid, and the contractor shall have no claim in this respect except for any sum realised by the sale of Contractor's belongings / temporary arrangements less the cost of fulfilling the said requirements and any other amount that may be due from the contractor. Should the expenditure on the aforesaid account exceed the amount realised by sale of such contractor's belongings / temporary arrangements then the contractor shall on demand pay the amount of such excess expenditure.

CLAUSE - 39 : MEASUREMENTS

- 39.1 The Engineer-in-charge shall expect as otherwise stated ascertain and determine by measurement the value of work done in accordance with the contract.
- 39.2 Notwithstanding any provision in the relevant standard method of measurement or any general or local custom, measurement of work done under the contract shall be taken in accordance with the procedure set forth in the Technical Specifications or Schedule of Quantities under the contract. In case of items of work which are not covered by the

Technical Specifications or Schedule of Quantities measurement shall be taken in accordance with the relevant standard methods of measurement laid down by the Bureau of Indian Standard.

- 39.3 All items having a financial value shall be entered in daily log book/ measurement book prescribed by the Authority so that the complete work performed under the contract is duly accounted.
- 39.4 Measurement shall be taken jointly by the Engineer-in-Charge or his authorized representative and by the contractor or his authorized representative.
- 39.5 Before taking measurements of any works, the Engineer-in-Charge or representative deputed by him for the purpose, shall give a reasonable notice to the Contractor. If the Contractor fails to attend or send an authorized representative for measurement after such notice or fails to countersign or to record the objection within a week from the date of taking the measurements, taken by the Engineer-in-Charge shall be taken to be correct and final measurements of such works.
- 39.6 The contractor shall, without extra charge, provide assistance with every appliance, labour and other things necessary for measurement.
- 39.7 Measurements shall be signed and dated by both parties each day on the Site on completion of measurement. If the contractor objects to any of the measurement recorded by the representative of the Engineer-in-Charge a note to the effect shall be made in the item objected to and such note shall be signed and dated by both parties engaged in taking the measurement. The decision of the Engineer-in-Charge on any such dispute or difference or interpretation shall be final and binding on the contractor in respect of all contract items, substituted items, extra items and deviations.

CLAUSE – 40: PAYMENT ON ACCOUNT

- 40.1 Interim bills shall be submitted by the contractor monthly on or before 5th of every month or the date fixed by the Engineer-in-Charge for the items of work completed. The Engineer-in-Charge shall then arrange to have the bills verified with reference to the measurements recorded in the measurement book(s).
- 40.2 Payment on account for amount admissible shall be made by the Engineer-in-Charge certifying the sum to which the contractor is considered entitled by way of interim payment for the work executed, after deducting there from the amount already paid, the security deposit and such other amounts as may be withheld, deductible or recoverable in terms of the contract.
- 40.3 Payment of the contractor's bills shall be made by the Authority only in Indian Rupees within 30 days from the date of submission of the bill subject to the acceptance of the Engineer-in-Charge.
- 40.4 Payments due to the contractor shall be made by e- mode by the Engineer-in-Charge or his authorized representative.

- 40.5 Any interim certificate given relating to work done or materials delivered may be modified or corrected by any subsequent interim certificate or by the final certificate. No certificate(s) of the Engineer-in- Charge supporting an interim payment shall itself be conclusive evidence that any work or materials to which it relates is / are in accordance with the same.
- 40.6 Should there be a request for extension of date of completion, pending its consideration interim payments shall continue to be made as provided herein.
- 40.7 TDS at the applicable rates shall be deducted at source from any payment made to the contractor against this contract.

CLAUSE – 41 : TAXES, DUTIES AND LEVIES ETC.

- 41.1 The prices shall include all the taxes, levies, cess, octroi, royalty, terminal tax or any other local or central taxes as applicable/ charged by Center or State Government or Local authorities except GST on all materials, including steel, wood, POL (and increase if any, on these during the currency of the contract) that the contractor has to purchase for the performance of the contract, shall be payable by the contractor and the Authority will not entertain any claim for compensation whatsoever in this regard. The rates quoted by the contractor shall be deemed to be inclusive of all such taxes, duties, levies, etc except GST.

CLAUSE - 42 : TAX DEDUCTION AT SOURCE

- 42.1 TDS at the applicable rate as per Income Tax Act/ Rules shall be deducted from all the payment/ advances made against the contract.

CLAUSE – 43 : PAYMENT OF FINAL BILL

The final bill shall be submitted by the contractor within one month from the date of completion of the work or of the date the certificate of completion furnished by the Engineer-in-Charge. No further claim in this regard unless as specified herein under shall be entertained. Payment shall be made within three months. If there shall be any dispute about any item or items of the work then the undisputed item or items only shall be paid within the said period of three months or six months, as the case may be. The contractor shall submit a list of the disputed items within thirty days from the disallowance thereof and if he fails to do so, his claim shall be deemed to have been fully waived and absolutely extinguished.

CLAUSE - 44: OVER PAYMENTS AND UNDER PAYMENTS

- 44.1 Whenever any claim whatsoever for the payments of a sum of money to the Authority arises out of or under this contract against the contractor, the same may be deducted by the Authority from any sum then due or which at anytime thereafter may become due to the contractor under this contract and failing that under any other contract with the Authority or from any other sum whatsoever due to the contractor from the Authority or from the Authority or from his security deposit, or he shall pay the claim on demand.
- 44.2 The Authority reserves the right to carry out post- payment audit and technical examination of the final bill including all supporting vouchers, abstracts, etc. The authority further reserves the right to enforce recovery of any over payment when detected not- withstanding

the fact that the amount of the final bill may be included by one of the parties as an item of dispute before an arbitrator appointed under clause 48 of this contract and notwithstanding the fact that the amount of the final bill figures in the arbitration award.

- 44.3 If as a result of such audit and technical examination any over payment is discovered in respect of any work done by the contractor or alleged to have been done by him under contract, it shall be recovered by the Authority from the contractor by any of all of the methods prescribed above, and if any under payment is discovered, the amount shall be duly paid to the contractor by the Authority.
- 44.4 Provided that the aforesaid right of the Authority to adjust over-payment against amount due to the contractor under any other contract with the Authority shall not extend beyond the period of two years from the date of payment of the final bill or in case the final bill is a MINUS bill, from the date the amount payable by the Contractor under the MINUS final bill is communicated to the contractor.
- 44.5 Any sum of money due and payable to the Contractor (including the security deposit returnable to him) under the contract may be withheld or retained by way of lien by the Engineer-in-Charge or Authority against any claim of the Authority or such other person or persons in respect of payment of a sum of money arising out of or under any other contract made by the contractor with the Engineer-in-Charge or Authority or with such other person or persons. The sum of money so withheld or retained under this clause by the Engineer-in-Charge or Authority will be kept withheld or retained as such by the Engineer-in-Charge or Authority or till his claim arising out of in the same contract or any other contract is either mutually settled or determined by the arbitrator, if the contract is governed by the arbitration clause under the clause 48 or by the competent court hereinafter provided, as the case may be, and the contractor shall have no claim for interest or damages whatsoever on this account or any other ground in respect of any sum of money withheld or retained under this clause.

CLAUSE - 45 : CONTRACT MATTERS TO BE TREATED AS CONFIDENTIAL

- 45.1 All documents, correspondence, decisions and orders concerning the contract shall be considered as confidential and/or restricted in nature by the contractor and he shall not divulge or allow access to them by any un-authorized person.
- 45.2 The contractor shall take necessary steps to ensure that all persons employed on any work in connection with this contract have noted that the Indian Official Secrets Act, 1923 (XIX of 1923) applies to them and shall continue so to apply even after the execution of such under the contract.

CLAUSE – 46 : FINALITY CLAUSE

It shall be accepted as an inseparable part of the contract that in matters regarding materials, workmanship, removal of improper work, interpretation of the contract drawings and contract specifications, mode of procedure and the carryout out of the work the decision of the Engineer-in-Charge which shall be given in writing shall be final and binding on the contractor.

CLAUSE – 47 : SUM PAYABLE BY WAY OF COMPENSATION TO BE CONSIDERED IS REASONABLE WITHOUT PREFERENCE TO ACTUAL LOSS

All sum payable by way of compensation to the Authority under any of these conditions shall be considered as reasonable compensation without reference to the actual loss or damage sustained and whether or not damage shall have been sustained.

CLAUSE – 48: ARBITRATION

- 48.1 Except as otherwise provided herein before, all questions, disputes or difference in respect of which the decision has not been final and conclusive arising between the Contractor and the Authority in relating to or in connection with contract shall be referred for arbitration in the manner provided as under and to the sole arbitrator appointed as follows:
- (i) Either of the parties may give to the other notices in writing of the existence of such question dispute or difference.
 - (ii) Within thirty (30) days of receipt of such notice from either party the engineer-in-charge of work at the time of such dispute shall send to the Contractor panel of three persons and there after the Contractor within fifteen (15) days of receipt of such panel communicate to the Engineer-in-charge the name of one of the persons from such panel and such a person shall then be appointed as sole arbitrator by the Chairman, IWAI. However, the arbitration so appointed shall not be an officer or the employee of Inland Waterways Authority of India.
 - (iii) Provided that if the Contractor fails to communicate the selection of a name out of the panel so forwarded to him by the Engineer-in-charge then after the expiry of the aforesaid stipulated period the Chairman, shall without delay select one person from the aforesaid panel and appoint him as the sole arbitrator.
- 48.2 The arbitrator to whom the matter is originally referred being transferred or vacating his office or being unable to act for any reason, then the Director (I/C) shall appoint another person to act as sole arbitrator, such person shall be entitled to proceed with the reference from the stage at which it was left by the predecessor.
- 48.3 The award of the Arbitrator shall be final and binding. The Arbitrator shall decide in what proportion the Arbitrator's fees, as well as the cost of Arbitration proceeding shall be borne by either party.
- 48.4 The Arbitrator with the consent of the parties can enlarge the time, from, time-to-time to make and publish his award.
- 48.5 A notice of the existence in question, dispute or difference in connection with the contract unless served by either party within 30 days of the expiry of the defects liability period, failing which all rights and claim under this contract shall be deemed to have been waived and thus forfeited and absolutely barred.

- 48.6 The Arbitrator shall give reasons for the award if the amount of claim in dispute is Rs. 75000/- and above.
- 48.7 The work under this Contract shall continue during Arbitration proceedings and no payments due from or payment by the Authority shall be withheld on account of such proceedings except to the extent which may be in dispute.
- 48.8 The Arbitration and Conciliation Act 1996 with any statutory modifications or re-enactment thereof and the rules made there under and being in force shall apply to the Arbitration proceedings under this clause.

NOTE: In case of contract with another Public Sector Undertaking, following Arbitration Clause shall apply: "Except as otherwise provided, in case of a contract with a public Sector Undertaking if at any time any question dispute or difference whatsoever arises between the parties upon or in relation to, or in connection with this agreement, the same shall be settled in terms of the Ministry of Industry, Department of Public Enterprises O.M No. 3/5/93-PMA dt.30.06.93 or any modifications / amendments thereof. "The arbitrator shall have the power to enlarge the term to rate the award with the consent of the parties provided always that the commencement or continuation of the arbitration proceeding shall not result in cessation or suspension of any of other rights and obligations of the parties of any payments due to them hereunder.

- 48.9 The parties to the agreement hereby undertake to have recourse only to arbitration proceedings under for Arbitration Act 1996 and the venue of the arbitration proceeding shall be Noida/ New Delhi and the parties will not have recourse to Civil Court to settle any of their disputes arising out of this agreement except through arbitration.

PART- III

TECHNICAL SPECIFICATIONS & SPECIAL CONDITIONS, SPECIAL TERMS & CONDITIONS

1. INTRODUCTION

Inland Waterways Authority of India (IWAI) is a statutory body set up in 1986 under the Ministry of Surface Transport, Govt. of India. The Authority is entrusted with development, maintenance and management of National Waterways for shipping and navigation.

It is proposed to undertake the development works for IWAI through an agency appointed on open tender basis. The detailed specifications and other technical conditions have been placed in detail in the schedule / Bill of quantity. Further, it is to be noted that if any specification is not clear for any work fall on this project, then the CPWD specification shall be followed by both the bidder and IWAI. The technical condition and details are given below:

CONDITIONS OF CONTRACT

1. **Name of work:** G.I barbed wire with RCC post (5line Horizontal) fencing and Jungle clearance at land of extension of Multi Modal Terminal, Ramnagar, Varanasi.
2. **Time Period:** G.I barbed wire with RCC post (5line Horizontal) fencing and Jungle clearance at land of extension of Multi Modal Terminal, Ramnagar, Varanasi **within 60 days after issuing of the work order.**
3. **Pricing Basis:** All units rates mentioned under the work order shall be firm and subject to no variation through the duration of work order, duties, coats and any other charges.
4. **Terms of Payment:**
 - i. The R.A bill & final bill shall be examined and paid within 30 days of completion of the work and after issuance of work done certificate by the E-I-C.
 - ii. Tax at sources and other deduction will be deducted from the contractor's payment as per the applicable rates.
5. **Period of Maintenance:** The "Period of Maintenance" for the work is 1(One) year from the date of taking over possession. During the period of maintenance, the contractor will be responsible for rectifying any defects in construction free of cost to the Employer.
6. **Other Conditions:**
 - i. No idle time charges will be paid to the contractor on any account.
 - ii. The Engineer in charge or his respective will inspect, co-ordinate, measure and certify the supply work.
 - iii. The contractor may execute the work round clock and on all days including Sunday and public holidays with due permissions of the E.I.C in written except National Holidays and subject to such restriction as may be imposed by State Govt./Local Body.

- iv. The right to award split up work or to reject the offer without assigning any reason is reserved with the Authority.
- v. The contractor will submit to the Authority by bill in duplicate after completion of the erection of GI barbed wire fencing and jungle clearance as per specific, terms and conditions of the contract.
- vi. The rate quoted shall include all taxes, duties and any other levies. No additional payment on any such account shall be payable by IWAI. However, on request IWAI may extend the assistance for solving the issues only through the concerned official/dept. of the state or local bodies.
- vii. During execution of the work, if any enforcing accident occurs, the same shall be rectified/Handle by the contractor at his cost, without claiming additional payment from IWAI.

CIVIL WORK

- i) Coarse aggregate shall be of hard broken stone of granite or similar stone, free from dust, dirt and other foreign matters. The stone blast shall be of 20 mm (3/4") size and down and all should be retained in a 5 mm square mesh (1/4") and well graded such that the voids do not exceed 42percent.
- ii) Sand shall be of standard specifications clean and free from dust, dirt and organic matters. Sea sand shall not be used. Sand to be used for cement concrete work, mortar for masonry and plaster work shall be of standard quality. Sand to be got approved from the Engineer-in-charge and screened as required.
- iii) Cement shall be fresh Portland cement of standard I.S.I. specifications, and shall have the required tensile and compressive stresses and fineness.
- iv) Steel reinforcing bars shall be of mild steel or deformed steel of standard specifications and shall be free from corrosion, loose rust scales, oil, grease, paint etc. The steel bar shall be round and capable of being bent (doubled over) without fracture.
- v) G.I. barbed wire : The barbed wire shall be of galvanized steel as specified and it shall conform to IS 278. The wire shall be manufactured from steel by any process and shall not contain sulphur and phosphorous exceeding 0.065 per cent.
- vi) RCC Post: All posts and struts shall be of standard size, the length of posts being 2.1 m. These shall be cast in cement concrete 1:1 ½ :3 (1 cement : 1 ½ coarse sand : 3 graded stone aggregate 12.5 mm nominal size) reinforced with 8 mm diameter tor steel bars as directed and finished smooth with cement mortar 1:2 (1 cement: 2 fine sand). The specifications for R.C.C. work shall apply. The posts shall be free from cracks, twists and such other defects. G.I. staples on wooden plugs or 6 mm bar nibs will be provided as directed by Engineer-in-Charge while casting the posts. Quantity of RCC post, struts, Rails and Pales to be measured in cubic content.
- vii) Spacing of Posts: The spacing between posts shall be three metres centre to centre or as directed by the Engineer -in-Charge to suit the dimensions of the area to be fenced.

- viii) **Fixing of Posts:** Pits 30 x 30 cm and 50 cm deep or as directed shall first be excavated true to line and level to receive the posts. The pits shall be filled with a layer of cement concrete 1:3:6 (1 cement: 3 fine sand: 6 graded stone aggregate 40 nominal size). The posts and struts shall then be placed in the pits, the posts projecting 1.6 m height above ground, true to line and position. The concrete in foundations shall be watered for at least 7 days to ensure proper curing. The remaining portions of pits shall be filled up with excavated earth and the surplus earth disposed off as directed by the Engineer-in-charge and site cleared.
 - ix) **Fixing G.I. Barbed Wire:** The barbed wire (12.5mm gauge, spacing of points – 4 inches) shall be stretched and fixed in five number of rows. The bottom row shall be 10 cm above ground and the rest at 35 cm centre to centre. The barbed wire shall be held to the R.C.C. posts by means of G.I. staples fixed to wooden plugs or G.I. binding wire tied to 6 mm bar nibs fixed while casting the posts.
 - x) **Hydraulic Excavator:** The Hydraulic excavator deployed for cleaning the jungle shall comprise uprooting of rank vegetation, grass, brushwood, shrubs, stumps, trees and saplings of girth upto 30 cm measured at a height of one metre above the ground level and removal of rubbish up to a distance of 50 m outside the periphery of the area cleared.
The Hydraulic Excavator should be unique capability to excavate, load, haul and dump materials.
- e) **Materials:** All the Materials what are used by the contractor that must be ISI marks or reputed/approve brand.

SPECIAL CONDITIONS

A. HOLD HARMLESS:

- i) The Contractor should indemnify and hold the Authority harmless from any liability or claim for damages because of bodily injury, death, property damage, sickness, disease or loss and expense arising from the Contractor's performance of this Contract.
- ii) The Contractor is acting in the capacity of an independent contractor with respect to the Authority.
- iii) The Contractor should protect, defend and indemnify the Owner from any claims by labourers or Sub Contractors for unpaid work or labour performed in connection with this Contractor.

B. CHANGE ORDERS:

- i) The Contractor should not make any changes in the schedule of work or the Specifications without written authorization by the Engineer in Charge and written concurrence by the Authority.

C. UNSATISFACTORY PERFORMANCE:

- i) In case of unsatisfactory performance/ progress / services by the Contractor, IWAI shall have the right to issue a show cause notice to the consultant requiring him to explain the reason thereof.
- ii) In case of continuation of such unsatisfactory performance / progress / services, IWAI reserves the right to rescind the Contract and get the balance work executed at the risk and cost of the Contractor.

D. WARRANTIES:

- i) The Contractor should warrant that this contract does not and shall not infringe any existing or subsequent patents, rights or licenses of any third party.
- ii) The Contractor should further warrant that the rights of the Authority under the present contract are not and shall not be infringed by any prior or subsequent contract, which may have been or may hereafter be entered into by the Contractor with any other party.

E. MISCELLANEOUS:

- i) The Contract embodies the entire understanding of the parties as to its subject matter and shall not be amended except in writing executed by both the parties and subject to the approval of the concerned authorities.

.....

PART-IV

SCHEDULE OF QUANTITIES

BOQ

G.I BARBED WIRE WITH RCC POST (5LINE HORIZONTAL) FENCING AND JUNGLE CLEARANCE AT LAND OF EXTENSION OF MULTI MODAL TERMINAL, RAMNAGAR, VARANASI.

| Sl. No | Description of Item | Units | Qty | Rate [(Including all taxes and GST 12%) (in Rs)] | Amount (in Rs) |
|----------|---|-------|-------|--|----------------|
| A | BARBED WIRE FENCING | | | | |
| 1 | Excavation of soil including all machineries, labour etc. Complete all or as directed by Engineer-In-Charge. | Cum | 16.20 | | |
| 2 | Supply and fixing of R.C.C. Standards post/struts/rails/pales of mix 1:1.5:3 (1 cement: 1.5 coarse sand: 3 graded stone aggregate 12.5 mm nominal size) with wooden plugs or 6mm bar nibs wherever required as per drawings and direction of Engineer-In-Charge. | Cum | 17.28 | | |
| 3 | Charges of concreting work for PCC including all labour, materials, machineries, curing, finishing, removal of debris and disposal, general housekeeping etc. Complete all or as directed by Engineer-In-Charge. | Cum | 14.40 | | |
| 4 | Supply and fixing of barbed wire complete all or as directed by Engineer-In-Charge. | Rmt | 4500 | | |
| B | JUNGLE CLEARANCE | | | | |
| | Clearing jungle including uprooting of rank vegetation, grass, brush wood, trees and saplings of girth up to 30 cm measured at a height of 1 m above ground level and removal of rubbish up to a distance of 50 m outside the periphery of the area cleared. By means of Hydraulic Excavator. | Sqm | 7500 | | |
| | | | | Total (Inc. 12% GST) | |

Note :-

If the quoted rate for the individual item of the BOQ are abnormally high or low against the estimated rate (supported with schedule of rate.) IWAI have the right to disqualify the bidder. In this regard, prevailing guidelines of CPWD manual will be referred & Violation of any clause will lead to disqualification of the bidder

(Signature of the Bidder, with official Seal)

AGREEMENT FORMAT

This agreement made on _____ day _____ year _____ between the Inland Waterways Authority of India (hereinafter called the 'IWAI' which expression shall unless excluded by or repugnant, to the context, be deemed to include heir, successors in office) on one part and M/S _____ (hereinafter called the "CONTRACTOR" which expression, shall unless excluded by repugnant to the context be deemed to include his heirs, executors, Administrators, representatives and assigns of successors in office) on the other part.

WHEREAS THE IWAI desirous of undertaking the works for

WHEREAS the contractor has offered to execute and complete such works and whereas IWAI has accepted the tender of the contractor and WHEREAS the contractor has furnished

as security for the due fulfillment for all the conditions of this contract.

NOW IN THIS AGREEMENT WITNESSTH AS FOLLOWS

In this agreement words and expression shall have the same meaning as are respectively as assigned to them in the conditions of contract hereinafter referred to:

The following documents shall be deemed to form and be read and construed as part of this agreement VIZ.

- i) (a) Notice Inviting Tenders
 - (b) Tender form
 - (c) Warranty
- ii) Information & instruction for Tenders
- iii) (a) Schedule : Bill of Quantity
 - (b) Annexure
- iv) General Conditions of Contract
- v) Technical specifications and Special Conditions of Contract

The contract agreement has been compiled by the IWAI from the original tender documents and all the correspondences from the tendering stage till acceptance. In the event of any difference arising from the completion of the contract, the original tender documents, contractor's offer, minutes of meetings and correspondence between the party ended vide letter No. _____ may be referred to by either party. These documents shall take precedence over the compiled documents.

The contractor hereby covenants with the IWAI to complete and maintain the “Works” in conformity in all respect, with the provisions of the agreement.

The IWAI hereby covenants to pay the contractor in consideration of such completion of works, the contract price at the time and in the manner prescribed by the contract.

IN WITNESS WHEREOF the parties hereunto have set their hands and seals on the day year first written

For and on behalf of

For and on behalf of

(Inland Waterways Authority of India)

Contractor

Signature _____

Signature _____

Name & Designation _____

Name & Designation _____

Stamp

Stamp

Witness:

Witness:

1) Signature _____

1) Signature _____

2) Name & Designation _____

2) Name & Designation _____

**BANK GUARANTEE PROFORMA FOR FURNISHING
PERFORMANCE GUARANTEE**

**To
The Chairman
Inland Waterways Authority of India
A-13, Sector-1
Noida - 201301**

In consideration for the Chairman, Inland Waterways Authority of India hereinafter called „the Authority” having agreed, under the terms and conditions of the Agreement dated made between..... and ...for the due fulfillment of the said Agreement by the Contractor of the terms and conditions contained in the said Agreement, on production of Bank Guarantee for Rs..... (Rupees.....) at the request of..... Contractor(s), We (Bank) do hereby undertake to pay to the Authority an amount not exceeding Rs..... against any loss or damage caused to or suffered, or would be caused to or suffered by the Authority by reason of any breach of the said Contractor(s) of any of the terms or conditions contained in the said Agreement.

2. We..... do hereby undertake to pay the amount due and payable under this Guarantee without any demur, merely on a demand from the Authority stating that the amount claimed is due by way of loss or damage caused to or would be caused to or suffered by the authority by reason of breach by the said contractor(s) of any of the terms or conditions contained in the said Agreement or by reason of the contractor(s)’s failure to perform the said Agreement,. Any such demand made on the Bank shall be conclusive as regards the amount due and payable by the Bank under this guarantee. However, our liability under this guarantee shall be restricted to an amount not exceeding Rs.....

3. We undertake to pay the authority any money so demanded notwithstanding any dispute or disputes raised by the contractor(s) / suppliers(s) in any suit or proceeding pending before any court or Tribunal relating thereto liability under this present being absolute and unequivocal.

The payment so made by us under this Bond shall be valid discharge of our liability for payment there under and the contractor(s) / supplier(s) shall have no claim against us for making such payment.

4. We, further agree that the guarantee herein contained shall remain in full force and effect during the period that would be taken for the performance of the said Agreement and that it shall continue to be enforceable till all the dues of the Authority under or by virtue of the said Agreement have been fully and its claim satisfied or discharge or till..... Certify that the terms and conditions of the said Agreement have been fully and properly carried out by the said Contactor(s) and accordingly discharges this Guarantee after..... years from the date of completion of the said contract unless a demand or claim under this Guarantee is served in writing on the bank but before the expiry of the said period of years in which case it shall be enforceable against the bank not withstanding the fact that the same is enforced after the expiry of the said period of years.

5. We,.....further agree with the Authority that the Authority shall have the fullest liberty without our consent and without affecting in any manner our obligations hereunder to vary any of the terms and conditions of the said Agreement or to extend time of performance by the said Contractor(s) from time to time or to postpone for any time or from time to time any of the powers exercisable by the Authority against the said Contractor(s) and to forbear or enforce any of the terms and conditions relating to the said Agreement and we shall not be relieved from our liability by reason of any such variation, or extension being granted to the said Contractor(s) or for any forbearance, act or omission on the part of the Authority or any indulgence by the Authority to the said Contractor(s) or by any such matter or thing whatsoever which under the law relating to sureties would, but for the provision, have effect of so relieving us.

6. It shall not be necessary for the Authority to proceed against the Contractor before proceeding against the Bank and the Guarantee herein contained shall be enforceable against the Bank notwithstanding any security which the Authority may have obtained or obtain from the Contractor shall at the time when proceedings are taken against the Bank hereunder be outstanding or unrealized.

7. Notwithstanding anything contained herein above our liability under the guarantee is restricted to Rs..... and shall remain in force until..... Unless a claim or suit under this guarantee is filed with us on or before..... ALL OUR RIGHTS UNDER THE GUARANTEE SHALL BE FORFEITED, and the bank shall be relieved and discharged from all liabilities therein.

8. This Guarantee will not be discharged due to the change in the constitution of the Bank or the Contractor(s) / supplier(s).

9. We,..... lastly undertake not to revoke this Guarantee during its currency except with the previous consent of the Authority in writing.

Dated thedate of.....2010
for.....
(indicate the name of Bank)
Signature.....
Name of the Officer.....
(in Block Capitals)
Designation of
Code No.....
Name of the Bank and Branch.

**DETAILS OF BANK ACCOUNT FOR RELEASE OF PAYMENT
THROUGH ELECTRONIC FUND TRANSFER SYSTEM**

(TO BE FURNISHED BY THE BIDDER ON IT'S LETTER HEAD)

NAME OF THE PROJECT: _____

THE BANK ACCOUNT DETAILS ARE FURNISHED AS BELOW:

I/We _____ (Name of the Bidder) hereby request you to give our payments by crediting our bank account directly by E-Payment mode as per account details given below. We hereby undertake to intimate IWAI in case of any change in particulars given below and will not hold IWAI responsible for any delay / default due to any technical reasons beyond IWAI's control:-

Bank Account Number : _____

RTGS/NEFT/IFSC CODE : _____

Name of the Bank : _____

Address of the Branch of the Bank : _____

Branch code : _____

Account Type : _____
(Saving/Current/Others)

A BLANK CHEQUE (CANCELLED) IS ENCLOSED HEREWITH.

I/We hereby declare that the particulars given above are correct and complete. If the transaction is delayed or credit is not affected at all for reasons of incomplete or incorrect information, I/We would not hold IWAI responsible.

Date:

Signature of Authorized Signatory

BANK CERTIFICATION:

It is certified that above mentioned beneficiary holds a bank account No. _____ with our branch and the bank particulars mentioned above are correct.

Date:

Authorized Signatory

Authorization

No. _____

Name: _____

Official Seal/Stamp.

Fencing Drawing

RCC Pole-

Vertical dia of steel- 8mm @ 4 nos.
 Stirrups dia of steel- 8 mm
 Spacing of pillars- 3 mtr.

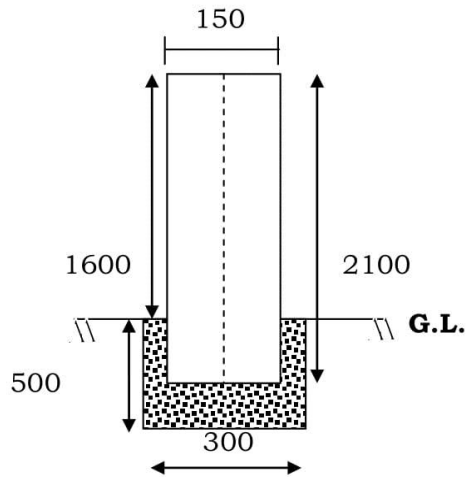

GI or MS Barbed Wire-

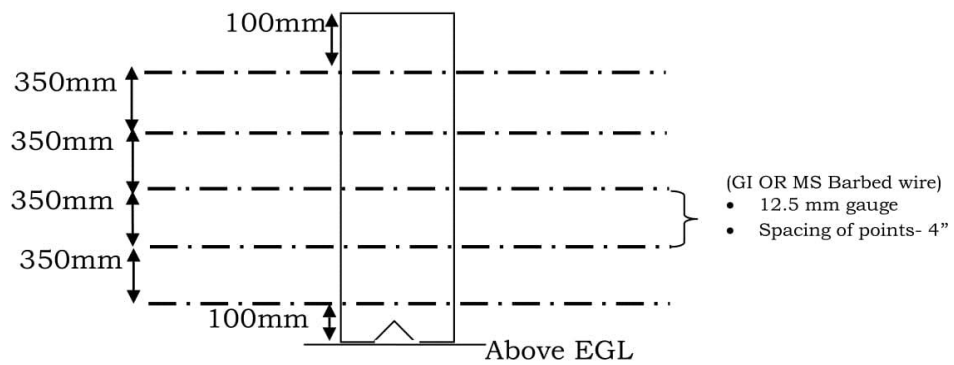

5 nos. barbed wire with 0.350mtr. Spacing
 Total = (10mtrX5nos.) = 50 rmt.

Note:- Drawing not to scale

Site Drawing

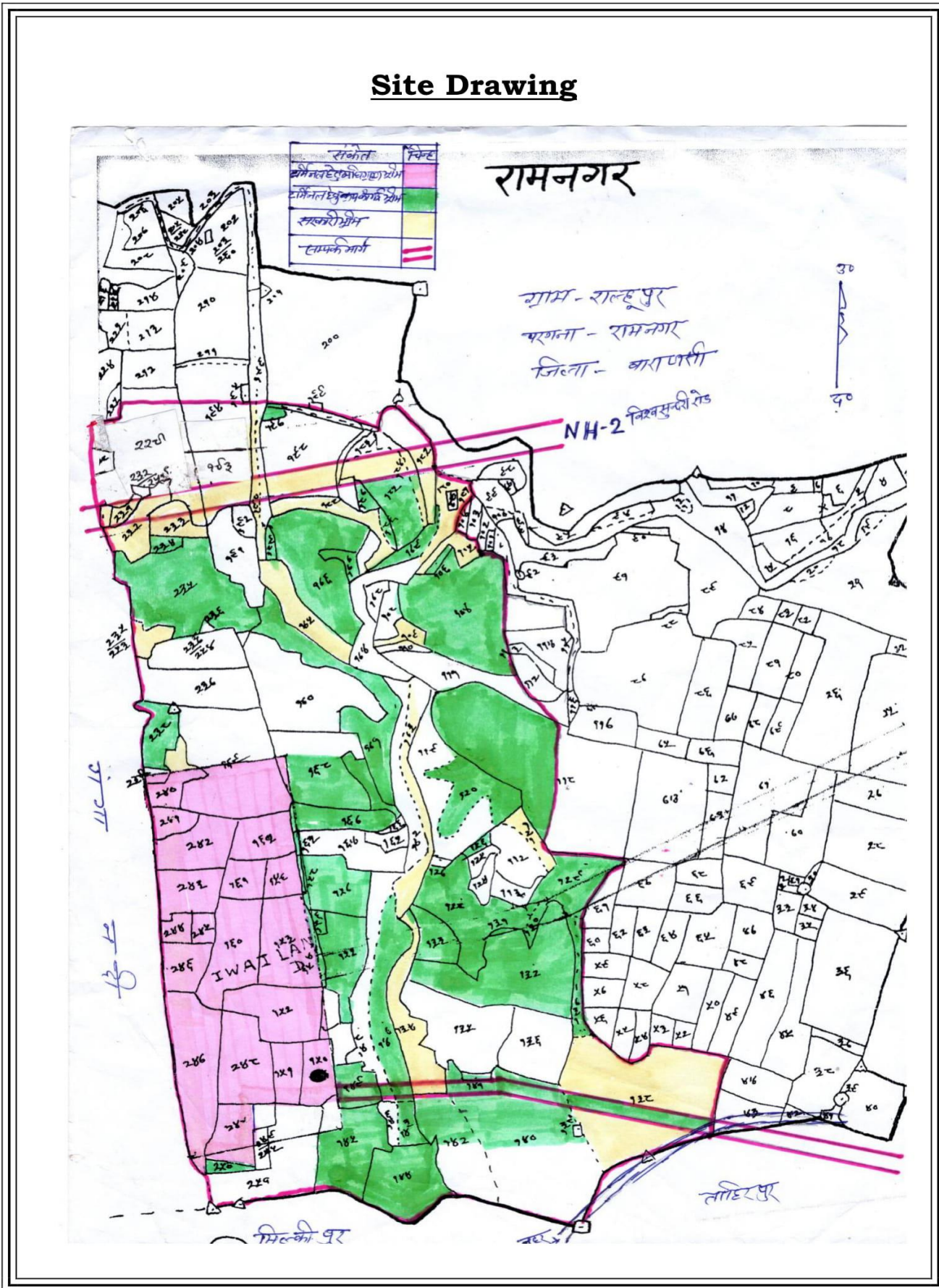

No. P-45021/2/2017-PP (BE-II)
Government of India
Ministry of Commerce and Industry
Department for Promotion of Industry and Internal Trade
(Public Procurement Section)

Udyog Bhawan, New Delhi
Dated: 04th June, 2020

To

All Central Ministries/Departments/CPSUs/All concerned

ORDER

Subject: Public Procurement (Preference to Make in India), Order 2017– Revision; regarding.

Department for Promotion of Industry and Internal Trade, in partial modification [Paras 2, 3, 5, 9(a), 9(b) and 10(b) modified and Para 3A added] of Order No.P-45021/2/2017-B.E.-II dated 15.6.2017 as amended by Order No.P-45021/2/2017-B.E.-II dated 28.05.2018 and Order No.P-45021/2/2017-B.E.-II dated 29.05.2019, hereby issues the revised 'Public Procurement (Preference to Make in India), Order 2017' dated 04.06.2020 effective with immediate effect.

Whereas it is the policy of the Government of India to encourage 'Make in India' and promote manufacturing and production of goods and services in India with a view to enhancing income and employment, and

Whereas procurement by the Government is substantial in amount and can contribute towards this policy objective, and

Whereas local content can be increased through partnerships, cooperation with local companies, establishing production units in India or Joint Ventures (JV) with Indian suppliers, increasing the participation of local employees in services and training them,

Now therefore the following Order is issued:

1. This Order is issued pursuant to Rule 153 (iii) of the General Financial Rules 2017.
2. **Definitions:** For the purposes of this Order:

'Local content' means the amount of value added in India which shall, unless otherwise prescribed by the Nodal Ministry, be the total value of the item procured (excluding net domestic indirect taxes) minus the value of imported content in the item (including all customs duties) as a proportion of the total value, in percent.

'Class-I local supplier' means a supplier or service provider, whose goods, services or works offered for procurement, has local content equal to or more than 50%, as defined under this Order.

'Class-II local supplier' means a supplier or service provider, whose goods, services or works offered for procurement, has local content more than 20% but less than 50%, as defined under this Order.

.....Contd. p/2

'Non - Local supplier' means a supplier or service provider, whose goods, services or works offered for procurement, has local content less than or equal to 20%, as defined under this Order.

'L1' means the lowest tender or lowest bid or the lowest quotation received in a tender, bidding process or other procurement solicitation as adjudged in the evaluation process as per the tender or other procurement solicitation.

'Margin of purchase preference' means the maximum extent to which the price quoted by a "Class-I local supplier" may be above the L1 for the purpose of purchase preference.

'Nodal Ministry' means the Ministry or Department identified pursuant to this order in respect of a particular item of goods or services or works.

'Procuring entity' means a Ministry or department or attached or subordinate office of, or autonomous body controlled by, the Government of India and includes Government companies as defined in the Companies Act.

'Works' means all works as per Rule 130 of GFR- 2017, and will also include *'turnkey works'*.

3. Eligibility of 'Class-I local supplier'/ 'Class-II local supplier'/ 'Non-local suppliers' for different types of procurement

(a) In procurement of all goods, services or works in respect of which the Nodal Ministry / Department has communicated that there is sufficient local capacity and local competition, only 'Class-I local supplier', as defined under the Order, shall be eligible to bid irrespective of purchase value.

(b) In procurement of all goods, services or works, not covered by sub-para 3(a) above, and with estimated value of purchases less than Rs. 200 Crore, in accordance with Rule 161(iv) of GFR, 2017, Global tender enquiry shall not be issued except with the approval of competent authority as designated by Department of Expenditure. Only 'Class-I local supplier' and 'Class-II local supplier', as defined under the Order, shall be eligible to bid in procurements undertaken by procuring entities, except when Global tender enquiry has been issued. In global tender enquiries, 'Non-local suppliers' shall also be eligible to bid along with 'Class-I local suppliers' and 'Class-II local suppliers'.

(c) For the purpose of this Order, works includes Engineering, Procurement and Construction (EPC) contracts and services include System Integrator (SI) contracts.

3A. Purchase Preference

(a) Subject to the provisions of this Order and to any specific instructions issued by the Nodal Ministry or in pursuance of this Order, purchase preference shall be given to 'Class-I local supplier' in procurements undertaken by procuring entities in the manner specified here under.

.....Contd. p/3

(b) In the procurements of goods or works, which are covered by para 3(b) above and which are divisible in nature, the 'Class-I local supplier' shall get purchase preference over 'Class-II local supplier' as well as 'Non-local supplier', as per following procedure:

- i. Among all qualified bids, the lowest bid will be termed as L1. If L1 is 'Class-I local supplier', the contract for full quantity will be awarded to L1.
- ii. If L1 bid is not a 'Class-I local supplier', 50% of the order quantity shall be awarded to L1. Thereafter, the lowest bidder among the 'Class-I local supplier' will be invited to match the L1 price for the remaining 50% quantity subject to the Class-I local supplier's quoted price falling within the margin of purchase preference, and contract for that quantity shall be awarded to such 'Class-I local supplier' subject to matching the L1 price. In case such lowest eligible 'Class-I local supplier' fails to match the L1 price or accepts less than the offered quantity, the next higher 'Class-I local supplier' within the margin of purchase preference shall be invited to match the L1 price for remaining quantity and so on, and contract shall be awarded accordingly. In case some quantity is still left uncovered on Class-I local suppliers, then such balance quantity may also be ordered on the L1 bidder.

(c) In the procurements of goods or works, which are covered by para 3(b) above and which are not divisible in nature, and in procurement of services where the bid is evaluated on price alone, the 'Class-I local supplier' shall get purchase preference over 'Class-II local supplier' as well as 'Non-local supplier', as per following procedure:

- i. Among all qualified bids, the lowest bid will be termed as L1. If L1 is 'Class-I local supplier', the contract will be awarded to L1.
- ii. If L1 is not 'Class-I local supplier', the lowest bidder among the 'Class-I local supplier', will be invited to match the L1 price subject to Class-I local supplier's quoted price falling within the margin of purchase preference, and the contract shall be awarded to such 'Class-I local supplier' subject to matching the L1 price.
- iii. In case such lowest eligible 'Class-I local supplier' fails to match the L1 price, the 'Class-I local supplier' with the next higher bid within the margin of purchase preference shall be invited to match the L1 price and so on and contract shall be awarded accordingly. In case none of the 'Class-I local supplier' within the margin of purchase preference matches the L1 price, the contract may be awarded to the L1 bidder.

(d) "Class-II local supplier" will not get purchase preference in any procurement, undertaken by procuring entities.

4. **Exemption of small purchases:** Notwithstanding anything contained in paragraph 3, procurements where the estimated value to be procured is less than Rs. 5 lakhs shall be exempt from this Order. However, it shall be ensured by procuring entities that procurement is not split for the purpose of avoiding the provisions of this Order.
5. **Minimum local content:** The local content requirement to categorize a supplier as 'Class-I local supplier'/ 'Class-II local supplier'/ 'Non-local supplier' shall be as defined in the Para "2" of the Order. No change is permissible on this account. However, if any nodal Ministry/ Department finds that for any particular item, pertaining to their nodal ministry/department, the definition of Local Content, as defined in the Order, is not workable/ has limitations, it may notify alternate suitable mechanism for calculation of local content for that particular item.
6. **Margin of Purchase Preference:** The margin of purchase preference shall be 20%.
7. **Requirement for specification in advance:** The minimum local content, the margin of purchase preference and the procedure for preference to Make in India shall be specified in the notice inviting tenders or other form of procurement solicitation and shall not be varied during a particular procurement transaction.
8. **Government E-marketplace:** In respect of procurement through the Government E-marketplace (GeM) shall, as far as possible, specifically mark the items which meet the minimum local content while registering the item for display, and shall, wherever feasible, make provision for automated comparison with purchase preference and without purchase preference and for obtaining consent of the local supplier in those cases where purchase preference is to be exercised.
9. **Verification of local content:**
 - a. The 'Class-I local supplier'/ 'Class-II local supplier' at the time of tender, bidding or solicitation shall be required to indicate percentage of local content and provide self-certification that the item offered meets the local content requirement for 'Class-I local supplier'/ 'Class-II local supplier', as the case may be. They shall also give details of the location(s) at which the local value addition is made.
 - b. In cases of procurement for a value in excess of Rs. 10 crores, the 'Class-I local supplier'/ 'Class-II local supplier' shall be required to provide a certificate from the statutory auditor or cost auditor of the company (in the case of companies) or from a practicing cost accountant or practicing chartered accountant (in respect of suppliers other than companies) giving the percentage of local content.
 - c. Decisions on complaints relating to implementation of this Order shall be taken by the competent authority which is empowered to look into procurement-related complaints relating to the procuring entity.

.....Contd. p/5

- d. Nodal Ministries may constitute committees with internal and external experts for independent verification of self-declarations and auditor's/ accountant's certificates on random basis and in the case of complaints.
- e. Nodal Ministries and procuring entities may prescribe fees for such complaints.
- f. False declarations will be in breach of the Code of Integrity under Rule 175(1)(i)(h) of the General Financial Rules for which a bidder or its successors can be debarred for up to two years as per Rule 151 (iii) of the General Financial Rules along with such other actions as may be permissible under law.
- g. A supplier who has been debarred by any procuring entity for violation of this Order shall not be eligible for preference under this Order for procurement by any other procuring entity for the duration of the debarment. The debarment for such other procuring entities shall take effect prospectively from the date on which it comes to the notice of other procurement entities, in the manner prescribed under paragraph 9h below.
- h. The Department of Expenditure shall issue suitable instructions for the effective and smooth operation of this process, so that:
 - i. The fact and duration of debarment for violation of this Order by any procuring entity are promptly brought to the notice of the Member-Convenor of the Standing Committee and the Department of Expenditure through the concerned Ministry /Department or in some other manner;
 - ii. on a periodical basis such cases are consolidated and a centralized list or decentralized lists of such suppliers with the period of debarment is maintained and displayed on website(s);
 - iii. in respect of procuring entities other than the one which has carried out the debarment, the debarment takes effect prospectively from the date of uploading on the website(s) in the such a manner that ongoing procurements are not disrupted.

10. Specifications in Tenders and other procurement solicitations:

- a. Every procuring entity shall ensure that the eligibility conditions in respect of previous experience fixed in any tender or solicitation do not require proof of supply in other countries or proof of exports.
- b. Procuring entities shall endeavour to see that eligibility conditions, including on matters like turnover, production capability and financial strength do not result in unreasonable exclusion of 'Class-I local supplier'/ 'Class-II local supplier' who would otherwise be eligible, beyond what is essential for ensuring quality or creditworthiness of the supplier.
- c. Procuring entities shall, within 2 months of the issue of this Order review all existing eligibility norms and conditions with reference to sub-paragraphs 'a' and 'b' above.

.....Contd. p/6

- d. If a Nodal Ministry is satisfied that Indian suppliers of an item are not allowed to participate and/ or compete in procurement by any foreign government, it may, if it deems appropriate, restrict or exclude bidders from that country from eligibility for procurement of that item and/ or other items relating to that Nodal Ministry. A copy of every instruction or decision taken in this regard shall be sent to the Chairman of the Standing Committee.
- e. For the purpose of sub-paragraph 10 d above, a supplier or bidder shall be considered to be from a country if (i) the entity is incorporated in that country, or ii) a majority of its shareholding or effective control of the entity is exercised from that country; or (iii) more than 50% of the value of the item being supplied has been added in that country. Indian suppliers shall mean those entities which meet any of these tests with respect to India."

10A. Action for non-compliance of the Provisions of the Order: In case restrictive or discriminatory conditions against domestic suppliers are included in bid documents, an inquiry shall be conducted by the Administrative Department undertaking the procurement (including procurement by any entity under its administrative control) to fix responsibility for the same. Thereafter, appropriate action, administrative or otherwise, shall be taken against erring officials of procurement entities under relevant provisions. Intimation on all such actions shall be sent to the Standing Committee.

11. Assessment of supply base by Nodal Ministries: The Nodal Ministry shall keep in view the domestic manufacturing / supply base and assess the available capacity and the extent of local competition while identifying items and prescribing minimum local content or the manner of its calculation, with a view to avoiding cost increase from the operation of this Order.

12. Increase in minimum local content: The Nodal Ministry may annually review the local content requirements with a view to increasing them, subject to availability of sufficient local competition with adequate quality.

13. Manufacture under license/ technology collaboration agreements with phased indigenization: While notifying the minimum local content, Nodal Ministries may make special provisions for exempting suppliers from meeting the stipulated local content if the product is being manufactured in India under a license from a foreign manufacturer who holds intellectual property rights and where there is a technology collaboration agreement / transfer of technology agreement for indigenous manufacture of a product developed abroad with clear phasing of increase in local content.

14. Powers to grant exemption and to reduce minimum local content: The administrative Department undertaking the procurement (including procurement by any entity under its administrative control), with the approval of their Minister-in-charge, may by written order, for reasons to be recorded in writing,

- a. reduce the minimum local content below the prescribed level; or
- b. reduce the margin of purchase preference below 20%; or

.....Contd. p/7

- c. exempt any particular item or supplying entities from the operation of this Order or any part of the Order.

A copy of every such order shall be provided to the Standing Committee and concerned Nodal Ministry / Department. The Nodal Ministry / Department concerned will continue to have the power to vary its notification on Minimum Local Content.

15. **Directions to Government companies:** In respect of Government companies and other procuring entities not governed by the General Financial Rules, the administrative Ministry or Department shall issue policy directions requiring compliance with this Order.

16. **Standing Committee:** A standing committee is hereby constituted with the following membership:

Secretary, Department for Promotion of Industry and Internal Trade—Chairman
Secretary, Commerce—Member
Secretary, Ministry of Electronics and Information Technology—Member
Joint Secretary (Public Procurement), Department of Expenditure—Member
Joint Secretary (DPIIT)—Member-Convenor

The Secretary of the Department concerned with a particular item shall be a member in respect of issues relating to such item. The Chairman of the Committee may co-opt technical experts as relevant to any issue or class of issues under its consideration.

17. **Functions of the Standing Committee:** The Standing Committee shall meet as often as necessary, but not less than once in six months. The Committee
 - a. shall oversee the implementation of this order and issues arising therefrom, and make recommendations to Nodal Ministries and procuring entities.
 - b. shall annually assess and periodically monitor compliance with this Order
 - c. shall identify Nodal Ministries and the allocation of items among them for issue of notifications on minimum local content
 - d. may require furnishing of details or returns regarding compliance with this Order and related matters
 - e. may, during the annual review or otherwise, assess issues, if any, where it is felt that the manner of implementation of the order results in any restrictive practices, cartelization or increase in public expenditure and suggest remedial measures
 - f. may examine cases covered by paragraph 13 above relating to manufacture under license/ technology transfer agreements with a view to satisfying itself that adequate mechanisms exist for enforcement of such agreements and for attaining the underlying objective of progressive indigenization
 - g. may consider any other issue relating to this Order which may arise.

18. **Removal of difficulties:** Ministries /Departments and the Boards of Directors of Government companies may issue such clarifications and instructions as may be necessary for the removal of any difficulties arising in the implementation of this Order.

.....Contd. p/8

19. **Ministries having existing policies:** Where any Ministry or Department has its own policy for preference to local content approved by the Cabinet after 1st January 2015, such policies will prevail over the provisions of this Order. All other existing orders on preference to local content shall be reviewed by the Nodal Ministries and revised as needed to conform to this Order, within two months of the issue of this Order.
20. **Transitional provision:** This Order shall not apply to any tender or procurement for which notice inviting tender or other form of procurement solicitation has been issued before the issue of this Order.

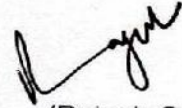

(Rajesh Gupta)
Director

Tel: 23063211

rajesh.gupta66@gov.in